

Switching Transistors

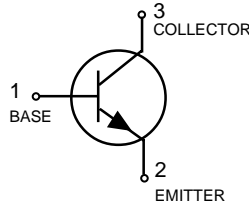

LMBT2369LT1
LMBT2369ALT1

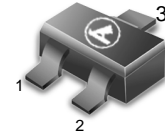

SC-70/SOT-323

MAXIMUM RATINGS

Rating	Symbol	Value	Unit
Collector–Emitter Voltage	V_{CEO}	15	Vdc
Collector–Emitter Voltage	V_{CES}	40	Vdc
Collector–Base Voltage	V_{CBO}	40	Vdc
Emitter–Base Voltage	V_{EBO}	4.5	Vdc
Collector Current — Continuous	I_C	200	mAdc

THERMAL CHARACTERISTICS

Characteristic	Symbol	Max	Unit
Total Device Dissipation FR– 5 Board, (1) $T_A = 25^\circ\text{C}$	P_D	225	mW
Derate above 25°C		1.8	mW/ $^\circ\text{C}$
Thermal Resistance, Junction to Ambient	$R_{\theta JA}$	556	$^\circ\text{C}/\text{W}$
Total Device Dissipation Alumina Substrate, (2) $T_A = 25^\circ\text{C}$	P_D	300	mW
Derate above 25°C		2.4	mW/ $^\circ\text{C}$
Thermal Resistance, Junction to Ambient	$R_{\theta JA}$	417	$^\circ\text{C}/\text{W}$
Junction and Storage Temperature	T_J, T_{stg}	–55 to +150	$^\circ\text{C}$

DEVICE MARKING

LMBT2369LT1 = M1J, LMBT2369ALT1 = 1JA

ELECTRICAL CHARACTERISTICS ($T_A = 25^\circ\text{C}$ unless otherwise noted.)

Characteristic	Symbol	Min	Typ	Max	Unit
----------------	--------	-----	-----	-----	------

OFF CHARACTERISTICS

Collector–Emitter Breakdown Voltage(3) ($I_C = 10 \text{ mAdc}, I_B = 0$)	$V_{(BR)CEO}$	15	—	—	Vdc
Collector–Emitter Breakdown Voltage ($I_C = 10 \text{ }\mu\text{Adc}, V_{BE} = 0$)	$V_{(BR)CES}$	40	—	—	Vdc
Collector–Base Breakdown Voltage ($I_C = 10 \text{ }\mu\text{Adc}, I_E = 0$)	$V_{(BR)CBO}$	40	—	—	Vdc
Emitter–Base Breakdown Voltage ($I_E = 10 \text{ }\mu\text{Adc}, I_C = 0$)	$V_{(BR)EBO}$	4.5	—	—	Vdc
Collector Cutoff Current($V_{CB} = 20\text{Vdc}, I_E = 0$) ($V_{CB} = 20\text{Vdc}, I_E = 0, T_A = 150^\circ\text{C}$)	I_{CBO}	—	—	0.4 30	μAdc
Collector Cutoff Current ($V_{CE} = 20\text{Vdc}, V_{BE} = 0$)	I_{CES}	—	—	0.4	μAdc

1. FR–5 = 1.0 x 0.75 x 0.062 in.

2. Alumina = 0.4 x 0.3 x 0.024 in. 99.5% alumina.

3. Pulse Test: Pulse Width $\leq 300 \text{ }\mu\text{s}$, Duty Cycle $\leq 2.0\%$.

LMBT2369LT1 LMBT2369ALT1

ELECTRICAL CHARACTERISTICS ($T_A = 25^\circ\text{C}$ unless otherwise noted) (Continued)

Characteristic	Symbol	Min	Typ	Max	Unit
----------------	--------	-----	-----	-----	------

ON CHARACTERISTICS

DC Current Gain(3)	h_{FE}				—
($I_C = 10\text{ mAdc}$, $V_{CE} = 1.0\text{ Vdc}$)	LMBT2369	40	—	120	
($I_C = 10\text{ mAdc}$, $V_{CE} = 1.0\text{ Vdc}$)	LMBT2369A	—	—	120	
($I_C = 10\text{ mAdc}$, $V_{CE} = 0.35\text{ Vdc}$)	LMBT2369A	40	—	—	
($I_C = 10\text{ mAdc}$, $V_{CE} = 0.35\text{ Vdc}$, $T_A = -55^\circ\text{C}$)	LMBT2369A	20	—	—	
($I_C = 30\text{ mAdc}$, $V_{CE} = 0.4\text{ Vdc}$)	LMBT2369A	30	—	—	
($I_C = 100\text{ mAdc}$, $V_{CE} = 2.0\text{ Vdc}$)	LMBT2369	20	—	—	
($I_C = 100\text{ mAdc}$, $V_{CE} = 1.0\text{ Vdc}$)	LMBT2369A	20	—	—	
Collector–Emitter Saturation Voltage(3)	$V_{CE(sat)}$				Vdc
($I_C = 10\text{ mAdc}$, $I_B = 1.0\text{ mAdc}$)	LMBT2369	—	—	0.25	
($I_C = 10\text{ mAdc}$, $I_B = 1.0\text{ mAdc}$)	LMBT2369A	—	—	0.20	
($I_C = 10\text{ mAdc}$, $I_B = 1.0\text{ mAdc}$, $T_A = +125^\circ\text{C}$)	LMBT2369A	—	—	0.30	
($I_C = 30\text{ mAdc}$, $I_B = 3.0\text{ mAdc}$)	LMBT2369A	—	—	0.25	
($I_C = 100\text{ mAdc}$, $I_B = 10\text{ mAdc}$)	LMBT2369A	—	—	0.50	
Base–Emitter Saturation Voltage	$V_{BE(sat)}$				Vdc
($I_C = 10\text{ mAdc}$, $I_B = 1.0\text{ mAdc}$)	LMBT2369A	0.7	—	0.85	
($I_C = 10\text{ mAdc}$, $I_B = 1.0\text{ mAdc}$, $T_A = -55^\circ\text{C}$)	LMBT2369A	—	—	1.02	
($I_C = 30\text{ mAdc}$, $I_B = 3.0\text{ mAdc}$)	LMBT2369A	—	—	1.15	
($I_C = 100\text{ mAdc}$, $I_B = 10\text{ mAdc}$)	LMBT2369A	—	—	1.60	

SMALL–SIGNAL CHARACTERISTICS

Output Capacitance ($V_{CB} = 5.0\text{ Vdc}$, $I_E = 0$, $f = 1.0\text{ MHz}$)	C_{obo}	—	—	4.0	pF
Small–Signal Current Gain ($V_{CE} = 10\text{ Vdc}$, $I_C = 10\text{ mAdc}$, $f = 100\text{ MHz}$)	h_{fe}	5.0	—	—	—

SWITCHING CHARACTERISTICS

Storage Time ($I_{B1} = I_{B2} = I_C = 10\text{ mAdc}$)	t_s	—	5.0	13	ns
Turn–On Time ($V_{CC} = 3.0\text{ Vdc}$, $I_C = 10\text{ mAdc}$, $I_{B1} = 3.0\text{ mAdc}$)	t_{on}	—	8.0	12	ns
Turn–Off Time ($V_{CC} = 3.0\text{ Vdc}$, $I_C = 10\text{ mAdc}$, $I_{B1} = 3.0\text{ mAdc}$, $I_{B2} = 1.5\text{ mAdc}$)	t_{off}	—	10	18	ns

3. Pulse Test: Pulse Width $\leq 300\text{ ms}$, Duty Cycle $\leq 2.0\%$.

LMBT2369LT1 LMBT2369ALT1

SWITCHING TIME EQUIVALENT TEST CIRCUITS FOR 2N2369, 2N3227

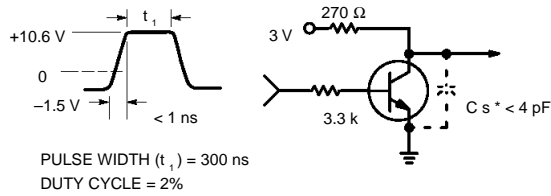

Figure 1. t_{on} Circuit — 10 mA

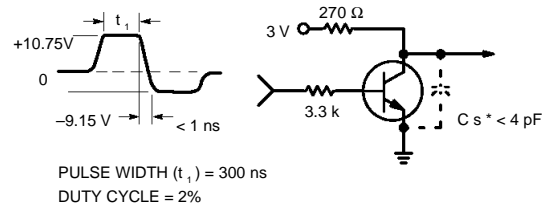

Figure 3. t_{off} Circuit — 10 mA

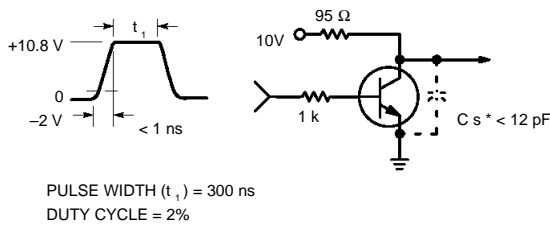

Figure 2. t_{on} Circuit — 100 mA

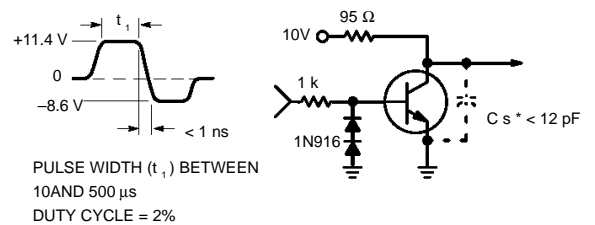

Figure 4. t_{off} Circuit — 100 mA

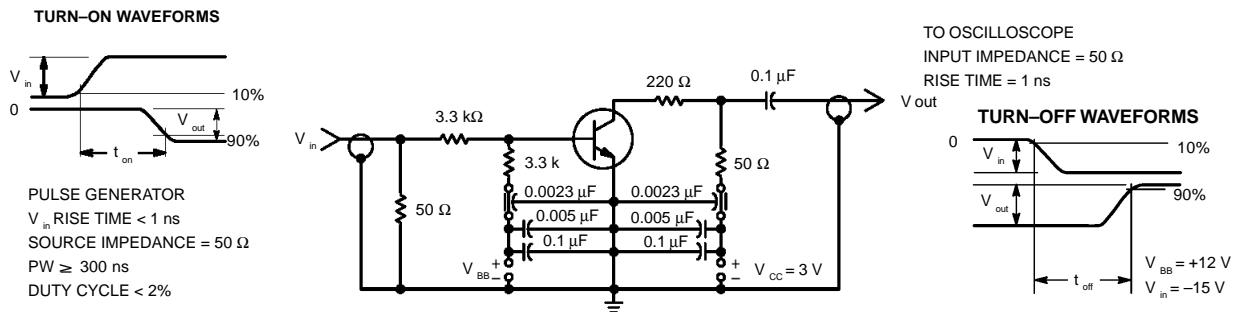

Figure 5. Turn-On and Turn-Off Time Test Circuit

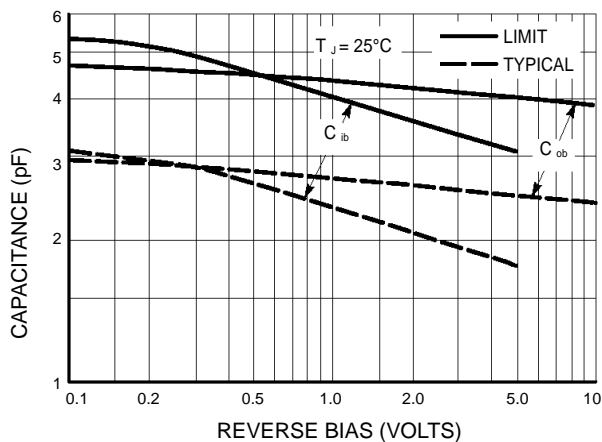

Figure 6. Junction Capacitance Variations

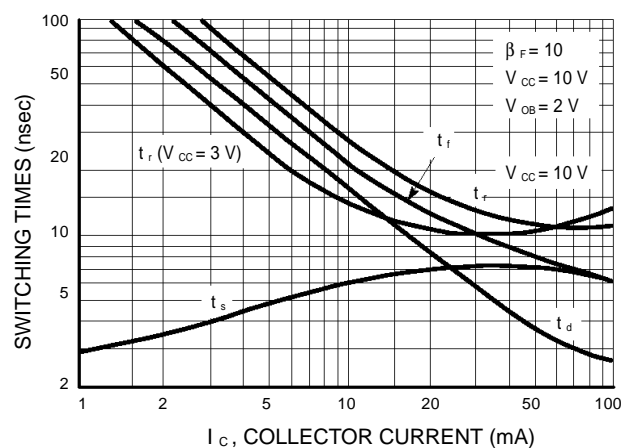

Figure 7. Typical Switching Times

LMBT2369LT1 LMBT2369ALT1

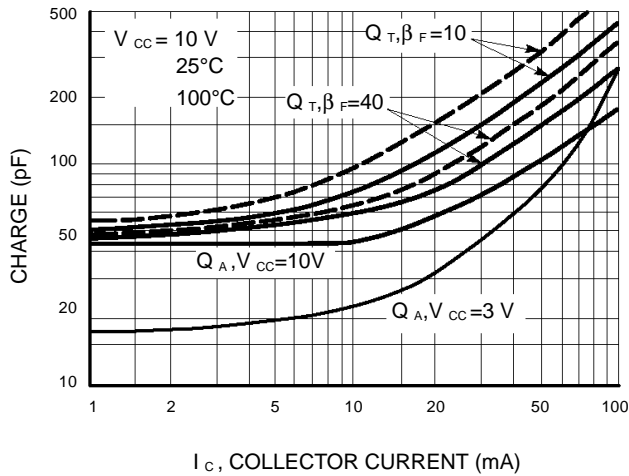

Figure 8. Maximum Charge Data

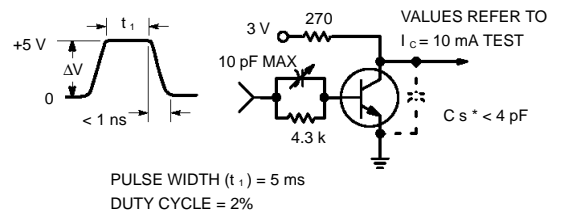

Figure 9. Q T Test Circuit

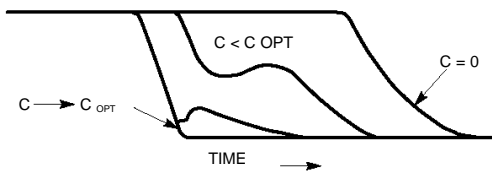

Figure 10. Turn-Off Waveform

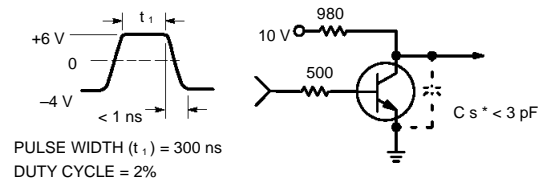

Figure 11. Storage Time Equivalent Test Circuit

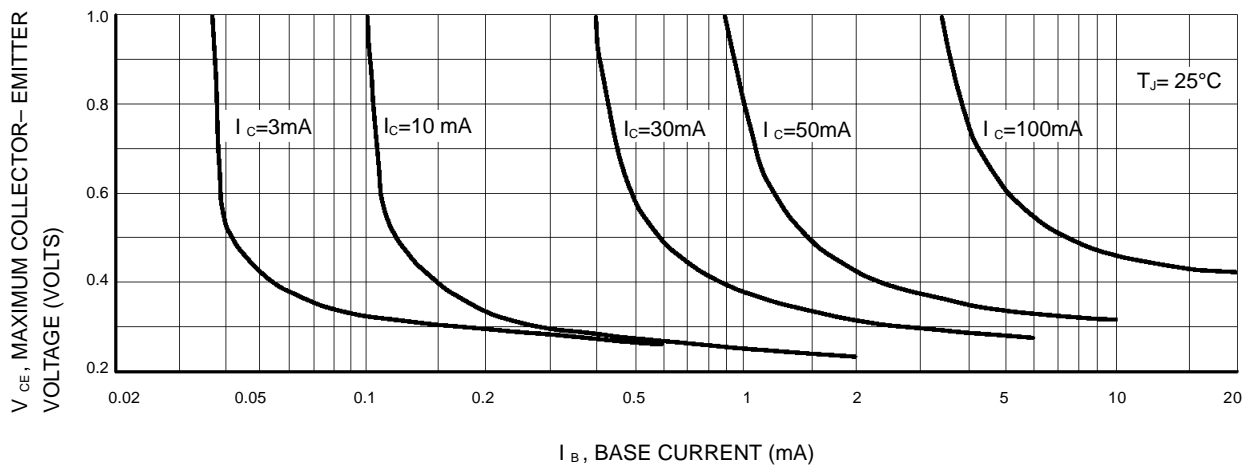

Figure 12. Maximum Collector Saturation Voltage Characteristics

LMBT2369LT1 LMBT2369ALT1

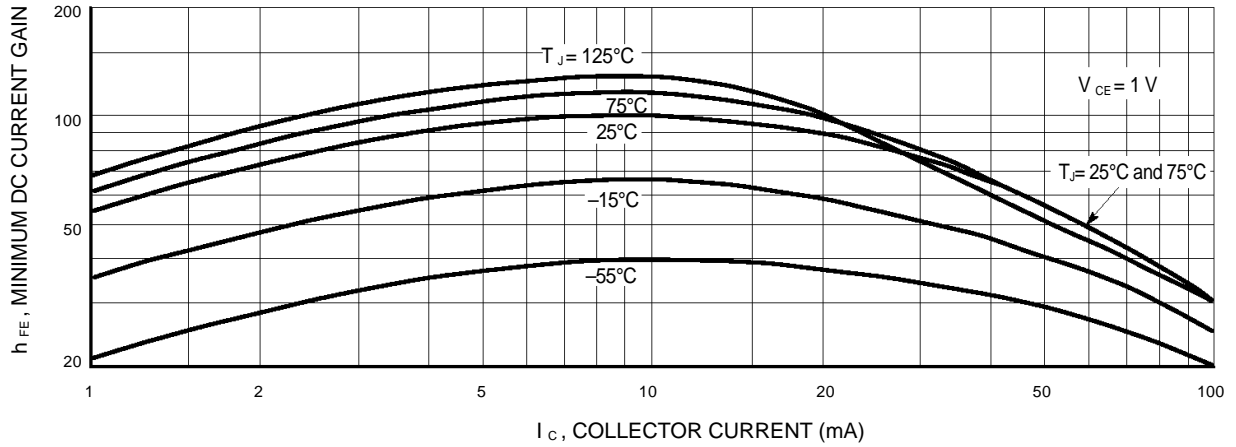

Figure 13. Minimum Current Gain Characteristics

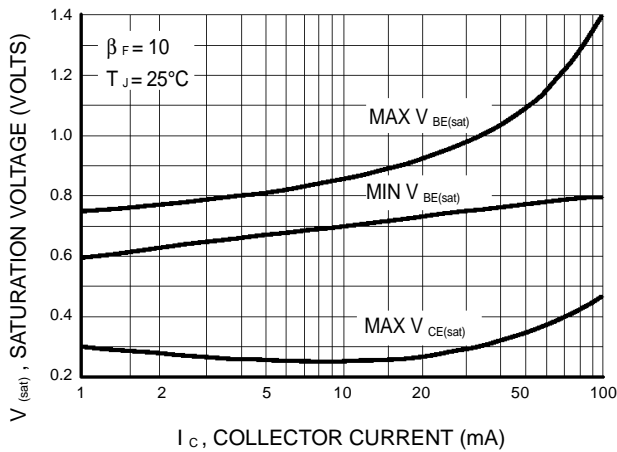

Figure 14. Saturation Voltage Limits

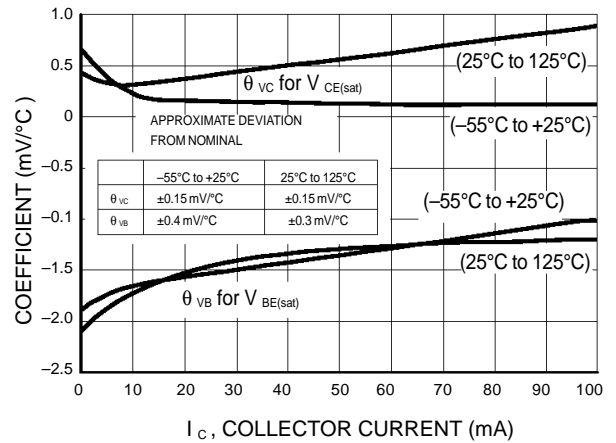

Figure 15. Typical Temperature Coefficients



LMBT2369LT1 LMBT2369ALT1

SC-70 / SOT-323

NOTES:

1. DIMENSIONING AND TOLERANCING PER ANSI Y14.5M, 1982.
2. CONTROLLING DIMENSION: INCH.

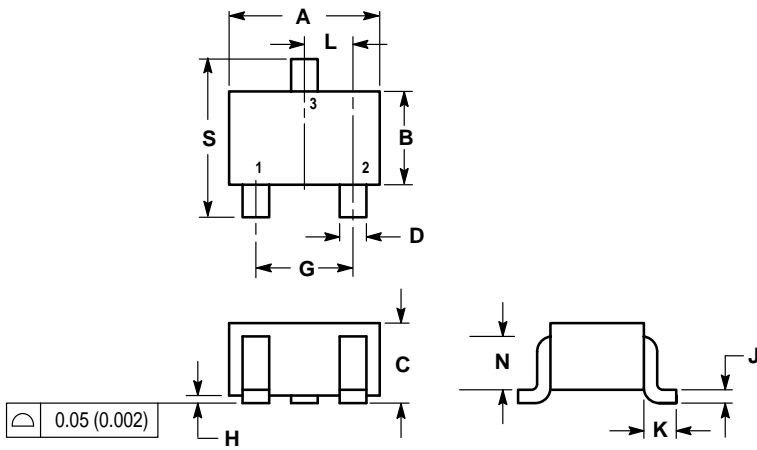

DIM	INCHES		MILLIMETERS	
	MIN	MAX	MIN	MAX
A	0.071	0.087	1.80	2.20
B	0.045	0.053	1.15	1.35
C	0.032	0.040	0.80	1.00
D	0.012	0.016	0.30	0.40
G	0.047	0.055	1.20	1.40
H	0.000	0.004	0.00	0.10
J	0.004	0.010	0.10	0.25
K	0.017 REF		0.425 REF	
L	0.026 BSC		0.650 BSC	
N	0.028 REF		0.700 REF	
S	0.079	0.095	2.00	2.40

- PIN 1. BASE
 2. EMITTER
 3. COLLECTOR

