

634 529
530

3M

查询"20468-0000-11"供应商

CompactFlash™ Interconnects



3M Committed to CompactFlash™ Technology

查询"20468-0000-11"供应商
In October, 1999, the CompactFlash Association (CFA) was established to standardize and promote CompactFlash™ technology as an open industry standard. The idea is to eliminate future compatibility issues between different hosts and different vendors. CF technology is essentially a PCMCIA card adapted to a smaller form factor. Because CF complies with the PCMCIA-ATA electrical interface standards, various flash suppliers can provide CF compatible products, independent of differences in the underlying flash memory technology employed by the various suppliers. CFA provides a framework for 3M to contribute advance interconnect technology in a worldwide market. As a member of CFA, you can rely on 3M for CompactFlash™ card compatibility.



3M Is Your Connection To CompactFlash™, The World's Smallest Removable Storage System.

If you are designing-in data storage for your next generation, hand-held portable device, be sure to spec 3M's interconnect components. 3M manufactures a full line of components and accessories for the CompactFlash™ card; you can get headers, ejectors, and adapters—the total interconnect solution—from a single source. 3M's interconnect components meet PCMCIA, JEIDA PC card standards, and CF specifications.

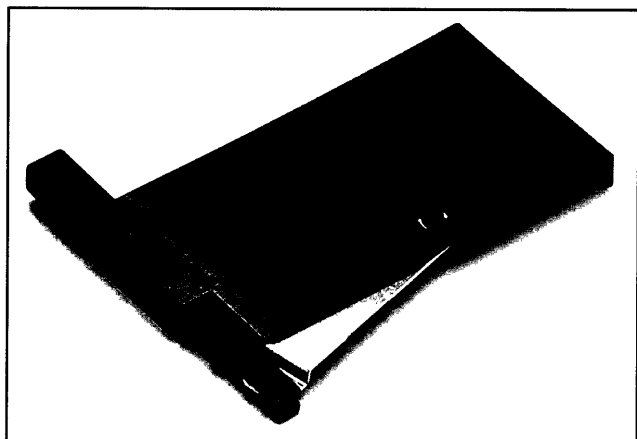

3M™ Ejector for CompactFlash™ Card

The 3M Ejector provides easy removal of the CF card from the right angle header.

- Shroud easily attaches to header after soldering
- Light and compact ejector mechanism
- Simple mechanism for reliable operation

Technical Data

3M Part Number D7E50-7316-02
Specification Sheet Number TS-0662-04

Components	Material
Shroud	Liquid Crystal Polyester (LCP) UL 94V-0, Black
Push Button	Glass Reinforced Polyester (PBT) UL 94V-0, Black
Lever Plate	Stainless Steel

Environmental Specifications

Item	Rating
Operating Temperature	-55°C to 85°C under 95% (non-condensing) RH
Storage Temperature	-40°C to 70°C under 95% (non-condensing) RH



3M™ Ejector for CompactFlash™ Card

查询"20468-0000-11"供应商

Right Button Ejector 3M Part D7E50-7316-02
(Order Separately)

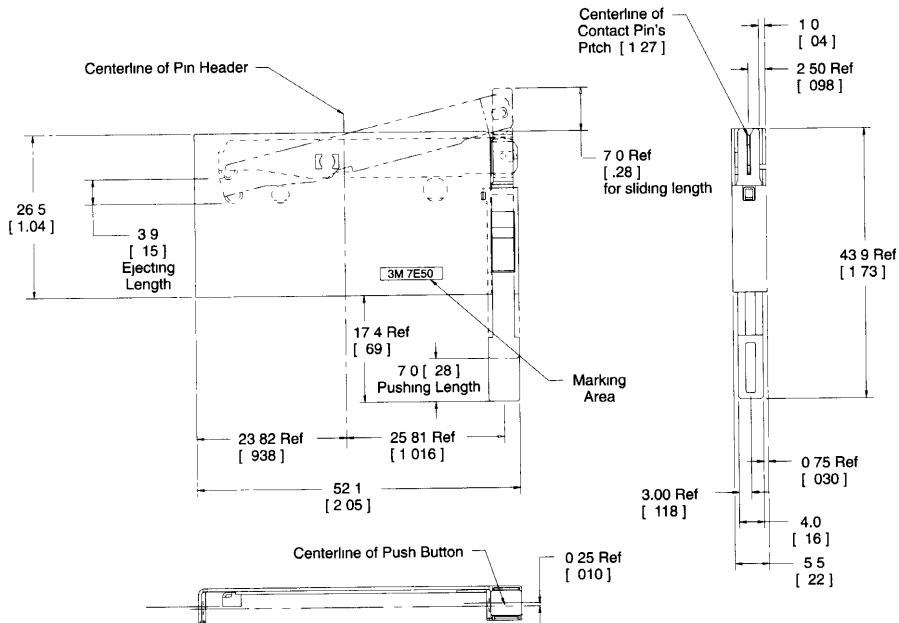

TS-0662-04

3M™ CompactFlash™ to PC Card Adapter

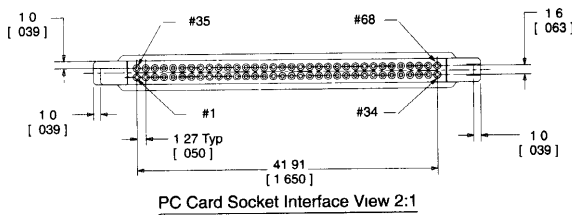

PC Card Socket Interface View 2:1

Pin Number	Pin Length ± .010
25, 26	3.50 [.137]
All other pins	4.25 [.167]
1, 13, 38, 50	5.00 [.196]

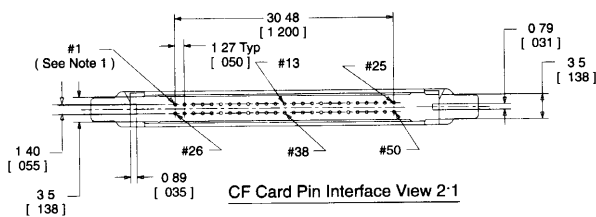
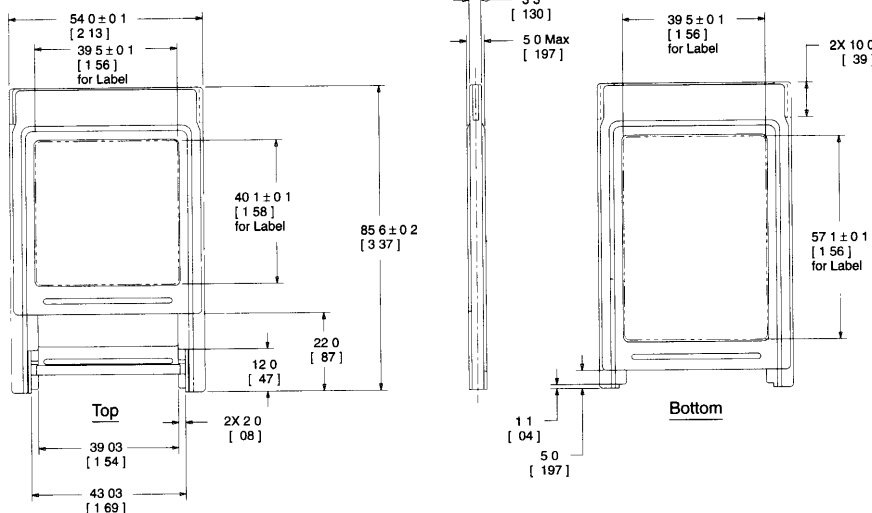

CF Card Pin Interface View 2:1

Note 1 See table for pin lengths of 50 position header

mm [inch]		
Tolerance Unless Noted		
	.0	.00 .000
mm	±.3	±.13

[] Dimensions for Reference only

3M™ Surface Mount CF Card Header

.050 x .050 ; 50-Position

查询"20468-0000-11"供应商

3M Part N7E50-7516VY-20

Pin Type	Interface Dim A	Pin No.
detect	3.50 [.137]	25, 26
general	4.25 [.167]	all other pins
power	5.00 [.196]	1, 13, 38 & 50

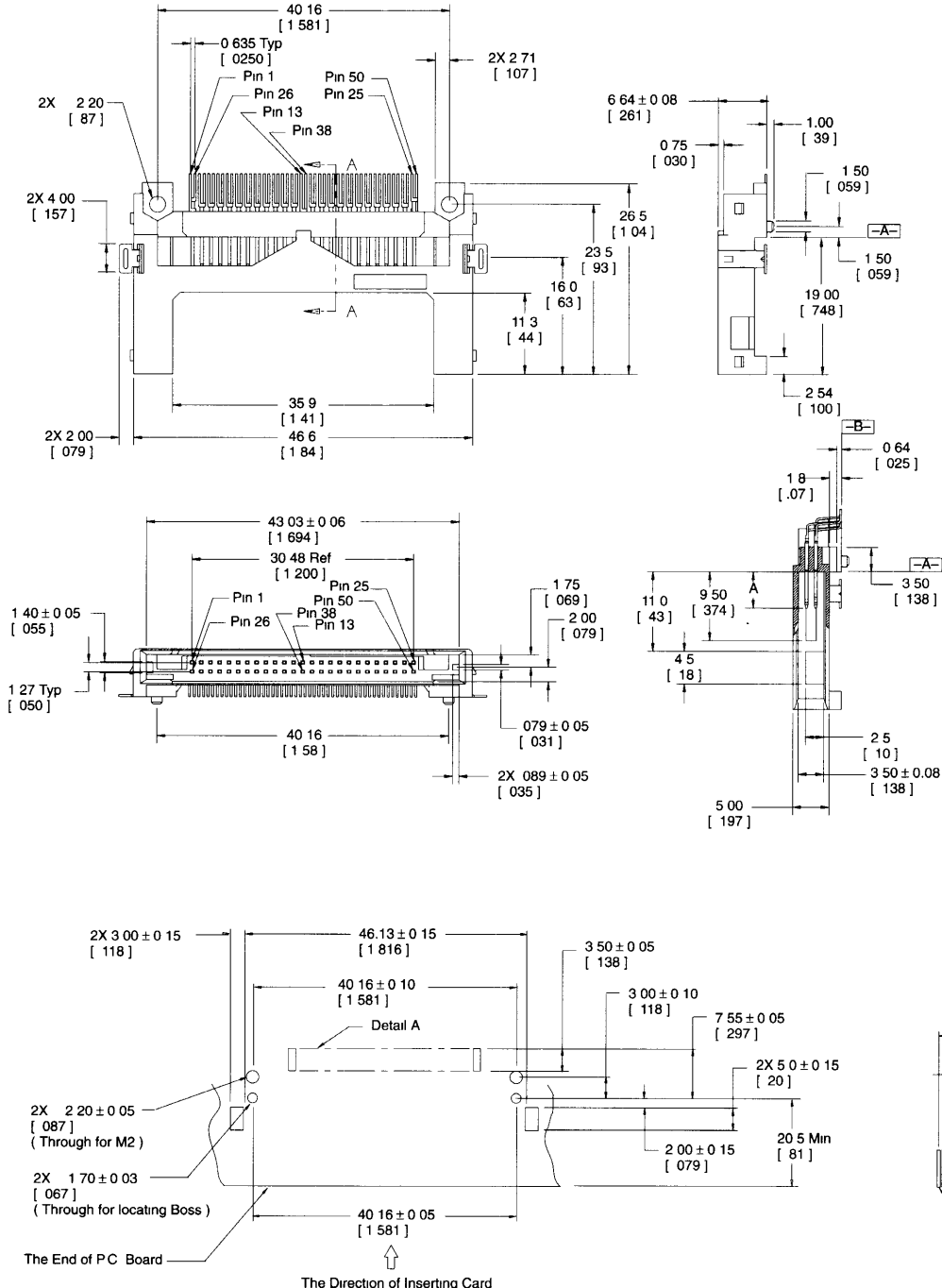

Recommended PCB Solder Pad Pattern

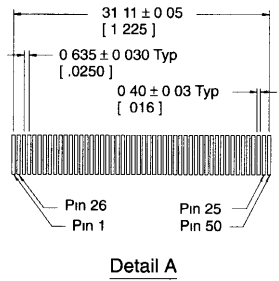

Section A-A

mm
[Inch]

Tolerance Unless Noted		
	.0	.00
	.00	.000
mm	±.3	±.13

[] Dimensions for Reference only

TS-0662-04

[查询"20468-0000-11"供应商](#)

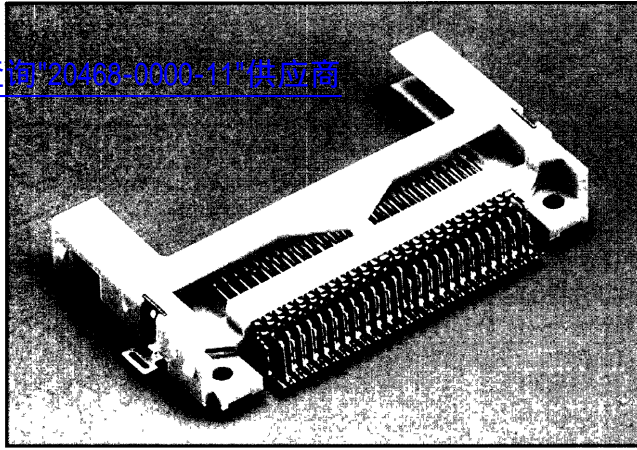

3M™ Surface Mount CF Card Header

The 3M 50-position right angle surface mount header interfaces to the 50-position CF socket in the CompactFlash™ card.

- Low profile design - 6.64 mm height
- Single row solder tails - 0.635 mm spacing
- Board component clearance - 1.64 mm standoff
- Screw-on mounting in addition to SMT solder tabs - provides added stability
- Optional ejector - to assist in card removal

Technical Data

3M Part Number
Specification Sheet Number

N7E50-7516VY-20
TS-0662-04

Components	Material
Body	Liquid Crystal Polyester (LCP) UL 94 V-0, Beige
Contact	Copper Alloy
Contact Plating	Underplate: Nickel Wiping Area: Gold over Palladium Nickel Solder Tails: Tin Lead
Solder Tab	Copper Alloy
Solder Tab Plating	Tin

Electrical Specifications

Item	Rating
Current Rating	0.5 A
Insulation Resistance	>1x 109Ω at 500 Vdc
Withstanding Voltage	500 Vrms at Sea Level

Environmental Specifications

Item	Rating
Operating Temperature	-55°C to 85°C
Processing Temperature	Maximum 235°C, with 90 seconds over 215°C

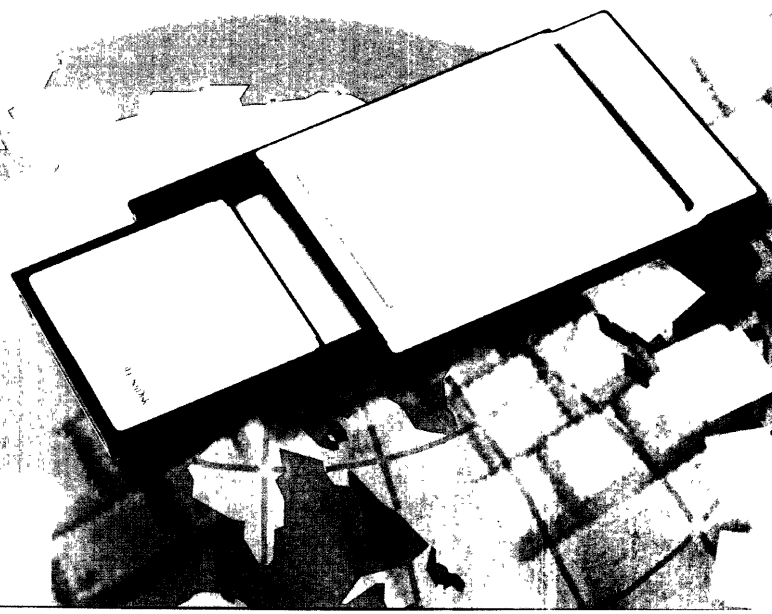
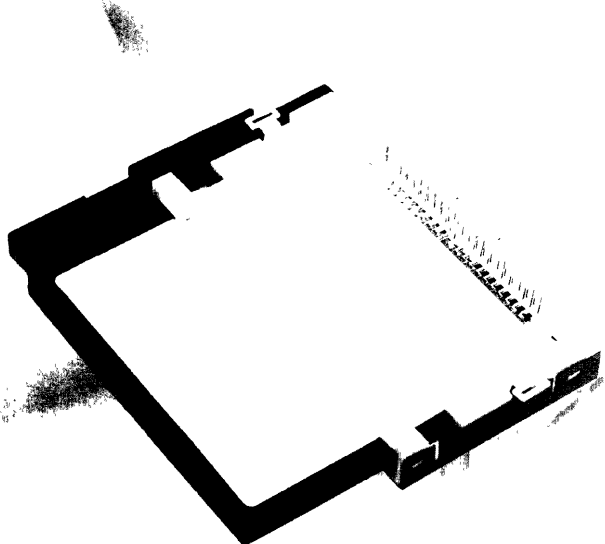

[查询"20468-0000-11"供应商](#)



3M™ CF Adapter for the Compact Flash™ Card

The 3M CF Adapter contains a 68-position PC Card socket (3M Part Number 9M68-1003TB) at one end, and a 50-position straddlemount CF header (3M Part Number 964716-01-25-30) at the other end.

The miniature memory storage card contains a 50-position CF memory card socket (3M Part Number 9M50-1091TB) which interfaces with the 50-position straddlemount CF header in the 3M CF Adapter.

Important Notice

Technical information provided by 3M is based on experience and/or tests believed to be reliable but their accuracy is not guaranteed and the results may not be relevant to every user's application

For this reason 3M does not accept responsibility or liability, direct or consequential, arising from reliance upon any information provided and the user should determine the suitability of the products for their intended use. Nothing in this statement will be deemed to exclude or restrict 3M's liability for death or personal injury arising from its negligence

3M

Electronics & Insulation Group

3M United Kingdom PLC
3M House, P.O. Box 1
Market Place, Bracknell
Berkshire RG12 1JU
Tel: +44 1344 858000
Fax: +44 1344 858278

3M Ireland
3M House, Adelphi Centre
Upper Georges Street
Dun Laoghaire, Co. Dublin
Tel: +353 1 2803555
Fax: +353 1 2803509

3M Belgium N.V.S.A.
Hermeslaan 7
B-1831 Diegem
Belgium
Tel: +32 2 722 5276
Fax: +32 2 722 5012

3M Netherland B.V.
P.O. Box 193
2300 AD Leiden
The Netherlands
Tel: +31 71 545 0364
Fax: +31 71 545 0378

3M France
Boulevard de l'Oise
95006 Cergy Pontoise Cedex
France
Tél: 33 01 3031 6161
Fax: 33 01 3031 7426

3M Deutschland GmbH
Carl-Schurz-Straße 1
Postfach 10 04 22
41453 Neuss
Tel: 49 2131 14-3165
Fax: 49 2131 14-2658

3M Italia S.p.A.
Via San Bovio 3
20090 Loc S.Felice
- Segrate (MI)
Tel: 39 2 70351
Fax: 39 2 7035 3090

3M Oesterreich Ges.m.b.H.
Brunner Feldstrasse 63
DVR: 000 3433/HRB 31.121
2380 Perchtoldsdorf
Direktwahl: 01/86 66 256
Telefax: 01/86 66 229

3M A/S
Fabriksparken 15
DK-2600 Glostrup
Denmark
Tel: +45 43 48 01 00
Fax: +45 43 96 85 96

Suomen 3M Oy
PL26 Sinimäentie 6
02630 Espoo
Finland
Tel: +358 0 52521
Fax: +358 0 520 664

3M Norge A/S
Hvamveien 6
Postboks 100 N-2013
Skjetten
Norway
Tel: +47 63 84 75 00
Fax: +47 63 84 17 88

3M Svenska AB
Bollstanäsvägen 3
S191 89 Sollentuna
Sweden
Tel: +46 8 92 2100
Fax: +46 8 754 553

3M (Schweiz) AG
Elektrostatik und
elektrotechnische
Spezialprodukte
Eggstrasse 93,
8803 Rüslikon
Direktwahl: 01/724 93 61
Telefax: 01/724 93 36

3M España S.A.
Calle Juan Ignaci
Luca de Tena 19-25
28027 Madrid, Spain
Tel: 34 1 321 6000
Fax: 34 1 321 6002

3M Greece (Athens)
3M Hellas Ltd
20 Kifissias Avenue
151 25 Paradissos
Maroussi - Athens
Greece
Tel: 00 30 1 6842902
Fax: 00 30 1 6843281

3M is a trademark.
CompactFlash is a trademark of
SanDisk Corporation
Printed in the UK.
© 3M United Kingdom PLC.
November 1996. Issue 1.
Ref. DS35/000102-1.
Literature Code FF30.

Technical Data

3M Part Number 20468-0000-00 (without 3M label)
20468-0000-11 (with 3M label)

Specification Sheet Number TS-0662-04

Components	Material
Frame	Glass Reinforced Polyester (PBT) UL 94V-0, Black
Covers	Stainless Steel

Environmental	Rating
Operating Temperature	0°C to 55°C under 95% (non-condensing) RH
Storage Temperature	-40°C to 70°C under 95% (non-condensing) RH

- PCMCIA/JEIDA PC card standard
- Converts CompactFlash™ card to PC card
- Compatible with PC card slot (Type-II)
- Protective stainless steel covers - rugged and reliable

All questions of liability relating to 3M products are governed by the seller's terms of sale subject where applicable to the prevailing law.

If any goods supplied or processed by or on behalf of 3M prove on inspection to be defective in material or workmanship, 3M will (at its option) replace the same or refund to the Buyer the price of the goods or services. Except as set out above, all warranties and conditions, whether express or implied, statutory or otherwise are excluded to the fullest extent permissible at law.