

## SBS 1.1-COMPLIANT GAS GAUGE AND PROTECTION-ENABLED IC WITH IMPEDANCE TRACK™

### FEATURES

- **Next Generation Patented Impedance Track™ Technology accurately Measures Available Charge in Li-Ion and Li-Polymer Batteries**
  - **Better than 1% Error Over Lifetime of the Battery**
  - **Instant Accuracy – No Learning Cycle Required**
- **Supports the Smart Battery Specification SBS V1.1**
- **Flexible Configuration for 2 to 4 Series Li-Ion and Li-Polymer Cells**
- **Powerful 8-Bit RISC CPU With Ultra-Low Power Modes**
- **Full Array of Programmable Protection Features**
  - **Voltage, Current and Temperature**
- **Supports SHA-1 Authentication**
- **small 38-Pin TSSOP (DBT) Package**

### APPLICATIONS

- **Notebook PCs**
- **Medical and Test Equipment**
- **Portable Instrumentation**

### DESCRIPTION

The bq20z75 SBS-compliant gas gauge and protection IC is a single IC solution designed for battery-pack or in-system installation. The bq20z75 measures and maintains an accurate record of available charge in Li-ion or Li-polymer batteries using its integrated high-performance analog peripherals, monitors capacity change, battery impedance, open-circuit voltage, and other critical parameters of the battery pack as well and reports the information to the system host controller over a serial-communication bus. Together with the integrated analog front-end (AFE) short-circuit and overload protection the bq20z75 maximizes functionality, safety and minimize external component count, cost and size in smart battery circuits.

The implemented Impedance Track™ gas gauging technology continuously analyzes the battery impedance, resulting in superior gas-gauging accuracy. This enables remaining capacity to be calculated with discharge rate, temperature, and cell aging all accounted for during each stage of every cycle with high accuracy.

### AVAILABLE OPTIONS

T <sub>A</sub>	PACKAGE	
	38-PIN TSSOP (DBT) Tube <sup>(1)</sup>	38-PIN TSSOP (DBT) Tape and Reel <sup>(2)</sup>
–40°C to 85°C	bq20z75DBT	bq20z75DBTR
	bq20z75DBT-v160	bq20z75DBTR-v160

- (1) A single tube quantity is 50 units.  
 (2) A single reel quantity is 2000 units



Please be aware that an important notice concerning availability, standard warranty, and use in critical applications of Texas Instruments semiconductor products and disclaimers thereto appears at the end of this data sheet.

IMPEDANCE TRACK is a trademark of Texas Instruments.



These devices have limited built-in ESD protection. The leads should be shorted together or the device placed in conductive foam during storage or handling to prevent electrostatic damage to the MOS gates.

### SYSTEM PARTITIONING DIAGRAM

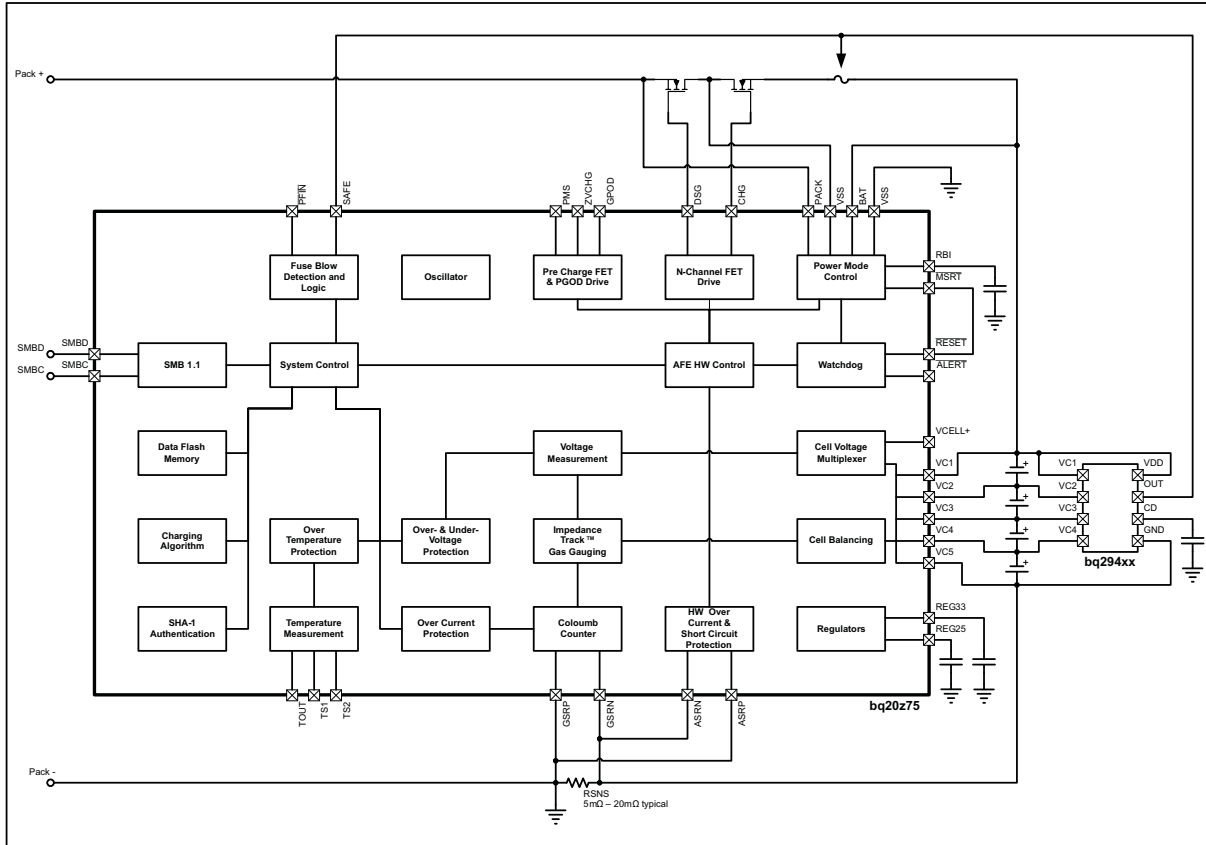

TSSOP (PW)  
(TOP VIEW)

DSG	1	38	CHG
PACK	2	37	BAT
VCC	3	36	VC1
ZVCHG	4	35	VC2
GPOD	5	34	VC3
PMS	6	33	VC4
VSS	7	32	VC5
REG33	8	31	ASRP
TOUT	9	30	ASRN
VCELL+	10	29	RESET
ALERT	11	28	VSS
PRES	12	27	RBI
TS1	13	26	REG25
TS2	14	25	VSS
PFIN	15	24	MRST
SAFE	16	23	GSRN
SMBD	17	22	GSRP
SMBC	18	21	VSS
NC	19	20	VSS

**TERMINAL FUNCTIONS**

TERMINAL		I/O <sup>(1)</sup>	DESCRIPTION
NO.	NAME		
1	DSG	O	High side N-channel discharge FET gate drive
2	PACK	IA, P	Battery pack input voltage sense input. It also serves as device wake up when device is in shutdown mode.
3	VCC	P	Positive device supply input. Connect to the center connection of the CHG FET and DSG FET to ensure device supply either from battery stack or battery pack input
4	ZVCHG	O	P-channel pre-charge FET gate drive
5	GPOD	OD	High voltage general purpose open drain output. Can be configured to be used in pre-charge condition
6	PMS	I	Pre-charge mode setting input. Connect to PACK to enable 0v pre-charge using charge FET connected at CHG pin. Connect to VSS to disable 0V pre-charge using charge FET connected at CHG pin.
7	VSS	P	Negative device power supply input. Connect all VSS pins together for operation of device
8	REG33	P	3.3V regulator output. Connect at least a 2.2μF capacitor to REG33 and VSS
9	TOUT	P	Termistor bias supply output
10	VCELL+	-	Internal cell voltage multiplexer and amplifier output. Connect a 0.1μF capacitor to VCELL+ and VSS
11	$\overline{\text{ALERT}}$	I/OD	Alert output. In case of short circuit condition, overload condition and watchdog time out this pin will be triggered.
12	$\overline{\text{PRES}}$	I/OD	System / Host present input. Pull up to TOUT
13	TS1	IA	Temperature sensor 1 input
14	TS2	IA	Temperature sensor 2 input
15	$\overline{\text{PFIN}}$	I/OD	Fuse blow detection input
16	SAFE	I/OD	blow fuse signal output
17	SMBD	I/OD	SMBus data line
18	SMBC	I/OD	SMBus clock line
19	NC	-	Not Connected
20	VSS	P	Negative device power supply input. Connect all VSS pins together for operation of device.
21	VSS	P	Negative device power supply input. Connect all VSS pins together for operation of device.
22	GSRP	IA	Coulomb counter differential input. Connect to one side of the sense resistor
23	GSRN	IA	Coulomb counter differential input. Connect to one side of the sense resistor
24	$\overline{\text{MRST}}$	I	Reset input for internal CPU core. connect to $\overline{\text{RESET}}$ for correct operation of device.
25	VSS	P	Negative device power supply input. Connect all VSS pins together for operation of device.
26	REG25	P	2.5V regulator output. Connect at least a 1μF capacitor to REG25 and VSS
27	RBI	P	RAM backup input. Connect a capacitor to this pin and VSS to protect loss of RAM data in case of short-circuit condition
28	VSS	P	Negative device power supply input. Connect all VSS pins together for operation of device
29	$\overline{\text{RESET}}$	O	Reset output. Connect to $\overline{\text{MRST}}$ .
30	ASRN	IA	Short-circuit and overload detection differential input
31	ASRP	IA	Short-circuit and overload detection differential input
32	VC5	IA,P	Cell voltage sense input and cell balancing input for the negative voltage of the bottom cell in cell stack.
33	VC4	IA,P	Cell voltage sense input and cell balancing input for the positive voltage of the bottom cell and the negative voltage of the second lowest cell in cell stack.
34	VC3	IA,P	Cell voltage sense input and cell balancing input for the positive voltage of the second lowest cell in cell stack and the negative voltage of the second highest cell in 4 cell applications.
35	VC2	IA,P	Cell voltage sense input and cell balancing input for the positive voltage of the second highest cell and the negative voltage of the highest cell in 4 cell applications. Connect to VC3 in 2 cell stack applications
36	VC1	IA,P	Cell voltage sense input and cell balancing input for the positive voltage of the highest cell in cell stack in 4 cell applications. Connect to VC2 in 3 or 2 cell stack applications

(1) I = Input, IA = Analog input, I/O = Input/output, I/OD = Input/Open-drain output, O = Output, OA = Analog output, P = Power

**TERMINAL FUNCTIONS (continued)**

TERMINAL		I/O <sup>(1)</sup>	DESCRIPTION
NO.	NAME		
37	BAT	O	Battery stack voltage sense input
38	CHG	O	High side N-channel charge FET gate drive

**Absolute Maximum Ratings**Over Operating Free-Air Temperature (unless otherwise noted) <sup>(1)</sup>

	DESCRIPTION	PIN	UNIT
V <sub>MAX</sub>	Supply voltage range	VBAT, VCC	-0.3V to 34V
		PACK, PMS	-0.3V to 34V
		VC(n)-VC(n+1); n = 1, 2, 3, 4	-0.3V to 8.5V
		VC1, VC2, VC3, VC4	-0.3V to 34V
		VC5	-0.3V to 1.0V
V <sub>IN</sub>	Input voltage range	$\overline{\text{PFIN}}$ , SMBD, SMBC, DISP	-0.3V to 6.0V
		TS1, TS2, VCELL+, PRES, ALERT	-0.3 V to V <sub>REG25</sub> + 0.3 V
		$\overline{\text{MRST}}$ , GSRN, GSRP, RBI	-0.3 V to V <sub>REG25</sub> + 0.3 V
		ASRN, ASRP	-1.0V to 1.0V
		DSG, CHG, GPOD	-0.3V to 34V
V <sub>OUT</sub>	Output voltage range	ZVCHG	-0.3V to V <sub>BAT</sub>
		TOUT, $\overline{\text{ALERT}}$ , REG33,	-0.3 V to 6.0V
		$\overline{\text{RESET}}$	-0.3 V to 7.0V
		REG25, SAFE, TOUT	-0.3V to 2.75V
I <sub>SS</sub>	Maximum combined sink current for input pins	$\overline{\text{PRES}}$ , $\overline{\text{PFIN}}$ , SMBD, SMBC	50mA
T <sub>A</sub>	Operating free-air temperature range		-40°C to 85°C
T <sub>F</sub>	Functional temperature		-40°C to 100°C
T <sub>stg</sub>	Storage temperature range		-65°C to 150°C
T <sub>slid</sub>	Lead temperature (soldering, 10s)		300°C

(1) Stresses beyond those listed under *absolute maximum ratings* may cause permanent damage to the device. These are stress ratings only, and functional operation of the device at these or any other conditions beyond those indicated under *recommended operating conditions* is not implied. Exposure to absolute-maximum-rated conditions for extended periods may affect device reliability.

## Recommended Operating Conditions

over operating free-air temperature range (unless otherwise noted)

PARAMETER		PIN	MIN	NOM	MAX	UNIT
V <sub>SUP</sub>	Supply voltage	VCC, VBAT	4.5		25	V
V <sub>STARTUP</sub>	Minimum startup voltage	VCC, BAT, PACK	5.5			V
V <sub>IN</sub>	Input Voltage Range	VC(n)–VC(n+1); n = 1,2,3,4	0		5	V
		VC1, VC2, VC3, VC4	0		V <sub>SUP</sub>	V
		VC5	0		0.5	V
		ASRN, ASRP	–0.5		0.5	V
		PACK, PMS	0		25	V
V <sub>GPOD</sub>	Output Voltage Range	GPOD	0		25	V
A <sub>GPOD</sub>	Drain Current <sup>(1)</sup>	GPOD			1	mA
C <sub>REG25</sub>	2.5V LDO Capacitor	REG25	1			μF
C <sub>REG33</sub>	3.3V LDO Capacitor	REG33	2.2			μF
C <sub>VCELL+</sub>	Cell Voltage Output Capacitor	VCELL+	0.1			μF
C <sub>PACK</sub>	PACK input block resistor <sup>(2)</sup>	PACK	1			kΩ

(1) Use external resistor to limit current to GPOD to 1mA in high voltage application.

(2) External resistor to limit inrush current PACK pin required.

## Electrical Characteristics

over operating free-air temperature range (unless otherwise noted), T<sub>A</sub> = –40°C to 85°C, V<sub>REG25</sub> = 2.41 V to 2.59 V, V<sub>BAT</sub> = 14V, C<sub>REG25</sub> = 1μF, C<sub>REG33</sub> = 2.2μF; typical values at T<sub>A</sub> = 25°C (unless otherwise noted)

PARAMETER		TEST CONDITIONS	MIN	TYP	MAX	UNIT
<b>SUPPLY CURRENT</b>						
I <sub>NORMAL</sub>	Firmware running			550		μA
I <sub>SLEEP</sub>	Sleep Mode	CHG FET on; DSG FET on		124		μA
		CHG FET off; DSG FET on		90		μA
		CHG FET off; DSG FET off		52		μA
I <sub>SHUTDOWN</sub>	Shutdown Mode		0.1	1		μA
<b>SHUTDOWN WAKE; T<sub>A</sub> = 25°C (unless otherwise noted)</b>						
I <sub>PACK</sub>	Shutdown exit at V <sub>STARTUP</sub> threshold				1	μA
<b>SRx WAKE FROM SLEEP; T<sub>A</sub> = 25°C (unless otherwise noted)</b>						
V <sub>WAKE</sub>	Positive or negative wake threshold with 1.00 mV, 2.25 mV, 4.5 mV and 9 mV programmable options		1.25		10	mV
V <sub>WAKE_ACR</sub>	Accuracy of V <sub>WAKE</sub>	V <sub>WAKE</sub> = 1.0mV; IWAKE=0, RSNS1=0, RSNS0=1;	–0.7		0.7	mV
		V <sub>WAKE</sub> = 2.25mV; IWAKE =1, RSNS1=0, RSNS0=1; IWAKE =0, RSNS1=1, RSNS0=0;	–0.8		0.8	
		V <sub>WAKE</sub> = 4.5mV; IWAKE =1, RSNS1=1, RSNS0=1; IWAKE =0, RSNS1=1, RSNS0=0;	–1.0		1.0	
		V <sub>WAKE</sub> = 9mV; IWAKE =1, RSNS1=1, RSNS0=1;	–1.4		1.4	
V <sub>WAKE_TCO</sub>	Temperature drift of V <sub>WAKE</sub> accuracy			0.5		%/°C
t <sub>WAKE</sub>	Time from application of current and wake of bq20z75			1	10	ms
<b>POWER-ON RESET</b>						
V <sub>IT-</sub>	Negative-going voltage input	Voltage at REG25 pin	1.70	1.80	1.90	V

## Electrical Characteristics (continued)

over operating free-air temperature range (unless otherwise noted),  $T_A = -40^\circ\text{C}$  to  $85^\circ\text{C}$ ,  $V_{\text{REG25}} = 2.41\text{ V}$  to  $2.59\text{ V}$ ,  $V_{\text{BAT}} = 14\text{V}$ ,  $C_{\text{REG25}} = 1\mu\text{F}$ ,  $C_{\text{REG33}} = 2.2\mu\text{F}$ ; typical values at  $T_A = 25^\circ\text{C}$  (unless otherwise noted)

PARAMETER		TEST CONDITIONS	MIN	TYP	MAX	UNIT
$V_{\text{hys}}$	Hysteresis	$V_{\text{IT+}} - V_{\text{IT-}}$	50	150	250	mV
$t_{\text{RST}}$	$\overline{\text{RESET}}$ active low time	active low time after power up or watchdog reset	100	250	560	$\mu\text{s}$
<b>WATCHDOG TIMER</b>						
$t_{\text{WDTINT}}$	Watchdog start up detect time		250	500	1000	ms
$t_{\text{WDWT}}$	Watchdog detect time		50	100	150	$\mu\text{s}$
<b>2.5V LDO; <math>I_{\text{REG33OUT}} = 0\text{mA}</math>; <math>T_A = 25^\circ\text{C}</math> (unless otherwise noted)</b>						
$V_{\text{REG25}}$	Regulator output voltage	$4.5 < \text{VCC or BAT} < 25\text{V}$ ; $I_{\text{REG25OUT}} \leq 16\text{mA}$ ; $T_A = -40^\circ\text{C}$ to $100^\circ\text{C}$	2.41	2.5	2.59	V
$\Delta V_{\text{REG25}} / \text{TEMP}$	Regulator output change with temperature	$I_{\text{REG25OUT}} = 2\text{mA}$ ; $T_A = -40^\circ\text{C}$ to $100^\circ\text{C}$		$\pm 0.2$		%
$\Delta V_{\text{REG25L}} / \text{INE}$	Line regulation	$5.4 < \text{VCC or BAT} < 25\text{V}$ ; $I_{\text{REG25OUT}} = 2\text{mA}$		3	10	mV
$\Delta V_{\text{REG25L}} / \text{OAD}$	Load Regulation	$0.2\text{mA} \leq I_{\text{REG25OUT}} \leq 2\text{mA}$ $0.2\text{mA} \leq I_{\text{REG25OUT}} \leq 16\text{mA}$		7 15	25 50	mV
$I_{\text{REG25MAX}}$	Current Limit	drawing current until REG25 = 2V to 0V	5	40	75	mA
<b>3.3V LDO; <math>I_{\text{REG25OUT}} = 0\text{mA}</math>; <math>T_A = 25^\circ\text{C}</math> (unless otherwise noted)</b>						
$V_{\text{REG33}}$	Regulator output voltage	$4.5 < \text{VCC or BAT} < 25\text{V}$ ; $I_{\text{REG33OUT}} \leq 25\text{mA}$ ; $T_A = -40^\circ\text{C}$ to $100^\circ\text{C}$	3	3.3	3.6	V
$\Delta V_{\text{REG33}} / \text{TEMP}$	Regulator output change with temperature	$I_{\text{REG33OUT}} = 2\text{mA}$ ; $T_A = -40^\circ\text{C}$ to $100^\circ\text{C}$		$\pm 0.2$		%
$\Delta V_{\text{REG33L}} / \text{INE}$	Line regulation	$5.4 < \text{VCC or BAT} < 25\text{V}$ ; $I_{\text{REG33OUT}} = 2\text{mA}$		3	17	mV
$\Delta V_{\text{REG33L}} / \text{OAD}$	Load Regulation	$0.2\text{mA} \leq I_{\text{REG33OUT}} \leq 2\text{mA}$ $0.2\text{mA} \leq I_{\text{REG33OUT}} \leq 25\text{mA}$		7 40	17 100	mV
$I_{\text{REG33MAX}}$	Current Limit	drawing current until REG33 = 3V short REG33 to VSS, REG33 = 0V	25 12	100	145 65	mA
<b>THERMISTOR DRIVE</b>						
$V_{\text{TOUT}}$	Output voltage	$I_{\text{TOUT}} = 0\text{mA}$ ; $T_A = 25^\circ\text{C}$		$V_{\text{REG25}}$		V
$R_{\text{DS(ON)}}$	TOUT pass element resistance	$I_{\text{TOUT}} = 1\text{mA}$ ; $R_{\text{DS(ON)}} = (V_{\text{REG25}} - V_{\text{TOUT}}) / 1\text{mA}$ ; $T_A = -40^\circ\text{C}$ to $100^\circ\text{C}$		50	100	$\Omega$
<b>VCELL+ HIGH VOLTAGE TRANSLATION</b>						
$V_{\text{VCELL+OUT}}$	Translation output	$\text{VC}(n) - \text{VC}(n+1) = 0\text{V}$ ; $T_A = -40^\circ\text{C}$ to $100^\circ\text{C}$	0.950	0.975	1	V
		$\text{VC}(n) - \text{VC}(n+1) = 4.5\text{V}$ ; $T_A = -40^\circ\text{C}$ to $100^\circ\text{C}$	0.275	0.3	0.375	
$V_{\text{VCELL+REF}}$		internal AFE reference voltage; $T_A = -40^\circ\text{C}$ to $100^\circ\text{C}$	0.965	0.975	0.985	
$V_{\text{VCELL+PACK}}$		Voltage at PACK pin; $T_A = -40^\circ\text{C}$ to $100^\circ\text{C}$	$0.98 \cdot V_{\text{PAC}} / 18$	$V_{\text{PACK}} / 18$	$1.02 \cdot V_{\text{PACK}} / 18$	
$V_{\text{VCELL+BAT}}$		Voltage at BAT pin; $T_A = -40^\circ\text{C}$ to $100^\circ\text{C}$	$0.98 \cdot V_{\text{BAT}} / 18$	$V_{\text{BAT}} / 18$	$1.02 \cdot V_{\text{BAT}} / 18$	
CMMR	Common mode rejection ratio	VCELL+	40			dB
K	Cell scale factor	$K = \{ \text{VCELL+ output (VC5=0V; VC4=4.5V)} - \text{VCELL+ output (VC5=0V; VC4=0V)} \} / 4.5$	0.147	0.150	0.153	
		$K = \{ \text{VCELL+ output (VC2=13.5V; VC1=18V)} - \text{VCELL+ output (VC5=13.5V; VC1=13.5V)} \} / 4.5$	0.147	0.150	0.153	

**Electrical Characteristics (continued)**

over operating free-air temperature range (unless otherwise noted),  $T_A = -40^{\circ}\text{C}$  to  $85^{\circ}\text{C}$ ,  $V_{\text{REG25}} = 2.41\text{ V}$  to  $2.59\text{ V}$ ,  $V_{\text{BAT}} = 14\text{V}$ ,  $C_{\text{REG25}} = 1\mu\text{F}$ ,  $C_{\text{REG33}} = 2.2\mu\text{F}$ ; typical values at  $T_A = 25^{\circ}\text{C}$  (unless otherwise noted)

PARAMETER		TEST CONDITIONS	MIN	TYP	MAX	UNIT
$I_{\text{VCELL+OU T}}$	Drive Current to VCELL+ capacitor	$\text{VC}(n) - \text{VC}(n+1) = 0\text{V}$ ; $\text{VCELL+} = 0\text{V}$ ; $T_A = -40^{\circ}\text{C}$ to $100^{\circ}\text{C}$	12	18		$\mu\text{A}$
$V_{\text{VCELL+O}}$	CELL offset error	CELL output ( $\text{VC2} = \text{VC1} = 18\text{V}$ ) – CELL output ( $\text{VC2} = \text{VC1} = 0\text{V}$ )	-18	-1	18	mV
$I_{\text{VCnL}}$	VC(n) pin leakage current	VC1, VC2, VC3, VC4, VC5 = 3V	-1	0.01	1	$\mu\text{A}$
<b>CELL BALANCING</b>						
$R_{\text{BAL}}$	internal cell balancing FET resistance	$R_{\text{DS(on)}}$ for internal FET switch at $V_{\text{DS}} = 2\text{V}$ ; $T_A = 25^{\circ}\text{C}$	200	400	600	$\Omega$
<b>HARDWARE SHORT CIRCUIT AND OVERLOAD PROTECTION; <math>T_A = 25^{\circ}\text{C}</math> (unless otherwise noted)</b>						
$V_{\text{(OL)}}$	OL detection threshold voltage accuracy	$V_{\text{OL}} = 25\text{mV}$ (min)	15	25	35	mV
		$V_{\text{OL}} = 100\text{mV}$ ; $\text{RSNS} = 0, 1$	90	100	110	
		$V_{\text{OL}} = 205\text{mV}$ (max)	185	205	225	
$V_{\text{(SCC)}}$	SCC detection threshold voltage accuracy	$V_{\text{SCC}} = 50\text{mV}$ (min)	30	50	70	mV
		$V_{\text{SCC}} = 200\text{mV}$ ; $\text{RSNS} = 0, 1$	180	200	220	
		$V_{\text{SCC}} = 475\text{mV}$ (max)	428	475	523	
$V_{\text{(SCD)}}$	SCD detection threshold voltage accuracy	$V_{\text{SCD}} = -50\text{mV}$ (min)	-30	-50	-70	mV
		$V_{\text{SCD}} = -200\text{mV}$ ; $\text{RSNS} = 0, 1$	-180	-200	-220	
		$V_{\text{SCD}} = -475\text{mV}$ (max)	-428	-475	-523	
$t_{\text{da}}$	Delay time accuracy		±15.25			$\mu\text{s}$
$t_{\text{pd}}$	Protection circuit propagation delay		50			$\mu\text{s}$
<b>FET DRIVE CIRCUIT; <math>T_A = 25^{\circ}\text{C}</math> (unless otherwise noted)</b>						
$V_{\text{DSGON}}$	DSG pin output on voltage	$V_{\text{DSGON}} = V_{\text{DSG}} - V_{\text{PACK}}$ ; $V_{\text{GS}} = 10\text{M}\Omega$ ; DSG and CHG on; $T_A = -40^{\circ}\text{C}$ to $100^{\circ}\text{C}$	8	12	16	V
$V_{\text{CHGON}}$	CHG pin output on voltage	$V_{\text{CHGON}} = V_{\text{CHG}} - V_{\text{BAT}}$ ; $V_{\text{GS}} = 10\text{M}\Omega$ ; DSG and CHG on; $T_A = -40^{\circ}\text{C}$ to $100^{\circ}\text{C}$	8	12	16	V
$V_{\text{DSGOFF}}$	DSG pin output off voltage	$V_{\text{DSGOFF}} = V_{\text{DSG}} - V_{\text{PACK}}$			0.2	V
$V_{\text{CHGOFF}}$	CHG pin output off voltage	$V_{\text{CHGOFF}} = V_{\text{CHG}} - V_{\text{BAT}}$			0.2	V
$t_{\text{R}}$	Rise time	$C_{\text{L}} = 4700\text{pF}$ ; $V_{\text{PACK}} \leq \text{DSG} \leq V_{\text{PACK}} + 4\text{V}$		400	1000	$\mu\text{s}$
		$C_{\text{L}} = 4700\text{pF}$ ; $V_{\text{BAT}} \leq \text{CHG} \leq V_{\text{BAT}} + 4\text{V}$		400	1000	
$t_{\text{F}}$	Fall time	$C_{\text{L}} = 4700\text{pF}$ ; $V_{\text{PACK}} + V_{\text{DSGON}} \leq \text{DSG} \leq V_{\text{PACK}} + 1\text{V}$		40	200	$\mu\text{s}$
		$C_{\text{L}} = 4700\text{pF}$ ; $V_{\text{BAT}} + V_{\text{CHGON}} \leq \text{CHG} \leq V_{\text{BAT}} + 1\text{V}$		40	200	
$V_{\text{ZVCHG}}$	ZVCHG clamp voltage	BAT = 4.5V	3.3	3.5	3.7	V
<b>LOGIC; <math>T_A = -40^{\circ}\text{C}</math> to <math>100^{\circ}\text{C}</math> (unless otherwise noted)</b>						
$R_{\text{PULLUP}}$	Internal pullup resistance	$\overline{\text{ALERT}}$	60	100	200	k $\Omega$
		$\overline{\text{RESET}}$	1	3	6	
$V_{\text{OL}}$	Logic low output voltage level	$\overline{\text{ALERT}}$			0.2	V
		$\overline{\text{RESET}}$ ; $V_{\text{BAT}} = 7\text{V}$ ; $V_{\text{REG25}} = 1.5\text{V}$ ; $I_{\text{RESET}} = 200\mu\text{A}$			0.4	
		GPOD; $I_{\text{GPOD}} = 50\mu\text{A}$			0.6	
<b>LOGIC SMBC, SMBD, <math>\overline{\text{PFIN}}</math>, <math>\overline{\text{PRES}}</math>, SAFE, ALERT</b>						
$V_{\text{IH}}$	High-level input voltage		2.0			V
$V_{\text{IL}}$	Low-level input voltage				0.8	V

## Electrical Characteristics (continued)

over operating free-air temperature range (unless otherwise noted),  $T_A = -40^\circ\text{C}$  to  $85^\circ\text{C}$ ,  $V_{\text{REG25}} = 2.41\text{ V}$  to  $2.59\text{ V}$ ,  $V_{\text{BAT}} = 14\text{V}$ ,  $C_{\text{REG25}} = 1\mu\text{F}$ ,  $C_{\text{REG33}} = 2.2\mu\text{F}$ ; typical values at  $T_A = 25^\circ\text{C}$  (unless otherwise noted)

PARAMETER		TEST CONDITIONS	MIN	TYP	MAX	UNIT	
$V_{\text{OH}}$	Output voltage high <sup>(1)</sup>	SAFE, $I_L = -0.5\text{ mA}$	$V_{\text{REG25}} - 0.5$			V	
$V_{\text{OL}}$	Low-level output voltage	$\overline{\text{PRES}}, \overline{\text{PFIN}}, \overline{\text{ALERT}}, I_L = 7\text{ mA};$	0.4			V	
$C_1$	Input capacitance		5			pF	
$I_{(\text{SAFE})}$	SAFE source currents	SAFE active, $\text{SAFE} = V_{\text{REG25}} - 0.6\text{ V}$	-3			mA	
$I_{\text{kg}(\text{SAFE})}$	SAFE leakage current	SAFE inactive	-0.2			$\mu\text{A}$	
$I_{\text{kg}}$	Input leakage current		1			$\mu\text{A}$	
<b>ADC<sup>(2)</sup></b>							
	Input voltage range	TS1, TS2, using external $V_{\text{ref}}$	-0.2	$V_{\text{REG25}} + 0.2$		V	
	Conversion time		31.5			ms	
	Resolution (no missing codes)		16			bits	
	Effective resolution		14	15		bits	
	Integral nonlinearity		$\pm 0.03$			%FSR <sup>(3)</sup>	
	Offset error <sup>(4)</sup>		140			250	$\mu\text{V}$
	Offset error drift <sup>(4)</sup>	$T_A = 25^\circ\text{C}$ to $85^\circ\text{C}$	2.5			18	$\mu\text{V}/^\circ\text{C}$
	Full-scale error <sup>(5)</sup>		$\pm 0.1\%$			$\pm 0.7\%$	
	Full-scale error drift		50			PPM/ $^\circ\text{C}$	
	Effective input resistance <sup>(6)</sup>		8			M $\Omega$	
<b>COULOMB COUNTER</b>							
	Input voltage range		-0.20	0.20		V	
	Conversion time	Single conversion	250			ms	
	Effective resolution	Single conversion	15			bits	
	Integral nonlinearity	-0.1 V to 0.20 V	$\pm 0.007$			%FSR	
		-0.20 V to -0.1 V	$\pm 0.007$				
	Offset error <sup>(7)</sup>	$T_A = 25^\circ\text{C}$ to $85^\circ\text{C}$	10			$\mu\text{V}$	
	Offset error drift		0.4			2.45	$\mu\text{V}/^\circ\text{C}$
	Full-scale error <sup>(8)(9)</sup>		$\pm 0.35\%$				
	Full-scale error drift		150			PPM/ $^\circ\text{C}$	
	Effective input resistance <sup>(10)</sup>	$T_A = 25^\circ\text{C}$ to $85^\circ\text{C}$	2.5			M $\Omega$	
<b>INTERNAL TEMPERATURE SENSOR</b>							
$V_{(\text{TEMP})}$	Temperature sensor voltage <sup>(11)</sup>		-2.0			mV/ $^\circ\text{C}$	
<b>VOLTAGE REFERENCE</b>							
	Output voltage		1.215	1.225	1.230	V	
	Output voltage drift		65			PPM/ $^\circ\text{C}$	
<b>HIGH FREQUENCY OSCILLATOR</b>							
$f_{(\text{OSC})}$	Operating frequency		4.194			MHz	

(1) RC[0:7] bus

(2) Unless otherwise specified, the specification limits are valid at all measurement speed modes

(3) Full-scale reference

(4) Post-calibration performance and no I/O changes during conversion with SRN as the ground reference

(5) Uncalibrated performance. This gain error can be eliminated with external calibration.

(6) The A/D input is a switched-capacitor input. Since the input is switched, the effective input resistance is a measure of the average resistance.

(7) Post-calibration performance

(8) Reference voltage for the coulomb counter is typically  $V_{\text{ref}}/3.969$  at  $V_{\text{REG25}} = 2.5\text{ V}$ ,  $T_A = 25^\circ\text{C}$ .

(9) Uncalibrated performance. This gain error can be eliminated with external calibration.

(10) The CC input is a switched capacitor input. Since the input is switched, the effective input resistance is a measure of the average resistance.

(11)  $-53.7\text{ LSB}/^\circ\text{C}$



## Electrical Characteristics (continued)

over operating free-air temperature range (unless otherwise noted),  $T_A = -40^{\circ}\text{C}$  to  $85^{\circ}\text{C}$ ,  $V_{\text{REG25}} = 2.41\text{ V}$  to  $2.59\text{ V}$ ,  $V_{\text{BAT}} = 14\text{ V}$ ,  $C_{\text{REG25}} = 1\mu\text{F}$ ,  $C_{\text{REG33}} = 2.2\mu\text{F}$ ; typical values at  $T_A = 25^{\circ}\text{C}$  (unless otherwise noted)

PARAMETER		TEST CONDITIONS	MIN	TYP	MAX	UNIT
$f_{(\text{EIO})}$	Frequency error <sup>(12)(13)</sup>		-3%	0.25%	3%	
		$T_A = 20^{\circ}\text{C}$ to $70^{\circ}\text{C}$	-2%	0.25%	2%	
$t_{(\text{SXO})}$	Start-up time <sup>(14)</sup>			2.5	5	ms
<b>LOW FREQUENCY OSCILLATOR</b>						
$f_{(\text{LOSC})}$	Operating frequency			32.768		kHz
$f_{(\text{LEIO})}$	Frequency error <sup>(13)(15)</sup>		-2.5%	0.25%	2.5%	
		$T_A = 20^{\circ}\text{C}$ to $70^{\circ}\text{C}$	-1.5%	0.25%	1.5%	
$t_{(\text{LSXO})}$	Start-up time <sup>(14)</sup>				500	$\mu\text{s}$

(12) The frequency error is measured from 4.194 MHz.

(13) The frequency drift is included and measured from the trimmed frequency at  $V_{\text{REG25}} = 2.5\text{ V}$ ,  $T_A = 25^{\circ}\text{C}$

(14) The startup time is defined as the time it takes for the oscillator output frequency to be  $\pm 3\%$

(15) The frequency error is measured from 32.768 kHz.

## Data Flash Characteristics Over Recommended Operating Temperature and Supply Voltage

Typical Values at  $T_A = 25^{\circ}\text{C}$  and  $V_{\text{REG25}} = 2.5\text{ V}$  (unless otherwise noted)

PARAMETER		TEST CONDITIONS	MIN	TYP	MAX	UNIT
	Data retention		10			Years
	Flash programming write-cycles		20k			Cycles
$t_{(\text{ROWPROG})}$	Row programming time	See <sup>(1)</sup>			2	ms
$t_{(\text{MASSERASE})}$	Mass-erase time				200	ms
$t_{(\text{PAGEERASE})}$	Page-erase time				20	ms
$I_{(\text{DDPROG})}$	Flash-write supply current			5	10	mA
$I_{(\text{DDERASE})}$	Flash-erase supply current		5	10	mA	
<b>RAM BACKUP</b>						
$I_{(\text{RB})}$	RB data-retention input current	$V_{(\text{RBI})} > V_{(\text{RBI})\text{MIN}}$ , $V_{\text{REG25}} < V_{\text{IT-}}$ , $T_A = 85^{\circ}\text{C}$		1000	2500	nA
		$V_{(\text{RBI})} > V_{(\text{RBI})\text{MIN}}$ , $V_{\text{REG25}} < V_{\text{IT-}}$ , $T_A = 25^{\circ}\text{C}$		90	220	
$V_{(\text{RB})}$	RB data-retention input voltage <sup>(1)</sup>		1.7			V

(1) Assured by design. Not production tested.

## SMBus Timing Characteristics

$T_A = -40^{\circ}\text{C}$  to  $85^{\circ}\text{C}$  Typical Values at  $T_A = 25^{\circ}\text{C}$  and  $V_{(\text{REG25})} = 2.5\text{ V}$  (Unless Otherwise Noted)

PARAMETER		TEST CONDITIONS	MIN	TYP	MAX	UNIT
$f_{\text{SMB}}$	SMBus operating frequency	Slave mode, SMBC 50% duty cycle	10		100	kHz
$f_{\text{MAS}}$	SMBus master clock frequency	Master mode, No clock low slave extend		51.2		kHz
$t_{(\text{BUF})}$	Bus free time between start and stop (see Figure 1)		4.7			$\mu\text{s}$
$t_{(\text{HD:STA})}$	Hold time after (repeated) start (see Figure 1)		4.0			$\mu\text{s}$
$t_{(\text{SU:STA})}$	Repeated start setup time (see Figure 1)		4.7			$\mu\text{s}$
$t_{(\text{SU:STO})}$	Stop setup time (see Figure 1)		4.0			$\mu\text{s}$
$t_{(\text{HD:DAT})}$	Data hold time (see Figure 1)	Receive mode	0			ns
		Transmit mode	300			
$t_{(\text{SU:DAT})}$	Data setup time (see Figure 1)		250			ns

### SMBus Timing Characteristics (continued)

T<sub>A</sub> = -40°C to 85°C Typical Values at T<sub>A</sub> = 25°C and V<sub>(REG25)</sub> = 2.5 V (Unless Otherwise Noted)

PARAMETER	TEST CONDITIONS	MIN	TYP	MAX	UNIT
t <sub>(TIMEOUT)</sub>	Error signal/detect (see Figure 1)	See <sup>(1)</sup>		35	μs
t <sub>(LOW)</sub>	Clock low period (see Figure 1)	4.7			μs
t <sub>(HIGH)</sub>	Clock high period (see Figure 1)	See <sup>(2)</sup>		50	μs
t <sub>(LOW:SEXT)</sub>	Cumulative clock low slave extend time	See <sup>(3)</sup>		25	μs
t <sub>(LOW:MEXT)</sub>	Cumulative clock low master extend time (see Figure 1)	See <sup>(4)</sup>		10	μs
t <sub>f</sub>	Clock/data fall time	See <sup>(5)</sup>		300	ns
t <sub>r</sub>	Clock/data rise time	See <sup>(6)</sup>		1000	ns

- (1) The bq20z75 times out when any clock low exceeds t<sub>(TIMEOUT)</sub>.
- (2) t<sub>(HIGH)</sub>, Max, is the minimum bus idle time. SMBC = SMBD = 1 for t > 50 ms causes reset of any transaction involving bq20z75 that is in progress. This specification is valid when the NC\_SMB control bit remains in the default cleared state (CLK[0]=0).
- (3) t<sub>(LOW:SEXT)</sub> is the cumulative time a slave device is allowed to extend the clock cycles in one message from initial start to the stop.
- (4) t<sub>(LOW:MEXT)</sub> is the cumulative time a master device is allowed to extend the clock cycles in one message from initial start to the stop.
- (5) Rise time t<sub>r</sub> = VILMAX - 0.15 to (VIHMIN + 0.15)
- (6) Fall time t<sub>f</sub> = 0.9V<sub>DD</sub> to (VILMAX - 0.15)

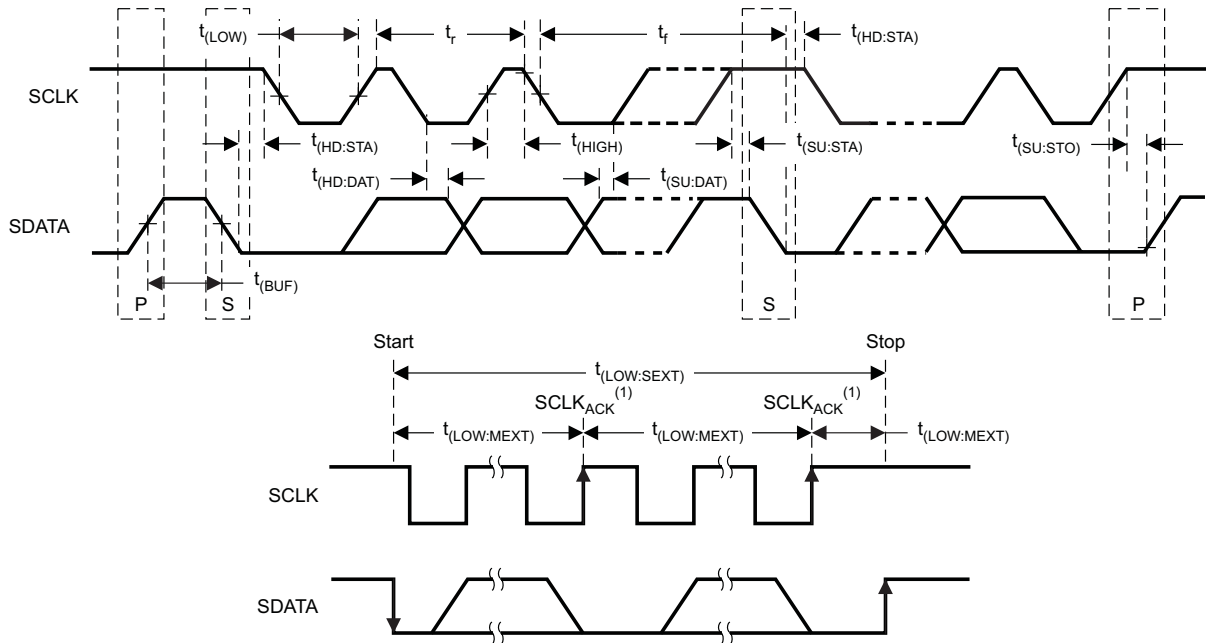

A. SCLK<sub>ACK</sub> is the acknowledge-related clock pulse generated by the master.

Figure 1. SMBus Timing Diagram

## FEATURE SET

### Primary (1st Level) Safety Features

The bq20z75 supports a wide range of battery and system protection features that can easily be configured. The primary safety features include:

- Cell over/under voltage protection
- Charge and Discharge over current
- Short Circuit
- Charge and Discharge Over temperature
- AFE Watchdog

### Secondary (2nd Level) Safety Features

The secondary safety features of the bq20z75 can be used to indicate more serious faults via the SAFE (pin 7). This pin can be used to blow an in-line fuse to permanently disable the battery pack from charging or discharging. The secondary safety protection features include:

- Safety overvoltage
- Safety overcurrent in Charge and Discharge
- Safety overtemperature in Charge and Discharge
- Charge FET and 0 Volt Charge FET fault
- Discharge FET fault
- AFE communication fault

### Charge Control Features

The bq20z75 charge control features include:

- Reports the appropriate charging current needed for constant current charging and the appropriate charging voltage needed for constant voltage charging to a smart charger using SMBus broadcasts.
- Determines the chemical state of charge of each battery cell using Impedance Track™ and can reduce the charge difference of the battery cells in fully charged state of the battery pack gradually using cell balancing algorithm during charging. This prevents fully charged cells from overcharging and causing excessive degradation and also increases the usable pack energy by preventing premature charge termination
- Supports pre-charging/zero-volt charging
- Support fast charging
- Supports charge inhibit and charge suspend if battery pack temperature is out of temperature range
- Reports charging fault and also indicate charge status via charge and discharge alarms.

### Gas Gauging

The bq20z75 uses the Impedance Track™ Technology to measure and calculate the available charge in battery cells. The achievable accuracy is better than 1% error over the lifetime of the battery and there is no full charge discharge learning cycle required.

See *Theory and Implementation of Impedance Track Battery Fuel-Gauging Algorithm* application note (SLUA364) for further details.

### Authentication

The bq20z75 supports authentication by the host using SHA-1.

### Power Modes

The bq20z75 supports 3 different power modes to reduce power consumption:

- In Normal Mode, the bq20z75 performs measurements, calculations, protection decisions and data updates in 1 second intervals. Between these intervals, the bq20z75 is in a reduced power stage.

- In Sleep Mode, the bq20z75 performs measurements, calculations, protection decisions and data update in adjustable time intervals. Between these intervals, the bq20z75 is in a reduced power stage. The bq20z75 has a wake function that enables exit from Sleep mode, when current flow or failure is detected.
- In Shutdown Mode the bq20z75 is completely disabled.

## CONFIGURATION

### Oscillator Function

The bq20z75 fully integrates the system oscillators. Therefore the bq20z75 requires no external components for this feature.

### System Present Operation

The bq20z75 checks the  $\overline{\text{PRES}}$  pin periodically (1 s). Connect the  $\overline{\text{PRES}}$  pin to TOUT with a 100k $\Omega$  resistor. If  $\overline{\text{PRES}}$  input is pulled to ground by external system host, the bq20z75 detects this as system present.

## BATTERY PARAMETER MEASUREMENTS

The bq20z75 uses an integrating delta-sigma analog-to-digital converter (ADC) for current measurement, and a second delta-sigma ADC for individual cell and battery voltage, and temperature measurement.

### Charge and Discharge Counting

The integrating delta-sigma ADC measures the charge/discharge flow of the battery by measuring the voltage drop across a small-value sense resistor between the SRP and SRN pins. The integrating ADC measures bipolar signals from  $-0.25$  V to  $0.25$  V. The bq20z75 detects charge activity when  $V_{\text{SR}} = V_{(\text{SRP})} - V_{(\text{SRN})}$  is positive and discharge activity when  $V_{\text{SR}} = V_{(\text{SRP})} - V_{(\text{SRN})}$  is negative. The bq20z75 continuously integrates the signal over time, using an internal counter. The fundamental rate of the counter is 0.65 nVh.

### Voltage

The bq20z75 updates the individual series cell voltages at one second intervals. The internal ADC of the bq20z75 measures the voltage, scales and calibrates it appropriately. This data is also used to calculate the impedance of the cell for the Impedance Track™ gas-gauging.

### Current

The bq20z75 uses the GSRP and GSRN inputs to measure and calculate the battery charge and discharge current using a 5 m $\Omega$  to 20 m $\Omega$  typ. sense resistor.

### Auto Calibration

The bq20z75 provides an auto-calibration feature to cancel the voltage offset error across GSRN and GSRP for maximum charge measurement accuracy. The bq20z75 performs auto-calibration when the SMBus lines stay low continuously for a minimum of 5 s.

### Temperature

The bq20z75 has an internal temperature sensor and 2 external temperature sensor inputs TS1 and TS2 used in conjunction with two identical NTC thermistors (default are Semitec 103AT) to sense the battery environmental temperature. The bq20z75 can be configured to use internal or external temperature sensors.

## COMMUNICATIONS

The bq20z75 uses SMBus v1.1 with Master Mode and package error checking (PEC) options per the SBS specification.

### SMBus On and Off State

The bq20z75 detects an SMBus off state when SMBC and SMBD are logic-low for  $\geq 2$  seconds. Clearing this state requires either SMBC or SMBD to transition high. Within 1 ms, the communication bus is available.

**SBS and Dataflash Values**
**Table 1. SBS COMMANDS**

SBS Cmd	Mode	Name	Format	Size in Bytes	Min Value	Max Value	Default Value	Unit
0x00	R/W	ManufacturerAccess	hex	2	0x0000	0xffff	—	
0x01	R/W	RemainingCapacityAlarm	unsigned int	2	0	65535	—	mAh or 10mWh
0x02	R/W	RemainingTimeAlarm	unsigned int	2	0	65535	—	min
0x03	R/W	BatteryMode	hex	2	0x0000	0xffff	—	
0x04	R/W	AtRate	signed int	2	–32768	32767	—	mA or 10mW
0x05	R	AtRateTimeToFull	unsigned int	2	0	65535	—	min
0x06	R	AtRateTimeToEmpty	unsigned int	2	0	65535	—	min
0x07	R	AtRateOK	unsigned int	2	0	65535	—	
0x08	R	Temperature	unsigned int	2	0	65535	—	0.1°K
0x09	R	Voltage	unsigned int	2	0	20000	—	mV
0x0a	R	Current	signed int	2	–32768	32767	—	mA
0x0b	R	AverageCurrent	signed int	2	–32768	32767	—	mA
0x0c	R	MaxError	unsigned int	1	0	100	—	%
0x0d	R	RelativeStateOfCharge	unsigned int	1	0	100	—	%
0x0e	R	AbsoluteStateOfCharge	unsigned int	1	0	100	—	%
0x0f	R/W	RemainingCapacity	unsigned int	2	0	65535	—	mAh or 10mWh
0x10	R	FullChargeCapacity	unsigned int	2	0	65535	—	mAh or 10mWh
0x11	R	RunTimeToEmpty	unsigned int	2	0	65535	—	min
0x12	R	AverageTimeToEmpty	unsigned int	2	0	65535	—	min
0x13	R	AverageTimeToFull	unsigned int	2	0	65535	—	min
0x14	R	ChargingCurrent	unsigned int	2	0	65535	—	mA
0x15	R	ChargingVoltage	unsigned int	2	0	65535	—	mV
0x16	R	BatteryStatus	unsigned int	2	0x0000	0xffff	—	
0x17	R/W	CycleCount	unsigned int	2	0	65535	—	
0x18	R/W	DesignCapacity	unsigned int	2	0	65535	—	mAh or 10mWh
0x19	R/W	DesignVoltage	unsigned int	2	7000	16000	14400	mV
0x1a	R/W	SpecificationInfo	unsigned int	2	0x0000	0xffff	0x0031	
0x1b	R/W	ManufactureDate	unsigned int	2	0	65535	0	
0x1c	R/W	SerialNumber	hex	2	0x0000	0xffff	-	
0x20	R/W	ManufacturerName	String	11+1	—	—	Texas Instruments	ASCII
0x21	R/W	DeviceName	String	7+1	—	—	bq20z75	ASCII
0x22	R/W	DeviceChemistry	String	4+1	—	—	LION	ASCII
0x23	R	ManufacturerData	String	14+1	—	—	—	ASCII
0x2f	R/W	Authenticate	String	20+1	—	—	—	ASCII
0x3c	R	CellVoltage4	unsigned int	2	0	65535	—	mV
0x3d	R	CellVoltage3	unsigned int	2	0	65535	—	mV
0x3e	R	CellVoltage2	unsigned int	2	0	65535	—	mV
0x3f	R	CellVoltage1	unsigned int	2	0	65535	—	mV

**Table 2. EXTENDED SBS COMMANDS**

SBS Cmd	Mode	Name	Format	Size in Bytes	Min Value	Max Value	Default Value	Unit
0x45	R	AFEData	String	11+1	—	—	—	ASCII
0x46	R/W	FETControl	hex	1	0x00	0xff	—	
0x4f	R	StateOfHealth	unsigned int	1	0	100	—	%
0x51	R	SafetyStatus	hex	2	0x0000	0xffff	—	
0x53	R	PFStatus	hex	2	0x0000	0xffff	—	
0x54	R	OperationStatus	hex	2	0x0000	0xffff	—	
0x55	R	ChargingStatus	hex	2	0x0000	0xffff	—	
0x57	R	ResetData	hex	2	0x0000	0xffff	—	
0x5a	R	PackVoltage	unsigned int	2	0	65535	—	mV
0x5d	R	AverageVoltage	unsigned int	2	0	65535	—	mV
0x60	R/W	UnSealKey	hex	4	0x00000000	0xffffffff	—	
0x61	R/W	FullAccessKey	hex	4	0x00000000	0xffffffff	—	
0x62	R/W	PFKey	hex	4	0x00000000	0xffffffff	—	
0x63	R/W	AuthenKey3	hex	4	0x00000000	0xffffffff	—	
0x64	R/W	AuthenKey2	hex	4	0x00000000	0xffffffff	—	
0x65	R/W	AuthenKey1	hex	4	0x00000000	0xffffffff	—	
0x66	R/W	AuthenKey0	hex	4	0x00000000	0xffffffff	—	
0x70	R/W	ManufacturerInfo	String	31+1	—	—	—	
0x71	R/W	SenseResistor	unsigned int	2	0	65535	—	$\mu\Omega$
0x77	R/W	DataFlashSubClassID	hex	2	0x0000	0xffff	—	
0x78	R/W	DataFlashSubClassPage1	hex	32	—	—	—	
0x79	R/W	DataFlashSubClassPage2	hex	32	—	—	—	
0x7a	R/W	DataFlashSubClassPage3	hex	32	—	—	—	
0x7b	R/W	DataFlashSubClassPage4	hex	32	—	—	—	
0x7c	R/W	DataFlashSubClassPage5	hex	32	—	—	—	
0x7d	R/W	DataFlashSubClassPage6	hex	32	—	—	—	
0x7e	R/W	DataFlashSubClassPage7	hex	32	—	—	—	
0x7f	R/W	DataFlashSubClassPage8	hex	32	—	—	—	

Application Schematics

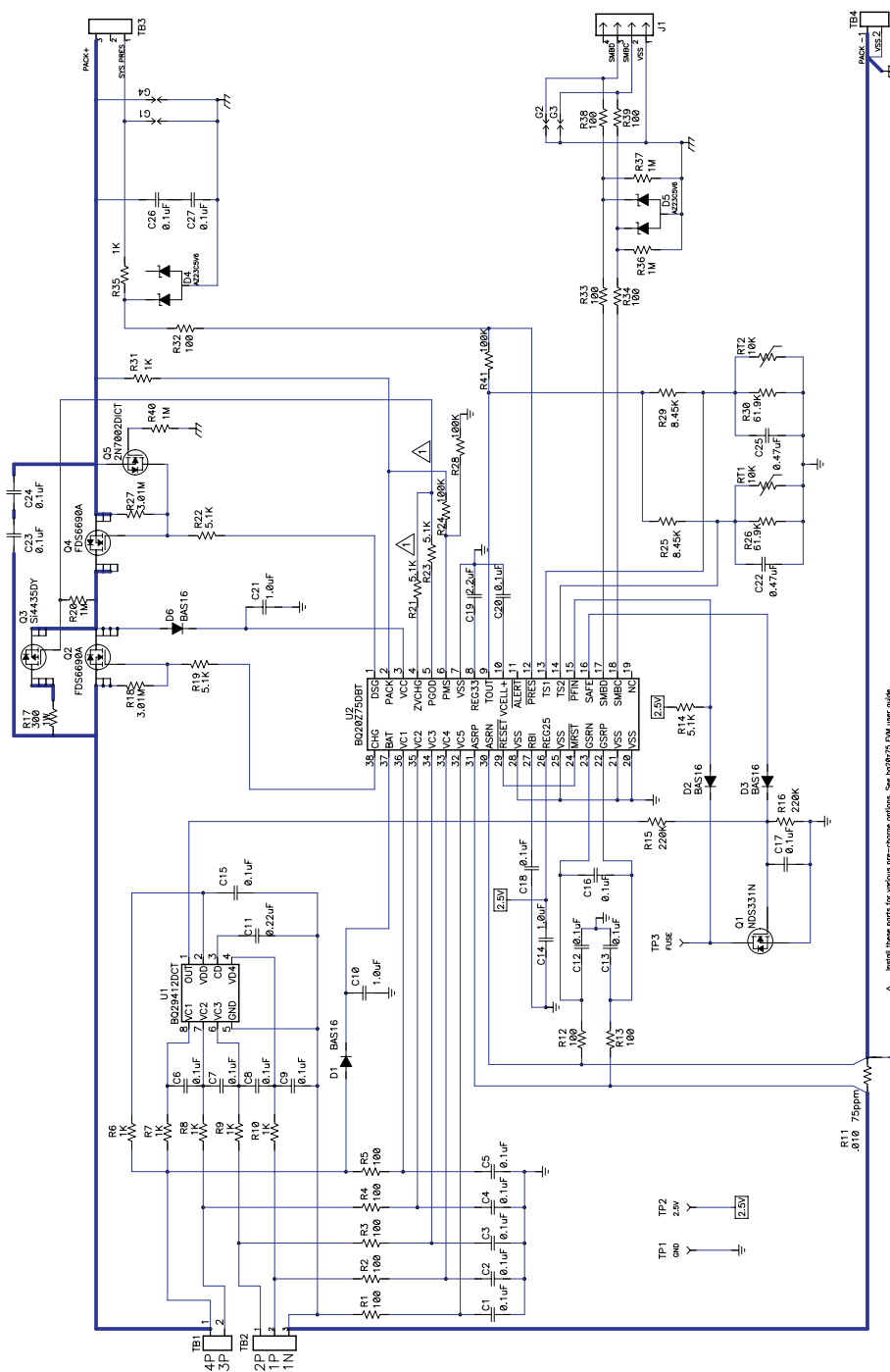

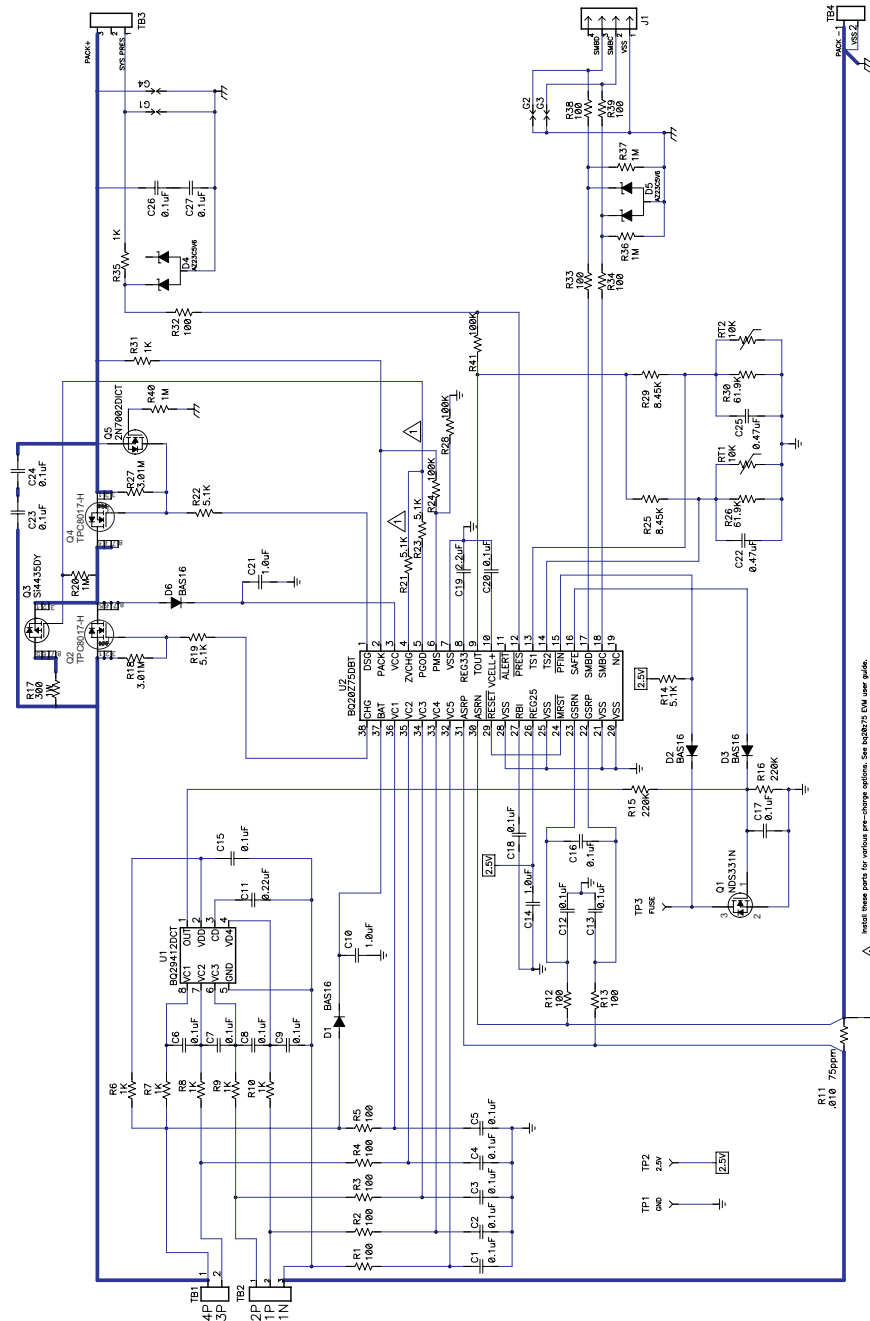



**PACKAGING INFORMATION**

Orderable Device	Status <sup>(1)</sup>	Package Type	Package Drawing	Pins	Package Qty	Eco Plan <sup>(2)</sup>	Lead/Ball Finish	MSL Peak Temp <sup>(3)</sup>
BQ20Z75DBT	NRND	TSSOP	DBT	38	50	Green (RoHS & no Sb/Br)	CU NIPDAU	Level-2-260C-1 YEAR
BQ20Z75DBT-V160	ACTIVE	TSSOP	DBT	38	50	Green (RoHS & no Sb/Br)	CU NIPDAU	Level-2-260C-1 YEAR
BQ20Z75DBTR	NRND	TSSOP	DBT	38	2000	Green (RoHS & no Sb/Br)	CU NIPDAU	Level-2-260C-1 YEAR
BQ20Z75DBTR-V160	ACTIVE	TSSOP	DBT	38	2000	Green (RoHS & no Sb/Br)	CU NIPDAU	Level-2-260C-1 YEAR

<sup>(1)</sup> The marketing status values are defined as follows:

**ACTIVE:** Product device recommended for new designs.

**LIFEBUY:** TI has announced that the device will be discontinued, and a lifetime-buy period is in effect.

**NRND:** Not recommended for new designs. Device is in production to support existing customers, but TI does not recommend using this part in a new design.

**PREVIEW:** Device has been announced but is not in production. Samples may or may not be available.

**OBSOLETE:** TI has discontinued the production of the device.

<sup>(2)</sup> Eco Plan - The planned eco-friendly classification: Pb-Free (RoHS), Pb-Free (RoHS Exempt), or Green (RoHS & no Sb/Br) - please check <http://www.ti.com/productcontent> for the latest availability information and additional product content details.

**TBD:** The Pb-Free/Green conversion plan has not been defined.

**Pb-Free (RoHS):** TI's terms "Lead-Free" or "Pb-Free" mean semiconductor products that are compatible with the current RoHS requirements for all 6 substances, including the requirement that lead not exceed 0.1% by weight in homogeneous materials. Where designed to be soldered at high temperatures, TI Pb-Free products are suitable for use in specified lead-free processes.

**Pb-Free (RoHS Exempt):** This component has a RoHS exemption for either 1) lead-based flip-chip solder bumps used between the die and package, or 2) lead-based die adhesive used between the die and leadframe. The component is otherwise considered Pb-Free (RoHS compatible) as defined above.

**Green (RoHS & no Sb/Br):** TI defines "Green" to mean Pb-Free (RoHS compatible), and free of Bromine (Br) and Antimony (Sb) based flame retardants (Br or Sb do not exceed 0.1% by weight in homogeneous material)

<sup>(3)</sup> MSL, Peak Temp. -- The Moisture Sensitivity Level rating according to the JEDEC industry standard classifications, and peak solder temperature.

**Important Information and Disclaimer:**The information provided on this page represents TI's knowledge and belief as of the date that it is provided. TI bases its knowledge and belief on information provided by third parties, and makes no representation or warranty as to the accuracy of such information. Efforts are underway to better integrate information from third parties. TI has taken and continues to take reasonable steps to provide representative and accurate information but may not have conducted destructive testing or chemical analysis on incoming materials and chemicals. TI and TI suppliers consider certain information to be proprietary, and thus CAS numbers and other limited information may not be available for release.

In no event shall TI's liability arising out of such information exceed the total purchase price of the TI part(s) at issue in this document sold by TI to Customer on an annual basis.

TAPE AND REEL INFORMATION

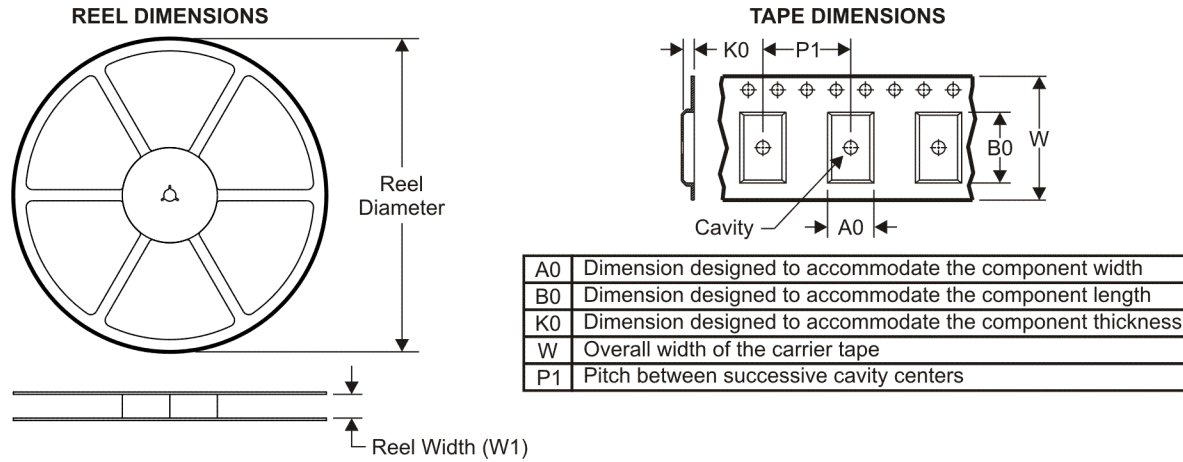

QUADRANT ASSIGNMENTS FOR PIN 1 ORIENTATION IN TAPE



\*All dimensions are nominal

Device	Package Type	Package Drawing	Pins	SPQ	Reel Diameter (mm)	Reel Width W1 (mm)	A0 (mm)	B0 (mm)	K0 (mm)	P1 (mm)	W (mm)	Pin1 Quadrant
BQ20Z75DBTR-V160	TSSOP	DBT	38	2000	330.0	16.4	6.9	10.2	1.8	12.0	16.0	Q1

**TAPE AND REEL BOX DIMENSIONS**



\*All dimensions are nominal

Device	Package Type	Package Drawing	Pins	SPQ	Length (mm)	Width (mm)	Height (mm)
BQ20Z75DBTR-V160	TSSOP	DBT	38	2000	346.0	346.0	33.0

## IMPORTANT NOTICE

Texas Instruments Incorporated and its subsidiaries (TI) reserve the right to make corrections, modifications, enhancements, improvements, and other changes to its products and services at any time and to discontinue any product or service without notice. Customers should obtain the latest relevant information before placing orders and should verify that such information is current and complete. All products are sold subject to TI's terms and conditions of sale supplied at the time of order acknowledgment.

TI warrants performance of its hardware products to the specifications applicable at the time of sale in accordance with TI's standard warranty. Testing and other quality control techniques are used to the extent TI deems necessary to support this warranty. Except where mandated by government requirements, testing of all parameters of each product is not necessarily performed.

TI assumes no liability for applications assistance or customer product design. Customers are responsible for their products and applications using TI components. To minimize the risks associated with customer products and applications, customers should provide adequate design and operating safeguards.

TI does not warrant or represent that any license, either express or implied, is granted under any TI patent right, copyright, mask work right, or other TI intellectual property right relating to any combination, machine, or process in which TI products or services are used. Information published by TI regarding third-party products or services does not constitute a license from TI to use such products or services or a warranty or endorsement thereof. Use of such information may require a license from a third party under the patents or other intellectual property of the third party, or a license from TI under the patents or other intellectual property of TI.

Reproduction of TI information in TI data books or data sheets is permissible only if reproduction is without alteration and is accompanied by all associated warranties, conditions, limitations, and notices. Reproduction of this information with alteration is an unfair and deceptive business practice. TI is not responsible or liable for such altered documentation. Information of third parties may be subject to additional restrictions.

Resale of TI products or services with statements different from or beyond the parameters stated by TI for that product or service voids all express and any implied warranties for the associated TI product or service and is an unfair and deceptive business practice. TI is not responsible or liable for any such statements.

TI products are not authorized for use in safety-critical applications (such as life support) where a failure of the TI product would reasonably be expected to cause severe personal injury or death, unless officers of the parties have executed an agreement specifically governing such use. Buyers represent that they have all necessary expertise in the safety and regulatory ramifications of their applications, and acknowledge and agree that they are solely responsible for all legal, regulatory and safety-related requirements concerning their products and any use of TI products in such safety-critical applications, notwithstanding any applications-related information or support that may be provided by TI. Further, Buyers must fully indemnify TI and its representatives against any damages arising out of the use of TI products in such safety-critical applications.

TI products are neither designed nor intended for use in military/aerospace applications or environments unless the TI products are specifically designated by TI as military-grade or "enhanced plastic." Only products designated by TI as military-grade meet military specifications. Buyers acknowledge and agree that any such use of TI products which TI has not designated as military-grade is solely at the Buyer's risk, and that they are solely responsible for compliance with all legal and regulatory requirements in connection with such use.

TI products are neither designed nor intended for use in automotive applications or environments unless the specific TI products are designated by TI as compliant with ISO/TS 16949 requirements. Buyers acknowledge and agree that, if they use any non-designated products in automotive applications, TI will not be responsible for any failure to meet such requirements.

Following are URLs where you can obtain information on other Texas Instruments products and application solutions:

### Products

Amplifiers	<a href="http://amplifier.ti.com">amplifier.ti.com</a>
Data Converters	<a href="http://dataconverter.ti.com">dataconverter.ti.com</a>
DSP	<a href="http://dsp.ti.com">dsp.ti.com</a>
Clocks and Timers	<a href="http://www.ti.com/clocks">www.ti.com/clocks</a>
Interface	<a href="http://interface.ti.com">interface.ti.com</a>
Logic	<a href="http://logic.ti.com">logic.ti.com</a>
Power Mgmt	<a href="http://power.ti.com">power.ti.com</a>
Microcontrollers	<a href="http://microcontroller.ti.com">microcontroller.ti.com</a>
RFID	<a href="http://www.ti-rfid.com">www.ti-rfid.com</a>
RF/IF and ZigBee® Solutions	<a href="http://www.ti.com/lprf">www.ti.com/lprf</a>

### Applications

Audio	<a href="http://www.ti.com/audio">www.ti.com/audio</a>
Automotive	<a href="http://www.ti.com/automotive">www.ti.com/automotive</a>
Broadband	<a href="http://www.ti.com/broadband">www.ti.com/broadband</a>
Digital Control	<a href="http://www.ti.com/digitalcontrol">www.ti.com/digitalcontrol</a>
Medical	<a href="http://www.ti.com/medical">www.ti.com/medical</a>
Military	<a href="http://www.ti.com/military">www.ti.com/military</a>
Optical Networking	<a href="http://www.ti.com/opticalnetwork">www.ti.com/opticalnetwork</a>
Security	<a href="http://www.ti.com/security">www.ti.com/security</a>
Telephony	<a href="http://www.ti.com/telephony">www.ti.com/telephony</a>
Video & Imaging	<a href="http://www.ti.com/video">www.ti.com/video</a>
Wireless	<a href="http://www.ti.com/wireless">www.ti.com/wireless</a>