

## LOW-POWER BATTERY BACKUP IC WITH INTEGRATED BOOST CONVERTER

### FEATURES

- Power-Path Switch to Select Main Battery or Backup Battery for Real-Time Clock (RTC)
- Integrated Boost DC/DC Converter
  - Modulation Select by Control Pin (PWMON), Pulse Frequency Modulation (PFM) or Pulse Width Modulation (PWM)
  - Fixed Switching Frequency (PWM, 750 kHz)
  - Peak Current Mode Control (PWM)
  - Low Power Consumption (PFM)
- Four Integrated Low Dropout (LDO) Voltage Regulators for 1.2 V/1.8 V/3.3 V
- Two Integrated Indicators
  - CS: Monitors the Voltage Level of Main Battery (VBAT) and Output voltage level of Boost Converter (VO\_BT)
  - XRESET: Monitors the Output voltage Level of 3.3V LDO (VOUT)
- 16-Pin QFN (3mm × 3mm) Package
- Operating Temperature –35°C to 85°C
- Protection
  - Overcurrent Protection (OCP)
  - Overvoltage Protection (OVP)
  - Thermal Shutdown (TSD)
  - Undervoltage Lockout (UVLO)

### APPLICATIONS

- Digital Still Cameras
- Portable Systems With Backup Battery

### DESCRIPTION

The TPS65510 offers a suitable solution for power switch to select the main battery or the backup battery.

This device automatically selects the power path. It depends on the voltage level of the VO\_BT pin. When the main battery is removed, the power path of the VOUT pin is automatically changed from the output of 3.3-V low dropout (LDO) voltage regulator to the backup battery.

The backup battery is charged from the power path of the VRO pin (output of 3.3-V LDO) via an external diode and resistor. The input of the LDO voltage regulator comes from the internal boost converter.

The 1.2-V output LDO and 1.8-V output LDO voltage regulators have a enable pin, V\_CTRL. If these outputs are not necessary, V\_CTRL should be connected to AGND to save power consumption. The self-power consumption is less than 3 μA (maximum) using the backup battery.

This device has two indicators. One is CS, which monitors the voltage level of the VBAT pin and VO\_BT pin. The other is XRESET, which monitors voltage level of the VOUT pin. These indicators should be connected to CPU/DSP to reset them.

This device reduces the total solution area and extends the lifetime of the backup battery.



Please be aware that an important notice concerning availability, standard warranty, and use in critical applications of Texas Instruments semiconductor products and disclaimers thereto appears at the end of this data sheet.

PowerPAD is a trademark of Texas Instruments.

PRODUCTION DATA information is current as of publication date. Products conform to specifications per the terms of the Texas Instruments standard warranty. Production processing does not necessarily include testing of all parameters.

Copyright © 2008, Texas Instruments Incorporated





**ORDERING INFORMATION**

T <sub>A</sub>	PACKAGE MARKING	PACKAGE	PART NUMBER
–35°C to 85°C	CGK	16-pin QFN	TPS65510RGT

**ABSOLUTE MAXIMUM RATINGS<sup>(1)</sup>**

over operating free-air temperature range (unless otherwise noted)

		MIN	MAX	UNIT
V <sub>BAT</sub> , V <sub>BK</sub>	Input voltage range	–0.3	6	V
SW		–0.3	7	
F <sub>B</sub> , F <sub>BG</sub>		–0.3	6	
P <sub>WMON</sub> , V <sub>CTRL</sub>		–0.3	6	
X <sub>RESET</sub> , CS	Output voltage range	–0.3	6	V
V <sub>RO</sub> , V <sub>OUT</sub> , V <sub>O1R8</sub> , V <sub>O1R2</sub>		–0.3	3.6	
V <sub>O_BT</sub>		–0.3	6	
SW	Switch current		1.3	A
Maximum junction temperature range			125	°C
Storage temperature range		–40	150	°C

(1) Stresses beyond those listed under "absolute maximum ratings" may cause permanent damage to the device. These are stress ratings only and functional operation of the device at these or any other conditions beyond those indicated under "recommended operating conditions" is not implied. Exposure to absolute-maximum-rated conditions for extended periods may affect device reliability.

**DISSIPATION RATINGS**

PACKAGE	R <sub>θJA</sub> <sup>(1)</sup>	POWER RATING T <sub>A</sub> < 25°C	POWER RATING T <sub>A</sub> = 85°C
QFN	47.4°C/W	2.11 W	0.844 W

(1) The thermal resistance, R<sub>θJA</sub>, is based on a soldered PowerPAD™ on 2S2P JEDEC board using thermal vias.

**RECOMMENDED OPERATING CONDITIONS**

over operating free-air temperature range (unless otherwise noted)

		MIN	TYP	MAX	UNIT
V <sub>BAT</sub>	Supply voltage	2.65		5.5	V
V <sub>BK</sub>		1.8		5.5	
V <sub>IH</sub>	High-level digital input voltage at P <sub>WMON</sub>	1.4		5.5	V
	High-level digital input voltage at V <sub>CTRL</sub>	1.4		V <sub>OUT</sub>	
V <sub>IL</sub>	Low-level digital input voltage at P <sub>WMON</sub>			0.4	V
	Low-level digital input voltage at V <sub>CTRL</sub>			0.4	
Operating free-air temperature range		–35		85	°C

**ELECTRICAL CHARACTERISTICS**T<sub>A</sub> = 25°C (unless otherwise noted)

PARAMETER		TEST CONDITIONS	MIN	TYP	MAX	UNIT
I <sub>CC1</sub>	Consumption current at VO_BT	V <sub>(VO_BT)</sub> : 3.6 V, VOUT: No load V <sub>(PWMON)</sub> : AGND (PFM mode)		60	100	μA
I <sub>CC2</sub>	Consumption current at VO_BT	V <sub>(VO_BT)</sub> : 5 V, VOUT: No load V <sub>(PWMON)</sub> : VOUT (PWM mode)		250	350	μA
I <sub>CC3</sub>	Consumption current at VBK	V <sub>(VO_BT)</sub> : 3.6 V, V <sub>(VBK)</sub> : 3 V VOUT: No load		0.1	1	μA
I <sub>CC4</sub>	Consumption current at VBK	VO_BT: Open, V <sub>(VBK)</sub> : 3 V VOUT: No load, V <sub>(V_CTRL)</sub> : VOUT		2.5	5	μA
I <sub>CC5</sub>	Consumption current at VBK	VO_BT: Open, V <sub>(VBK)</sub> : 3 V VOUT: No load, V <sub>(V_CTRL)</sub> : AGND		1.2	3	μA
I <sub>CC6</sub>	Consumption current at VBAT	V <sub>(VBAT)</sub> : 3.6 V, V <sub>(VO_BT)</sub> : 3.5 V		5	10	μA
I <sub>(SINK_CS)</sub>	Sink current at CS	V <sub>(CS)</sub> : 0.5 V, CS pin: Low-Z	1	1.5		mA
I <sub>(LEAK_CS)</sub>	Leakage current at CS	V <sub>(CS)</sub> : 5.5 V, CS pin: Hi-Z			1	μA
I <sub>(SINK_XRESET)</sub>	Sink current at XRESET	V <sub>(XRESET)</sub> : 0.5 V, XRESET pin: Low-Z	1	1.5		mA
I <sub>(LEAK_XRESET)</sub>	Leak current at XRESET	V <sub>(XRESET)</sub> : 5.5 V, XRESET pin: Hi-Z			1	μA
I <sub>(LEAK_VBK)</sub>	Leak current at VBK	V <sub>(VO_BT)</sub> : 5.5 V, V <sub>(VBK)</sub> : 0 V			1	μA
V <sub>(UVLO_DET)</sub>	UVLO/CS detection level at VBAT	V <sub>(VBAT)</sub> : from 0 V to 5.5 V	2.50	2.70	2.90	V
V <sub>(UVLO_HYS)</sub>	UVLO/CS hysteresis at VBAT	V <sub>(VBAT)</sub> : from 5.5 V to 0 V	–250	–200	–150	mV
V <sub>(CS_DET)</sub>	CS detection level at VO_BT	V <sub>(VO_BT)</sub> : from 5 V to 0 V	3.071	3.150	3.229	V
V <sub>(CS_HYS)</sub>	CS hysteresis at VO_BT	V <sub>(VO_BT)</sub> : from 0 V to 5 V	50	100	150	mV
V <sub>(XRESET_DET)</sub>	XRESET detection level	V <sub>(VOUT)</sub> : from 3.3 V to 0 V	2.048	2.100	2.153	V
V <sub>(XRESET_HYS)</sub>	XRESET hysteresis	V <sub>(VOUT)</sub> : from 0 V to 3.3 V	50	100	150	mV
V <sub>(SW1)</sub>	Change the power path for VOUT	Monitoring at VO_BT	2.94	3.00	3.06	V
V <sub>(SW2)</sub>	CS output disable level	Monitoring at VOUT	3.072	3.135	3.198	V
V <sub>(WAKE_DET)</sub>	Threshold of WAKE mode	V <sub>(VO_BT)</sub> : from 0 V to 3.6 V	2.38	2.50	2.63	V
V <sub>(WAKE_HYS)</sub>	WAKE mode hysteresis	V <sub>(VO_BT)</sub> : from 3.6 V to 0 V	–150	–100	–50	mV
R <sub>(ON_VBK)</sub>	On resistance between VBK and VOUT	VO_BT: Open, V <sub>(VBK)</sub> : 3 V, I <sub>(VOUT)</sub> : 2 mA		30	60	Ω
TSD <sup>(1)</sup>	Thermal shutdown detection temperature			150		°C

(1) Specified by design. Not production tested.

**ELECTRICAL CHARACTERISTICS (continued)**
 $T_A = 25^\circ\text{C}$  (unless otherwise noted)

PARAMETER		TEST CONDITIONS	MIN	TYP	MAX	UNIT
<b>Boost DC/DC Converter</b>						
$V_{(FB)}$	Reference voltage	$V_{(PWMON)}$ : AGND (PFM mode)	1.213	1.250	1.288	V
		$V_{(PWMON)}$ : VOUT (PWM mode)	1.225	1.250	1.275	
	Overvoltage protection threshold	Monitoring at FB	1.30	1.35	1.40	V
	Overcurrent protection threshold	$V_{(PWMON)}$ : AGND (PFM mode)	0.48	0.60	0.72	A
		$V_{(PWMON)}$ : VOUT (PWM mode)	0.8	1.0	1.2	
OSC	Internal OSC frequency	$V_{(PWMON)}$ : VOUT (PWM mode)	675	750	825	kHz
$R_{(ON\_P)}$	P-ch FET ON resistance	$V_{(VO\_BT)}$ : 5 V		500	700	m $\Omega$
$R_{(ON\_N)}$	N-ch FET ON resistance	$V_{(VO\_BT)}$ : 5 V		200	250	m $\Omega$
$R_{(ON\_FBG)}$	FBG ON resistance	$V_{(PWMON)}$ : VOUT (PWM mode)		1	1.5	k $\Omega$
$I_{(LEAK\_FBG)}$	Leakage current at FBG	$V_{(PWMON)}$ : AGND (PFM mode)			1	$\mu\text{A}$
<b>3.3-V Output LDO (VOUT)</b>						
$V_{(VOUT)}$	Output voltage of VOUT	$V_{(VO\_BT)}$ : 5 V, $I_{(VOUT)}$ : 1 mA	3.234	3.300	3.366	V
$I_{(VOUT)}$	Output current of VOUT	$V_{(VO\_BT)}$ : 5 V, $V_{(VOUT)} \geq 3.156$ V			30	mA
	Overcurrent protection threshold			50		mA
<b>3.3-V Output LDO (VRO)</b>						
$V_{(VRO)}$	Output voltage of VRO	$V_{(VO\_BT)}$ : 5 V, $I_{(VRO)}$ : 1 mA	3.234	3.300	3.366	V
$I_{(VRO)}$	Output current of VRO	$V_{(VO\_BT)}$ : 5 V, $V_{(VRO)} \geq 3.156$ V		10	30	mA
	Overcurrent protection threshold			50		mA
<b>1.8-V Output LDO (VO1R8)</b>						
$V_{(VO1R8)}$	Output voltage of VO1R8	$V_{(V\_CTRL)}$ : VOUT, $V_{(VO\_BT)}$ : 5 V, $I_{(VO1R8)}$ : 100 $\mu\text{A}$	1.71	1.80	1.89	V
$I_{(VO1R8)}$	Output current of VO1R8	$V_{(V\_CTRL)}$ : VOUT			100	$\mu\text{A}$
<b>1.2-V Output LDO (VO1R2)</b>						
$V_{(VO1R2)}$	Output voltage of VO1R2	$V_{(V\_CTRL)}$ : VOUT, $V_{(VO\_BT)}$ : 5 V, $I_{(VO1R2)}$ : 100 $\mu\text{A}$	1.1	1.2	1.3	V
$I_{(VO1R2)}$	Output current of VO1R2	$V_{(V\_CTRL)}$ : VOUT			100	$\mu\text{A}$

**SWITCHING CHARACTERISTICS**
 $T_A = 25^\circ\text{C}$  (unless otherwise noted)

PARAMETER		TEST CONDITIONS	MIN	TYP	MAX	UNIT
$T_{CS}^{(1)}$	Detection delay at CS	$V_{(VO\_BT)}$ : from 3.6 V to 2.0 V		55		$\mu\text{s}$
$T_{XRESET}^{(1)}$	Detection delay at XRESET	$V_{(VOUT)}$ : from 1.5 V to 3.0 V		25		$\mu\text{s}$

(1) Specified by design. Not production tested.

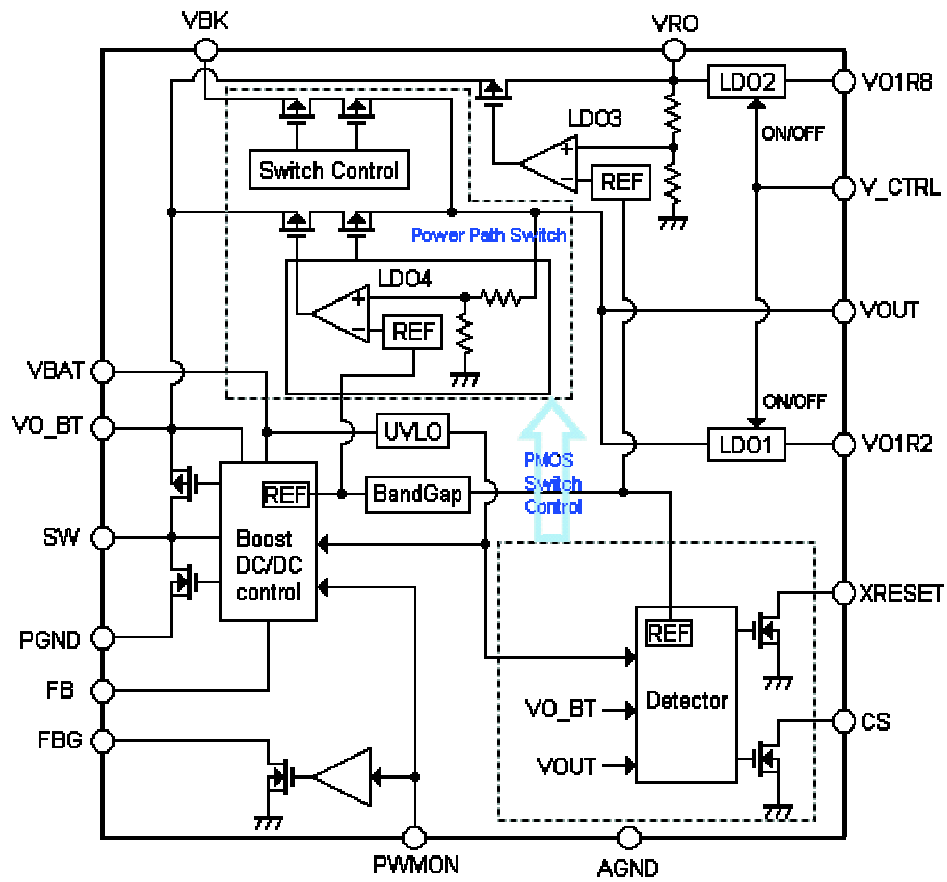
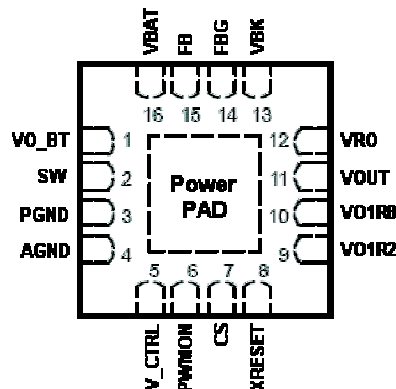

Figure 3. Block Diagram

**PIN ASSIGNMENTS**

**TERMINAL FUNCTIONS**

TERMINAL		I/O <sup>(1)</sup>	DESCRIPTION
NO.	NAME		
1	VO_BT	O	Boost converter output. This voltage is defined by the ration of external resistors. Please see the description in detail.
2	SW	I	Switching terminal for boost converter. This terminal should be connected to the external inductor.
3	PGND	G	Power ground. Connect to the ground plane.
4	AGND	G	Analog ground. Connect to the ground lane.
5	V_CTRL	I	LDO Enable/Disable input. When the input level is Low, it disables the operation of LDOs regarding VO1R8 and VO1R2. When the input level is high, it enables the operation of LDOs regarding VO1R8 and VO1R2.
6	PWMON	I	Modulation select pin. When the input level is low, the boost converter operates as PFM mode. When the input level is high, the boost converter operates as PWM mode.
7	CS	O	Indicator which monitors VBAT pin and VO_BT pin. CS is an open-drain output that goes low when the voltage level of VO_BT pin or VBAT pin is lower than the threshold. The threshold is specified with the Electrical Characteristics.
8	XRESET	O	Indicator that monitors VOUT; the output of 3.3-V LDO or backup battery. XRESET is an open-drain output that goes low when the voltage level of VOUT is lower than the threshold. The threshold is specified with the Electrical Characteristics.
9	VO1R2	O	1.2-V output regulated by LDO. The voltage level sets 1.2 V internally.
10	VO1R8	O	1.8-V output regulated by LDO. The voltage level sets 1.8 V internally.
11	VOUT	O	3.3-V output regulated by LDO or the voltage from backup battery. This output is selected by internal power switch. The selection depends on the output voltage of boost converter.
12	VRO	O	3.3-V output regulated by LDO. The voltage level sets 3.3 V internally.
13	VBK	I	Backup battery input. The recommended input voltage at VBK is from 1.8V to 5.5V.
14	FBG	I	Boost converter output adjustable pin. When the level of PWMON pin is low, the impedance of FBG is high impedance. When the level of PWMON pin is high, the impedance of FBG is almost GND level.
15	FB	I	Feedback voltage from boost converter output.
16	VBAT	I	Power supply from main battery. The recommended input voltage at VBAT is from 2.65V to 5.5V.

(1) I: Input pin, O: Output pin, P: Power supply pin, G: GND pin

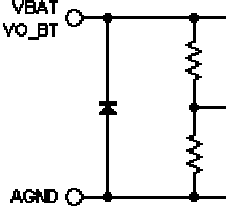
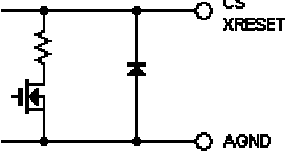
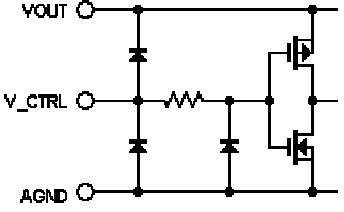
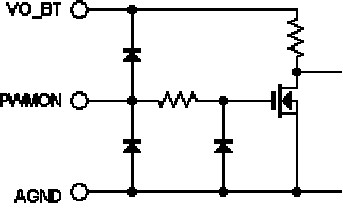
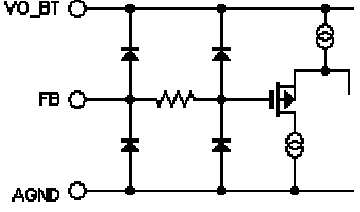
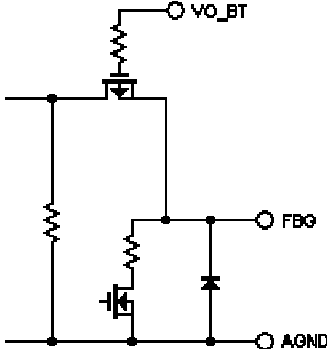
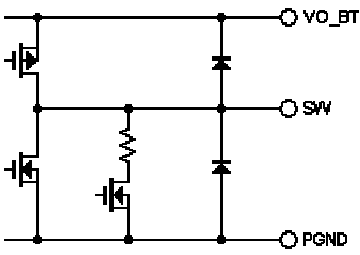
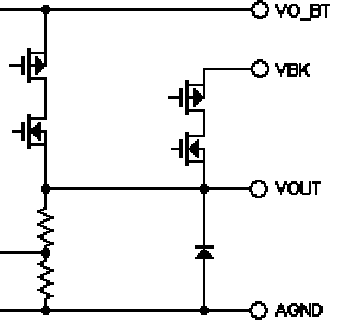
I/O Equivalent Circuits

<p style="text-align: center;"><b>VBAT/VO_BT</b></p> 	<p style="text-align: center;"><b>CS/XRESET</b></p> 
<p style="text-align: center;"><b>V_CTRL</b></p> 	<p style="text-align: center;"><b>PWMON</b></p> 
<p style="text-align: center;"><b>FB</b></p> 	<p style="text-align: center;"><b>FBG</b></p> 
<p style="text-align: center;"><b>SW</b></p> 	<p style="text-align: center;"><b>VOUT</b></p> 



I/O Equivalent Circuits (continued)

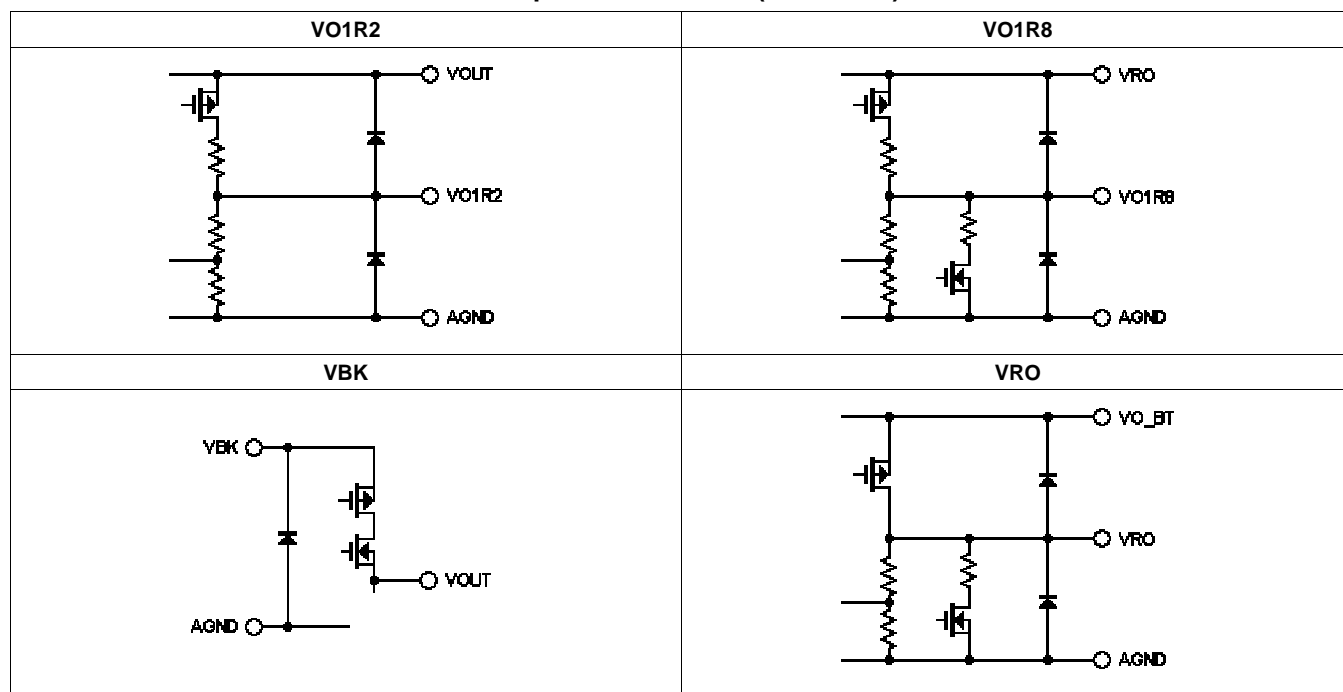

Figure 4. I/O Equivalent Circuits

## FUNCTIONAL DESCRIPTION

### Power-Path Switch

The TPS65510 has the switch to select a power path of VOUT pin from main battery or backup battery. These switches consist of P-ch MOSFET. Also, these switches avoid the reverse current from output side to battery side.

When the voltage of VO\_BT pin (output of boost converter) is higher than the threshold specified by  $V_{(SW1)}$  in Electrical Characteristics, the power path of VOUT comes from main battery via internal boost converter. The voltage of VOUT pin sets 3.3 V with internal LDO.

When a voltage of VO\_BT pin is lower than the threshold specified by  $V_{(SW1)}$  in Electrical Characteristics, the power path of VOUT comes from backup battery at VBK pin. Before the voltage of VO\_BT pin reaches  $V_{(SW1)}$ , the switch to select a power path cannot change the power path route.

The voltage coming from backup battery is not regulated internally. When the voltage of VOUT is lower than the threshold specified by  $V_{(XRESET\_DET)}$  and  $V_{(XRESET\_HYS)}$  in Electrical Characteristics, the voltage of XRESET pin goes low (see the description of STATUS INDICATORS).

At the start of boost converter operation, the power path is different to avoid the power supply from backup battery. In this situation, the power path of VOUT comes from main battery via internal boost converter even if the output voltage of VO\_BT is lower than threshold for CS signal specified by  $V_{(SW1)}$  in Electrical Characteristics.

### Boost Converter

The TPS65510 has the boost converter, and the power path comes from the main battery. It has four operation modes, WAKE mode, Pulse Frequency Modulation (PFM) mode, Pulse Width Modulation (PWM) mode and THROUGH mode.

At first, this converter operates as WAKE mode until the voltage of VO\_BT pin is less than the threshold specified by  $V_{(WAKE\_DET)}$  and  $V_{(WAKE\_HYS)}$  in Electrical Characteristics. The switching frequency of WAKE mode is fixed. Only N-ch MOSFET operates during WAKE mode until the voltage of VO\_BT pin reaches the threshold specified by  $V_{(WAKE\_DET)}$  and  $V_{(WAKE\_HYS)}$  in Electrical Characteristics.

After the voltage of VO\_BT pin reaching more than the threshold specified by  $V_{(WAKE\_DET)}$  and  $V_{(WAKE\_HYS)}$  in Electrical Characteristics, the operation mode is shifted from WAKE mode to other modes selected by the level of PWMON pin. When the voltage of PWMON pin is low level, the boost converter operates as PFM mode. When the voltage of PWMON pin is high level, the boost converter operates as PWM mode. When the voltage of main battery is higher than the voltage of VO\_BT pin, the converter operates as THROUGH mode to reduce the consumption current at VO\_BT pin. At this mode, The TPS65510 forces P-ch MOSFET to be ON and N-ch MOSFET to be OFF. It means that the voltage of VO\_BT pin is not regulated.

The boost converter has the reversed current protection to monitor the different voltage between VO\_BT pin and SW pin. The protection monitors the difference at both PFM mode and PWM mode. When the voltage of SW pin is larger than that of VO\_BT pin, the protection is activated. When the protection is activated, the internal P-ch MOSFET turns OFF. This means that the voltage of SW pin converges the battery voltage naturally.

The output voltage of boost converter depends on the operation mode. When the boost converter operates as PFM mode, the impedance of FBG pin goes Hi-Z and the output voltage is defined by R1, R2 and R3 shown in [Figure 1](#) and [Figure 2](#). When the boost converter operates as PWM mode, the impedance of FBG pin goes almost zero and the output voltage is defined by R1 and R2 shown in [Figure 1](#) and [Figure 2](#). The output voltage is calculated by [Equation 1](#) and [Equation 2](#).

PFM mode:

$$V_{VO\_BT} = \left( 1 + \frac{R_1}{R_2 + R_3} \right) \cdot V_{FB} \quad (1)$$

PWM mode:

$$V_{VO\_BT} = \left( 1 + \frac{R_1}{R_2} \right) \cdot V_{FB} \quad (2)$$

Where:

$V_{VO\_BT}$ : Voltage of VO\_BT pin

$V_{FB}$ : Voltage of FB  
pin defined by  
reference voltage in  
Electrical  
Characteristics

## LDO Voltage Regulators

The TPS65510 has four types of LDO voltage regulators; 1.2-V output (LDO1, shown in [Figure 3](#)), 1.8-V output (LDO2, shown in [Figure 3](#)) and 3.3-V dual output (LDO3 and LDO4, shown in [Figure 3](#)). These output voltage are set by internal feedback loop only. The device has enable/disable control pin named V\_CTRL for LDO1 and LDO2. When the voltage of V\_CTRL is low level, the device disables the output of LDO1 and LDO2. When the voltage of V\_CTRL is high level, the device enables the output of LDO1 and LDO2.

The power paths of LDO2, LDO3, and LDO4 are fixed; from output of LDO3 for LDO2 and from output of boost converter for LDO3 and LDO4. The power path of LDO1 is selected by power path switch; when output voltage of the boost converter is higher than the threshold specified by  $V_{(SW1)}$  in Electrical Characteristics, the path comes from output of LDO4. When output voltage of the boost converter is lower than the threshold specified by  $V_{(SW1)}$  in Electrical Characteristics, the path comes from backup battery connected to VBK pin.

The maximum outputs current are specified by  $I_{(VO1R2)}$ ,  $I_{(VO1R8)}$ ,  $I_{(VRO)}$  and  $I_{(VOUT)}$  in Electrical Characteristics.

## Status Indicators

The TPS65510 has two device status indicators; CS and XRESET. These signal pins consist of open drain of N-ch MOSFET. Due to this, the pullup resistors should be needed. The recommended values of pullup resistors are 100 kΩ.

CS function monitors the voltage level of VBAT pin and VO\_BT pin for selecting power path of VOUT. When the signal level of CS pin is high level, the power path of VOUT comes from the main battery via the boost converter. When the signal level of CS pin is low level, it comes from backup battery except the starting operation of boost converter. When the boost converter starts operation with the main battery, the P-ch MOSFET at LDO4 turns ON to avoid supplying the power from backup battery even if the voltage of VOUT is lower than the threshold specified by  $V_{(SW1)}$  in Electrical Characteristics. The signal of the CS pin remains low level when the main battery is removed (including the transition) or the voltage level of VOUT does not achieve the threshold specified by  $V_{(SW2)}$  in Electrical Characteristics.

XRESET function monitors the voltage level of VOUT pin for resetting the load like RTC. When the voltage of VOUT is more than the threshold specified by  $V_{(XRESET\_DET)}$  and  $V_{(XRESET\_HYS)}$  in Electrical Characteristics, the signal level of XRESET pin is high. When the voltage of VOUT is less than the threshold specified by  $V_{(XRESET\_DET)}$  and  $V_{(XRESET\_HYS)}$  in Electrical Characteristics, the signal level of XRESET pin is low. This situation requires resetting the load. The detailed waveform is shown in [Figure 5](#).

### Summary of Status Indicator and Power-Path Switch

	Description	
CS <sup>(1)</sup>	Detection	Voltage of VO_BT pin
	Detect level	$V_{(CS\_DET)}$ and $V_{(CS\_HYS)}$ in Electrical Characteristics
Disable CS signal	Detection	Voltage of VOUT pin
	Detect level	$V_{(SW2)}$ in Electrical Characteristics
XRESET	Detection	Voltage of VOUT pin
	Detect level	$V_{(XRESET\_DET)}$ and $V_{(XRESET\_HYS)}$ in Electrical Characteristics
Power SW <sup>(2)</sup>	Detection of path change	Voltage of VO_BT pin
	Detect level	$V_{(SW1)}$ in Electrical Characteristics

- (1) When the voltage of VBAT pin is less than the threshold of UVLO, the output of CS pin forces low level.
- (2) The Power path switch changes the path after the voltage of VO\_BT is higher than  $V_{(CS\_DET)}$ . Before that, the power path of VOUT comes from VO\_BT pin; not VBK pin.

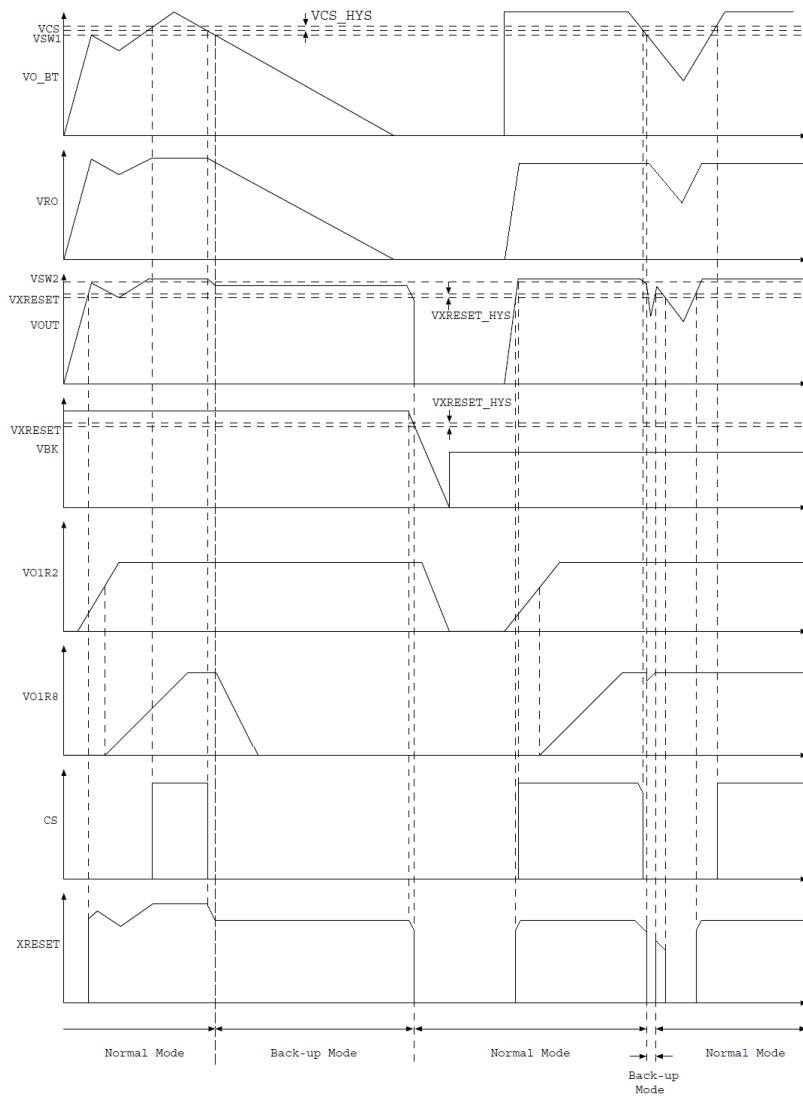

Figure 5. Power-Path Switch Timing Chart

**Protection**

The TPS65510 has over current protection (OCP), over voltage protection (OVP) Thermal shutdown (TSD) and Under Voltage Lock Out (UVLO). See [Table 1](#).

**Table 1. Conditions of Protections**

PIN	PROTECTION	CONDITION	
SW	OVP	Detect condition	Voltage of FB pin is greater than the threshold.
		Change mode	Operation disable without latch off
		Recovery condition	Voltage of FB pin is less than the threshold (auto recovery).
	OCP	Detect condition	Current of SW pin is greater than the threshold with counting 64 cycles × 750 [kHz] and the output voltage of VO_BT is less than 85% compared with the target voltage.
		Change mode	Operation mode changes from PWM mode to PFM mode.
		Recovery condition	Current of SW pin is less than the threshold and input edge signal from low level to high level at the PWMON pin.
VOUT	OCP	Detect condition	Current of VOUT pin is greater than the threshold.
		Change mode	Operation disable without latch off
		Recovery condition	Current of VOUT pin is less than the threshold (auto recovery).
VRO	OCP	Detect condition	Current of VRO pin is greater than the threshold.
		Change mode	Operation disable without latch off
		Recovery condition	Current of VRO pin is less than the threshold (auto recovery).
-	TSD	Detect condition	Temperature of chip is greater than the threshold.
		Change mode	Operation of boost converter shuts down with latch off.
		Recovery condition	Temperature of chip is lower than the threshold. Connect the main battery after disconnecting the main battery from the system
VBAT	UVLO	Detect condition	Voltage of VBAT pin is less than the threshold.
		Change mode	Operation of boost converter shutdown without latch off
		Recovery condition	Connect the main battery after disconnecting the main battery from the system.

**PACKAGING INFORMATION**

Orderable Device	Status <sup>(1)</sup>	Package Type	Package Drawing	Pins	Package Qty	Eco Plan <sup>(2)</sup>	Lead/Ball Finish	MSL Peak Temp <sup>(3)</sup>
TPS65510RGTR	ACTIVE	QFN	RGT	16	3000	Green (RoHS & no Sb/Br)	Call TI	Level-2-260C-1 YEAR
TPS65510RGTRG4	ACTIVE	QFN	RGT	16	3000	Green (RoHS & no Sb/Br)	Call TI	Level-2-260C-1 YEAR
TPS65510RGTT	ACTIVE	QFN	RGT	16	250	Green (RoHS & no Sb/Br)	Call TI	Level-2-260C-1 YEAR
TPS65510RGTTG4	ACTIVE	QFN	RGT	16	250	Green (RoHS & no Sb/Br)	Call TI	Level-2-260C-1 YEAR

<sup>(1)</sup> The marketing status values are defined as follows:

**ACTIVE:** Product device recommended for new designs.

**LIFEBUY:** TI has announced that the device will be discontinued, and a lifetime-buy period is in effect.

**NRND:** Not recommended for new designs. Device is in production to support existing customers, but TI does not recommend using this part in a new design.

**PREVIEW:** Device has been announced but is not in production. Samples may or may not be available.

**OBSOLETE:** TI has discontinued the production of the device.

<sup>(2)</sup> Eco Plan - The planned eco-friendly classification: Pb-Free (RoHS), Pb-Free (RoHS Exempt), or Green (RoHS & no Sb/Br) - please check <http://www.ti.com/productcontent> for the latest availability information and additional product content details.

**TBD:** The Pb-Free/Green conversion plan has not been defined.

**Pb-Free (RoHS):** TI's terms "Lead-Free" or "Pb-Free" mean semiconductor products that are compatible with the current RoHS requirements for all 6 substances, including the requirement that lead not exceed 0.1% by weight in homogeneous materials. Where designed to be soldered at high temperatures, TI Pb-Free products are suitable for use in specified lead-free processes.

**Pb-Free (RoHS Exempt):** This component has a RoHS exemption for either 1) lead-based flip-chip solder bumps used between the die and package, or 2) lead-based die adhesive used between the die and leadframe. The component is otherwise considered Pb-Free (RoHS compatible) as defined above.

**Green (RoHS & no Sb/Br):** TI defines "Green" to mean Pb-Free (RoHS compatible), and free of Bromine (Br) and Antimony (Sb) based flame retardants (Br or Sb do not exceed 0.1% by weight in homogeneous material)

<sup>(3)</sup> MSL, Peak Temp. -- The Moisture Sensitivity Level rating according to the JEDEC industry standard classifications, and peak solder temperature.

**Important Information and Disclaimer:**The information provided on this page represents TI's knowledge and belief as of the date that it is provided. TI bases its knowledge and belief on information provided by third parties, and makes no representation or warranty as to the accuracy of such information. Efforts are underway to better integrate information from third parties. TI has taken and continues to take reasonable steps to provide representative and accurate information but may not have conducted destructive testing or chemical analysis on incoming materials and chemicals. TI and TI suppliers consider certain information to be proprietary, and thus CAS numbers and other limited information may not be available for release.

In no event shall TI's liability arising out of such information exceed the total purchase price of the TI part(s) at issue in this document sold by TI to Customer on an annual basis.

**TAPE AND REEL INFORMATION**

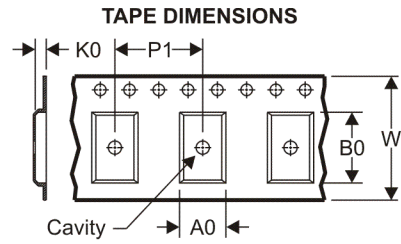
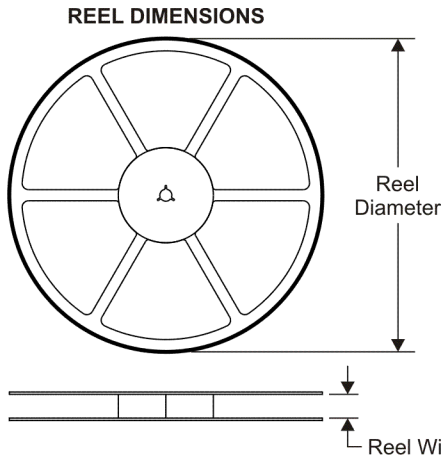

A0	Dimension designed to accommodate the component width
B0	Dimension designed to accommodate the component length
K0	Dimension designed to accommodate the component thickness
W	Overall width of the carrier tape
P1	Pitch between successive cavity centers

**QUADRANT ASSIGNMENTS FOR PIN 1 ORIENTATION IN TAPE**

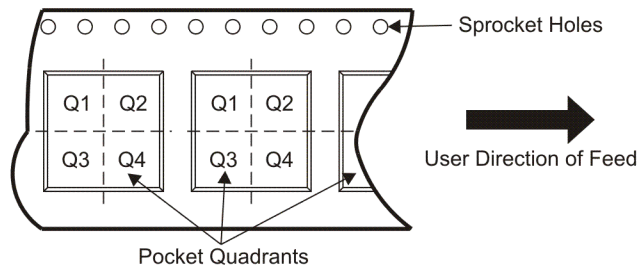

\*All dimensions are nominal

Device	Package Type	Package Drawing	Pins	SPQ	Reel Diameter (mm)	Reel Width W1 (mm)	A0 (mm)	B0 (mm)	K0 (mm)	P1 (mm)	W (mm)	Pin1 Quadrant
TPS65510RGTR	QFN	RGT	16	3000	330.0	12.4	3.3	3.3	1.1	8.0	12.0	Q2
TPS65510RGTT	QFN	RGT	16	250	180.0	12.4	3.3	3.3	1.1	8.0	12.0	Q2



**TAPE AND REEL BOX DIMENSIONS**



\*All dimensions are nominal

Device	Package Type	Package Drawing	Pins	SPQ	Length (mm)	Width (mm)	Height (mm)
TPS65510RGTR	QFN	RGT	16	3000	346.0	346.0	29.0
TPS65510RGTT	QFN	RGT	16	250	190.5	212.7	31.8

[查询"TPS65510"供应商](#)

RGT (S-PVQFN-N16)

PLASTIC QUAD FLATPACK NO-LEAD

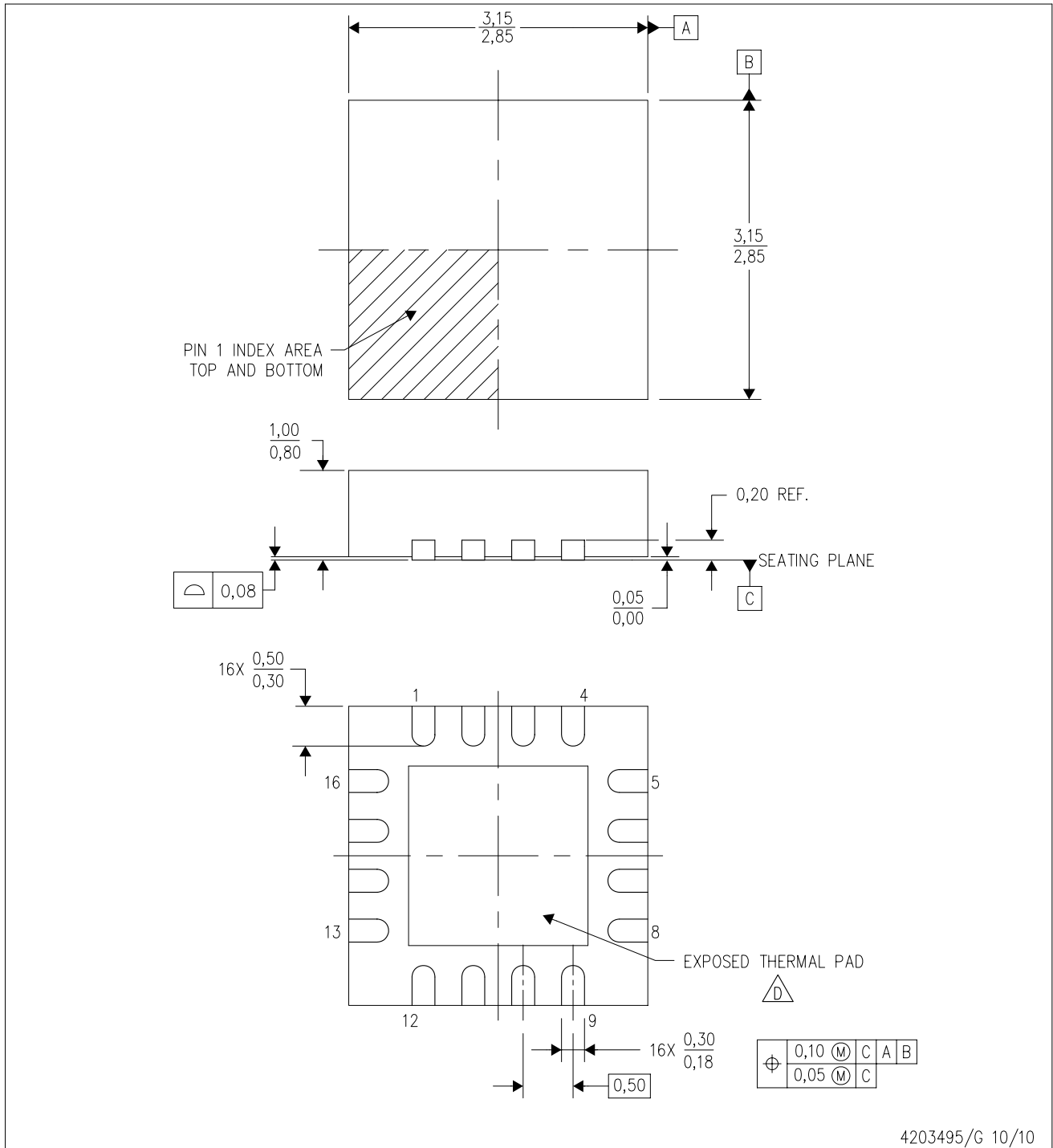

4203495/G 10/10

- NOTES:
- A. All linear dimensions are in millimeters. Dimensioning and tolerancing per ASME Y14.5M-1994.
  - B. This drawing is subject to change without notice.
  - C. Quad Flatpack, No-leads (QFN) package configuration.
  - D. The package thermal pad must be soldered to the board for thermal and mechanical performance. See the Product Data Sheet for details regarding the exposed thermal pad dimensions.
  - E. Falls within JEDEC MO-220.

RGT (S-PVQFN-N16)

PLASTIC QUAD FLATPACK NO-LEAD

**THERMAL INFORMATION**

This package incorporates an exposed thermal pad that is designed to be attached directly to an external heatsink. The thermal pad must be soldered directly to the printed circuit board (PCB). After soldering, the PCB can be used as a heatsink. In addition, through the use of thermal vias, the thermal pad can be attached directly to the appropriate copper plane shown in the electrical schematic for the device, or alternatively, can be attached to a special heatsink structure designed into the PCB. This design optimizes the heat transfer from the integrated circuit (IC).

For information on the Quad Flatpack No-Lead (QFN) package and its advantages, refer to Application Report, QFN/SON PCB Attachment, Texas Instruments Literature No. SLUA271. This document is available at [www.ti.com](http://www.ti.com).

The exposed thermal pad dimensions for this package are shown in the following illustration.

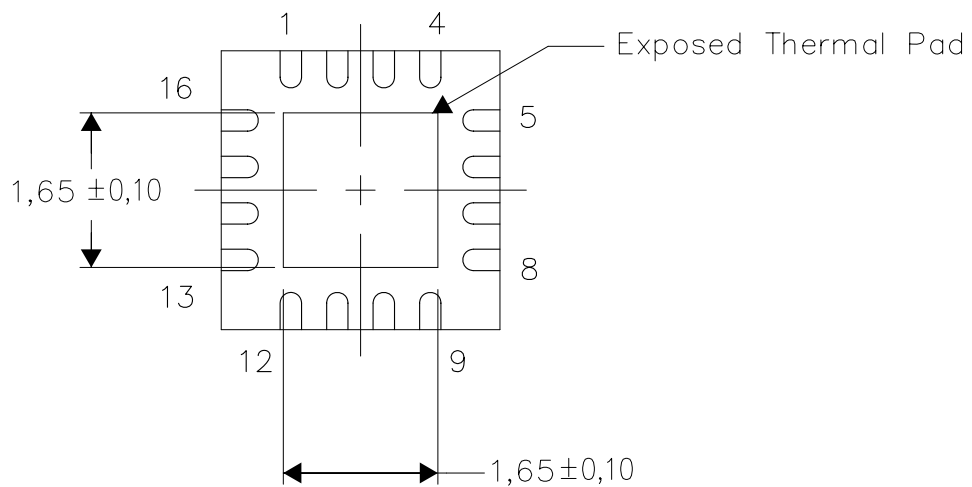

Bottom View

Exposed Thermal Pad Dimensions

4206349-7/0 11/10

NOTE: A. All linear dimensions are in millimeters

## IMPORTANT NOTICE

Texas Instruments Incorporated and its subsidiaries (TI) reserve the right to make corrections, modifications, enhancements, improvements, and other changes to its products and services at any time and to discontinue any product or service without notice. Customers should obtain the latest relevant information before placing orders and should verify that such information is current and complete. All products are sold subject to TI's terms and conditions of sale supplied at the time of order acknowledgment.

TI warrants performance of its hardware products to the specifications applicable at the time of sale in accordance with TI's standard warranty. Testing and other quality control techniques are used to the extent TI deems necessary to support this warranty. Except where mandated by government requirements, testing of all parameters of each product is not necessarily performed.

TI assumes no liability for applications assistance or customer product design. Customers are responsible for their products and applications using TI components. To minimize the risks associated with customer products and applications, customers should provide adequate design and operating safeguards.

TI does not warrant or represent that any license, either express or implied, is granted under any TI patent right, copyright, mask work right, or other TI intellectual property right relating to any combination, machine, or process in which TI products or services are used. Information published by TI regarding third-party products or services does not constitute a license from TI to use such products or services or a warranty or endorsement thereof. Use of such information may require a license from a third party under the patents or other intellectual property of the third party, or a license from TI under the patents or other intellectual property of TI.

Reproduction of TI information in TI data books or data sheets is permissible only if reproduction is without alteration and is accompanied by all associated warranties, conditions, limitations, and notices. Reproduction of this information with alteration is an unfair and deceptive business practice. TI is not responsible or liable for such altered documentation. Information of third parties may be subject to additional restrictions.

Resale of TI products or services with statements different from or beyond the parameters stated by TI for that product or service voids all express and any implied warranties for the associated TI product or service and is an unfair and deceptive business practice. TI is not responsible or liable for any such statements.

TI products are not authorized for use in safety-critical applications (such as life support) where a failure of the TI product would reasonably be expected to cause severe personal injury or death, unless officers of the parties have executed an agreement specifically governing such use. Buyers represent that they have all necessary expertise in the safety and regulatory ramifications of their applications, and acknowledge and agree that they are solely responsible for all legal, regulatory and safety-related requirements concerning their products and any use of TI products in such safety-critical applications, notwithstanding any applications-related information or support that may be provided by TI. Further, Buyers must fully indemnify TI and its representatives against any damages arising out of the use of TI products in such safety-critical applications.

TI products are neither designed nor intended for use in military/aerospace applications or environments unless the TI products are specifically designated by TI as military-grade or "enhanced plastic." Only products designated by TI as military-grade meet military specifications. Buyers acknowledge and agree that any such use of TI products which TI has not designated as military-grade is solely at the Buyer's risk, and that they are solely responsible for compliance with all legal and regulatory requirements in connection with such use.

TI products are neither designed nor intended for use in automotive applications or environments unless the specific TI products are designated by TI as compliant with ISO/TS 16949 requirements. Buyers acknowledge and agree that, if they use any non-designated products in automotive applications, TI will not be responsible for any failure to meet such requirements.

Following are URLs where you can obtain information on other Texas Instruments products and application solutions:

<b>Products</b>		<b>Applications</b>	
Amplifiers	<a href="http://amplifier.ti.com">amplifier.ti.com</a>	Audio	<a href="http://www.ti.com/audio">www.ti.com/audio</a>
Data Converters	<a href="http://dataconverter.ti.com">dataconverter.ti.com</a>	Automotive	<a href="http://www.ti.com/automotive">www.ti.com/automotive</a>
DLP® Products	<a href="http://www.dlp.com">www.dlp.com</a>	Communications and Telecom	<a href="http://www.ti.com/communications">www.ti.com/communications</a>
DSP	<a href="http://dsp.ti.com">dsp.ti.com</a>	Computers and Peripherals	<a href="http://www.ti.com/computers">www.ti.com/computers</a>
Clocks and Timers	<a href="http://www.ti.com/clocks">www.ti.com/clocks</a>	Consumer Electronics	<a href="http://www.ti.com/consumer-apps">www.ti.com/consumer-apps</a>
Interface	<a href="http://interface.ti.com">interface.ti.com</a>	Energy	<a href="http://www.ti.com/energy">www.ti.com/energy</a>
Logic	<a href="http://logic.ti.com">logic.ti.com</a>	Industrial	<a href="http://www.ti.com/industrial">www.ti.com/industrial</a>
Power Mgmt	<a href="http://power.ti.com">power.ti.com</a>	Medical	<a href="http://www.ti.com/medical">www.ti.com/medical</a>
Microcontrollers	<a href="http://microcontroller.ti.com">microcontroller.ti.com</a>	Security	<a href="http://www.ti.com/security">www.ti.com/security</a>
RFID	<a href="http://www.ti-rfid.com">www.ti-rfid.com</a>	Space, Avionics & Defense	<a href="http://www.ti.com/space-avionics-defense">www.ti.com/space-avionics-defense</a>
RF/IF and ZigBee® Solutions	<a href="http://www.ti.com/lprf">www.ti.com/lprf</a>	Video and Imaging	<a href="http://www.ti.com/video">www.ti.com/video</a>
		Wireless	<a href="http://www.ti.com/wireless-apps">www.ti.com/wireless-apps</a>