

## LMH6554

### 2.8 GHz Ultra Linear Fully Differential Amplifier

#### General Description

The LMH6554 is a high performance fully differential amplifier designed to provide the exceptional signal fidelity and wide large-signal bandwidth necessary for driving 8 to 16 bit high speed data acquisition systems. Using National's proprietary differential current mode input stage architecture, the LMH6554 has unity gain, small-signal bandwidth of 2.8 GHz and allows operation at gains greater than unity without sacrificing response flatness, bandwidth, harmonic distortion, or output noise performance.

The device's low impedance differential output is designed to drive ADC inputs and any intermediate filter stage. The LMH6554 delivers 16-bit linearity up to 75 MHz when driving 2V peak-to-peak into loads as low as 200Ω.

The LMH6554 is fabricated in National Semiconductor's advanced complementary BiCMOS process and is available in a space saving, thermally enhanced 14 lead LLP package for higher performance.

#### Features

■ Small signal bandwidth	2.8 GHz
■ 2 V <sub>PP</sub> large signal bandwidth	1.8 GHz
■ 0.1 dB Gain flatness	830 MHz
■ OIP3 @ 150 MHz	47 dBm
■ HD2/HD3 @ 75 MHz	-96 / -97 dBc
■ Input noise voltage	0.9 nV/√Hz
■ Input noise current	11 pA/√Hz
■ Slew rate	6200 V/μs
■ Power	260mW
■ Typical supply current	52 mA
■ Package	14 Lead LLP

#### Applications

- Differential ADC driver
- Single-ended to differential converter
- High speed differential signaling
- IF/RF and baseband gain blocks
- SAW filter buffer/driver
- Oscilloscope Probes
- Automotive Safety Applications
- Video over twisted pair
- Differential line driver

#### Typical Application

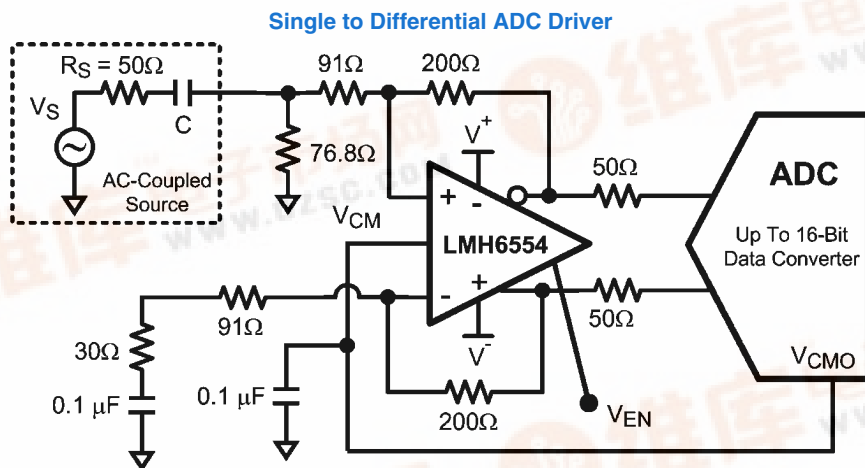

**Absolute Maximum Ratings** (Note 1)

查询"LMH6554"供应商

If Military/Aerospace specified devices are required, please contact the National Semiconductor Sales Office/Distributors for availability and specifications.

## ESD Tolerance (Note 5)

Human Body Model	2000V
Machine Model	250V
Charge Device Model	750V
Supply Voltage ( $V_S = V^+ - V^-$ )	5.5V
Common Mode Input Voltage	$\pm 1.25V$
Maximum Input Current	30mA
Maximum Output Current (pins 12, 13)	(Note 4)
Soldering Information	
Infrared or Convection (30 sec)	260°C

For soldering specifications

see product folder at [www.national.com](http://www.national.com) and  
[www.national.com/ms/MS/MS-SOLDERING.pdf](http://www.national.com/ms/MS/MS-SOLDERING.pdf)

**Operating Ratings** (Note 1)

Operating Temperature Range	-40°C to +125°C
Storage Temperature Range	-65°C to +150°C
Total Supply Voltage Temperature Range	4.7V to 5.25V

**Thermal Properties**

Junction-to-Ambient Thermal Resistance ( $\theta_{JA}$ )	60°C/W
Maximum Operating Junction Temperature	150°C

**+5V Electrical Characteristics** (Note 2)

Unless otherwise specified, all limits are guaranteed for  $T_A = +25^\circ\text{C}$ ,  $A_V = +2$ ,  $V^+ = +2.5V$ ,  $V^- = -2.5V$ ,  $R_L = 200\Omega$ ,  $V_{CM} = (V^+ + V^-)/2$ ,  $R_F = 200\Omega$ , for single-ended in, differential out. Boldface Limits apply at the temperature extremes.

Symbol	Parameter	Conditions	Min (Note 8)	Typ (Note 7)	Max (Note 8)	Units
<b>AC Performance (Differential)</b>						
SSBW	Small Signal -3 dB Bandwidth (Note 8)	$A_V = 1, V_{OUT} = 0.2 V_{PP}$		2800		MHz
		$A_V = 2, V_{OUT} = 0.2 V_{PP}$		2500		
		$A_V = 4, V_{OUT} = 0.2 V_{PP}$		1600		
LSBW	Large Signal Bandwidth	$A_V = 1, V_{OUT} = 2 V_{PP}$		1800		MHz
		$A_V = 2, V_{OUT} = 2 V_{PP}$		1500		
		$A_V = 2, V_{OUT} = 1.5 V_{PP}$		1900		
0.1 dBBW	0.1 dB Bandwidth	$A_V = 2, V_{OUT} = 0.2 V_{PP}, R_F = 250\Omega$		830		MHz
SR	Slew Rate	4V Step		6200		V/ $\mu\text{s}$
$t_r/t_f$	Rise/Fall Time	2V Step, 10-90%		290		ps
		0.4V Step, 10-90%		150		
$T_{s,0.1}$	0.1% Settling Time	2V Step, $R_L = 200\Omega$		4		ns
	Overdrive Recovery Time	$V_{IN} = 2V, A_V = 5 V/V$		6		ns
<b>Distortion and Noise Response</b>						
HD2	2 <sup>nd</sup> Harmonic Distortion	$V_{OUT} = 2 V_{PP}, f = 20 \text{ MHz}$		-102		dBc
		$V_{OUT} = 2 V_{PP}, f = 75 \text{ MHz}$		-96		
		$V_{OUT} = 2 V_{PP}, f = 125 \text{ MHz}$		-87		
		$V_{OUT} = 2 V_{PP}, f = 250 \text{ MHz}$		-79		
		$V_{OUT} = 1.5 V_{PP}, f = 250 \text{ MHz}$		-81		
HD3	3 <sup>rd</sup> Harmonic Distortion	$V_{OUT} = 2 V_{PP}, f = 20 \text{ MHz}$		-110		dBc
		$V_{OUT} = 2 V_{PP}, f = 75 \text{ MHz}$		-97		
		$V_{OUT} = 2 V_{PP}, f = 125 \text{ MHz}$		-87		
		$V_{OUT} = 2 V_{PP}, f = 250 \text{ MHz}$		-70		
		$V_{OUT} = 1.5 V_{PP}, f = 250 \text{ MHz}$		-75		
OIP3	Output 3rd-Order Intercept	$f = 150 \text{ MHz}, V_{OUT} = 2V_{PP}$ Composite		47		dBm
IMD3	Two-Tone Intermodulation	$f = 150 \text{ MHz}, V_{OUT} = 2V_{PP}$ Composite		-99		dBc
$e_n$	Input Voltage Noise Density	$f = 10 \text{ MHz}$		0.9		nV/ $\sqrt{\text{Hz}}$
$i_{n+}$	Input Noise Current	$f = 10 \text{ MHz}$		11		pA/ $\sqrt{\text{Hz}}$
$i_{n-}$	Input Noise Current	$f = 10 \text{ MHz}$		11		pA/ $\sqrt{\text{Hz}}$
NF	Noise Figure	50 $\Omega$ System, $A_V = 7, 10 \text{ MHz}$		8		dB

Symbol	Parameter	Conditions	Min (Note 8)	Typ (Note 7)	Max (Note 8)	Units
<b>Input Characteristics</b>						
$I_{BI+} / I_{BI-}$			-75	-29	20	$\mu\text{A}$
TCI <sub>bi</sub>	Input Bias Current Temperature Drift			8		$\mu\text{A}/^\circ\text{C}$
$I_{\text{BID}}$	Input Bias Current (Note 10)	$V_{\text{CM}} = 0\text{V}, V_{\text{ID}} = 0\text{V},$ $I_{\text{BOFFSET}} = (I_{\text{B-}} - I_{\text{B+}})/2$	-10	1	10	$\mu\text{A}$
TCI <sub>bo</sub>	Input Bias Current Diff Offset Temperature Drift (Note 7)			0.006		$\mu\text{A}/^\circ\text{C}$
CMRR	Common Mode Rejection Ratio	DC, $V_{\text{CM}} = 0\text{V}, V_{\text{ID}} = 0\text{V}$		83		dB
$R_{\text{IN}}$	Differential Input Resistance	Differential		19		$\Omega$
$C_{\text{IN}}$	Differential Input Capacitance	Differential		1		pF
CMVR	Input Common Mode Voltage Range	CMRR > 32 dB	$\pm 1.25$	$\pm 1.3$		V
<b>Output Performance</b>						
	Output Voltage Swing (Note 7)	Single-Ended Output	$\pm 1.35$	$\pm 1.42$		V
$I_{\text{OUT}}$	Output Current (Note 7)	$V_{\text{OUT}} = 0\text{V}$	$\pm 120$	$\pm 150$		mA
$I_{\text{SC}}$	Short Circuit Current	One Output Shorted to Ground $V_{\text{IN}} = 2\text{V}$ Single-Ended (Note 6)		150		mA
	Output Balance Error	$\Delta V_{\text{OUT}}$ Common Mode / $\Delta V_{\text{OUT}}$ Differential, $\Delta V_{\text{OD}} = 1\text{V}, f < 1\text{Mhz}$		-64		dB
<b>Output Common Mode Control Circuit</b>						
	Common Mode Small Signal Bandwidth	$V_{\text{IN+}} = V_{\text{IN-}} = 0\text{V}$		500		MHz
	Slew Rate	$V_{\text{IN+}} = V_{\text{IN-}} = 0\text{V}$		200		V/ $\mu\text{s}$
$V_{\text{OSCM}}$	Input Offset Voltage	Common Mode, $V_{\text{ID}} = 0, V_{\text{CM}} = 0\text{V}$	-16	-6.5	4	mV
$I_{\text{OSCM}}$	Input Offset Current	(Note 9)		6	18	$\mu\text{A}$
	Voltage Range		$\pm 1.18$	$\pm 1.25$		V
	CMRR	Measure $V_{\text{OD}}, V_{\text{ID}} = 0\text{V}$		82		dB
	Input Resistance			180		k $\Omega$
	Gain	$\Delta V_{\text{OCM}}/\Delta V_{\text{CM}}$	0.99	0.995	1.0	V/V
<b>Miscellaneous Performance</b>						
$Z_{\text{T}}$	Open Loop Transimpedance Gain	Differential		700		k $\Omega$
PSRR	Power Supply Rejection Ratio	DC, $\Delta V_{+} = \Delta V_{-} = 1\text{V}$	74	95		dB
$I_{\text{S}}$	Supply Current (Note 7)	$R_{\text{L}} = \infty$	46	52	57 60	mA
	Enable Voltage Threshold	Single 5V Supply		2.5		V
	Disable Voltage Threshold	Single 5V Supply		2.5		V
	Enable/Disable Time			15		ns
$I_{\text{SD}}$	Supply Current, Disabled	Enable=0, Single 5V supply	450	510	570 600	$\mu\text{A}$

**Note 1:** Absolute Maximum Ratings indicate limits beyond which damage to the device may occur. Operating Ratings indicate conditions for which the device is intended to be functional, but specific performance is not guaranteed. For guaranteed specifications, see the Electrical Characteristics tables.

**Note 2:** Electrical Table values apply only for factory testing conditions at the temperature indicated. Factory testing conditions result in very limited self-heating of the device such that  $T_J = T_A$ . No guarantee of parametric performance is indicated in the electrical tables under conditions of internal self-heating where  $T_J > T_A$ . See Applications Section for information on temperature de-rating of this device." Min/Max ratings are based on product characterization and simulation. Individual parameters are tested as noted.

**Note 3:** The maximum power dissipation is a function of  $T_{J(MAX)}$ ,  $\theta_{JA}$ . The maximum allowable power dissipation at any ambient temperature is  $P_D = (T_{J(MAX)} - T_A) / \theta_{JA}$ . All numbers apply for packages soldered directly onto a PC Board.

**Note 4:** The maximum output current ( $I_{OUT}$ ) is determined by device power dissipation limitations. See the Power Dissipation section of the Application Section for more details.

**Note 5:** Human Body Model, applicable std. MIL-STD-883, Method 30157. Machine Model, applicable std. JESD22-A115-A (ESD MM std. of JEDEC). Field-Induced Charge-Device Model, applicable std. JESD22-C101-C (ESD FICDM std. of JEDEC).

**Note 6:** Short circuit current should be limited in duration to no more than 10 seconds. See the Power Dissipation section of the Application Information for more details.

**Note 7:** Typical values represent the most likely parametric norm as determined at the time of characterization. Actual typical values may vary over time and will also depend on the application and configuration. The typical values are not tested and are not guaranteed on shipped production material.

**Note 8:** Limits are 100% production tested at 25°C. Limits over the operating temperature range are guaranteed through correlation using Statistical Quality Control (SQC) methods.

**Note 9:** Negative input current implies current flowing out of the device.

**Note 10:**  $I_{BI}$  is referred to a differential output offset voltage by the following relationship:  $V_{OD(OFFSET)} = I_{BI} * 2R_F$

## Connection Diagram

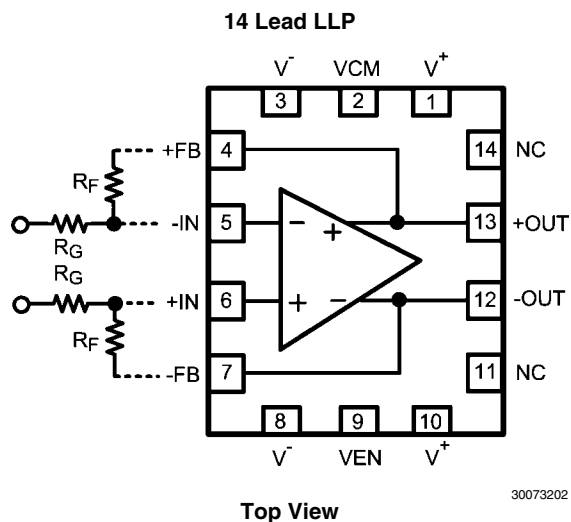

## Pin Descriptions

Pin No.	Pin Name	Description
1	V+	Positive Supply
2	VCM	Output Common Mode Control
3	V-	Negative Supply
4	+FB	Feedback Output +
5	-IN	Negative Input
6	+IN	Positive Input
7	-FB	Feedback Output -
8	V-	Negative Supply
9	VEN	Enable. Active high
10	V+	Positive Supply
11	NC	No Connect
12	-OUT	Negative Output
13	+OUT	Positive Output
14	NC	No Connect

## Ordering Information

Package	Part Number	Package Marking	Transport Media	NSC Drawing
14 Lead LLP	LMH6554LE	AJA	1k Units Tape and Reel	LEE14A
	LMH6554LEE		250 Units Tape and Reel	
	LMH6554LEX		4.5k Units Tape and Reel	

**Typical Performance Characteristics  $V_S = \pm 2.5V$**  ( $T_A = 25^\circ C$ ,  $R_F = 200\Omega$ ,  $R_G = 200\Omega$ ,  $R_L = 200\Omega$ ,  $A_V = +2$ , for single ended in, differential out, unless specified).  
 查询LMH6554"供应商

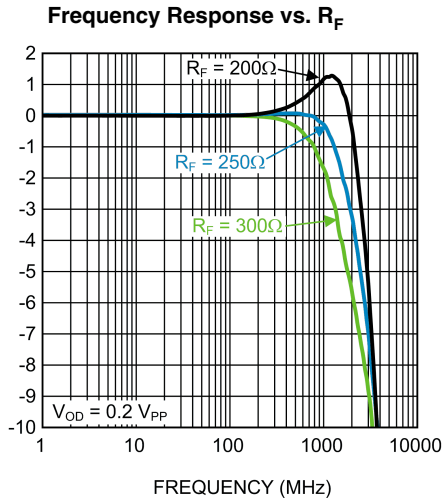

30073251

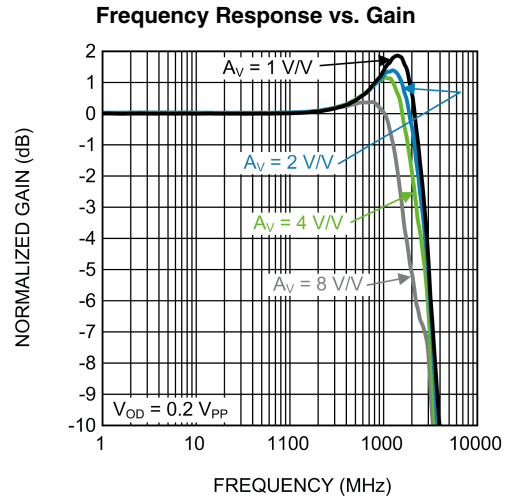

30073211

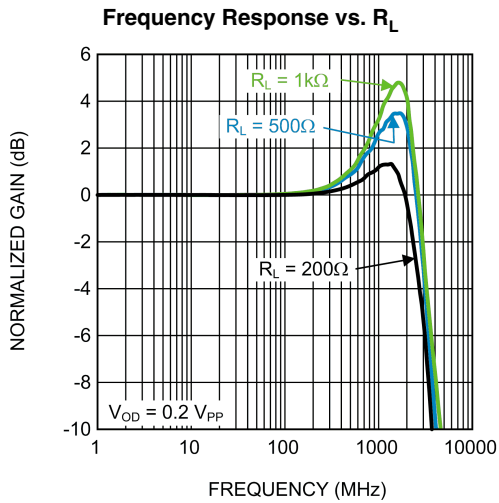

30073252

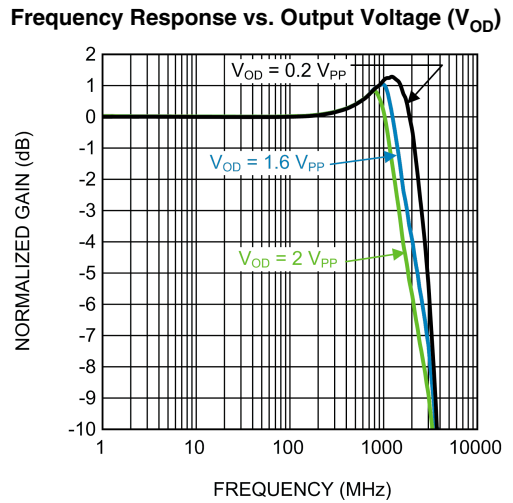

30073213

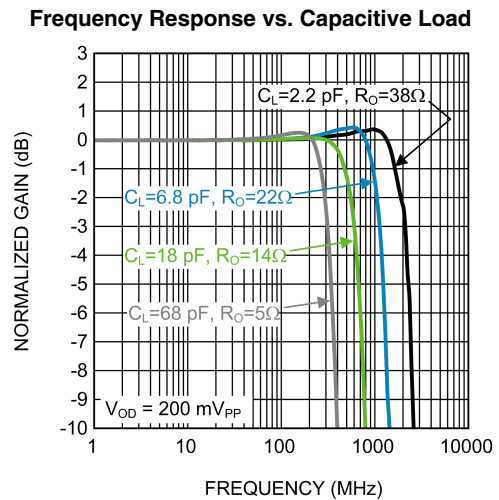

30073217

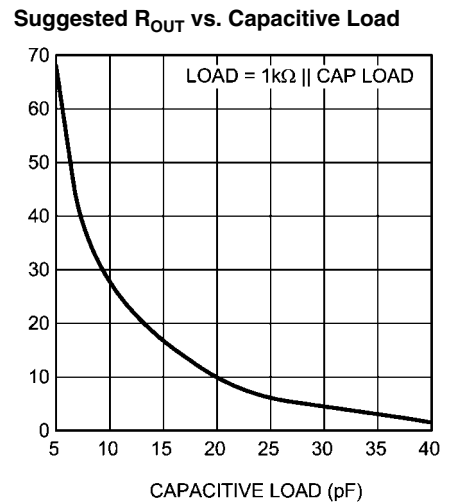

30073218

0.5 V<sub>PP</sub> Pulse Response Single Ended Input  
 查询"LMH6554"供应商

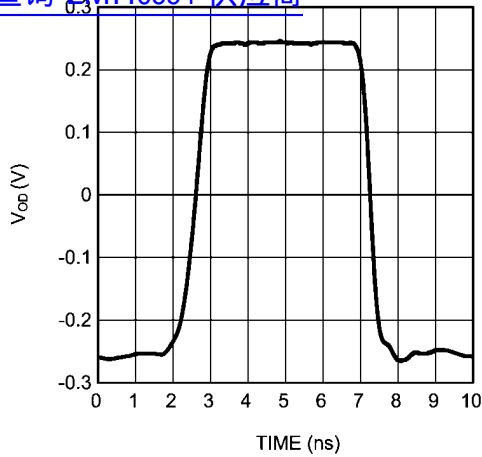

30073253

2 V<sub>PP</sub> Pulse Response Single Ended Input

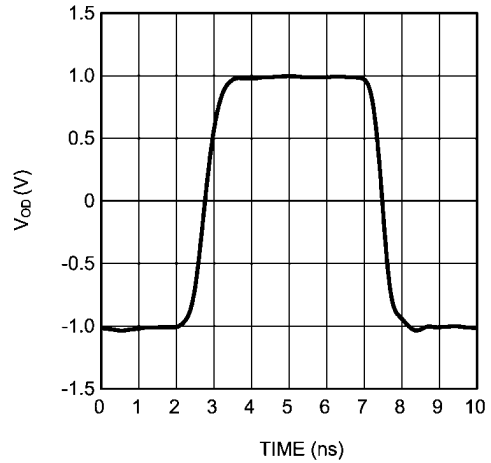

30073254

4 V<sub>PP</sub> Pulse Response Single Ended Input

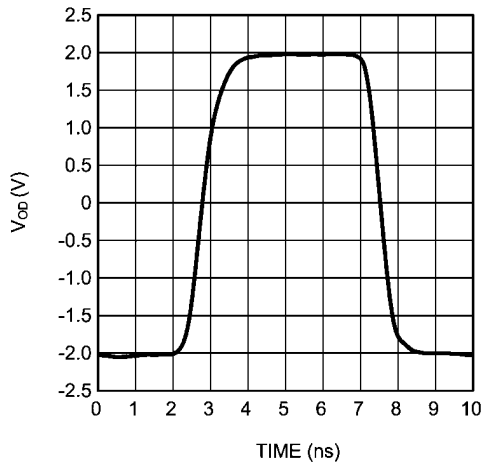

30073255

Distortion vs. Frequency Single Ended Input

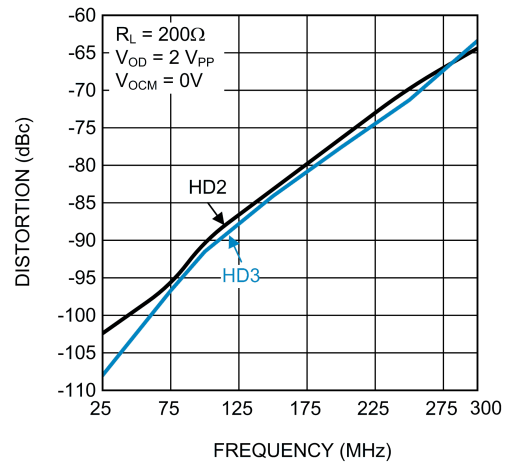

30073228

Distortion vs. Output Common Mode Voltage

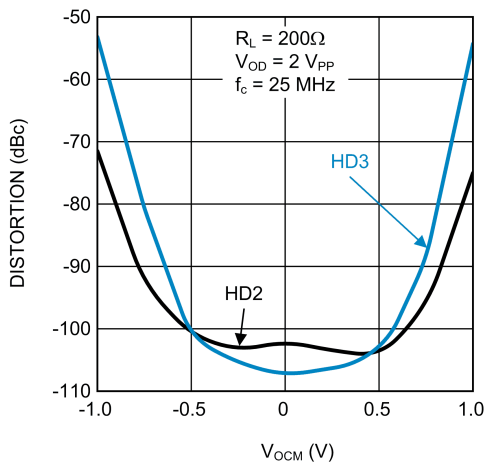

30073233

Distortion vs. Output Common Mode Voltage

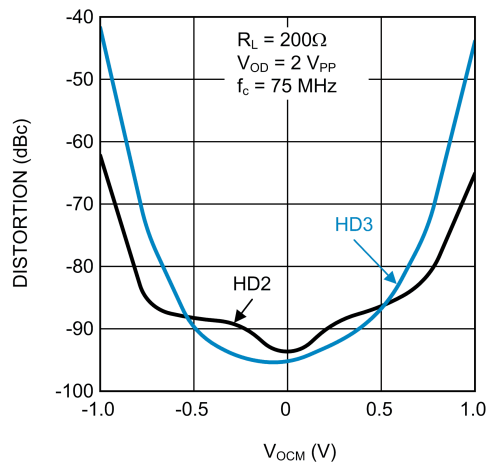

30073234

查询"LMH6554"供应商

**Distortion vs. Output Common Mode Voltage**

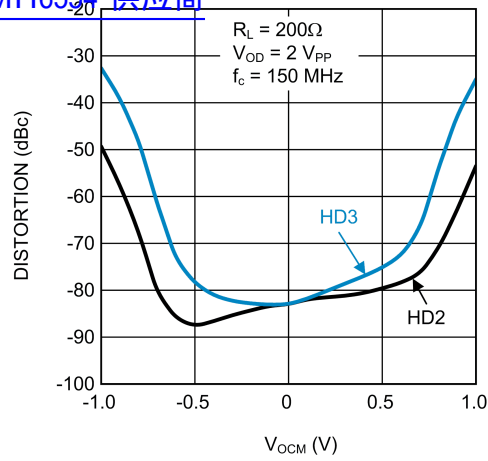

30073235

**3rd Order Intermodulation Products vs  $V_{OUT}$**

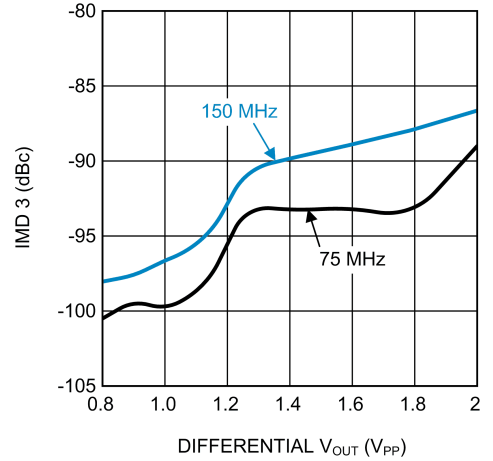

30073248

**OIP3 vs Output Power  $P_{OUT}$**

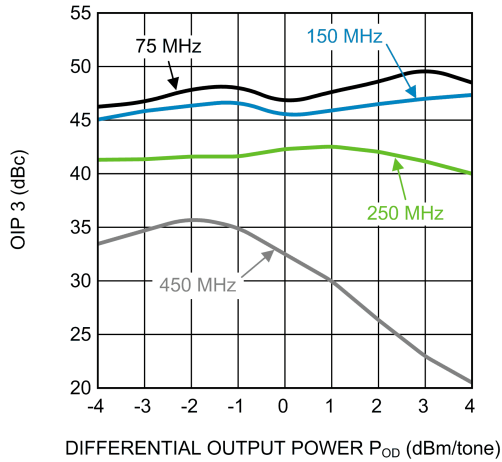

30073249

**OIP3 vs Center Frequency**

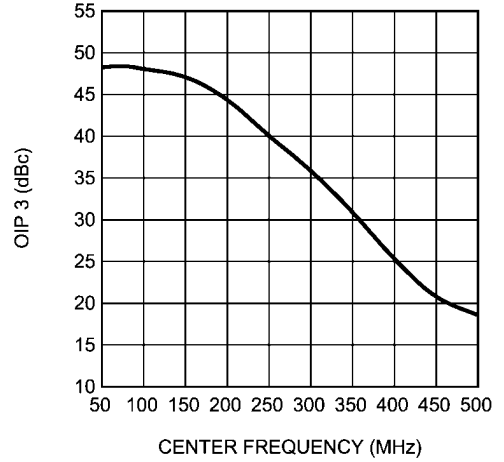

30073250

**Maximum  $V_{OUT}$  vs.  $I_{OUT}$**

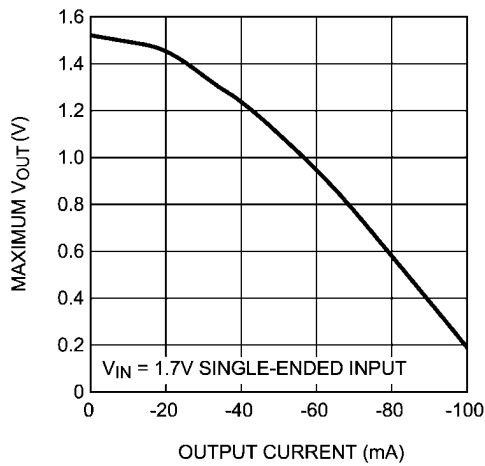

30073236

**Minimum  $V_{OUT}$  vs.  $I_{OUT}$**

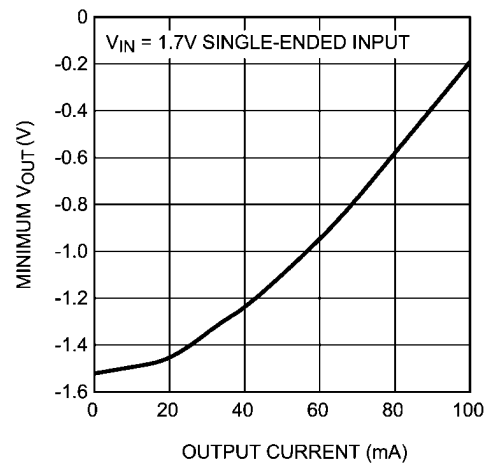

30073237



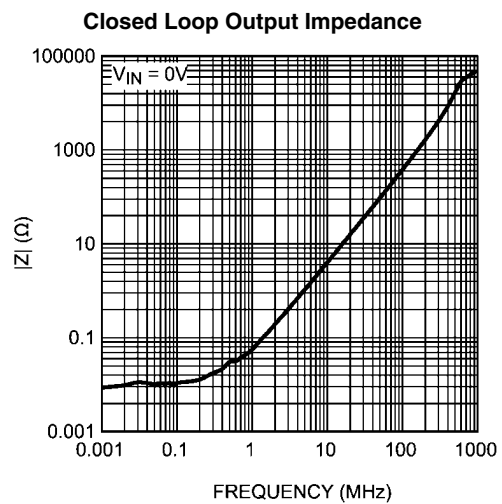
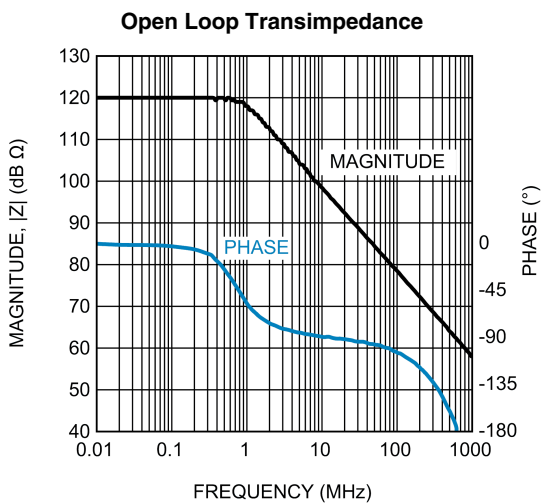
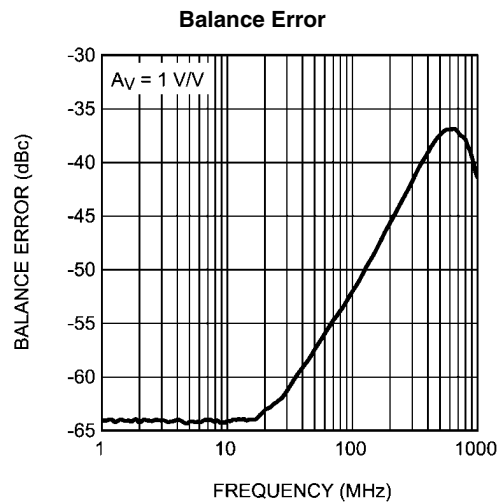
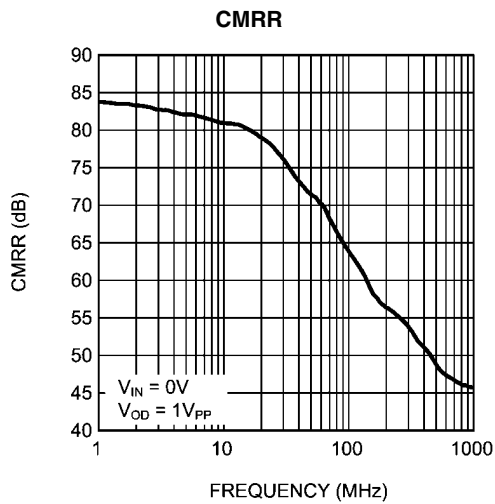
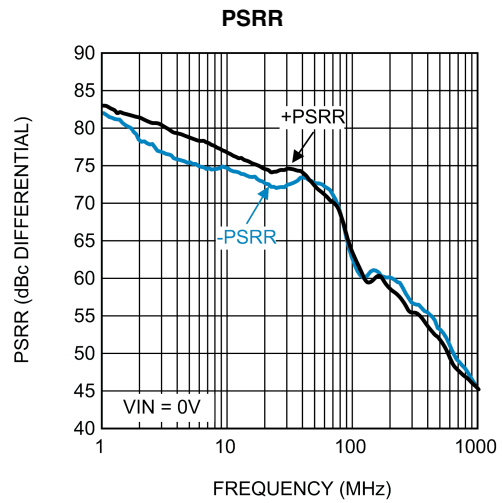
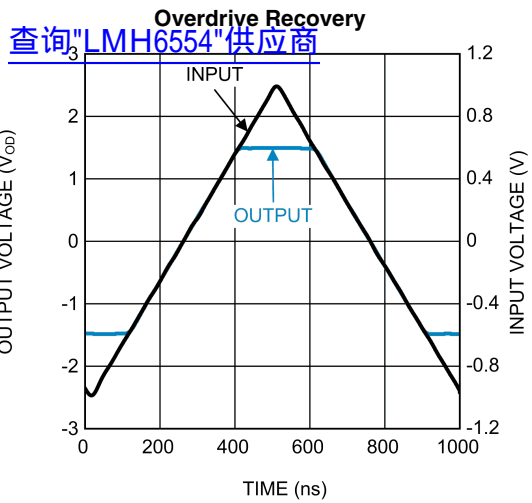

### Differential S-Parameter Magnitude vs. Frequency

[查询"LMH6554"供应商](#)

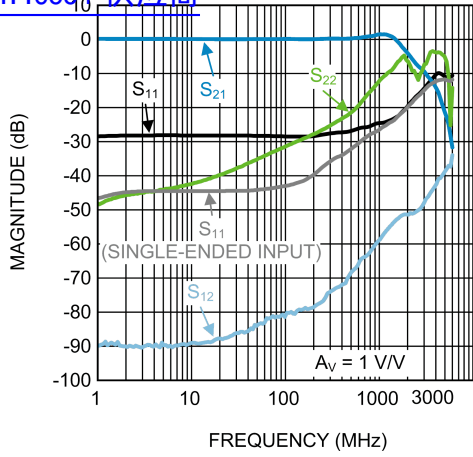

30073246

## Application Information

The LMH6554 is a fully differential, current feedback amplifier with integrated output common mode control, designed to provide low distortion amplification to wide bandwidth differential signals. The common mode feedback circuit sets the output common mode voltage independent of the input common mode, as well as forcing the  $V^+$  and  $V^-$  outputs to be equal in magnitude and opposite in phase, even when only one of the inputs is driven as in single to differential conversion.

The proprietary current feedback architecture of the LMH6554 offers gain and bandwidth independence with exceptional gain flatness and noise performance, even at high values of gain, simply with the appropriate choice of  $R_{F1}$  and  $R_{F2}$ . Generally  $R_{F1}$  is set equal to  $R_{F2}$ , and  $R_{G1}$  equal to  $R_{G2}$ , so that the gain is set by the ratio  $R_F/R_G$ . Matching of these resistors greatly affects CMRR, DC offset error, and output balance. A maximum of 0.1% tolerance resistors are recommended for optimal performance, and the amplifier is internally compensated to operate with optimum gain flatness with  $R_F$  value of 200Ω depending on PCB layout, and load resistance.

The output common mode voltage is set by the  $V_{CM}$  pin with a fixed gain of 1 V/V. This pin should be driven by a low impedance reference and should be bypassed to ground with a 0.1 μF ceramic capacitor. Any unwanted signal coupling into the  $V_{CM}$  pin will be passed along to the outputs, reducing the performance of the amplifier.

The LMH6554 can be configured to operate on a single 5V supply connected to  $V^+$  with  $V^-$  grounded or configured for a split supply operation with  $V^+ = +2.5V$  and  $V^- = -2.5V$ . Operation on a single 5V supply, depending on gain, is limited by the input common mode range; therefore, AC coupling may be required. Split supplies will allow much less restricted AC and DC coupled operation with optimum distortion performance.

The LMH6554 is equipped with an enable pin (VEN) to reduce power consumption when not in use. The VEN pin, when not driven, floats high (on). When the VEN pin is pulled low the amplifier is disabled and the amplifier output stage goes into a high impedance state so the feedback and gain set resistors determine the output impedance of the circuit. For this reason input to output isolation will be poor in the disabled state and the part is not recommended in multiplexed applications where outputs are all tied together.

## Fully Differential Operation

The LMH6554 will perform best in a fully differential configuration. The circuit shown in [Figure 1](#) is a typical fully differential application circuit as might be used to drive an analog to digital converter (ADC). In this circuit the closed loop gain is  $A_V = V_{OUT}/V_{IN} = R_F/R_G$ , where the feedback is symmetric. The series output resistors,  $R_O$ , are optional and help keep the amplifier stable when presented with a capacitive load. Refer to the Driving Capacitive Loads section for details.

When driven from a differential source, the LMH6554 provides low distortion, excellent balance, and common mode rejection. This is true provided the resistors  $R_F$ ,  $R_G$  and  $R_O$  are well matched and strict symmetry is observed in board layout. With an intrinsic device CMRR of greater than 70 dB, using 0.1% resistors will give a worst case CMRR of around 50 dB for most circuits.

The circuit configuration shown in [Figure 1](#) was used to measure differential S-parameters in a 100Ω environment at a

gain of 1 V/V. Refer to the Differential S-Parameter vs. Frequency Plots in the Typical Performance Characteristics section for measurement results.

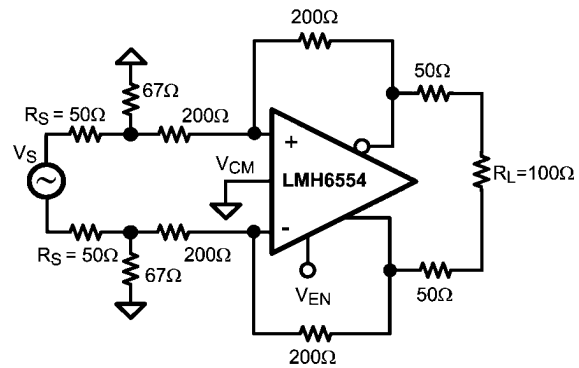

30073257

FIGURE 1. Differential S-Parameter Test Circuit

## Single Ended Input To Differential Output Operation

In many applications, it is required to drive a differential input ADC from a single ended source. Traditionally, transformers have been used to provide single to differential conversion, but these are inherently bandpass by nature and cannot be used for DC coupled applications. The LMH6554 provides excellent performance as a single-ended input to differential output converter down to DC. [Figure 2](#) shows a typical application circuit where an LMH6554 is used to produce a balanced differential output signal from a single ended source.

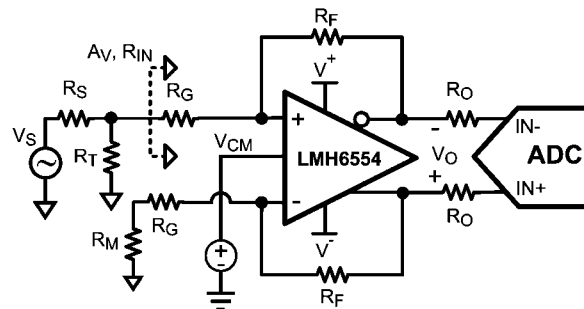

$$A_V = \left( \frac{2(1 - \beta_1)}{\beta_1 - \beta_2} \right) \quad \beta_1 = \left( \frac{R_G}{R_G + R_F} \right)$$

$$R_{IN} = \left( \frac{2R_G + R_M(1 - \beta_2)}{1 + \beta_2} \right) \quad \beta_2 = \left( \frac{R_G + R_M}{R_G + R_F + R_M} \right)$$

$$R_S = R_T \parallel R_{IN}$$

$$R_M = R_T \parallel R_S$$

30073258

FIGURE 2. Single Ended Input with Differential Output

When using the LMH6554 in single-to-differential mode, the complimentary output is forced to a phase inverted replica of the driven output by the common mode feedback circuit as opposed to being driven by its own complimentary input. Consequently, as the driven input changes, the common mode feedback action results in a varying common mode voltage at the amplifier's inputs, proportional to the driving signal. Due to the non-ideal common mode rejection of the amplifier's input stage, a small common mode signal appears at the out-

查询LMH6554 为芯商

puts which is superimposed on the differential output signal. The ratio of the change in output common mode voltage to output differential voltage is commonly referred to as output balance error. The output balance error response of the LMH6554 over frequency is shown in the Typical Performance Characteristics section.

To match the input impedance of the circuit in *Figure 2* to a specified source resistance,  $R_S$ , requires that  $R_T \parallel R_{IN} = R_S$ . The equations governing  $R_{IN}$  and  $A_V$  for single-to-differential operation are also provide in *Figure 2*. These equations, along with the source matching condition, must be solved iteratively to achieve the desired gain with the proper input termination. Component values for several common gain configuration in a  $50\Omega$  environment are given in Table 1.

**Table 1. Gain Component Values for  $50\Omega$  System**

Gain	$R_F$	$R_G$	$R_T$	$R_M$
0dB	$200\Omega$	$191\Omega$	$62\Omega$	$27.7\Omega$
6dB	$200\Omega$	$91\Omega$	$76.8\Omega$	$30.3\Omega$
12dB	$200\Omega$	$35.7\Omega$	$147\Omega$	$37.3\Omega$

## Single Supply Operation

Single 5V supply operation is possible: however, as discussed earlier, AC input coupling is recommended due to input common mode limitations. An example of an AC coupled, single supply, single-to-differential circuit is shown in *Figure 3*. Note that when AC coupling, both inputs need to be AC coupled irrespective of single-to-differential or differential-differential configuration. For higher supply voltages DC coupling of the inputs may be possible provided that the output common mode DC level is set high enough so that the amplifier's inputs and outputs are within their specified operation ranges.

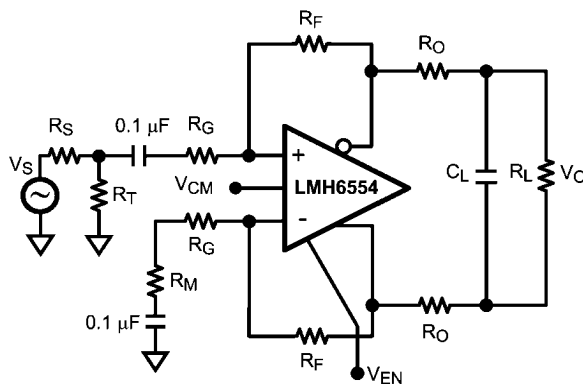

30073260

**FIGURE 3. AC Coupled for Single Supply Operation**

## Split Supply Operation

For optimum performance, split supply operation is recommended using +2.5V and -2.5V supplies; however, operation is possible on split supplies as low as +2.35V and -2.35V and as high as +2.65V and -2.65V. Provided the total supply voltage does not exceed the 4.7V to 5.3V operating specification, non-symmetric supply operation is also possible and in some cases advantageous. For example, if a 5V DC coupled operation is required for low power dissipation but the amplifier input common mode range prevents this operation, it is still possible with split supplies of (V+) and (V-). Where (V+)-(V-)

= 5V and V+ and V- are selected to center the amplifier input common mode range to suit the application.

## Driving Analog To Digital Converters

Analog-to-digital converters present challenging load conditions. They typically have high impedance inputs with large and often variable capacitive components. *Figure 5* shows the LMH6554 driving an ultra-high-speed Gigasample ADC the ADC10D1500. The LMH6554 common mode voltage is set by the ADC10D1500. The circuit in *Figure 5* has a 2nd order bandpass LC filter across the differential inputs of the ADC10D1500. The ADC10D1500 is a dual channel 10-bit ADC with maximum sampling rate of 3 GSPS when operating in a single channel mode and 1.5 GSPS in dual channel mode.

*Figure 4* shows the SFDR and SNR performance vs. frequency for the LMH6554 and ADC10D1500 combination circuit with the ADC input signal level at -1 dBFS. In order to properly match the input impedance seen at the LMH6554 amplifier inputs,  $R_M$  is chosen to match  $Z_S \parallel R_T$  for proper input balance. The amplifier is configured to provide a gain of 2 V/V in single to differential mode. An external bandpass filter is inserted in series between the input signal source and the amplifier to reduce harmonics and noise from the signal generator.

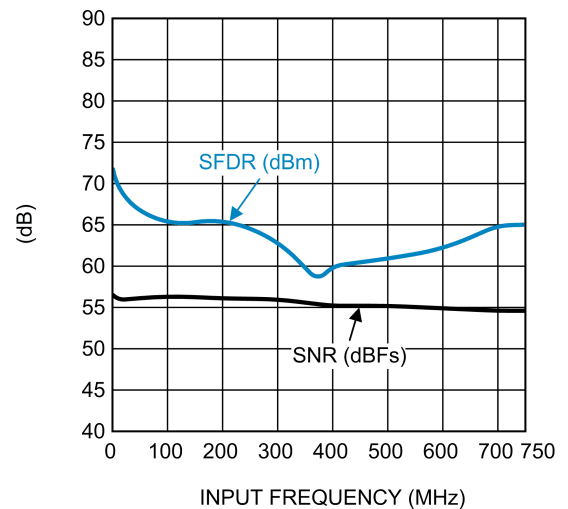

30073265

**FIGURE 4. LMH6554/ADC10D1500 SFDR and SNR Performance vs. Frequency**

The amplifier and ADC should be located as close together as possible. Both devices require that the filter components be in close proximity to them. The amplifier needs to have minimal parasitic loading on its outputs and the ADC is sensitive to high frequency noise that may couple in on its inputs. Some high performance ADCs have an input stage that has a bandwidth of several times its sample rate. The sampling process results in all input signals presented to the input stage mixing down into the first Nyquist zone (DC to  $F_s/2$ ).

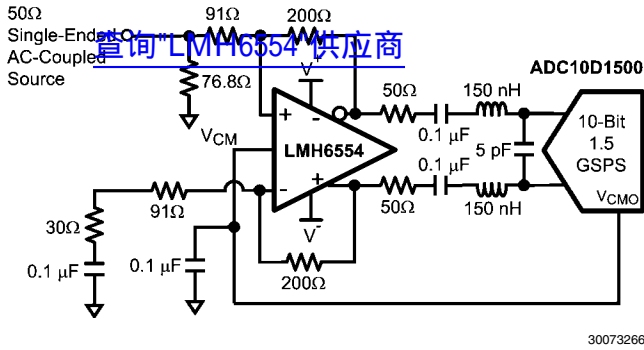

FIGURE 5. Driving a 10-bit Gigasample ADC

## Output Noise Performance and Measurement

Unlike differential amplifiers based on voltage feedback architectures, noise sources internal to the LMH6554 refer to the inputs largely as current sources, hence the low input referred voltage noise and relatively higher input referred current noise. The output noise is therefore more strongly coupled to the value of the feedback resistor and not to the closed loop gain, as would be the case with a voltage feedback differential amplifier. This allows operation of the LMH6554 at much higher gain without incurring a substantial noise performance penalty, simply by choosing a suitable feedback resistor.

Figure 6 shows a circuit configuration used to measure noise figure for the LMH6554 in a 50Ω system. A feedback resistor value of 200Ω is chosen for the LLP package to minimize output noise while simultaneously allowing both high gain (7 V/V) and proper 50Ω input termination. Refer to the section titled Single Ended Input Operation for calculation of resistor and gain values. Noise figure values at various frequencies are shown in the plot titled Noise Figure in the Typical Performance Characteristics section.

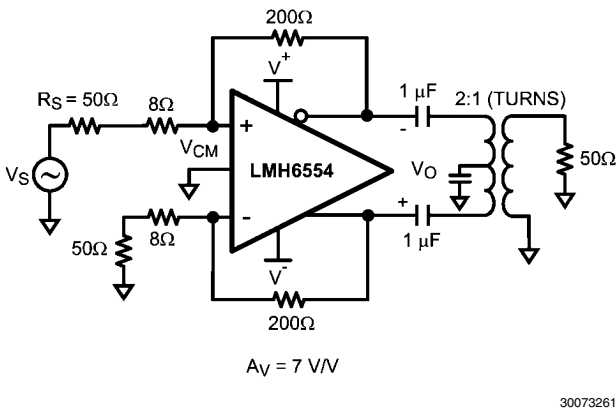

FIGURE 6. Noise Figure Circuit Configuration

## Driving Capacitive Loads

As noted previously, capacitive loads should be isolated from the amplifier output with small valued resistors. This is particularly the case when the load has a resistive component that is 500Ω or higher. A typical ADC has capacitive components of around 10 pF and the resistive component could be 1000Ω or higher. If driving a transmission line, such as 50Ω

coaxial or 100Ω twisted pair, using matching resistors will be sufficient to isolate any subsequent capacitance. For other applications see the Suggested R<sub>OUT</sub> vs. Capacitive Load charts in the Typical Performance Characteristics section.

## Balanced Cable Driver

With up to 5.68 V<sub>PP</sub> differential output voltage swing the LMH6554 can be configured as a cable driver. The LMH6554 is also suitable for driving differential cables from a single ended source as shown in Figure 7.

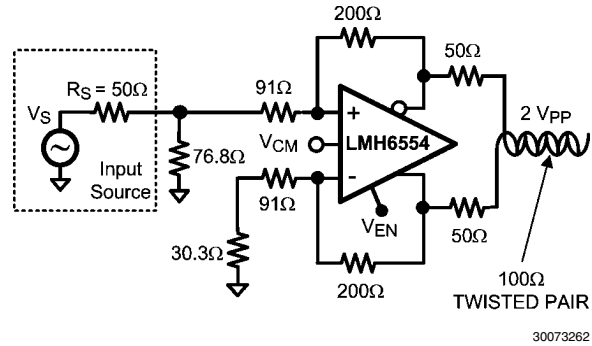

FIGURE 7. Fully Differential Cable Driver

## Power Supply Bypassing

The LMH6554 requires supply bypassing capacitors as shown in Figure 8 and Figure 9. The 0.01 μF and 0.1 μF capacitors should be leadless SMT ceramic capacitors and should be no more than 3 mm from the supply pins. These capacitors should be star routed with a dedicated ground return plane or trace for best harmonic distortion performance. Thin traces or small vias will reduce the effectiveness of bypass capacitors. Also shown in both figures is a capacitor from the V<sub>CM</sub> and V<sub>EN</sub> pins to ground. These inputs are high impedance and can provide a coupling path into the amplifier for external noise sources, possibly resulting in loss of dynamic range, degraded CMRR, degraded balance and higher distortion.

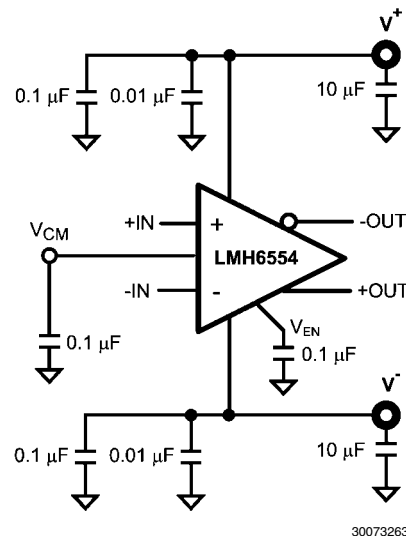

FIGURE 8. Split Supply Bypassing Capacitors

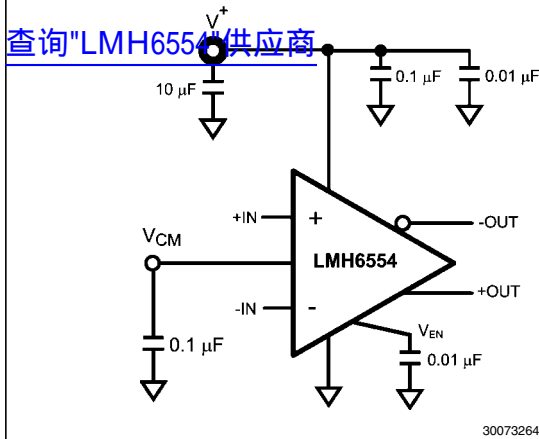

FIGURE 9. Single Supply Bypassing Capacitors

## Power Dissipation

The LMH6554 is optimized for maximum speed and performance in a small form factor 14 lead LLP package. To ensure maximum output drive and highest performance, thermal shutdown is not provided. Therefore, it is of utmost importance to make sure that the  $T_{JMAX}$  is never exceeded due to the overall power dissipation.

Follow these steps to determine the maximum power dissipation for the LMH6554:

1. Calculate the quiescent (no-load) power:  $P_{AMP} = I_{CC} * (V_S)$ , where  $V_S = V^+ - V^-$ . (Be sure to include any current through the feedback network if  $V_{CM}$  is not mid-rail).
2. Calculate the RMS power dissipated in each of the output stages:  $P_D (rms) = rms ((V_S - V_{+OUT}) * I_{+OUT}) + rms ((V_S - V_{-OUT}) * I_{-OUT})$ , where  $V_{OUT}$  and  $I_{OUT}$  are the voltage and the current measured at the output pins of the differential amplifier as if they were single ended amplifiers and  $V_S$  is the total supply voltage.
3. Calculate the total RMS power:  $P_T = P_{AMP} + P_D$ .

The maximum power that the LMH6554 package can dissipate at a given temperature can be derived with the following equation:

$P_{MAX} = (150^\circ - T_{AMB}) / \theta_{JA}$ , where  $T_{AMB}$  = Ambient temperature ( $^\circ C$ ) and  $\theta_{JA}$  = Thermal resistance, from junction to ambient, for a given package ( $^\circ C/W$ ). For the 14 lead LLP package,  $\theta_{JA}$  is  $60^\circ C/W$ .

NOTE: If  $V_{CM}$  is not 0V then there will be quiescent current flowing in the feedback network. This current should be in-

cluded in the thermal calculations and added into the quiescent power dissipation of the amplifier.

## ESD Protection

The LMH6554 is protected against electrostatic discharge (ESD) on all pins. The LMH6554 will survive 2000V Human Body model and 250V Machine model events. Under normal operation the ESD diodes have no effect on circuit performance. There are occasions, however, when the ESD diodes will be evident. If the LMH6554 is driven by a large signal while the device is powered down the ESD diodes will conduct. The current that flows through the ESD diodes will either exit the chip through the supply pins or will flow through the device, hence it is possible to power up a chip with a large signal applied to the input pins. Using the shutdown mode is one way to conserve power and still prevent unexpected operation.

## Board Layout

The LMH6554 is a high speed, high performance amplifier. In order to get maximum benefit from the differential circuit architecture board layout and component selection is very critical. The circuit board should have a low inductance ground plane and well bypassed broad supply lines. External components should be leadless surface mount types. The feedback network and output matching resistors should be composed of short traces and precision resistors (0.1%). The output matching resistors should be placed within 3 or 4 mm of the amplifier as should the supply bypass capacitors. Refer to the section titled Power Supply Bypassing for recommendations on bypass circuit layout. Evaluation boards are available through the product folder on National's web site.

By design, the LMH6554 is relatively insensitive to parasitic capacitance at its inputs. Nonetheless, ground and power plane metal should be removed from beneath the amplifier and from beneath  $R_F$  and  $R_G$  for best performance at high frequency.

With any differential signal path, symmetry is very important. Even small amounts of asymmetry can contribute to distortion and balance errors.

## Evaluation Board

See the LMH6554 Product Folder on [www.national.com](http://www.national.com) for evaluation board availability and ordering information.

**Physical Dimensions** inches (millimeters) unless otherwise noted  
[查询"LMH6554"供应商](#)

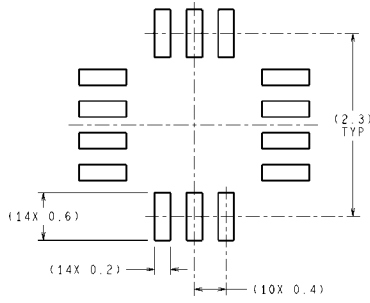

RECOMMENDED LAND PATTERN

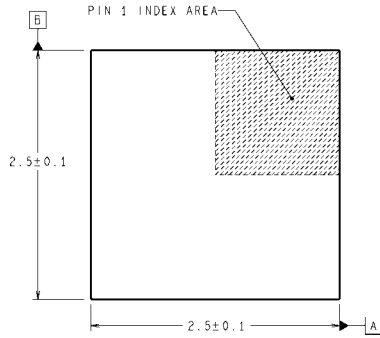

DIMENSIONS ARE IN MILLIMETERS  
 DIMENSION IN ( ) FOR REFERENCE ONLY

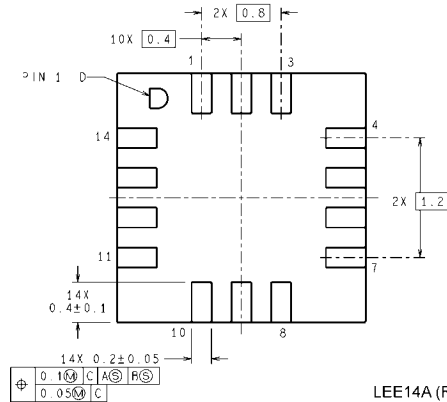
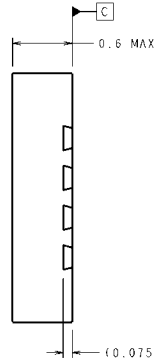
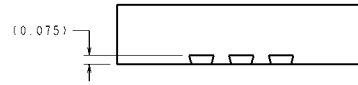

0	10	C	A	R
0	05	C		

LEE14A (Rev B)

**14-Pin LLP**  
**NS Package Number LEE14A**

[查询"LMH6554"供应商](#)

## Notes

For more National Semiconductor product information and proven design tools, visit the following Web sites at:  
[www.national.com](http://www.national.com)

Products		Design Support	
Amplifiers	<a href="http://www.national.com/amplifiers">www.national.com/amplifiers</a>	WEBENCH® Tools	<a href="http://www.national.com/webench">www.national.com/webench</a>
Audio	<a href="http://www.national.com/audio">www.national.com/audio</a>	App Notes	<a href="http://www.national.com/appnotes">www.national.com/appnotes</a>
Clock and Timing	<a href="http://www.national.com/timing">www.national.com/timing</a>	Reference Designs	<a href="http://www.national.com/refdesigns">www.national.com/refdesigns</a>
Data Converters	<a href="http://www.national.com/adc">www.national.com/adc</a>	Samples	<a href="http://www.national.com/samples">www.national.com/samples</a>
Interface	<a href="http://www.national.com/interface">www.national.com/interface</a>	Eval Boards	<a href="http://www.national.com/evalboards">www.national.com/evalboards</a>
LVDS	<a href="http://www.national.com/lvds">www.national.com/lvds</a>	Packaging	<a href="http://www.national.com/packaging">www.national.com/packaging</a>
Power Management	<a href="http://www.national.com/power">www.national.com/power</a>	Green Compliance	<a href="http://www.national.com/quality/green">www.national.com/quality/green</a>
Switching Regulators	<a href="http://www.national.com/switchers">www.national.com/switchers</a>	Distributors	<a href="http://www.national.com/contacts">www.national.com/contacts</a>
LDOs	<a href="http://www.national.com/ldo">www.national.com/ldo</a>	Quality and Reliability	<a href="http://www.national.com/quality">www.national.com/quality</a>
LED Lighting	<a href="http://www.national.com/led">www.national.com/led</a>	Feedback/Support	<a href="http://www.national.com/feedback">www.national.com/feedback</a>
Voltage References	<a href="http://www.national.com/vref">www.national.com/vref</a>	Design Made Easy	<a href="http://www.national.com/easy">www.national.com/easy</a>
PowerWise® Solutions	<a href="http://www.national.com/powerwise">www.national.com/powerwise</a>	Applications & Markets	<a href="http://www.national.com/solutions">www.national.com/solutions</a>
Serial Digital Interface (SDI)	<a href="http://www.national.com/sdi">www.national.com/sdi</a>	Mil/Aero	<a href="http://www.national.com/milaero">www.national.com/milaero</a>
Temperature Sensors	<a href="http://www.national.com/tempensors">www.national.com/tempensors</a>	SolarMagic™	<a href="http://www.national.com/solarmagic">www.national.com/solarmagic</a>
PLL/VCO	<a href="http://www.national.com/wireless">www.national.com/wireless</a>	PowerWise® Design University	<a href="http://www.national.com/training">www.national.com/training</a>

THE CONTENTS OF THIS DOCUMENT ARE PROVIDED IN CONNECTION WITH NATIONAL SEMICONDUCTOR CORPORATION ("NATIONAL") PRODUCTS. NATIONAL MAKES NO REPRESENTATIONS OR WARRANTIES WITH RESPECT TO THE ACCURACY OR COMPLETENESS OF THE CONTENTS OF THIS PUBLICATION AND RESERVES THE RIGHT TO MAKE CHANGES TO SPECIFICATIONS AND PRODUCT DESCRIPTIONS AT ANY TIME WITHOUT NOTICE. NO LICENSE, WHETHER EXPRESS, IMPLIED, ARISING BY ESTOPPEL OR OTHERWISE, TO ANY INTELLECTUAL PROPERTY RIGHTS IS GRANTED BY THIS DOCUMENT.

TESTING AND OTHER QUALITY CONTROLS ARE USED TO THE EXTENT NATIONAL DEEMS NECESSARY TO SUPPORT NATIONAL'S PRODUCT WARRANTY. EXCEPT WHERE MANDATED BY GOVERNMENT REQUIREMENTS, TESTING OF ALL PARAMETERS OF EACH PRODUCT IS NOT NECESSARILY PERFORMED. NATIONAL ASSUMES NO LIABILITY FOR APPLICATIONS ASSISTANCE OR BUYER PRODUCT DESIGN. BUYERS ARE RESPONSIBLE FOR THEIR PRODUCTS AND APPLICATIONS USING NATIONAL COMPONENTS. PRIOR TO USING OR DISTRIBUTING ANY PRODUCTS THAT INCLUDE NATIONAL COMPONENTS, BUYERS SHOULD PROVIDE ADEQUATE DESIGN, TESTING AND OPERATING SAFEGUARDS.

EXCEPT AS PROVIDED IN NATIONAL'S TERMS AND CONDITIONS OF SALE FOR SUCH PRODUCTS, NATIONAL ASSUMES NO LIABILITY WHATSOEVER, AND NATIONAL DISCLAIMS ANY EXPRESS OR IMPLIED WARRANTY RELATING TO THE SALE AND/OR USE OF NATIONAL PRODUCTS INCLUDING LIABILITY OR WARRANTIES RELATING TO FITNESS FOR A PARTICULAR PURPOSE, MERCHANTABILITY, OR INFRINGEMENT OF ANY PATENT, COPYRIGHT OR OTHER INTELLECTUAL PROPERTY RIGHT.

### LIFE SUPPORT POLICY

**NATIONAL'S PRODUCTS ARE NOT AUTHORIZED FOR USE AS CRITICAL COMPONENTS IN LIFE SUPPORT DEVICES OR SYSTEMS WITHOUT THE EXPRESS PRIOR WRITTEN APPROVAL OF THE CHIEF EXECUTIVE OFFICER AND GENERAL COUNSEL OF NATIONAL SEMICONDUCTOR CORPORATION.** As used herein:

Life support devices or systems are devices which (a) are intended for surgical implant into the body, or (b) support or sustain life and whose failure to perform when properly used in accordance with instructions for use provided in the labeling can be reasonably expected to result in a significant injury to the user. A critical component is any component in a life support device or system whose failure to perform can be reasonably expected to cause the failure of the life support device or system or to affect its safety or effectiveness.

National Semiconductor and the National Semiconductor logo are registered trademarks of National Semiconductor Corporation. All other brand or product names may be trademarks or registered trademarks of their respective holders.

Copyright© 2010 National Semiconductor Corporation

For the most current product information visit us at [www.national.com](http://www.national.com)



**National Semiconductor  
Americas Technical  
Support Center**  
Email: [support@nsc.com](mailto:support@nsc.com)  
Tel: 1-800-272-9959

**National Semiconductor Europe  
Technical Support Center**  
Email: [europe.support@nsc.com](mailto:europe.support@nsc.com)

**National Semiconductor Asia  
Pacific Technical Support Center**  
Email: [ap.support@nsc.com](mailto:ap.support@nsc.com)

**National Semiconductor Japan  
Technical Support Center**  
Email: [jpn.feedback@nsc.com](mailto:jpn.feedback@nsc.com)