

## COMBINATION MOTOR DRIVER WITH DC-DC CONVERTER

Check for Samples: [DRV8808](#)

### FEATURES

- **Three DC Motor Drivers**
  - Up to 2.5-A Current Chopping
  - Low Typical ON Resistance ( $R_{\text{DS(ON)}} = 0.5 \Omega$  at  $T_J = 25^\circ\text{C}$ )
- **Three Integrated DC-DC Converters**
  - ON/OFF Selectable Using CSELECT Pin and Serial Interface
  - Outputs Configurable With External Resistor Network From 1 V to 90% of  $V_M$  Capability for All Three Channels
  - 1.35-A Output Capability for All Three Channels
- **One Integrated LDO Regulator**
  - Output Configurable With External Resistor Network from 1 V to 2.5 V
  - 550-mA Output Capability
- **7-V to 40-V Operating Range**
- **Serial Interface for Communications**
- **Thermally-Enhanced Surface-Mount Package**  
48-Pin HTSSOP With PowerPAD™
- **Power-Down Function (Deep-Sleep Mode)**
- **Reset Signal Output (Active Low)**
- **Reset (All Clear) Control Input**

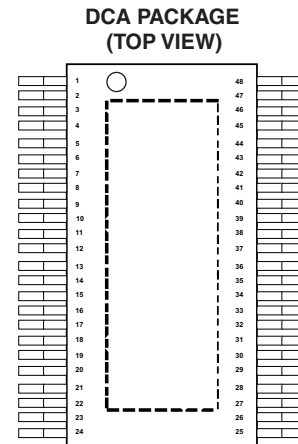

### DESCRIPTION

The DRV8808 provides the integrated motor driver solution for printers. The chip has three full H-bridges and three buck DC-DC converters.

The output driver block for each consists of N-channel power MOSFETs configured as full H-bridges to drive the motor windings. The device can be configured to utilize internal or external current sense for winding current control.

The SPI input pins are 3.3-V compatible and have 5-V-tolerant inputs.

The DRV8808 has three dc-dc switch-mode buck converters to generate a programmable output voltage from 1 V up to 90% of  $V_M$ , with up to 1.35-A load current capability.

The device is configured using the CSELECT terminal at start up, and serial interface during run time.

An internal shutdown function is provided for overcurrent protection, short-circuit protection, undervoltage lockout, and thermal shutdown. Also, the device has the reset function at power on, and the input on nReset pin.



Please be aware that an important notice concerning availability, standard warranty, and use in critical applications of Texas Instruments semiconductor products and disclaimers thereto appears at the end of this data sheet.

PowerPAD is a trademark of Texas Instruments.

BLOCK DIAGRAM

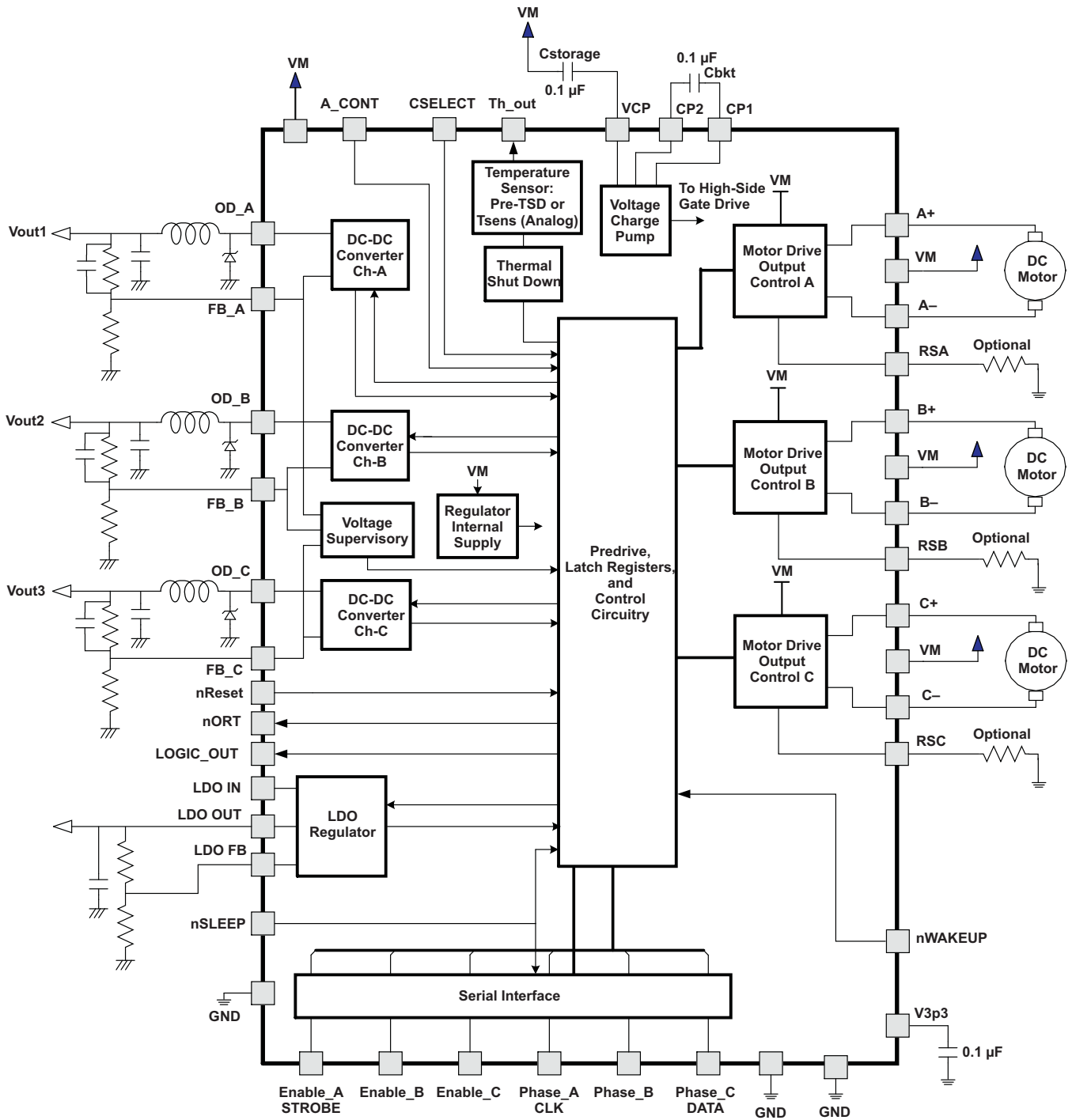

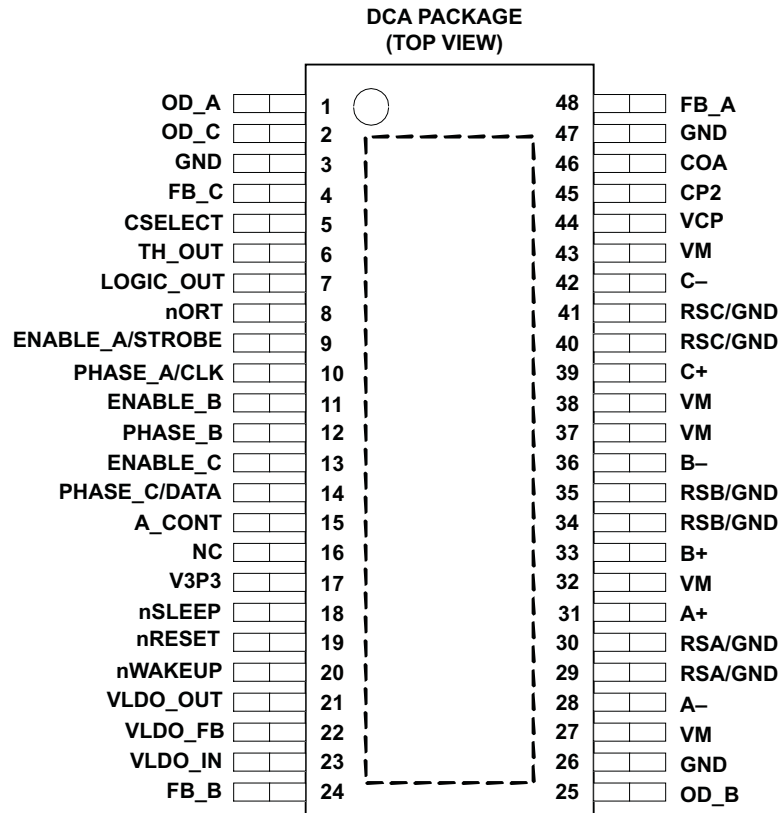

### TERMINAL FUNCTIONS

TERMINAL		I/O	PU/PD	SHUNT R	DESCRIPTION
NO.	NAME				
1	OD_A	O			Output for dc-dc switch mode regulator A
2	OD_C	O			Output for dc-dc switch mode regulator C
3	OD_VPEN	I			Input for Pen dc-dc switch mode regulator FET Source
4	G_VPEN	O			Output for Pen dc-dc switch mode regulator FET Gate Drive
5	GND	-			Ground
6	RSNS_P	I			Current Sensing Resistor for Pen dc-dc switch mode regulator
7	FB_C	I			Feedback signal for dc-dc converter C
8	FB_P	I			Feedback signal for Pen dc-dc converter
9	TH_OUT	O			Temperature warning output (Open drain)
10	LOGIC_OUT	O			Information monitoring output (Open drain)
11	nORT	IO			Reset input/output (Open drain)
12	ENA / STB	I	Down	100k	Enable input for dc Motor A control / SPI STROBE
13	PHA / CLK	I	Down	100k	Phase input for dc Motor A control / SPI CLOCK
14	ENB	I	Down	100k	Enable input for dc Motor B control
15	PHB	I	Down	100k	Phase input for dc Motor B control
16	ENC	I	Down	100k	Enable input for dc Motor C control
17	PHC / DATA	I	Down	100k	Phase input for dc Motor C control / SPI DATA
18	V3p3	O			Bypass for internal 3.3V regulator
19	nSLEEP	I	Down	100k	Enable/disable, SPI selector
20	nWAKEUP	I	Up	200k	Wake-up pin for DeepSleep Mode (L = WAKEUP)
21	VLDO_OUT	O			LDO Voltage Regulator Output
22	VLDO_FB	I			LDO Voltage Regulator Feed Back

**TERMINAL FUNCTIONS (continued)**

TERMINAL		I/O	PU/PD	SHUNT R	DESCRIPTION
NO.	NAME				
23	VLDO_IN	I			LDO Voltage Regulator Input
24	FB_B	I			Feedback signal for dc-dc converter B
25	OD_B	O			Output for dc-dc switch mode regulator B
26	GND	-			Ground
27	VM	-			Voltage supply for Motors and Regulators
28	A-	O			Motor drive output for winding A-
29	RSKA / GND	I			Motor drive Current Sensing Resistor A / GND Kelvin
30	RSA / GND	O			Motor drive Current Sensing Resistor A / GND Power
31	A+	O			Motor drive output for winding A+
32	VM	-			Voltage supply for Motors and Regulators
33	B+	O			Motor drive output for winding B+
34	RSKB / GND	I			Motor drive Current Sensing Resistor B / GND Kelvin
35	RSB / GND	O			Motor drive Current Sensing Resistor B / GND Power
36	B-	O			Motor drive output for winding B-
37	VM	-			Voltage supply for Motors and Regulators
38	VM	-			Voltage supply for Motors and Regulators
39	C+	O			Motor drive output for winding C+
40	RSKC / GND	I			Motor drive Current Sensing Resistor C / GND Kelvin
41	RSC / GND	O			Motor drive Current Sensing Resistor C / GND Power
42	C-	O			Motor drive output for winding C-
43	VM	-			Voltage supply for Motors and Regulators
44	VCP	O			Charge pump output
45	CP2	O			Charge pump bucket capacitor output (high side)
46	CP1	O			Charge pump bucket capacitor output (low side)
47	GND	-			Ground
48	FB_A	I			Feedback signal for dc-dc converter A

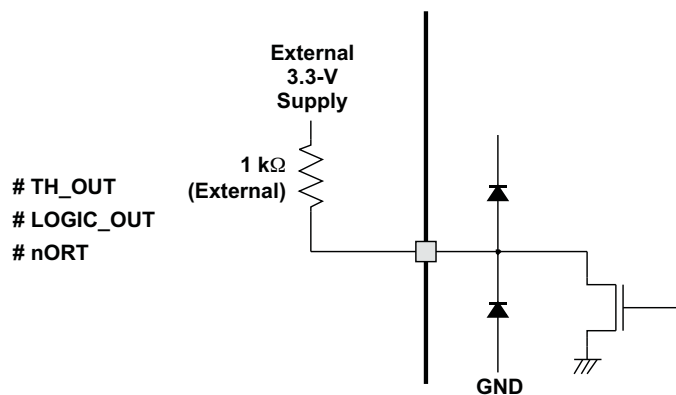
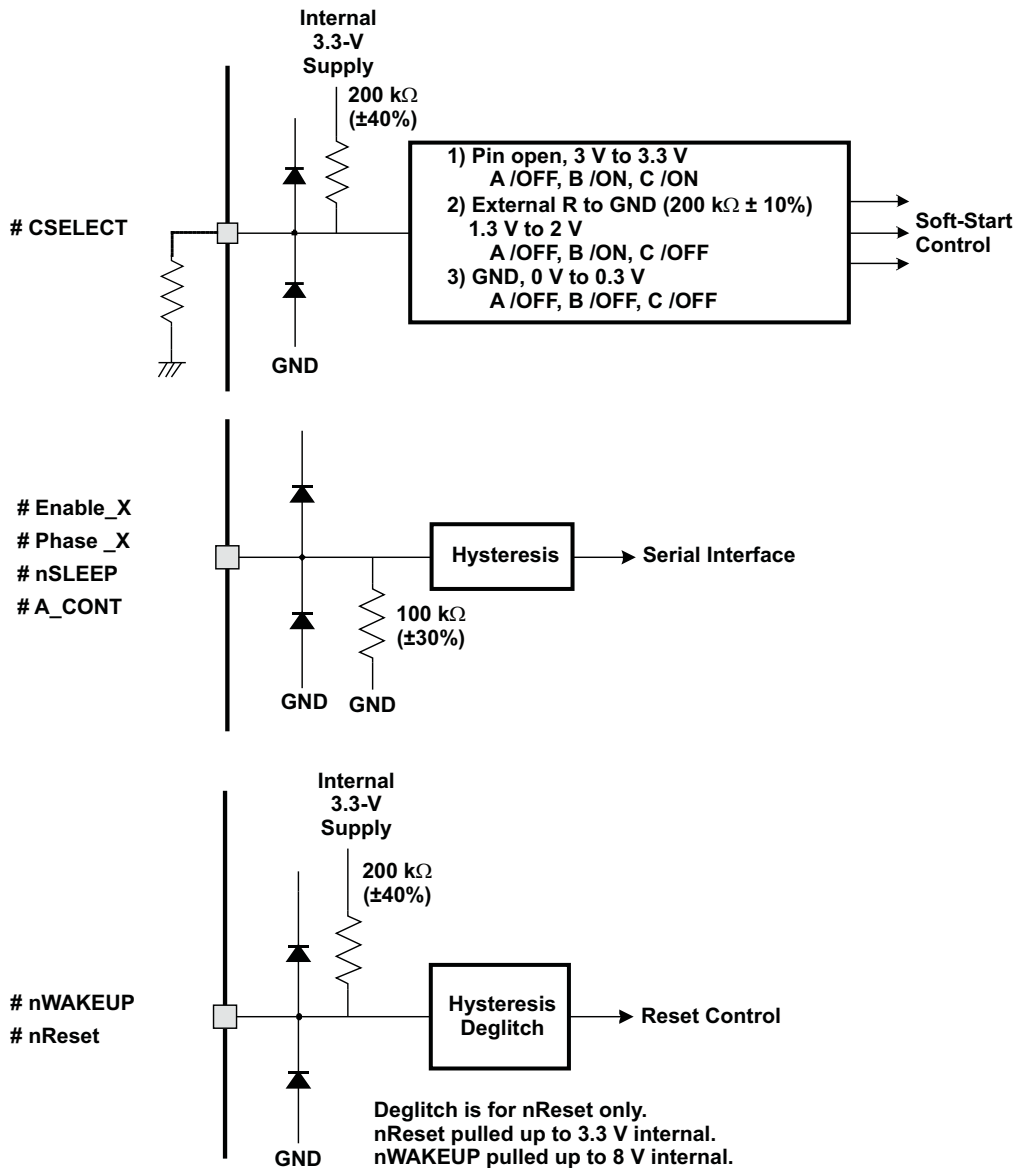

**ABSOLUTE MAXIMUM RATINGS<sup>(1)</sup>**

over operating free-air temperature range (unless otherwise noted)

	MAX	UNIT
V <sub>M</sub> Supply voltage	40	V
Logic input voltage range, serial I/F, A_CONT, nReset, etc. <sup>(2)</sup>	-0.3 to 5.5	V
TH_OUT, nORT, LOGIC_OUT, CSELECT	-0.3 to 3.6	V
nWAKEUP	-0.3 to 8	V
Continuous total power dissipation (in case $\theta_{JA} = 20^{\circ}\text{C/W}$ )	4	W
Continuous motor-drive output current for each H-bridge (100 ms)	2.5	A
Continuous dc-dc converter output current <sup>(3)</sup>	1.35	A
T <sub>J</sub> Operating junction temperature (1 hour)	190	°C
T <sub>stg</sub> Storage temperature range	-65 to 150	°C
Lead temperature 1.6 mm (1/16 in) from case for 10 s	260	°C
ESD levels on every pin, Human-Body Model (HBM)	2	kV

- (1) Stresses beyond those listed under “absolute maximum ratings” may cause permanent damage to the device. These are stress ratings only and functional operation of the device at these or any other conditions beyond those indicated under “recommended operating conditions” is not implied. Exposure to absolute-maximum-rated conditions for extended periods may affect device reliability.
- (2) The negative spike less than -5 V and narrower than 50-ns width should not cause any problem.
- (3) May shut down due to regulator OCP.

**RECOMMENDED OPERATING CONDITIONS**

	MIN	TYP	MAX	UNIT
Supply voltage range, V <sub>M</sub> for motor control	18	27	38	V
Supply voltage range for dc-dc converter (V <sub>M</sub> )	7	27	38	V
Operating ambient temperature range	-10		85	°C
Operating junction temperature range	0		135	°C

**ELECTRICAL CHARACTERISTICS**T<sub>J</sub> = 0°C to 135°C, V<sub>M</sub> = 7 V to 38 V (unless otherwise noted)

PARAMETER	TEST CONDITIONS	MIN	TYP	MAX	UNIT
<b>Supply (Sleep) Current</b>					
I <sub>SLEEP1</sub> Supply (sleep) current 1	nSLEEP = L, dc-dc all off		TBD	TBD	mA
I <sub>SLEEP2</sub> Supply (sleep) current 2	nSLEEP = L, V <sub>M</sub> = 8 V, Regulators enabled, No load		TBD	TBD	mA
I <sub>SLEEP3</sub> Supply (sleep) current 3	nSLEEP = L, V <sub>M</sub> = 38 V, Regulators enabled, No load		TBD	TBD	mA
I <sub>DEEP_SL</sub> Supply (deep sleep) current <sup>(1)</sup>	V <sub>M</sub> = 40 V		TBD	TBD	mA
<b>Digital Interface Circuit</b>					
V <sub>IH</sub> Digital high-level input voltage	Digital inputs	2		3.6	V
I <sub>IH</sub> Digital high-level input current	Digital inputs			100	μA
V <sub>IL</sub> Digital low-level input voltage	Digital inputs			0.8	V
I <sub>IL</sub> Digital low-level input current	Digital inputs			100	μA
V <sub>hys</sub> Digital input hysteresis	Digital inputs		0.45		V
T <sub>deg_nReset</sub> nReset input deglitch time		2.5		7.5	μs
T <sub>filt_ACONT</sub> A_CONT filter time <sup>(2)</sup>		30		70	μs
<b>Charge-pump VCP (CP = 0.1 μF to 0.47 μF, Cblk = 0.01 μF ±20%)</b>					
V <sub>O(CP)</sub> Output voltage	I <sub>LOAD</sub> = 0 mA, V <sub>M</sub> > 15 V	V <sub>M</sub> + 10		V <sub>M</sub> + 13	V
f(CP) Switching frequency			1.6		MHz

- (1) Deep Sleep shuts down majority of the device and runs minimal circuits (a few internal bias circuits and the nWAKEUP pin. Deep Sleep is entered by writing 1 to Setup Register, Bank 0, Bit 6. Device is restarted by pulling nWAKEUP pin low or power cycling V<sub>M</sub>. Deep Sleep functionality only available for V<sub>M</sub> > V<sub>thV<sub>M+</sub></sub>.
- (2) A\_CONT is filtered for both high and low levels.

**ELECTRICAL CHARACTERISTICS (continued)**
 $T_J = 0^\circ\text{C to } 135^\circ\text{C}$ ,  $V_M = 7\text{ V to } 38\text{ V}$  (unless otherwise noted)

PARAMETER		TEST CONDITIONS		MIN	TYP	MAX	UNIT
$t_{\text{start}}$	Start-up time	$C_{\text{Storage}} = 0.1\ \mu\text{F}$ ,	$V_M \geq 15\text{ V}$		0.5	2	ms
<b>V3p3 Output</b>							
$V_{3p3}$	Output voltage <sup>(3)</sup>			3	3.3	3.6	V
$C_{\text{bypass}}$	Output capacitor			0.08	0.1	10	$\mu\text{F}$
<b>Internal Clock OSCi</b>							
$f_{\text{OSCi}}$	System clock frequency			5.76	6.4	7.04	MHz
<b>CSELECT for DC-DC Startup Selection</b>							
$V_{\text{CS0}}$	dc-dc all off			0		0.3	V
$V_{\text{CS1}}$	Turn ON ODB	Pull down by external 200-k $\Omega$ resistor		1.3		2	V
$V_{\text{CS2}}$	Turn ON ODB then ODC	As pin open		3		3.6	V
<b>VLDO Regulator</b> <sup>(4)(5)(6)</sup>							
$V_{\text{LDOIN}}$	LDO input voltage			3		3.6	V
$V_{\text{LDOFB}}$	Feedback voltage				1		V
$V_{\text{LDOOUT}}$	Output voltage range			1		2.5	V
$I_{\text{OUT}}$	Load capability					500	mA
$I_{\text{OCP}}$	OCP current				725	1100	mA
$t_{\text{ideg}}$	OCP deglitch			3	8	13	$\mu\text{s}$
$V_{\text{ovp}}$	Overvoltage protection	% to nominal $V_{\text{outx}}$ detected at VFB (VFB increasing)		25	30	35	%
$V_{\text{uvp}}$	Undervoltage protection	% to nominal $V_{\text{outx}}$ detected at VFB (VFB decreasing)		-25	-30	-35	%
$t_{\text{vdeg}}$	UVP/OVP deglitch time			3	8	13	$\mu\text{s}$
$C_{\text{L1}}$	Load bypass configuration 1	Electrolytic load capacitance		27		120	$\mu\text{F}$
$C_{\text{ESR1}}$		ESR of load capacitance		0.05		2	$\Omega$
$C_{\text{C1}}$		Ceramic load capacitance		0		0.4	$\mu\text{F}$
$C_{\text{L2}}$	Load bypass configuration 2	Electrolytic load capacitance		80	100	120	$\mu\text{F}$
$C_{\text{ESR2}}$		ESR of load capacitance		0.05		0.2	$\Omega$
$C_{\text{C2}}$		Ceramic load capacitance		0		3	$\mu\text{F}$
<b>Three, DC-DC Converter</b> <sup>(7)</sup>							
$V_M \text{ OPE\_X}$	Operating supply voltage range ratio to $V_{\text{OUT}}$	$I_O < 0.6\text{ A}$	$V_{\text{th}} V_M < V_M < 7\text{ V}$			$0.8 \times V_M$	V
			$20\text{ V} < V_M < 38\text{ V}$			$0.9 \times V_M$	
ODx	Regulator output voltage	$20\text{ V} < V_M < 40\text{ V}$	$0 < T_J < 125$	-3	$V_O$	3	%
			$125 < T_J < 135$	-4	$V_O$	4	
		$6.5\text{ V} < V_M < 20\text{ V}$	-5	$V_O$	5		
		$V_M = 7\text{ V}, V_O = 5.5\text{ V}$	-5	$V_O$	5		
		$V_M = 7\text{ V}, V_O = 1\text{ V}$	$0 < T_J < 125$	-3	$V_O$	3	
			$125 < T_J < 135$	-4	$V_O$	4	
	$V_{\text{th}} V_M < V_M < 6.5\text{ V}, V_O \leq 3.3\text{ V}$	-5	$V_O$	5			
FBx	FBx pin voltage				1		V
$I_O \text{ ODx}$	Output current (DC)	$V_M > 15\text{ V}$				1.35	A
$I_O \text{ ODx2}$	Output current (DC) at low $V_M$	$V_M = 7\text{ V}, V_O = 5.5\text{ V}$				0.6	A

(3) V3p3 bypass pin is not meant to be used as a supply.

(4) LDO can be bypassed by either load configuration 1 or 2.

(5) Typical values for external components should be chosen such that when the tolerance is added to the typical, the values remain between the maximum and minimum specifications listed.

(6) When LDO is not used, recommend connecting VLDO\_IN to GND, VLDO\_OUT to GND, & VLDO\_FB to FB\_B.

(7)  $R_{\text{DS(on)}}$  at  $T = 135^\circ\text{C}$  guaranteed by characterization. Production test will be done at  $T = 25^\circ\text{C}/70^\circ\text{C}$ .

**ELECTRICAL CHARACTERISTICS (continued)**T<sub>J</sub> = 0°C to 135°C, V<sub>M</sub> = 7 V to 38 V (unless otherwise noted)

PARAMETER		TEST CONDITIONS	MIN	TYP	MAX	UNIT
I <sub>O</sub> OD <sub>x3</sub>	Output current (DC) at low V <sub>M</sub>	V <sub>M</sub> = 7 V, V <sub>O</sub> = 3.3 V			1.2	A
R <sub>DS(on)</sub> <sup>(7)</sup>	FET on-resistance at 0.8 A for OD <sub>x</sub> V <sub>M</sub> > 15 V	T <sub>J</sub> = 70 °C		0.85	1.05	Ω
		T <sub>J</sub> = 135 °C		1	1.2	
L	Inductor	V <sub>OUT</sub> = 1.0 V		150		μH
		V <sub>OUT</sub> ≥ 3.3 V		330		
C	Capacitor	V <sub>OUT</sub> = 1.0 V	270		330	μF
		V <sub>OUT</sub> ≥ 3.3 V		220		
<b>Three DC-DC Converter Protection</b>						
I <sub>O</sub> DD OD <sub>x</sub>	Overcurrent detect for OD <sub>x</sub> source	Peak current in each ON cycle	3		6	A
t <sub>ODXdeg</sub>	Cycle by cycle Idetect deglitch		100	200	400	ns
t <sub>ODXSD</sub>	dc-dc shutdown filter	Number of consecutive cycles with Idetect		4		chop cycles
V <sub>ovpx</sub>	Overvoltage protection	% to nominal V <sub>outx</sub> detected at VFB (VFB increasing)	25	30	35	%
V <sub>uvpx</sub>	Undervoltage protection	% to nominal V <sub>outx</sub> detected at VFB (VFB decreasing)	-25	-30	-35	%
t <sub>VXdeg</sub>	UVP/OVP deglitch time		3	8	13	μs
t <sub>sst</sub>	Start-up time with soft start				56	ms
V <sub>stover</sub>	Start-up overshoot	Ratio to V <sub>o</sub>			3	%
<b>V<sub>M</sub> Supervisory<sup>(8)</sup> (9)</b>						
V <sub>thV<sub>M-</sub></sub>	nORT, for V <sub>M</sub> low threshold	V <sub>M</sub> decreasing	4.5	5	6	V
V <sub>thV<sub>M+</sub></sub>	nORT, for V <sub>M</sub> high threshold	V <sub>M</sub> increasing	5.5	6	6.79	V
V <sub>thV<sub>Mh</sub></sub>	nORT, for V <sub>M</sub> detect hysteresis	V <sub>thV<sub>M+</sub></sub> - V <sub>thV<sub>M-</sub></sub>	0.5	1		V
V <sub>thV<sub>M2</sub></sub>	For motor driver off <sup>(10)</sup>				15	V
t <sub>V<sub>M</sub>filt</sub>	V <sub>th</sub> V <sub>M</sub> monitor filtering time	For V <sub>th</sub> V <sub>M</sub> detect	4		30	μs
t <sub>V<sub>M2</sub>filt</sub>	V <sub>th</sub> V <sub>M2</sub> monitor filtering time	For V <sub>th</sub> V <sub>M2</sub> detect	30		60	ms
<b>Thermal Shutdown: TSD<sup>(11)</sup> (12)</b>						
T <sub>TSD</sub>	Thermal shutdown set points		150	170	190	°C
t <sub>TSDdeg</sub>	TSD deglitch time		30	60	90	μs
<b>Temperature Warning: Pre-TSD<sup>(13)</sup> (12)</b>						
PreTSD	Temperature warning	Assert at TH_OUT pin	115	135	155	°C
<b>Open-drain outputs (nORT, Logic_OUT, TH_OUT)</b>						
V <sub>OH</sub>	High-state voltage	RL = 1 kΩ to 3.3 V	3			V
V <sub>OL</sub> <sup>(14)</sup>	Low-state voltage	RL = 1 kΩ to 3.3 V			0.3	V
I <sub>OL</sub> <sup>(14)</sup>	Low-state sink current	V <sub>o</sub> = 0.25 V	2			mA
t <sub>r</sub> <sup>(15)</sup>	Rise time	10% to 90%			1	μs
t <sub>f</sub> <sup>(15)</sup>	Fall time	90% to 10%			50	ns

(8) V<sub>M</sub> must be V<sub>M</sub> > V<sub>thV<sub>M+</sub></sub> to start up internal dc-dc converter.(9) When V<sub>M</sub> goes down below V<sub>thV<sub>M+</sub></sub>, the VUVP<sub>x</sub> (undervoltage protection in dc-dc) are masked. The dc-dc converter is shut off by nORT assertion at V<sub>thV<sub>M-</sub></sub>.(10) No nORT assertion to V<sub>thV<sub>M2</sub></sub> detection.

(11) TSD does not need thermal hysteresis.

(12) Parametric specified by characterization. Not production tested.

(13) PreTSD does not need thermal hysteresis.

(14) Production test only measures Vol and Iol to ensure timing.

(15) t<sub>r</sub> and t<sub>f</sub> dominated by external capacitance, pullup resistance, and open-drain NMOS R<sub>DS(on)</sub>.



**ELECTRICAL CHARACTERISTICS (continued)**
 $T_J = 0^\circ\text{C to } 135^\circ\text{C}$ ,  $V_M = 7\text{ V to } 38\text{ V}$  (unless otherwise noted)

PARAMETER		TEST CONDITIONS	MIN	TYP	MAX	UNIT
<b>nORT Delay: Startup Sequence</b> <sup>(16)</sup> <sup>(17)</sup>						
Tord1	nORT delay 1	Reset deassertion from $V_{th_{VM+}}$ dc-dc wake failing	200	300	390	ms
Tord3	dc-dc turn on delay	From one dc-dc wake up to following dc-dc to go soft-start sequence	5	10	15	ms
Tord4	nORT delay 4	Reset deassertion from 2nd dc-dc wake up	60	120	180	ms
<b>nReset Input</b> <sup>(16)</sup>						
Treset	nReset assertion to nORT assertion delay	nReset falling to nORT failing		5	10	$\mu\text{s}$
<b>H-Bridge Drivers (OUTX+ and OUTX-) Condition: <math>V_M = 15\text{ V to } 38\text{ V}</math></b> <sup>(18)</sup>						
$I_{OUT1(max)}$	Peak output current 1	Less than 500-ns period			6.8	A
$I_{OUT2(max)}$	Peak output current 2	Less than 100-ms period			2.42	A
$R_{DSON}$	FET ON resistance at 0.8 A	$T_J = 70^\circ\text{C}$ $T_J = 135^\circ\text{C}$		0.55 0.7	0.65 0.85	$\Omega$
$I_{CEX}$	Output leakage current	$V_{OUTX} = 0\text{ V or } 10$			10	$\mu\text{A}$
$I_{OC\ Motor}$	Motor overcurrent threshold for each H-bridge <sup>(18)</sup>		3		8	A
Fchop	Motor chopping frequency = FOSCM/8		90	100	110	kHz
<b>DC Motor Drivers</b>						
$t_r$	Rise time	$V_M = 35\text{ V}$ 20% to 80%	50		200	nS
$t_f$	Fall time	$V_M = 35\text{ V}$ 20% to 80%	50		200	nS
$t_{PDOFF}$	Enable or strobe detection to sink or source gate OFF delay		50	150	400	nS
$t_{COD}$	Crossover delay time to prevent shoot through		<sup>(19)</sup> 100	600	1000	nS
$t_{PDON}$	Enable or strobe detection to sink or source gate ON delay			750		nS
$t_{ideg}$	MISD BLANK	[00] <sup>(20)</sup>	1.80	2.25	2.95	$\mu\text{s}$
		[01] <sup>(21)</sup>	1.20	1.50	2.30	
		[10] <sup>(22)</sup>	2.35	3.00	3.65	
		[11] <sup>(23)</sup>	2.95	3.75	4.30	
$T_{blank}$	TBLANK	[00] <sup>(24)</sup>	3.05	3.45	5.50	$\mu\text{s}$
		[01] <sup>(25)</sup>	1.90	2.20	4.15	
		[10] <sup>(26)</sup>	4.15	4.70	6.75	
		[11] <sup>(27)</sup>	5.30	5.95	8.25	

(16) This includes asynchronous timing deviation between the event to the timer clock.

(17) nORT assertion delay is configurable and defined in the serial register section.

(18) When the overcurrent is detected, all the H-bridges are shut down and assert nORT per shutdown configuration.

(19)  $t_{COD}$ ,  $P_{minp}$ , and  $P_{mine}$  not production tested.

(20) 3 to 4 periods  $Fosc/4 + 1\text{ Fosc}$

(21) 2 to 3 periods  $Fosc/4 + 1\text{ Fosc}$

(22) 4 to 5 periods  $Fosc/4 + 1\text{ Fosc}$

(23) 5 to 6 periods  $Fosc/4 + 1\text{ Fosc}$

(24) 3  $Fosc/8$  (can add up to 1 additional  $Fosc/8 + 1.5\text{ Fosc}$  at phase or enable change due to asynchronous ambiguity)

(25) 2  $Fosc/8$  (can add up to 1 additional  $Fosc/8 + 1.5\text{ Fosc}$  at phase or enable change due to asynchronous ambiguity)

(26) 4  $Fosc/8$  (can add up to 1 additional  $Fosc/8 + 1.5\text{ Fosc}$  at phase or enable change due to asynchronous ambiguity)

(27) 5  $Fosc/8$  (can add up to 1 additional  $Fosc/8 + 1.5\text{ Fosc}$  at phase or enable change due to asynchronous ambiguity)

**ELECTRICAL CHARACTERISTICS (continued)**

T<sub>J</sub> = 0°C to 135°C, V<sub>M</sub> = 7 V to 38 V (unless otherwise noted)

PARAMETER		TEST CONDITIONS	MIN	TYP	MAX	UNIT
VRS <sub>TRIP</sub>	Internal current trip	00	1.18	1.4	1.62	A
		01	1.48	1.7	1.92	
		10	1.68	1.9	2.12	
		11	1.98	2.2	2.42	
	External resistor sense voltage trip threshold	00	165	185	205	mV
		01	190	210	230	
		10	240	260	280	
		11	290	310	330	
P <sub>minp</sub>	Minimum pulse width (phase)	(19)			1	μs
P <sub>mine</sub>	Minimum pulse width (enable)	(19)			1	μs
<b>Serial Interface</b> <sup>(28)</sup>						
f(CLK)	Clock frequency				25	MHz
t <sub>wh</sub> (CLK)	Minimum high-level pulse width		10			ns
t <sub>wl</sub> (CLK)	Minimum low-level pulse width		10			ns
t <sub>dcs</sub>	Setup time, DATA to CLK↓		10			ns
t <sub>dch</sub>	Hold time, CLK↓ to DATA		10			ns
t <sub>dss</sub>	Setup time, DATA to STROBE↑		10			ns
t <sub>dsh</sub>	Hold time, STROBE↑ to DATA		10			ns
t <sub>css</sub>	Setup time, CLK↓ to STROBE↑		(29)20			ns
t <sub>csh</sub>	Hold time, STROBE↑ to CLK↓	(29)	20			ns
t <sub>nss</sub>	Setup time, nSLEEP↓ to STROBE↑		(30)4			μs
t <sub>nsh</sub>	Hold time, STROBE↑ to nSLEEP↑		10			ns
t <sub>w</sub> (STRB)	Minimum strobe pulse width		20			ns
<b>Serial Interface: ID Monitor Function at Logic_out Pin, Extended Setup Mode</b> <sup>(31)</sup>						
t <sub>ODL</sub>	0 data output delay bit 3 to 0 (ext-setup) = (1100)	From strobe rise to Logic_out (1 kΩ to external 3.3 V)			4000	ns
t <sub>ODH</sub>	1 data output delay bit 3 to 0 (ext-setup) = (1111)				4000	ns

(28) Serial interface timing will not be tested parametrically in production.

(29) DATA value at STROBE is address bit for Setup and Extended Setup register so setup and hold times apply to DATA relative to STROBE. CLK and DATA also require setup and hold times relative to each other. Therefore, CLK and STROBE setup and hold timing is the summation of both.

(30) Internal filter on nSLEEP to STROBE drives this specification.

(31) Serial interface timing will not be tested parametrically in production.

**Serial Interface**

The device has a serial interface port (SIP) circuit block to control dc motor H-bridges, dc-dc regulators, and other functions, such as blanking time, OFF time, etc. Since the SIP shares its three lines with three of the motor control signals, the SIP is only available when nSLEEP is low.

**Table 1. Serial Interface**

nSLEEP	PIN 9	PIN 10	PIN 14	SIP FUNCTIONALITY
L	STB	CLK	DATA	Yes
H	ENA	PHA	PHC	No

Sixteen-bit serial data is shifted least significant bit (LSB) first into the serial data input (DATA) shift register on the falling edge of the serial clock (CLK). After 16-bit data transfer, the strobe signal (Strobe) rising edge latches all the shifted data. During the data transferring, Strobe voltage level is ok with L level or H level.

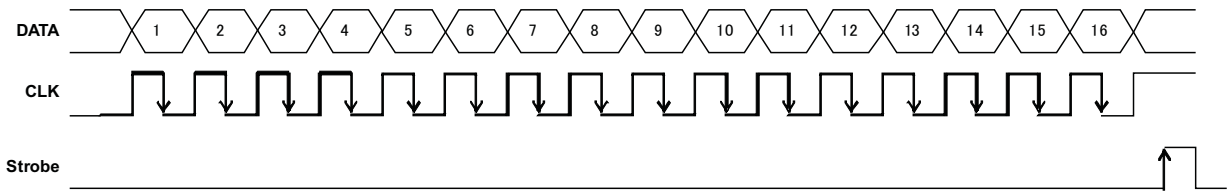

**NOTE**

During startup (VM rising), nSLEEP input is set HI, suppressing false data latching caused by a rising edge on the STB signal. nSLEEP will remain HI until nORT is released (120 ms after dc-dc regulators come up).

**Setup Mode, Extended Setup Mode, Power-Down Mode**

The motor output mode is configured through the SIP (DATA, CLK and STROBE) when nSLEEP = L. After set up, the nSLEEP pin must be pulled high for normal motor drive control. The value on the DATA line at the positive edge of STROBE when nSLEEP is low, selects whether the data is written to the Setup or Extended Setup registers. Setup is selected for DATA = L; Extended Setup is selected for DATA = H.

The condition, which the device requires for set up (initialize), is after the nORT (Reset) output goes H level from L level (power on, recovery from  $V_M < 7\text{ V}$ ). During nSLEEP in L level, all the motor-drive functions are shut down and their outputs are high-impedance state. This device forces motor-driver functions to shut down for the power-down mode, and is not damaged even if nSLEEP is asserted during motor driving.

Data is shifted at all times, regardless of nSLEEP. Care must be taken to ensure valid data has been shifted into the internal shift register, before the STROBE rising edge, occurs while nSLEEP is LO.

nSLEEP = L (Bit 16 = L): Setup Mode

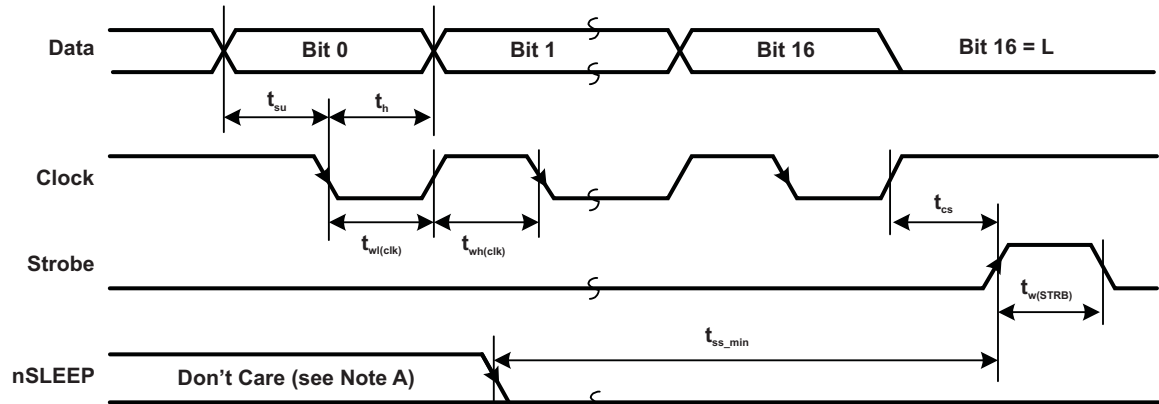

nSLEEP = L (Bit 16 = H): Extended Setup Mode

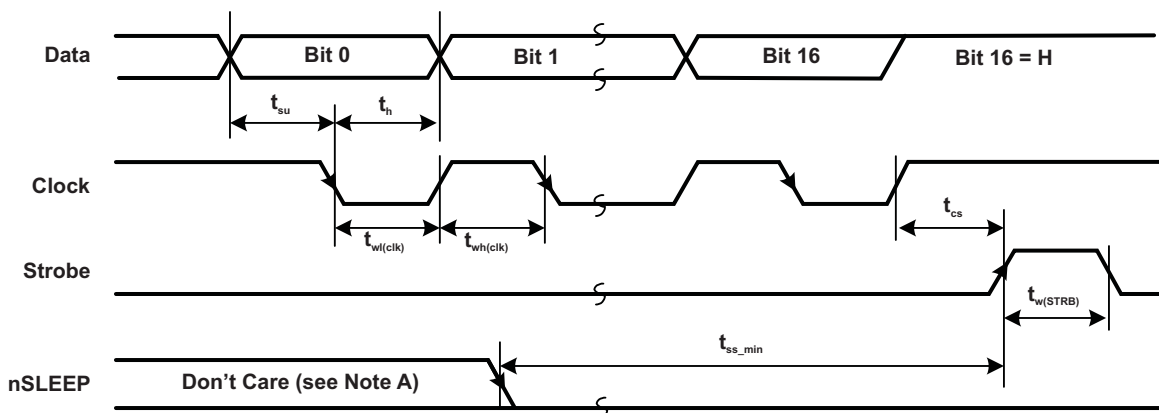

A. For initial setup, nSleep state can be "Don't care" before the tss\_min timing prior to the strobe.

Figure 3. Serial Interface Timing

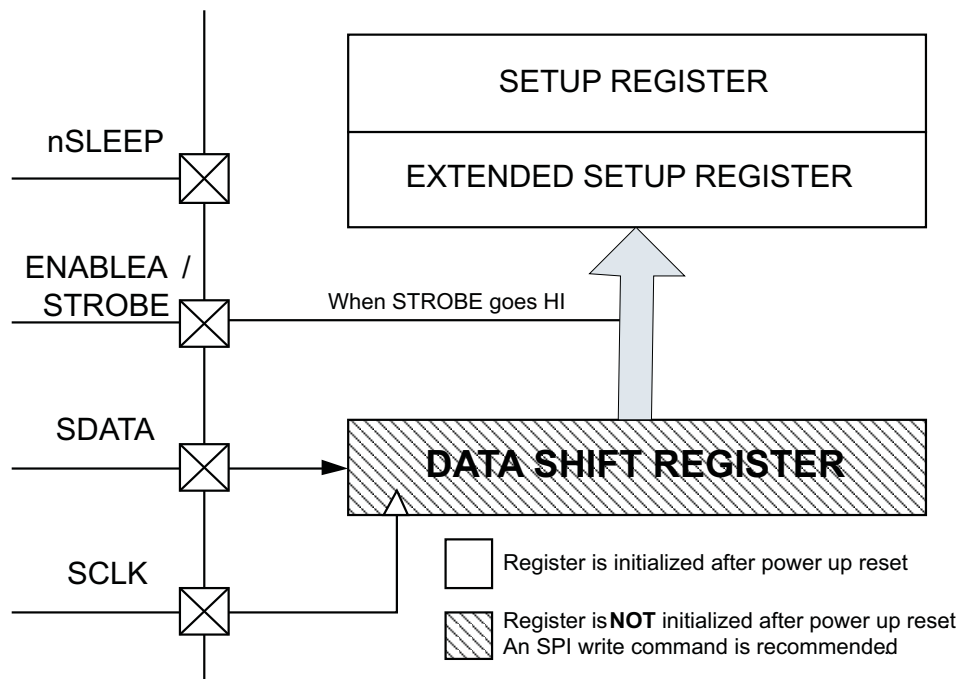

- A. It is recommended that after initial power up sequence, a serial command be performed to clear undefined data in the internal shift register. This will help avoid latching undefined data into SETUP and EXTENDED SETUP registers. SETUP and EXTENDED SETUP registers are properly initialized during power up, but internal shift register is not initialized.

**Figure 4. Serial Peripheral Interface Block Diagram**

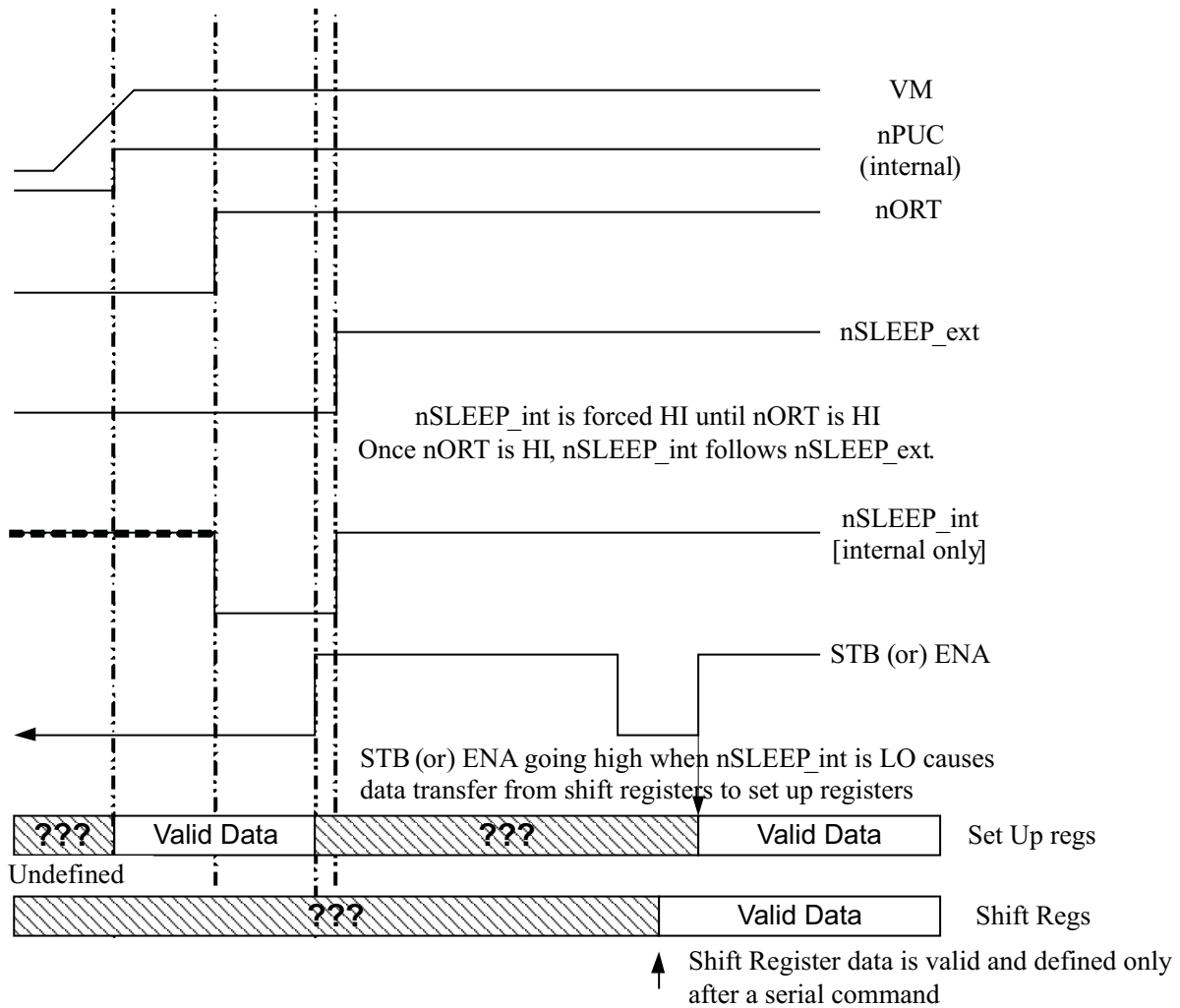

- A. During startup (VM rising), internally nSLEEP de-asserted to HI, suppressing false data latching caused by a rising edge on the STB signal. nSLEEP will remain HI until nORT is released (120 ms after dc-dc regulators come up).

**Figure 5. Serial Peripheral Interface STROBE Blocking During Power Up**

**Operation Setup Register Bit Assignment**
**Table 2. Setup Registers (1) (2) (3)**

BANK	BIT	FUNCTION	DEFAULT	COMMENT
0	0	Tblank A 0	0	00: 3.75 $\mu$ s, 01: 2.50 $\mu$ s 10: 5.00 $\mu$ s, 11: 6.25 $\mu$ s
	1	Tblank A 1	0	
	2	Tblank B 0	0	00: 3.75 $\mu$ s, 01: 2.50 $\mu$ s 10: 5.00 $\mu$ s, 11: 6.25 $\mu$ s
	3	Tblank B 1	0	
	4	Tblank C 0	0	00: 3.75 $\mu$ s, 01: 2.50 $\mu$ s 10: 5.00 $\mu$ s, 11: 6.25 $\mu$ s
	5	Tblank C 1	0	
	6	DC-DC A Minoff Time	0	0: 2.2 $\mu$ s, 1: 6.6 $\mu$ s
	7	DC-DC A SW	1	0: On 1: Off
	8	DC-DC B SW	CSELECT	
	9	DC-DC C SW	CSELECT	
	10	MOTOR CHOPPING 0	0	00: 100 kHz, 01: 50 kHz 10: 133 kHz, 11: 200 kHz
	11	MOTOR CHOPPING 1	0	
	12	RESET DELAY CONTROL	0	0: Disable, 1: Enable
	13	LDO ENABLE	Note 1	0: On, 1: Off
	14	DC-DC B Minoff Time	0	0: 2.2 $\mu$ s, 1: 6.6 $\mu$ s
15	Bank Change	0	0: Bank0, 1: Bank1	
1	0	MISD BLANK AB 0	0	00: 2.25 $\mu$ s, 01: 1.50 $\mu$ s 10: 3.00 $\mu$ s, 11: 3.75 $\mu$ s
	1	MISD BLANK AB 1	0	
	2	MISD BLANK C 0	0	00: 2.25 $\mu$ s, 01: 1.50 $\mu$ s 10: 3.00 $\mu$ s, 11: 3.75 $\mu$ s
	3	MISD BLANK C 1	0	
	4	VRS A	0	0: Disable, 1: Enable
	5	VRS A Level 0	0	VRSA = 0: 00: 1.4 A, 01: 1.7 A 10: 1.9 A, 11: 2.2 A
	6	VRS A Level 1	0	VRSA = 1: 00: 185 mV, 01: 210 mV 10: 260 mV, 11: 310 mV
	7	DC-DC C Minoff Time	0	0: 2.2 $\mu$ s, 1: 6.6 $\mu$ s
	8	VRS B	0	0: Disable, 1: Enable
	9	VRS B Level 0	0	VRSB = 0: 00: 1.4 A, 01: 1.7 A 10: 1.9 A, 11: 2.2 A
	10	VRS B Level 1	0	VRSB = 1: 00: 185 mV, 01: 210 mV 10: 260 mV, 11: 310 mV
	11	DEEP SLEEP	0	0: Disable, 1: Enable
	12	VRS C	0	0: Disable, 1: Enable
	13	VRS C Level 0	0	VRSC = 0: 00: 1.4 A, 01: 1.7 A 10: 1.9 A, 11: 2.2 A
	14	VRS C Level 1	0	VRSC = 1: 00: 185 mV, 01: 210 mV 10: 260 mV, 11: 310 mV
15	Bank Change	0	0: Bank0, 1: Bank1	

(1) The LDO default follows the DC/DC B default value based on CSELECT.

(2) All bits go to default for  $V_M < V_{thVM}$ , nReset = L.

(3) RESET DELAY CONTROL set to 1 delays nORT assertion by 100  $\mu$ s typical. Range is 85  $\mu$ s to 125  $\mu$ s.

Operation Extended Setup Register Bit Assignment

**Table 3. Extended Setup Register** <sup>(1) (2)</sup>

BANK	BIT	FUNCTION	DEFAULT	COMMENT
NA	0	Signal Select 0	0	See Logic_Out Table
	1	Signal Select 1	0	
	2	Signal Select 2	0	
	3	Signal Select 3	0	
	4	DCDC/LDO ISD Mask	0	0: Disable, 1: Enable
	5	DCDC/LDO VSD Mask	0	0: Disable, 1: Enable
	6	Motor ISD Mask	0	0: Disable, 1: Enable
	7	TSD Mask	0	0: Disable, 1: Enable
	8	Reset Mask C	0	0: Disable, 1: Enable
	9	Reset Mask B	0	0: Disable, 1: Enable
	10	Reset Mask A	0	0: Disable, 1: Enable
	11	Reset Mask SR	0	0: Disable, 1: Enable
	12	Pre TSD	0	0: TSD-20C, 1: Analog output
	13	TSD Cont0	0	See TSD Control Table
	14	TSD Cont1	0	
	15	MISD Cont	0	See MISD Control Table

(1) All bits go to default for  $V_M < V_{th_{VM-}}$ , nReset = L.

(2) Bits [11:8] are selective shutdown bits. Setting to a 1 makes faults on the associated regulator only shutdown that regulator and allows restart on an nSLEEP L > H transition. Setting to 0 shuts everything down and restarts only for  $V_M < V_{th_{VM-}}$  or nReset = L.

**Table 4. TSD Control – Operation After Detected TSD**

TSD Cont1	TSD Cont0	DC-DC	MOTORS	nORT	LDO	RELEASED BY
0	0	OFF	OFF	LOW	OFF	$V_M < V_{th_{VM-}}$ or nReset = L
0	1	ON	OFF	HIGH	ON	$V_M < V_{th_{VM-}}$ or nReset = L or nSLEEP L > H transition
1	0	ON	OFF	PULSE	ON	$V_M < V_{th_{VM-}}$ or nReset = L or nSLEEP L > H transition
1	1	OFF	OFF	LOW	OFF	$V_M < V_{th_{VM-}}$ or nReset = L

**Table 5. MISD Control – Operation After Detected Motor OCP**

MISD Cont	DC-DC	MOTORS	nORT	LDO	RELEASED BY
0	ON	OFF	PULSE <sup>(1)</sup>	ON	$V_M < V_{th_{VM-}}$ or nReset = L or nSLEEP L > H transition
1	OFF	OFF	LOW	OFF	$V_M < V_{th_{VM-}}$ or nReset = L

(1) PULSE in Control Tables is 40-ms duration.



Table 6. Logic\_Out

SIGNAL SELECT	FUNCTION (Logic_out OUTPUT)
0000	Detect OCP/UVP/OVP on A, output L
0001	Detect OCP/UVP/OVP on B, output L
0010	Detect OCP/UVP/OVP on C, output L
0011	Detect OCP on DC-DC/LDO regulator, output L
0100	Detect UVP, output L
0101	Detect OVP, output L
0110	Detect OCP on motor, output L
0111	Detect TSD, output L
1000	Revision code bit 0
1001	Revision code bit 1
1010	Revision code bit 2
1011	Device code bit 0
1100	Device code bit 1
1101	N/A
1110	Detect OCP/UVP/OVP on LDO regulator, output L
1111	Fix, output H

### Deep Sleep Mode

Deep sleep mode can be entered by setting the deep sleep bit (bit 11) on the Setup register to HI. Once deep sleep mode is entered, every single subsystem is disabled, except the block necessary to regain power by making the nWAKEUP input pin LO.

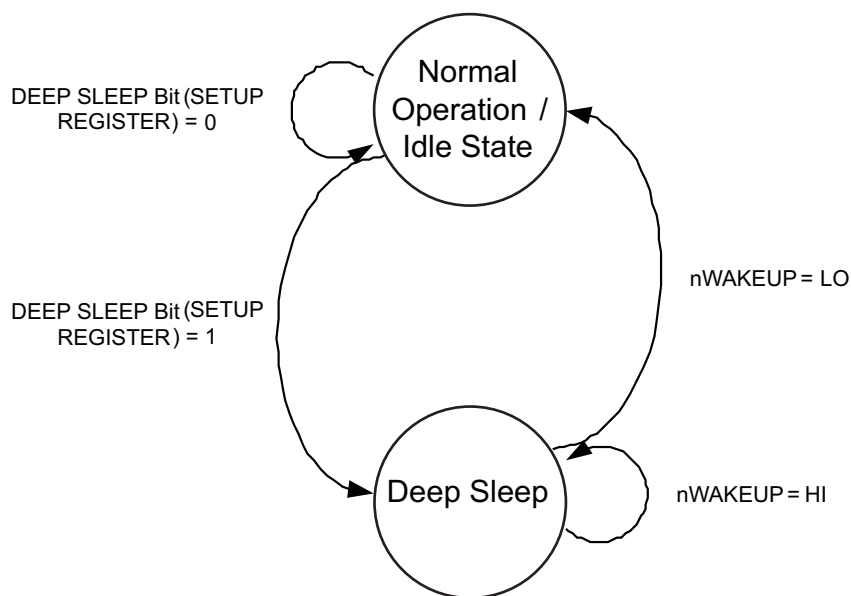

Figure 6. Deep Sleep Mode

**DC Motor Drive**

H-bridges A, B, and C can be controlled by using the ENABLE\_X and PHASE\_X control lines.

The H-bridge driver operation is available for  $V_M > 15\text{ V}$ .

Internal current sense functionality is present by default. External sensing can be enabled through the serial interface. If enabled, the sense resistor must be placed externally.

**NOTE**

A capacitor, not larger than 2200 pF, can be placed between each H-bridge output to GND for EMI suppression purposes. It will increase the peak current but will have no impact on the operation.

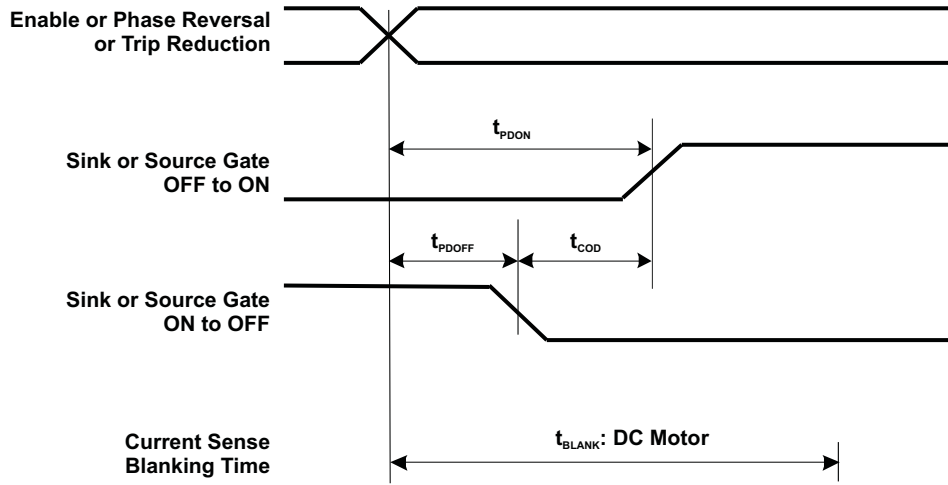

**Figure 7. Crossover and Blanking Timing for H-Bridge**

The dc motor H-bridges include a tBLANK period to ignore huge current spike due to rush current to varistor capacitance.

**Short/Open for Motor Outputs**

When a short/open situation happens, the protection circuit prevents device damage under certain conditions (short at start-up, etc).

Shutdown is released based on MISD Control in the Extended Setup register.

**Table 7. DC Motor-Drive Truth Table <sup>(1)</sup>**

FAULT CONDITION	nSleep	Enablex	Phasex	+ HIGH SIDE	+ LOW SIDE	- HIGH SIDE	- LOW SIDE
0	0	X	X	OFF	OFF	OFF	OFF
0	1	0	X	OFF	OFF	OFF	OFF
0	1	1	0	OFF	ON	ON	OFF
0	1	1	1	ON	OFF	OFF	ON
Motor OCP	X	X	X	OFF	OFF	OFF	OFF
TSD	X	X	X	OFF	OFF	OFF	OFF

(1) X = Don't care

## Charge Pump

The charge-pump voltage generator circuit utilizes, external storage, and bucket capacitors. It provides the necessary voltage to drive the high-side switches, for both dc-dc regulators and motor driver. The charge-pump circuit is driven at a frequency of 1.6 MHz (nom). Recommended bucket capacitance (connected from CP1 to CP2) is 10 nF, rated at 55 V (minimum), and storage capacitance is 0.1  $\mu$ F, at 16 V (minimum). The charge-pump storage capacitor, Cstorage, should be connected from the CP output to  $V_M$ .

For power save in sleep mode, the charge pump is stopped when N\_SLEEP = L and all three regulators are turned OFF. When the part is powered up, the charge pump is started first after the CSELECT capture and, 10 ms later from the CP startup, the first regulator is started up.

**Table 8. Charge Pump** <sup>(1)</sup> <sup>(2)</sup>

FAULT CONDITION	DC-DC Ch-A	DC-DC Ch-B	DC-DC Ch-C	nSleep	CHARGE PUMP
X	OFF	OFF	OFF	0	OFF
X	ON	X	X	X	ON
X	X	ON	X	X	ON
X	X	X	ON	X	ON
0	X	X	X	1	ON
Motor OCP	X	X	X	1	ON
TSD	OFF	OFF	OFF	X	OFF

(1) X = Don't care

(2) DC=DC status in fault condition is determined by serial register settings, TSD Control table, and MISD Control table. These tables define status of charge pump.

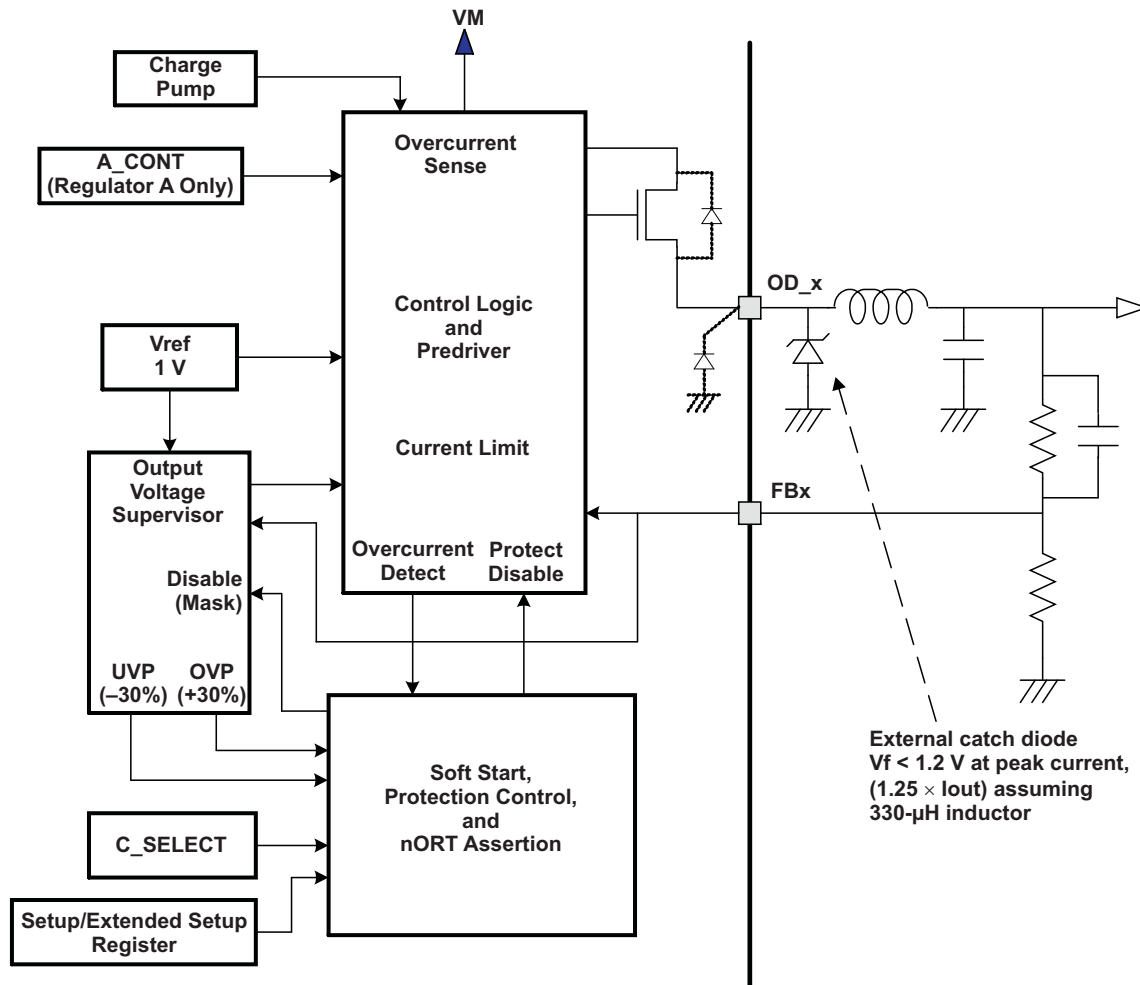

Figure 8. DC-DC Converter

This is a switch-mode regulator with integrated switches, to provide a programmed output set by the feedback terminal. The dc-dc converter has a variable duty cycle topology. External filtering (inductor and capacitor) and external catch diode are required. The output voltage is short circuit protected.

The regulator has a soft-start function to limit the rush current during start-up. It is achieved by using VFB ramp during soft start.

For unused dc-dc converter channels, the external components can be removed if the channel is set to inactive by the CSELECT pin and register bits. Recommend connecting unused FB pin to GND or V3p3 (pin 17).

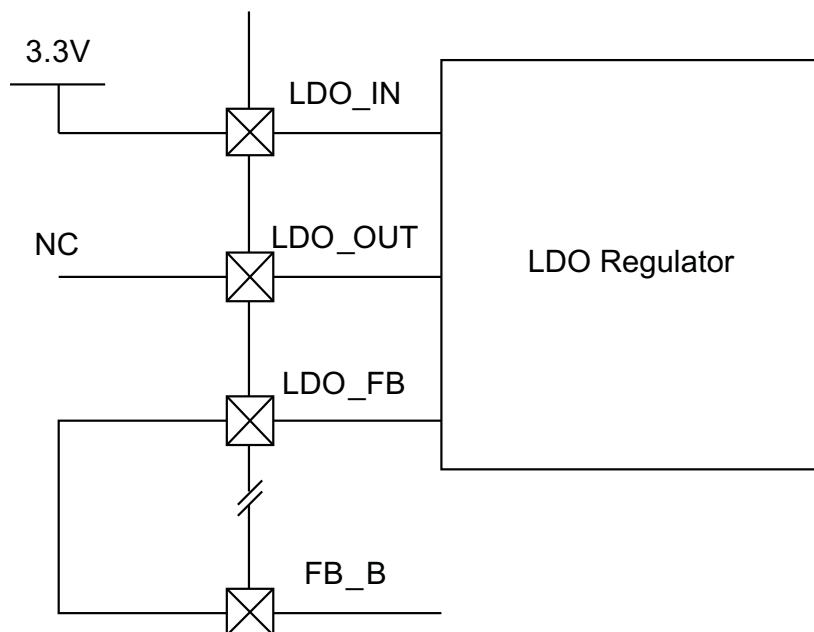

Figure 9. Unused LDO Recommended Connections

For proper termination, it is recommended that, if left unused, the LDO terminals be connected in the following fashion:

1. LDO IN must be powered by an input voltage greater than 1 V.
2. LDO OUT must be left disconnected.

LDO Feed Back must be connected to the DC/DC Converter Channel B Feed Back terminal.

Table 9. CSELECT for Start-Up <sup>(1)</sup> <sup>(2)</sup> <sup>(3)</sup>

CSELECT	PIN VOLTAGE	DCDC_A	DCDC_B	DCDC_C
Gnd	0 V to 0.3 V	OFF	OFF	OFF
Pull down (by external 200 kΩ)	1.3 V to 2.0 V	OFF	ON	OFF
OPEN	3.0 V to 3.3 V	OFF	ON	ON

- (1) The CSELECT pin is connected to internal 3.3-V supply through 200-kΩ resistor.
- (2) This CSELECT pin control is valid after the PowerON Reset is initiated. Once the Setup Register is set, the dc-dc control follows the bits 7 to 9 on the Setup Register, bank 0, until the next PowerON Reset event occurred.
- (3) For OPEN case, B starts up 1st and C follows after 10-ms delay.

Table 10. Regulator A Control

SETUP REGISTER BANK 0, BIT 7	A_CONT	DCDC_A
0	0	ON
0	1	OFF
1	0	OFF
1	1	OFF

### nReset: Input for System Reset

nReset pin assertion stops all the dc-dc converters and H-bridges. It also resets all the register contents to default values. After deassertion of input, device follows the initial start-up sequence. The CSELECT state is captured after the nReset deassertion (L > H).

The input is pulled up to internal 3.3 V by a 200-kΩ resistor. When the pin is H or left open, the reset function is released. Also it has deglitch filter of 2.5 μs to 7.5 μs.

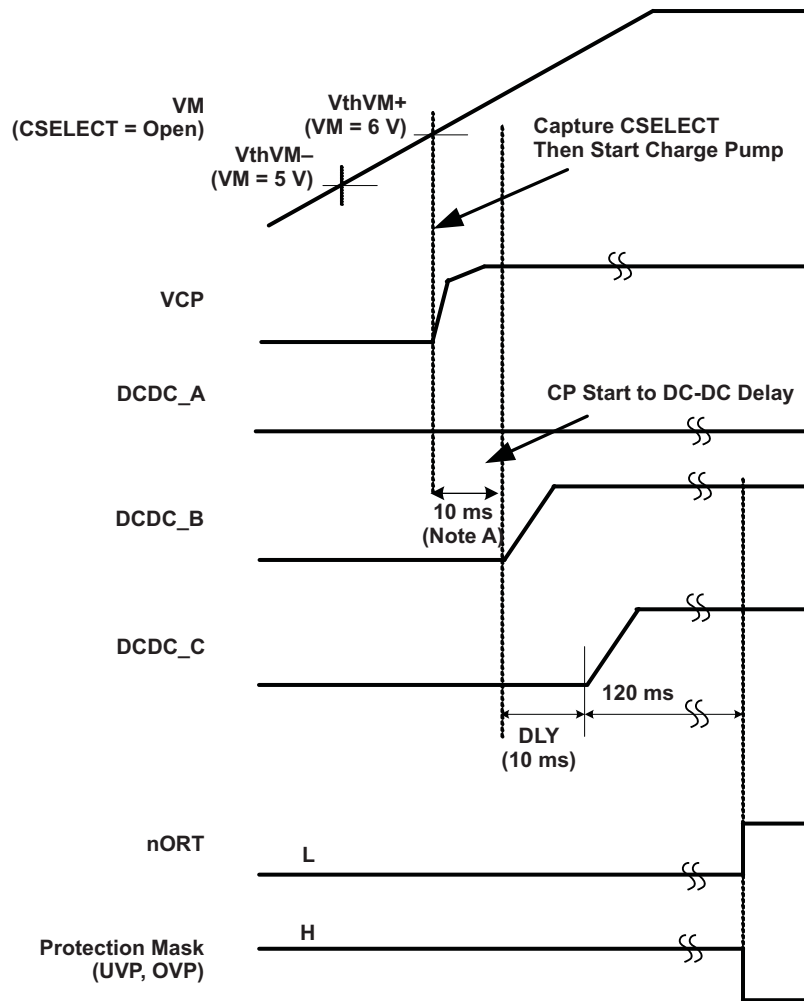

- A. Charge-pump wakeup delay, from 10 ms to 20 ms due to asynchronous event capture.
- B. When  $V_M$  crosses the  $V_{thVM+}$  (about 6.0 V), the CSELECT state is captured. In case of the CSELECT being open (pulled up to internal 3.3 V), dc-dc regulator channels B and C are turned on.
- C. LDO OCP is masked during protection mask time.
- D. In order to avoid false SPI data latching caused by a rising edge on the STB signal, nSLEEP will remain high during the power up stage (VM rising) and until nORT is released.
- E. DC/DC Channel A follows the Regulator A Control table. During power up, DC/DC Channel A starts up disabled (SETUP BANK 0 [7] = 1).

**Figure 10. Power-up Timing (Power up With DC-DC Turn on by CSELECT)**

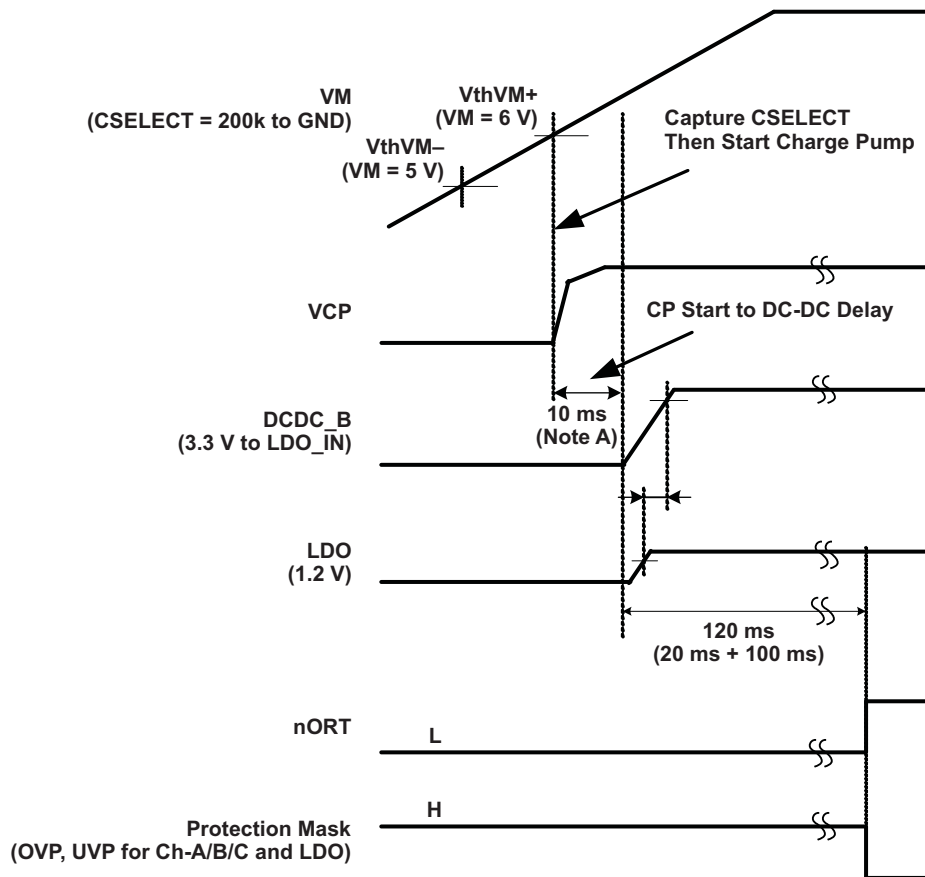

- A. Charge-pump wakeup delay, from 10 ms to 20 ms due to asynchronous event capture.
- B. LDO Enable follows DC/DC B Enable during power up and can be controlled using the SETUP register after power up.

**Figure 11. Power-up Timing (Power up With LDO, Supplied by DCDC\_B)**

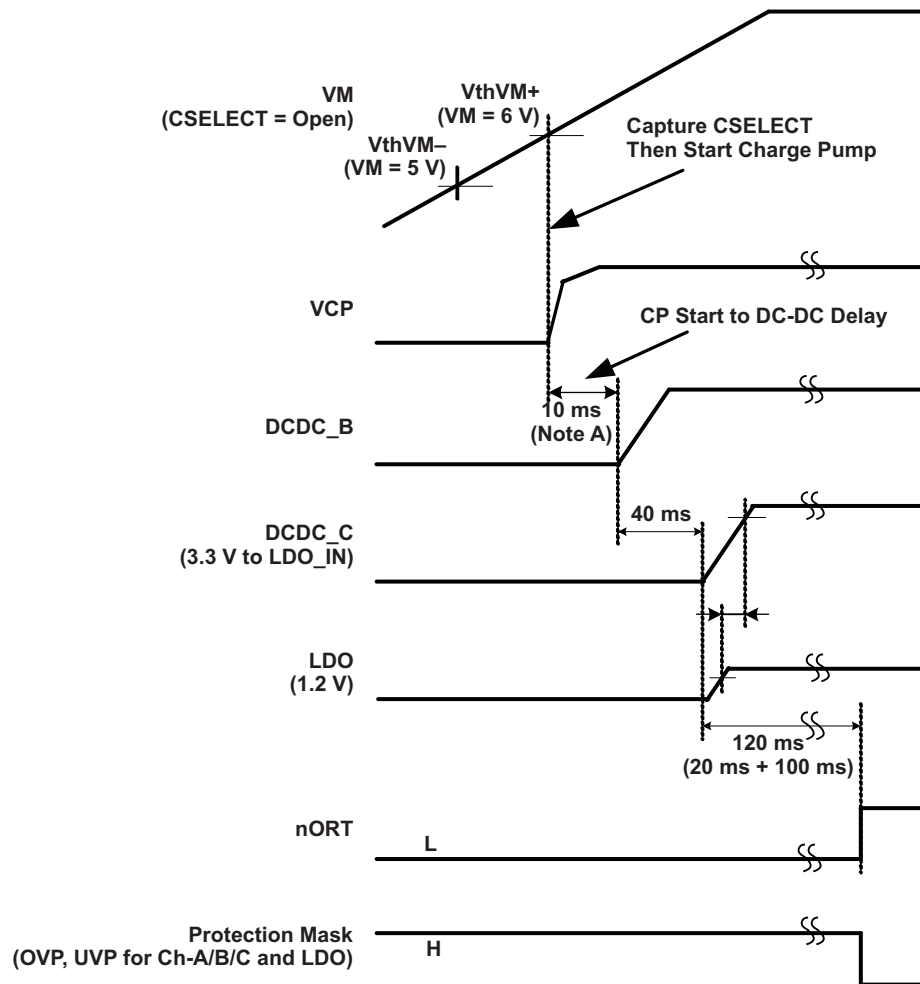

- A. Charge-pump wakeup delay, from 10 ms to 20 ms due to asynchronous event capture.
- B. LDO Enable follows DC/DC B Enable during power up and can be controlled using the SETUP register after power up. In this case, since LDO\_IN is driven by DC/DC Channel C, LDO\_OUT will follow DC/DC Channel C.

**Figure 12. Power-up Timing (Power up With LDO, Supplied by DCDC\_C)**



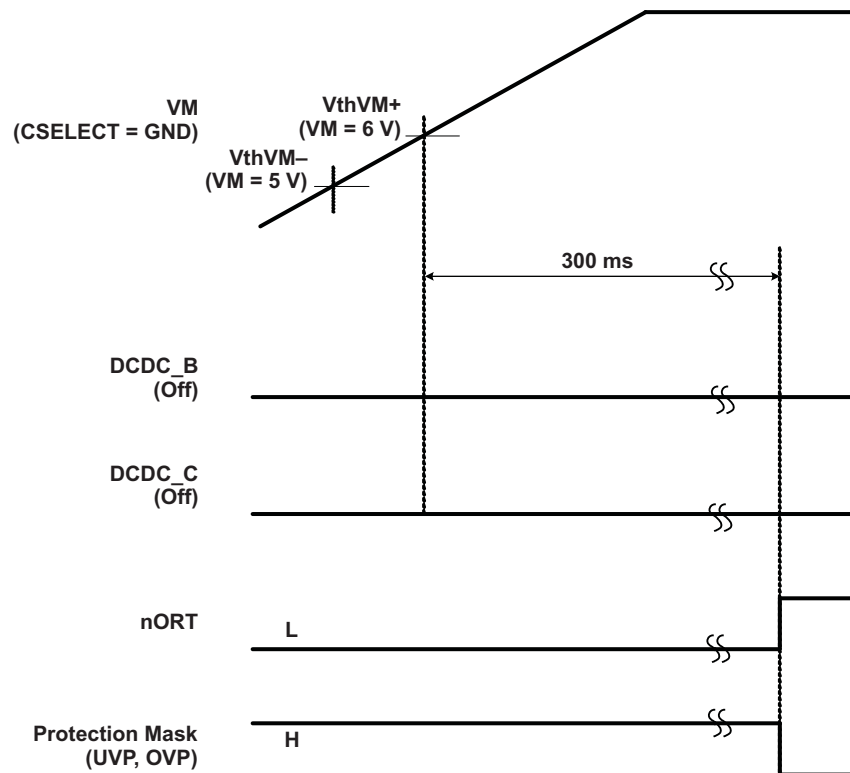

- A. When  $V_M$  crosses the  $V_{thVM+}$  (about 6 V) with CSELECT = GND, none of three regulators are turned ON. The nORT output is released to H after 300 ms from  $V_{thVM+}$  crossing.
- B. LDO OCP is masked during protection mask time.

**Figure 13. Power-up Timing (Power up Without DC-DC Turn on, CSELECT = GND)**

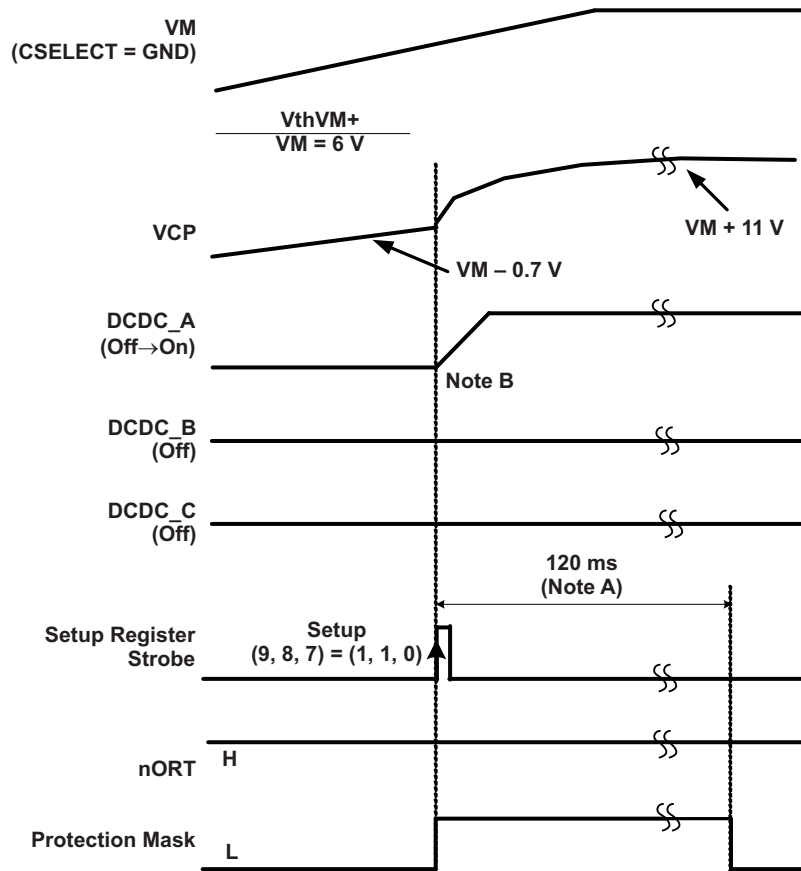

- A. The regulator is started from the strobe input, same as the charge pump. No 10-ms waiting, because the VCP pin already reached to  $V_M - 0.7V$ .
- B. LDO OCP is masked during protection mask time.
- C. A\_CONT must be LOW or OPEN for regulator A to turn on.

**Figure 14. Power-up Timing (DC-DC Regulator Wakeup by Setup Register)**

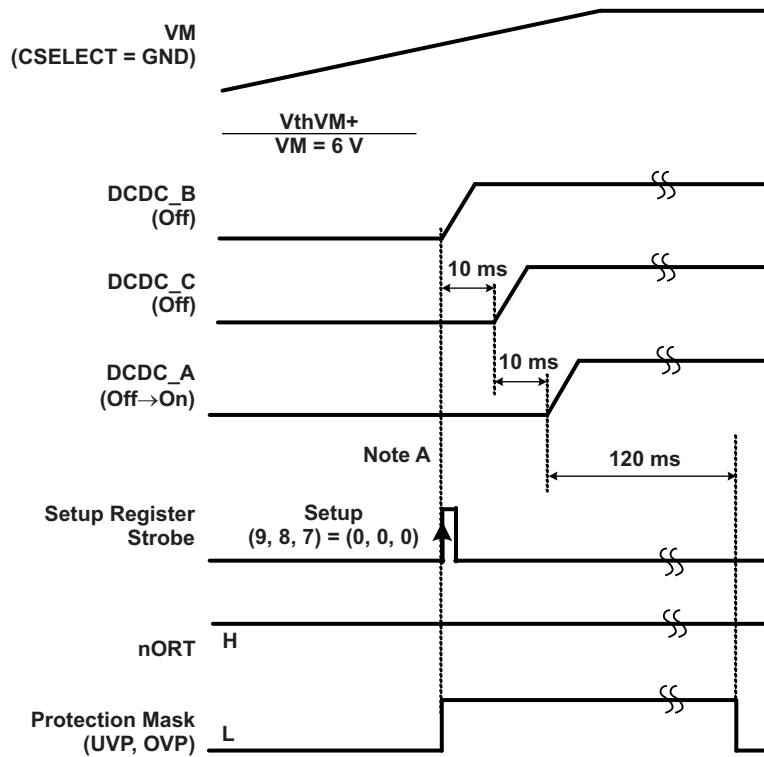

- A. A\_CONT must be LOW or OPEN for regulator A to turn on.
- B. LDO OCP is masked during protection mask time.

Figure 15. Power-up Timing (DC-DC Regulator Wakeup by Setup Register, All Three Channels ON)

**V<sub>M</sub> Start-up/Power-Down and Glitch Condition**

1. Start up with V<sub>M</sub> glitch (not below V<sub>thVM-</sub>)

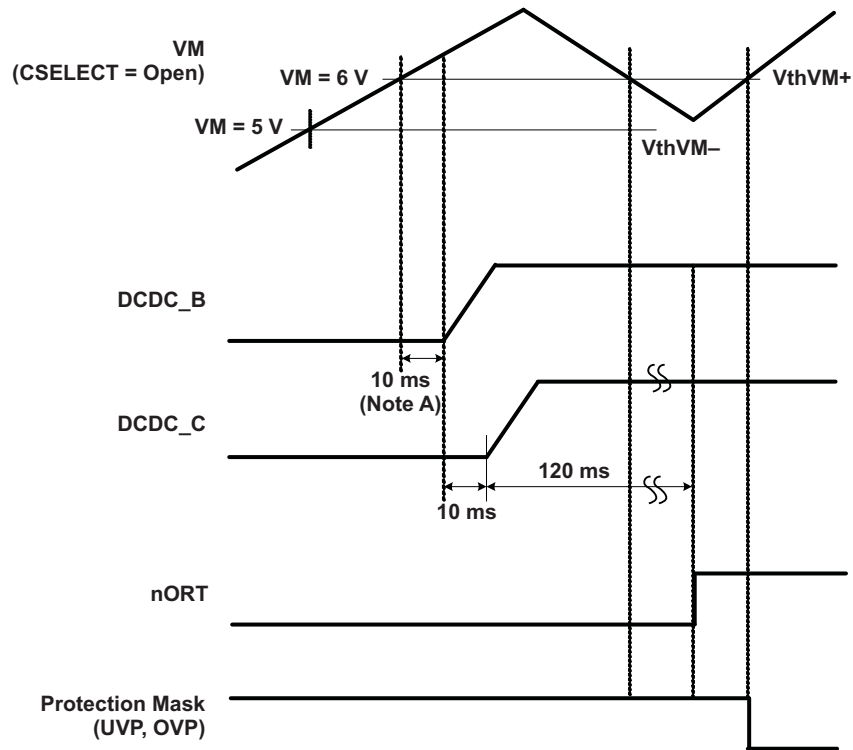

- A. LDO OCP is masked during protection mask time.

Figure 16.

2. Start up with  $V_M$  glitch (below  $V_{thVM-}$ )

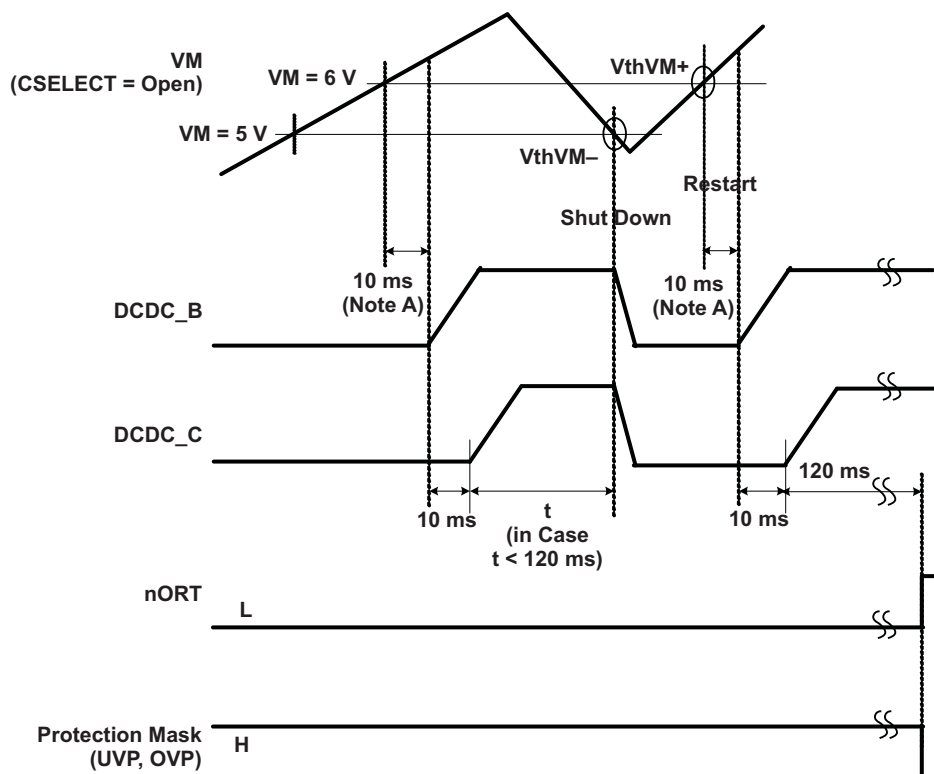

A. LDO OCP is masked during protection mask time.

Figure 17.

3. Power down (normal)

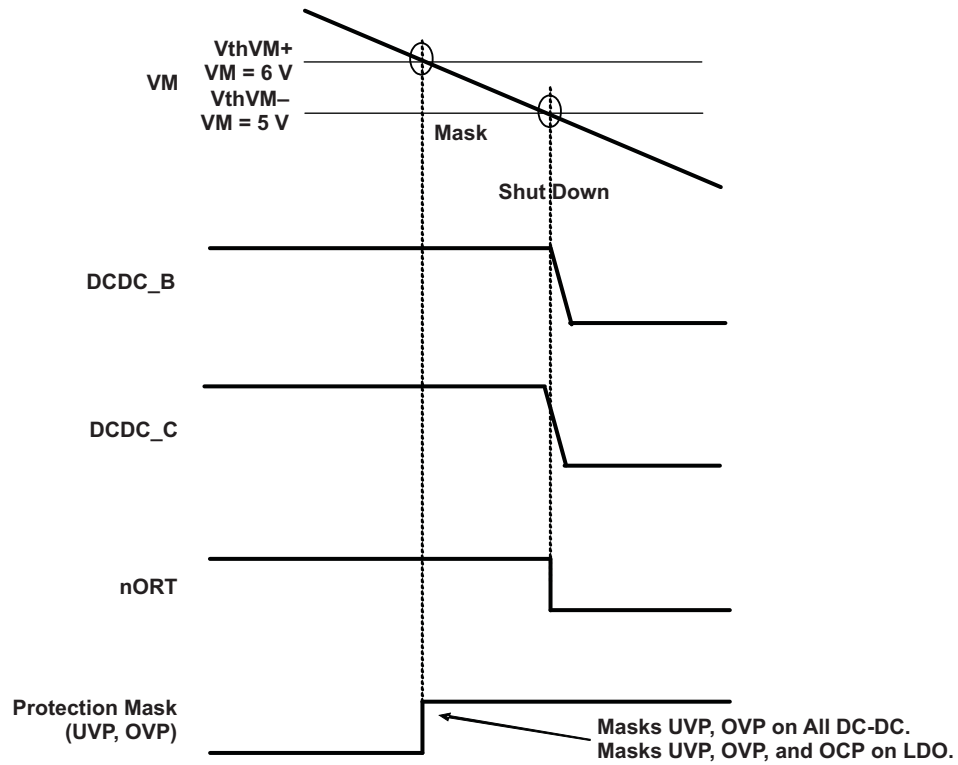

Figure 18.

4. Power down (glitch on  $V_M$ )

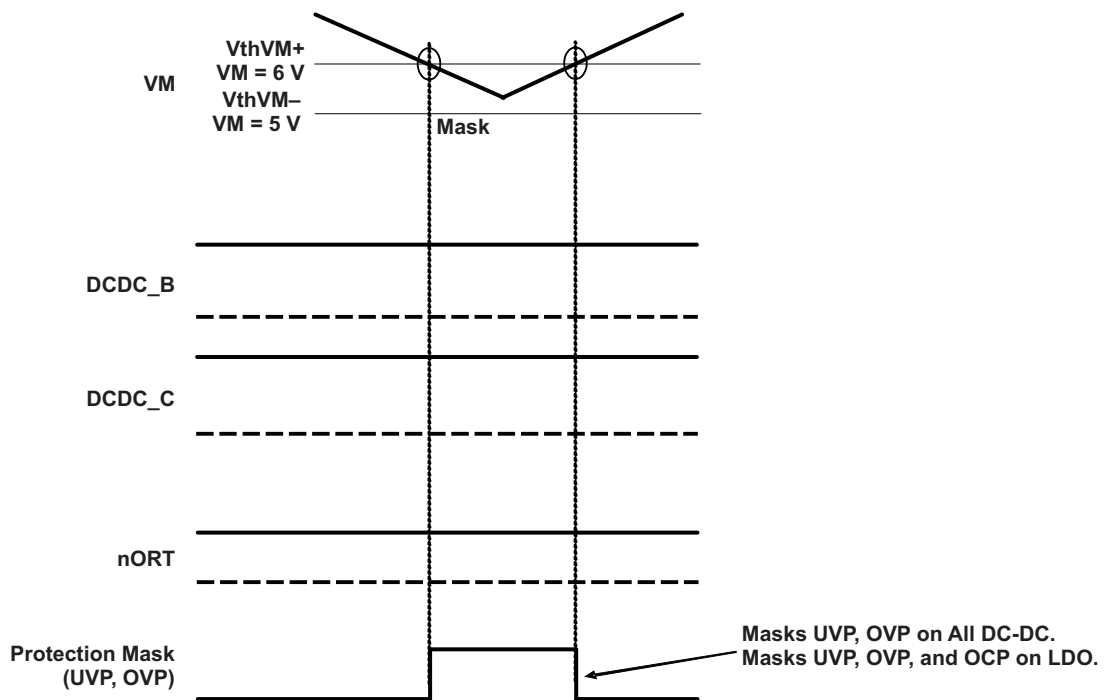
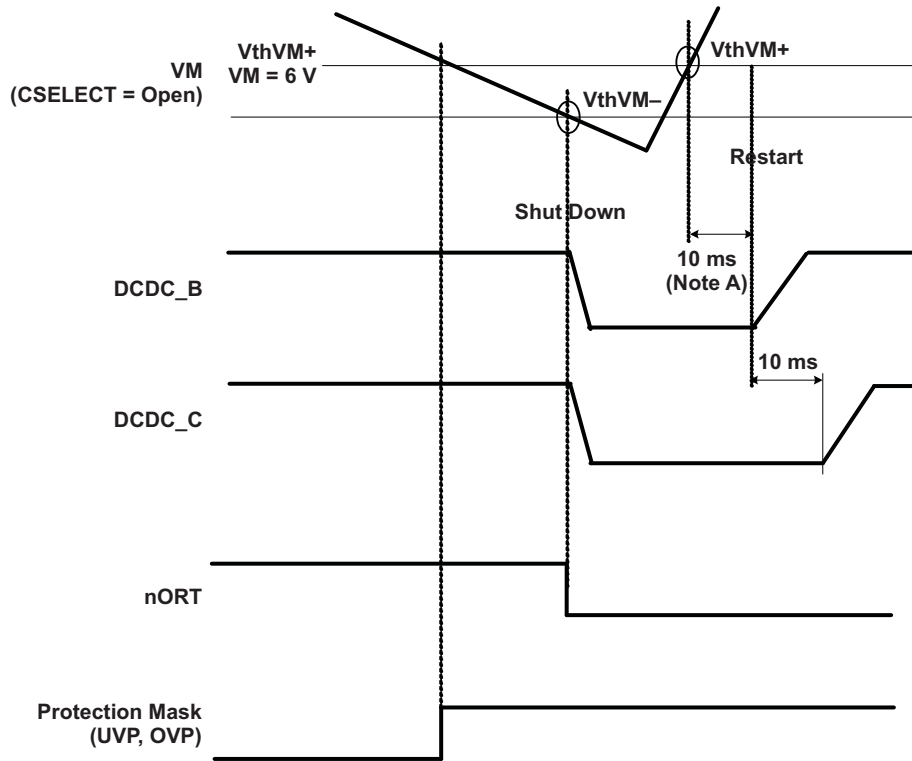

Figure 19.

5. Power down (glitch on  $V_M$  below  $V_{thVM-}$ )



A. LDO OCP is masked during protection mask time.

Figure 20.

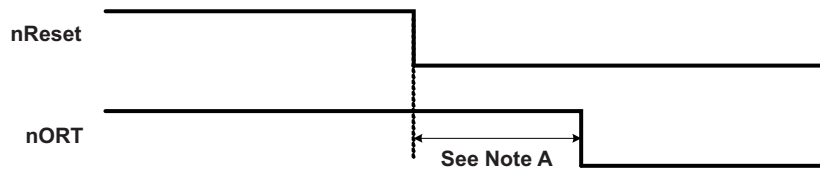

A.  $2.5 \mu s < (nReset \text{ Deglitch} + \text{Output Delay}) < 10 \mu s$

Figure 21. Shut Down by nReset

### Blanking Time Insertion Timing for DC Motor Driving

For the dc motor-driving H-bridge, tBlank is inserted at each phase reversal and following each chopping cycle (once in every eight OSCM clocks).

For a large n number (5 or 6), tBlank setup may decrease the Itrip detect window. Care must be taken when optimizing this in the system.

Case A: Phase duty = 25%

- A\*1 for setup bit = (1,0)
- A\*2 for setup bit = (0,1)

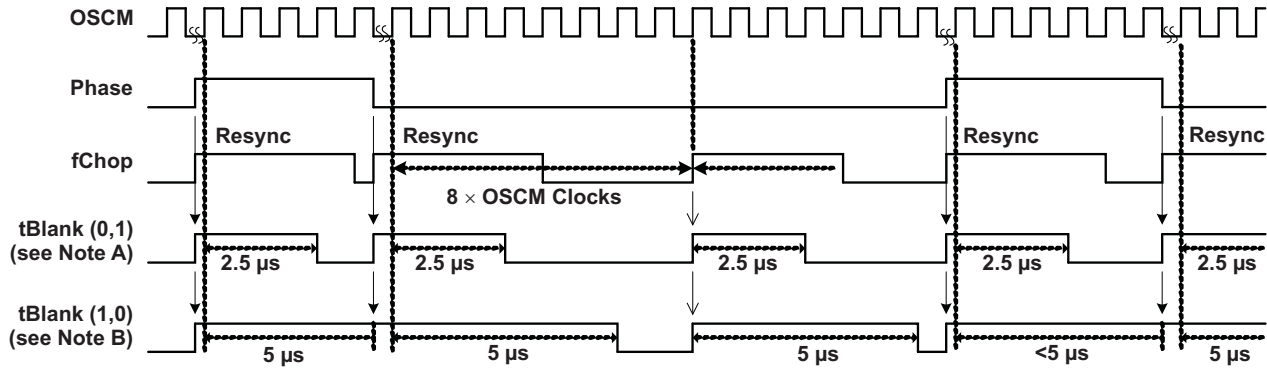

- A. Setup register bit <1:0> = (1,0), tBlank = 5 μs (or bits <3:2>/<5:4> for H-bridge B/C channel)
- B. Setup register bit <1:0> = (0,1), tBlank = 2.5 μs (or bits <3:2>/<5:4> for H-bridge B/C channel)

Case B: Phase duty = 40%

- B\*1 for setup bit = (1,0)
- B\*2 for setup bit = (0,1)

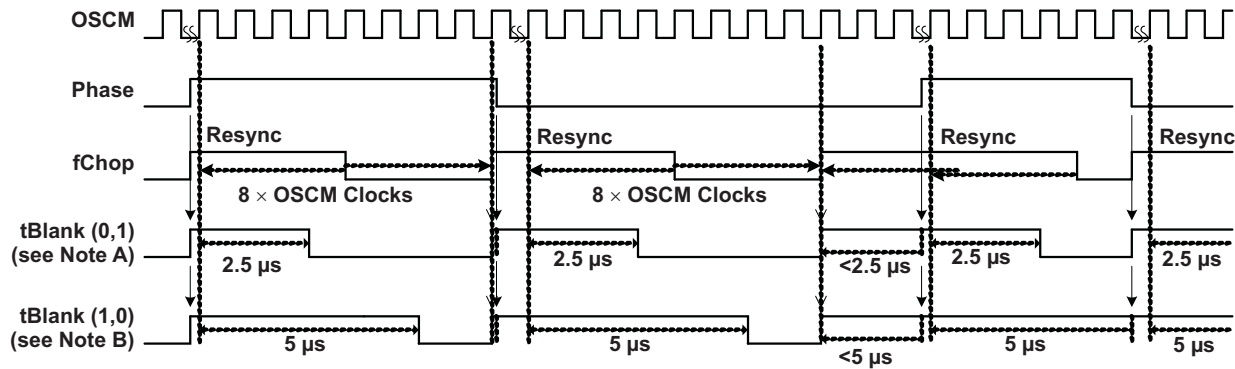

- A. Setup register bit <1:0> = (1,0), tBlank = 5 μs (or bits <3:2>/<5:4> for H-bridge B/C channel)
- B. Setup register bit <1:0> = (0,1), tBlank = 2.5 μs (or bits <3:2>/<5:4> for H-bridge B/C channel)



### Function Table in nORT, Power Down, $V_M$ Conditions

The following is valid only when the protection control bits (in Extended Setup register) are all 0.

**Table 11.**

DEVICE STATUS	CHARGE PUMP	OSCM	nORT	MODE SETTING
nSleep	Active	Active	Inactive	Available
nORT	Inactive	Active	Active	Depend on power down
$V_M < 6\text{ V}$ during power down	Active	Active	See timing chart	Depend on power down
$4.5\text{ V} < V_M$	Inactive	Inactive	Active	Unavailable

**Table 12. Shutdown Functions**

FAULT CONDITION	DCDC_A	DCDC_B	DCDC_C	MOTOR	nORT
DCDC_A UVP/OVP/OC	Shut down	Shut down	Shut down	Shut down	Asserted (low)
DCDC_B UVP/OVP/OC	Shut down	Shut down	Shut down	Shut down	Asserted (low)
DCDC_C UVP/OVP/OC	Shut down	Shut down	Shut down	Shut down	Asserted (low)
Motor OCP	See MISD Control Table	See MISD Control Table	See MISD Control Table	See MISD Control Table	See MISD Control Table
TSD	See TSD Control Table	See TSD Control Table	See TSD Control Table	See TSD Control Table	See TSD Control Table

- Table is valid when the Protection and Reset Mask bits in the Extended Setup register are all 0.
- If Reset Mask (selective shutdown) bits are set, shutdown and release description is in the note following the Extended Setup register definition.
- DC-DC regulators are released at  $V_M > V_{th_{VM+}}$  when  $V_M$  increasing. When  $V_M$  decreasing, regulators are shut down when  $V_M < V_{th_{VM-}}$ . When  $V_{th_{VM+}} > V_M > V_{th_{VM-}}$ , OVP and UVP are masked.
- Motor OCP shutdown release is specified in MISD Control Table.
- TSD shutdown release is specified in TSD Control Table.

**PACKAGING INFORMATION**

Orderable Device	Status <sup>(1)</sup>	Package Type	Package Drawing	Pins	Package Qty	Eco Plan <sup>(2)</sup>	Lead/Ball Finish	MSL Peak Temp <sup>(3)</sup>
DRV8808DCA	ACTIVE	HTSSOP	DCA	48	40	TBD	Call TI	Call TI
DRV8808DCAR	ACTIVE	HTSSOP	DCA	48	2000	Green (RoHS & no Sb/Br)	CU NIPDAU	Level-3-260C-168 HR

<sup>(1)</sup> The marketing status values are defined as follows:

**ACTIVE:** Product device recommended for new designs.

**LIFEBUY:** TI has announced that the device will be discontinued, and a lifetime-buy period is in effect.

**NRND:** Not recommended for new designs. Device is in production to support existing customers, but TI does not recommend using this part in a new design.

**PREVIEW:** Device has been announced but is not in production. Samples may or may not be available.

**OBSELETE:** TI has discontinued the production of the device.

<sup>(2)</sup> Eco Plan - The planned eco-friendly classification: Pb-Free (RoHS), Pb-Free (RoHS Exempt), or Green (RoHS & no Sb/Br) - please check <http://www.ti.com/productcontent> for the latest availability information and additional product content details.

**TBD:** The Pb-Free/Green conversion plan has not been defined.

**Pb-Free (RoHS):** TI's terms "Lead-Free" or "Pb-Free" mean semiconductor products that are compatible with the current RoHS requirements for all 6 substances, including the requirement that lead not exceed 0.1% by weight in homogeneous materials. Where designed to be soldered at high temperatures, TI Pb-Free products are suitable for use in specified lead-free processes.

**Pb-Free (RoHS Exempt):** This component has a RoHS exemption for either 1) lead-based flip-chip solder bumps used between the die and package, or 2) lead-based die adhesive used between the die and leadframe. The component is otherwise considered Pb-Free (RoHS compatible) as defined above.

**Green (RoHS & no Sb/Br):** TI defines "Green" to mean Pb-Free (RoHS compatible), and free of Bromine (Br) and Antimony (Sb) based flame retardants (Br or Sb do not exceed 0.1% by weight in homogeneous material)

<sup>(3)</sup> MSL, Peak Temp. -- The Moisture Sensitivity Level rating according to the JEDEC industry standard classifications, and peak solder temperature.

**Important Information and Disclaimer:**The information provided on this page represents TI's knowledge and belief as of the date that it is provided. TI bases its knowledge and belief on information provided by third parties, and makes no representation or warranty as to the accuracy of such information. Efforts are underway to better integrate information from third parties. TI has taken and continues to take reasonable steps to provide representative and accurate information but may not have conducted destructive testing or chemical analysis on incoming materials and chemicals. TI and TI suppliers consider certain information to be proprietary, and thus CAS numbers and other limited information may not be available for release.

In no event shall TI's liability arising out of such information exceed the total purchase price of the TI part(s) at issue in this document sold by TI to Customer on an annual basis.

DCA (R-PDSO-G48)

PowerPAD™ PLASTIC SMALL-OUTLINE

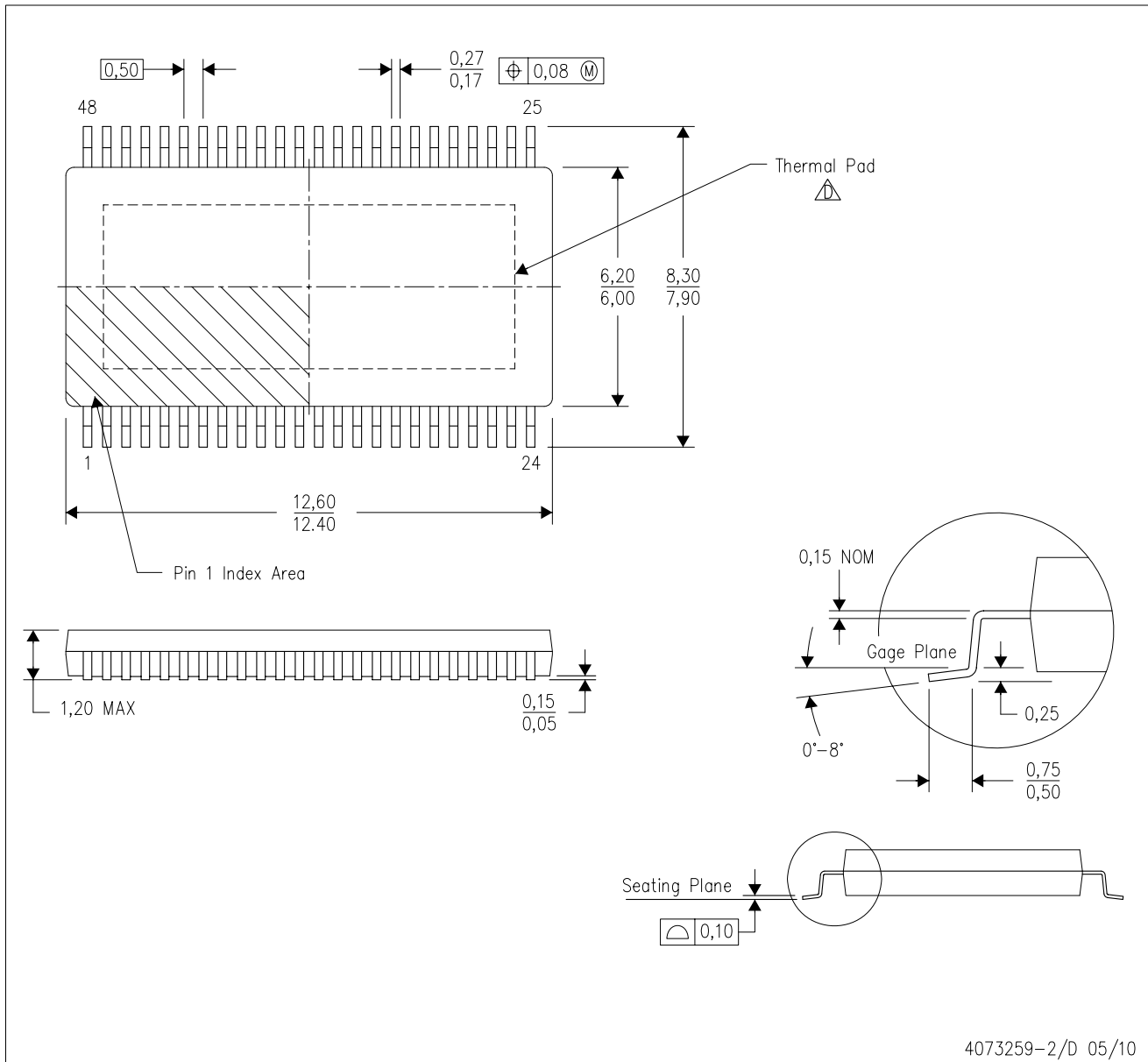

- NOTES:
- A. All linear dimensions are in millimeters. Dimensioning and tolerancing per ASME Y14.5M-1994.
  - B. This drawing is subject to change without notice.
  - C. Body dimensions do not include mold flash or protrusion not to exceed 0,15.
  - △ This package is designed to be soldered to a thermal pad on the board. Refer to Technical Brief, PowerPad Thermally Enhanced Package, Texas Instruments Literature No. SLMA002 for information regarding recommended board layout. This document is available at [www.ti.com](http://www.ti.com) <<http://www.ti.com>>.
  - E. Falls within JEDEC MO-153

PowerPAD is a trademark of Texas Instruments.

THERMAL INFORMATION

This PowerPAD™ package incorporates an exposed thermal pad that is designed to be attached to a printed circuit board (PCB). The thermal pad must be soldered directly to the PCB. After soldering, the PCB can be used as a heatsink. In addition, through the use of thermal vias, the thermal pad can be attached directly to the appropriate copper plane shown in the electrical schematic for the device, or alternatively, can be attached to a special heatsink structure designed into the PCB. This design optimizes the heat transfer from the integrated circuit (IC).

For additional information on the PowerPAD package and how to take advantage of its heat dissipating abilities, refer to Technical Brief, PowerPAD Thermally Enhanced Package, Texas Instruments Literature No. SLMA002 and Application Brief, PowerPAD Made Easy, Texas Instruments Literature No. SLMA004. Both documents are available at [www.ti.com](http://www.ti.com).

The exposed thermal pad dimensions for this package are shown in the following illustration.

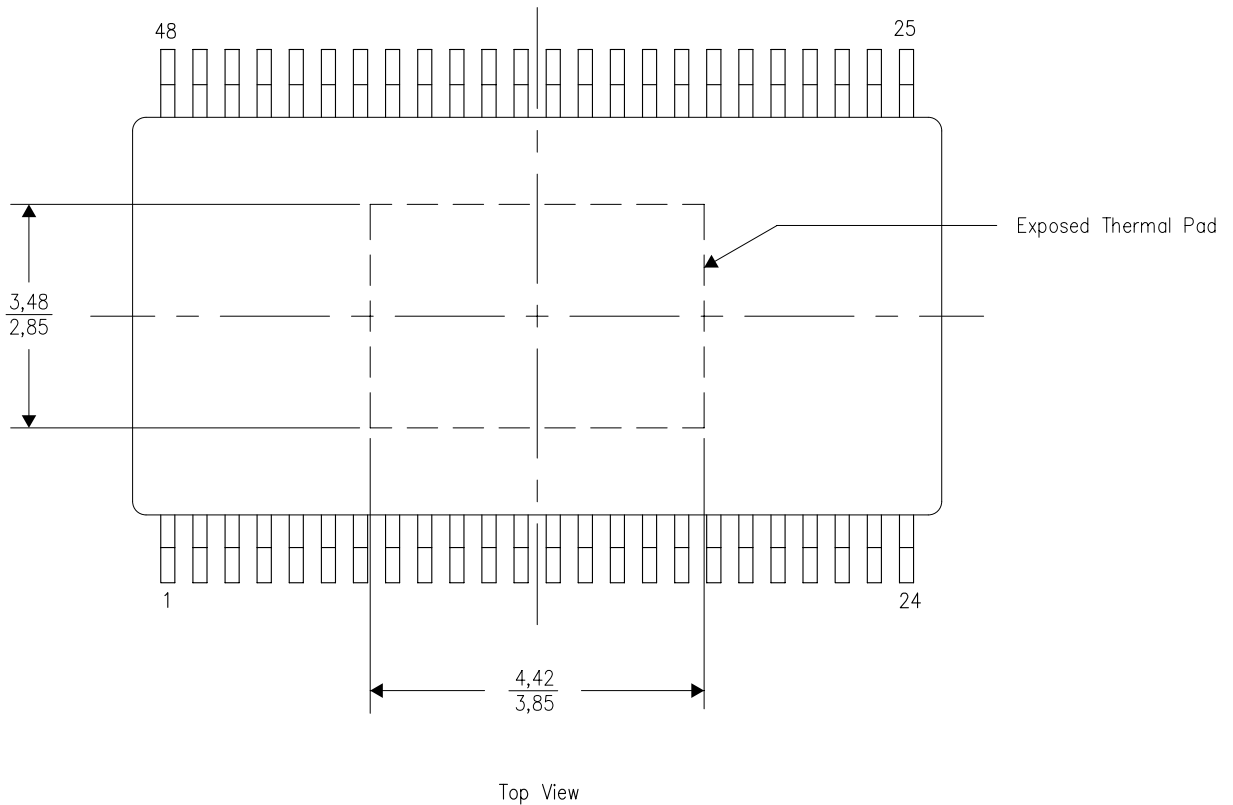

NOTE: All linear dimensions are in millimeters

Exposed Thermal Pad Dimensions

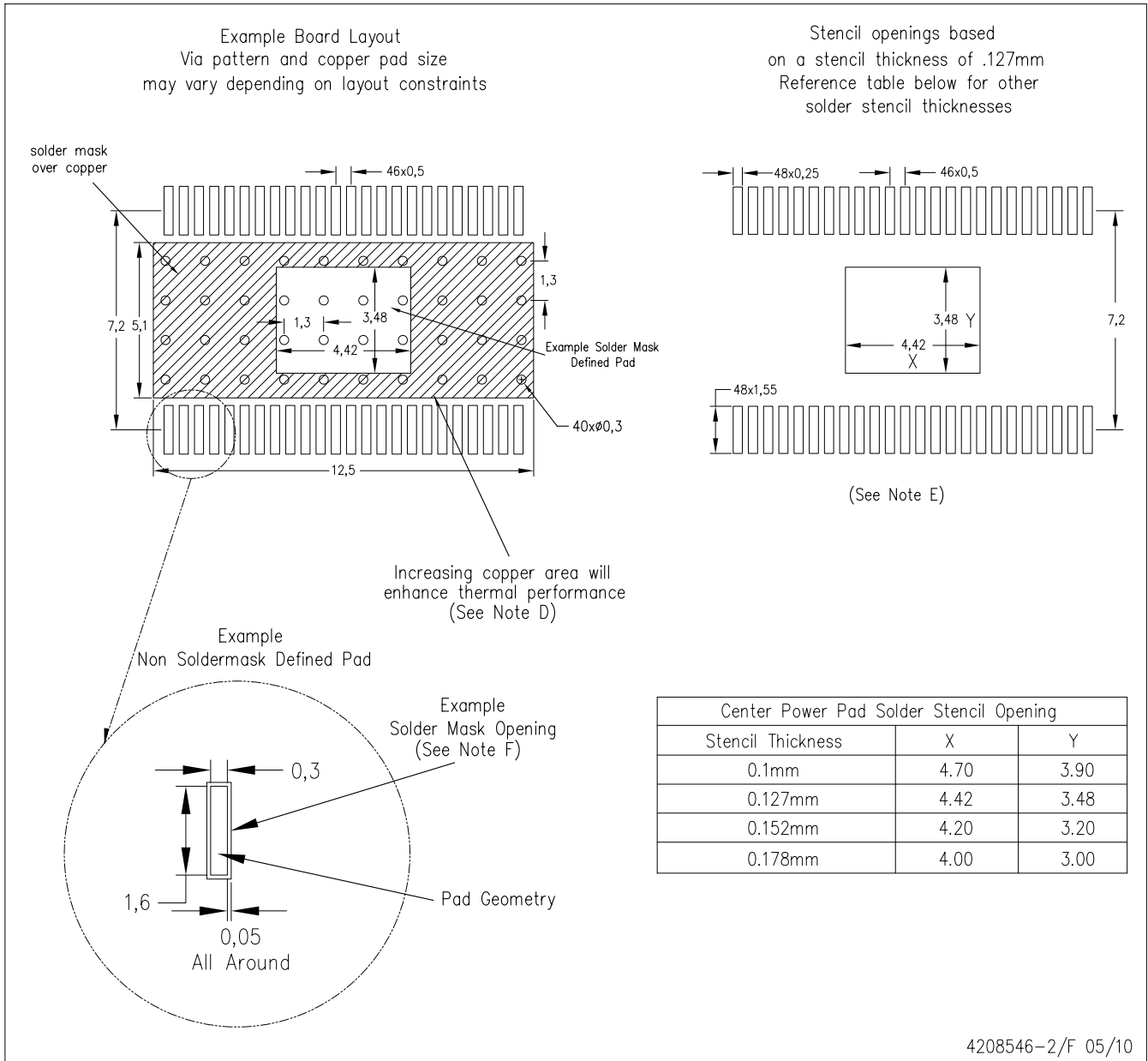

- NOTES:
- A. All linear dimensions are in millimeters.
  - B. This drawing is subject to change without notice.
  - C. Customers should place a note on the circuit board fabrication drawing not to alter the center solder mask defined pad.
  - D. This package is designed to be soldered to a thermal pad on the board. Refer to Technical Brief, PowerPAD Thermally Enhanced Package, Texas Instruments Literature No. SLMA002, SLMA004, and also the Product Data Sheets for specific thermal information, via requirements, and recommended board layout. These documents are available at [www.ti.com](http://www.ti.com) <<http://www.ti.com>>. Publication IPC-7351 is recommended for alternate designs.
  - E. Laser cutting apertures with trapezoidal walls and also rounding corners will offer better paste release. Customers should contact their board assembly site for stencil design recommendations. Example stencil design based on a 50% volumetric metal load solder paste. Refer to IPC-7525 for other stencil recommendations.
  - F. Customers should contact their board fabrication site for solder mask tolerances between and around signal pads.

## IMPORTANT NOTICE

Texas Instruments Incorporated and its subsidiaries (TI) reserve the right to make corrections, modifications, enhancements, improvements, and other changes to its products and services at any time and to discontinue any product or service without notice. Customers should obtain the latest relevant information before placing orders and should verify that such information is current and complete. All products are sold subject to TI's terms and conditions of sale supplied at the time of order acknowledgment.

TI warrants performance of its hardware products to the specifications applicable at the time of sale in accordance with TI's standard warranty. Testing and other quality control techniques are used to the extent TI deems necessary to support this warranty. Except where mandated by government requirements, testing of all parameters of each product is not necessarily performed.

TI assumes no liability for applications assistance or customer product design. Customers are responsible for their products and applications using TI components. To minimize the risks associated with customer products and applications, customers should provide adequate design and operating safeguards.

TI does not warrant or represent that any license, either express or implied, is granted under any TI patent right, copyright, mask work right, or other TI intellectual property right relating to any combination, machine, or process in which TI products or services are used. Information published by TI regarding third-party products or services does not constitute a license from TI to use such products or services or a warranty or endorsement thereof. Use of such information may require a license from a third party under the patents or other intellectual property of the third party, or a license from TI under the patents or other intellectual property of TI.

Reproduction of TI information in TI data books or data sheets is permissible only if reproduction is without alteration and is accompanied by all associated warranties, conditions, limitations, and notices. Reproduction of this information with alteration is an unfair and deceptive business practice. TI is not responsible or liable for such altered documentation. Information of third parties may be subject to additional restrictions.

Resale of TI products or services with statements different from or beyond the parameters stated by TI for that product or service voids all express and any implied warranties for the associated TI product or service and is an unfair and deceptive business practice. TI is not responsible or liable for any such statements.

TI products are not authorized for use in safety-critical applications (such as life support) where a failure of the TI product would reasonably be expected to cause severe personal injury or death, unless officers of the parties have executed an agreement specifically governing such use. Buyers represent that they have all necessary expertise in the safety and regulatory ramifications of their applications, and acknowledge and agree that they are solely responsible for all legal, regulatory and safety-related requirements concerning their products and any use of TI products in such safety-critical applications, notwithstanding any applications-related information or support that may be provided by TI. Further, Buyers must fully indemnify TI and its representatives against any damages arising out of the use of TI products in such safety-critical applications.

TI products are neither designed nor intended for use in military/aerospace applications or environments unless the TI products are specifically designated by TI as military-grade or "enhanced plastic." Only products designated by TI as military-grade meet military specifications. Buyers acknowledge and agree that any such use of TI products which TI has not designated as military-grade is solely at the Buyer's risk, and that they are solely responsible for compliance with all legal and regulatory requirements in connection with such use.

TI products are neither designed nor intended for use in automotive applications or environments unless the specific TI products are designated by TI as compliant with ISO/TS 16949 requirements. Buyers acknowledge and agree that, if they use any non-designated products in automotive applications, TI will not be responsible for any failure to meet such requirements.

Following are URLs where you can obtain information on other Texas Instruments products and application solutions:

<b>Products</b>		<b>Applications</b>	
Amplifiers	<a href="http://amplifier.ti.com">amplifier.ti.com</a>	Audio	<a href="http://www.ti.com/audio">www.ti.com/audio</a>
Data Converters	<a href="http://dataconverter.ti.com">dataconverter.ti.com</a>	Automotive	<a href="http://www.ti.com/automotive">www.ti.com/automotive</a>
DLP® Products	<a href="http://www.dlp.com">www.dlp.com</a>	Communications and Telecom	<a href="http://www.ti.com/communications">www.ti.com/communications</a>
DSP	<a href="http://dsp.ti.com">dsp.ti.com</a>	Computers and Peripherals	<a href="http://www.ti.com/computers">www.ti.com/computers</a>
Clocks and Timers	<a href="http://www.ti.com/clocks">www.ti.com/clocks</a>	Consumer Electronics	<a href="http://www.ti.com/consumer-apps">www.ti.com/consumer-apps</a>
Interface	<a href="http://interface.ti.com">interface.ti.com</a>	Energy	<a href="http://www.ti.com/energy">www.ti.com/energy</a>
Logic	<a href="http://logic.ti.com">logic.ti.com</a>	Industrial	<a href="http://www.ti.com/industrial">www.ti.com/industrial</a>
Power Mgmt	<a href="http://power.ti.com">power.ti.com</a>	Medical	<a href="http://www.ti.com/medical">www.ti.com/medical</a>
Microcontrollers	<a href="http://microcontroller.ti.com">microcontroller.ti.com</a>	Security	<a href="http://www.ti.com/security">www.ti.com/security</a>
RFID	<a href="http://www.ti-rfid.com">www.ti-rfid.com</a>	Space, Avionics & Defense	<a href="http://www.ti.com/space-avionics-defense">www.ti.com/space-avionics-defense</a>
RF/IF and ZigBee® Solutions	<a href="http://www.ti.com/lprf">www.ti.com/lprf</a>	Video and Imaging	<a href="http://www.ti.com/video">www.ti.com/video</a>
		Wireless	<a href="http://www.ti.com/wireless-apps">www.ti.com/wireless-apps</a>