

查询"5962-88575013A"供应商

REVISIONS

LTR	DESCRIPTION	DATE (YR-MO-DA)	APPROVED

REV																								
SHEET																								
REV																								
SHEET																								
REV STATUS OF SHEETS	REV																							
	SHEET	1	2	3	4	5	6	7	8	9	10	11	12	13	14									

PMIC N/A	PREPARED BY <i>Marcia B Kelleher</i>	DEFENSE ELECTRONICS SUPPLY CENTER DAYTON, OHIO 45444		
STANDARDIZED MILITARY DRAWING THIS DRAWING IS AVAILABLE FOR USE BY ALL DEPARTMENTS AND AGENCIES OF THE DEPARTMENT OF DEFENSE	CHECKED BY <i>Wm Johnson</i>			
	APPROVED BY <i>[Signature]</i>	SIZE A	CAGE CODE 67268	5962-88575
	DRAWING APPROVAL DATE 27 SEPTEMBER 1989	REVISION LEVEL		
AMSC N/A	SHEET 1 OF 14			

DESC FORM 193
SEP 87

• U.S. GOVERNMENT PRINTING OFFICE: 1987 - 748-129/60911

DISTRIBUTION STATEMENT A. Approved for public release; distribution is unlimited.

5962-E858

1.1 Scope. This drawing describes device requirements for class B microcircuits in accordance with 1.2.1 of MIL-STD-883, "Provisions for the use of MIL-STD-883 in conjunction with compliant non-JAN devices".

1.2 Part number. The complete part number shall be as shown in the following example:

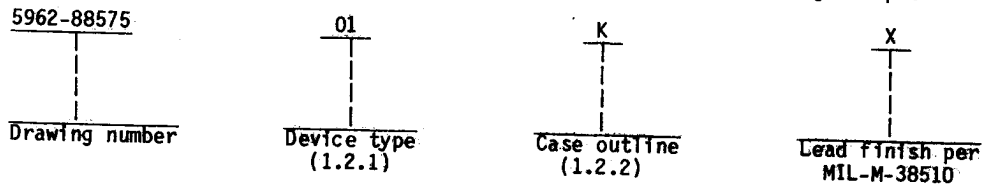

1.2.1 Device type. The device type shall identify the circuit function as follows:

<u>Device type</u>	<u>Generic number</u>	<u>Circuit function</u>
01	54FCT841A	10-bit noninverting bus interface latch with three-state output, TTL compatible
02	54FCT841B	10-bit noninverting bus interface latch, with three-state output, TTL compatible

1.2.2 Case outlines. The case outlines shall be as designated in appendix C of MIL-M-38510, and as follows:

<u>Outline letter</u>	<u>Case outline</u>
K	F-6 (24 lead, .640" x .420" x .090"), flat package
L	D-9 (24 lead, 1.280" x .310" x .200"), dual-in-line package
3	C-4 (28-terminal, .460" x .460" x .100"), square chip carrier package

1.3 Absolute maximum ratings.

Supply voltage range	-0.5 V dc to +7.0 V dc
Input voltage range	-0.5 V dc to $V_{CC} + 0.5$ V dc
Output voltage range	-0.5 V dc to $V_{CC} + 0.5$ V dc
DC input diode current (I_{IK})	-20 mA
DC output diode current (I_{OK})	-50 mA
DC output current	±100 mA
Maximum power dissipation (P_D) ^{2/}	500 mW
Thermal resistance, junction to case (θ_{JC})	See MIL-M-38510, appendix C
Storage temperature range	-65°C to +150°C
Junction temperature (T_J)	+175°C
Lead temperature (soldering, 10 seconds)	+300°C

1.4 Recommended operating conditions.

Supply voltage (V_{CC})	+4.5 V dc to +5.5 V dc
Maximum low level input voltage (V_{IL})	0.8 V dc
Minimum high level input voltage (V_{IH})	2.0 V dc
Case operating temperature range (T_C)	-55°C to +125°C

1/ All voltages referenced to GND.

2/ Must withstand the added P_D due to short circuit test, e.g., I_{OS} .

STANDARDIZED MILITARY DRAWING DEFENSE ELECTRONICS SUPPLY CENTER DAYTON, OHIO 45444	SIZE A	5962-88575
	REVISION LEVEL	SHEET 2

查询"6962-88575-13A"供应商

Device type 01	-----	2.5 ns
Device type 02	-----	2.5 ns
Minimum hold time, Dn to LE, (t _H):		
Device type 01	-----	3.0 ns
Device type 02	-----	2.5 ns
Minimum pulse width, LE, (t _W):		
Device type 01	-----	6.0 ns
Device type 02	-----	4.0 ns

2. APPLICABLE DOCUMENTS

2.1 Government specification, standard, and bulletin. Unless otherwise specified, the following specification, standard, and bulletin of the issue listed in that issue of the Department of Defense Index of Specifications and Standards specified in the solicitation, form a part of this drawing to the extent specified herein.

SPECIFICATION

MILITARY

MIL-M-38510 - Microcircuits, General Specification for.

STANDARD

MILITARY

MIL-STD-883 - Test Methods and Procedures for Microelectronics.

BULLETIN

MILITARY

MIL-BUL-103 - List of Standardized Military Drawings (SMD's).

(Copies of the specification, standard, and bulletin required by manufacturers in connection with specific acquisition functions should be obtained from the contracting activity or as directed by the contracting activity.)

2.2 Order of precedence. In the event of a conflict between the text of this drawing and the references cited herein, the text of this drawing shall take precedence.

3. REQUIREMENTS

3.1 Item requirements. The individual item requirements shall be in accordance with 1.2.1 of MIL-STD-883, "Provisions for the use of MIL-STD-883 in conjunction with compliant non-JAN devices" and as specified herein.

3.2 Design, construction, and physical dimensions. The design, construction, and physical dimensions shall be as specified in MIL-M-38510 and herein.

3.2.1 Terminal connections. The terminal connections shall be as specified on figure 1.

3.2.2 Truth table. The truth table shall be as specified on figure 2.

3.2.3 Logic diagram. The logic diagram shall be as specified on figure 3.

3.2.4 Case outlines. The case outlines shall be in accordance with 1.2.2 herein.

STANDARDIZED MILITARY DRAWING DEFENSE ELECTRONICS SUPPLY CENTER DAYTON, OHIO 45444	SIZE A		5962-88575
		REVISION LEVEL	SHEET 3

DESC FORM 193A
SEP 87

★ U. S. GOVERNMENT PRINTING OFFICE: 1968-549-904

TABLE I. Electrical performance characteristics.

Test	Symbol	Conditions: -55°C < T _C < +125°C V _{CC} = 5.0 V dc ±10% unless otherwise specified.	Device type	Group A subgroups	Limits		Unit
					Min	Max	
High level output voltage	V _{OH}	V _{CC} = 4.5 V, V _{IL} = 0.8 V, V _{IH} = 2.0 V	I _{OH} = -300 μA	A11	1, 2, 3	4.3	V
			I _{OH} = -15 mA	A11	1, 2, 3	2.4	
Low level output voltage	V _{OL}	V _{CC} = 4.5 V, V _{IL} = 0.8 V, V _{IH} = 2.0 V	I _{OL} = 300 μA	A11	1, 2, 3		0.2 V
			I _{OL} = 32 mA	A11	1, 2, 3		0.5
Input clamp voltage	V _{IK}	V _{CC} = 4.5 V, I _{IN} = -18 mA	A11	1, 2, 3		-1.2	V
High level input current	I _{IH}	V _{CC} = 5.5 V, V _{IN} = 5.5 V	A11	1, 2, 3		5.0	μA
Low level input current	I _{IL}	V _{CC} = 5.5 V, V _{IN} = GND	A11	1, 2, 3		-5.0	μA
High impedance output current	I _{OZH}	V _{CC} = 5.5 V, V _{IN} = 5.5 V	A11	1, 2, 3		10	μA
	I _{OZL}	V _{CC} = 5.5 V, V _{IN} = GND	A11	1, 2, 3		-10	μA
Short circuit output current	I _{OS}	V _{CC} = 5.5 V 1/ V _O = GND	A11	1, 2, 3	-75		mA
Quiescent power supply current (CMOS inputs)	I _{CCQ}	V _{IN} ≤ 0.2 V or V _{IN} > 5.3 V, V _{CC} = 5.5 V, f _I = 0 MHz	A11	1, 2, 3		1.5	mA
Quiescent power supply current (TTL inputs)	ΔI _{CC}	V _{CC} = 5.5 V, V _{IN} = 3.4 V 2/	A11	1, 2, 3		2.0	mA
Dynamic power supply current	I _{CCD}	V _{CC} = 5.5 V, OE = GND, One bit toggling, 50% duty cycle, V _{IN} ≥ 5.3 V or V _{IN} < 0.2 V Outputs open, LE = V _{CC}	A11	3/		0.25	mA/MHz

See footnotes at end of table.

STANDARDIZED MILITARY DRAWING DEFENSE ELECTRONICS SUPPLY CENTER DAYTON, OHIO 45444	SIZE A	5962-88575	
		REVISION LEVEL	SHEET 4

DESC FORM 193A
SEP 87

查询"5962-88575018A"供应 Electrical performance characteristics - Continued.

Test	Symbol	Conditions -55°C ≤ T _C < +125°C V _{CC} = 5.0 V dc ±10% unless otherwise specified	Device type	Group A subgroups	Limits		Unit	
					Min	Max		
Total power supply current	I _{CC}	V _{CC} = 5.5 V, outputs open, f _I = 10 MHz, 50% duty cycle, One bit toggling, OE = GND, LE = V _{CC} 4/	V _{IN} ≥ 5.3 V or V _{IN} ≤ 0.2 V	A11	1, 2, 3		4.0	mA
			V _{IN} = 3.4 V or V _{IN} = GND	A11	1, 2, 3		5.0	mA
Input capacitance	C _{IN}	See 4.3.1c	A11	4			10	pF
Output capacitance	C _{OUT}	See 4.3.1c	A11	4			12	pF
Functional tests		See 4.3.1d	A11	7, 8				
Propagation delay time Dn to Yn (LE = high)	t _{PLH1} , t _{PHL1}	C _L = 50 pF, R _L = 500Ω, See figure 4 5/	01	9, 10, 11	1.5	10.0	ns	
			02		1.5	7.5		
Propagation delay time LE to Yn	t _{PLH2} , t _{PHL2}		01	9, 10, 11	1.5	13.0	ns	
			02		1.5	10.5		
Output enable time, OE to Yn	t _{pZH} , t _{pZL}		01	9, 10, 11	1.5	13.0	ns	
			02		1.5	8.5		
Output disable time, OE to Yn	t _{PHZ} , t _{PLZ}		01	9, 10, 11	1.5	10.0	ns	
			02		1.5	7.5		

- 1/ Not more than one output should be shorted at one time, and the duration of the short circuit condition should not exceed 1 second.
- 2/ TTL driven input (V_{IN} = 3.4 V); all other inputs at V_{CC} or GND.
- 3/ This parameter is not directly testable, but is derived for use in total power supply calculations.
- 4/ I_{CC} = I_{CCQ} + (ΔI_{CC} × D_H × N_T) + (I_{CCD} × f_I × N_I) where:
 D_H = Duty cycle for TTL inputs high
 N_T = Number of TTL inputs at D_H
 f_I = Input frequency in MHz
 N_I = Number of inputs at f_I
- 5/ The minimum limits are guaranteed, if not tested, to the limits specified in table I.

STANDARDIZED MILITARY DRAWING DEFENSE ELECTRONICS SUPPLY CENTER DAYTON, OHIO 45444	SIZE A		5962-88575
		REVISION LEVEL	SHEET 5

DESC FORM 193A
SEP 87

* U. S. GOVERNMENT PRINTING OFFICE: 1988-548-904

Device types 01 and 02		
Case outline	E, F	2
Terminal number	Terminal symbol	
1	OE	NC
2	D0	OE
3	D1	D0
4	D2	D1
5	D3	D2
6	D4	D3
7	D5	D4
8	D6	NC
9	D7	D5
10	D8	D6
11	D9	D7
12	GND	D8
13	LE	D9
14	Y9	GND
15	Y8	NC
16	Y7	LE
17	Y6	Y9
18	Y5	Y8
19	Y4	Y7
20	Y3	Y6
21	Y2	Y5
22	Y1	NC
23	Y0	Y4
24	VCC	Y3
25	---	Y2
26	---	Y1
27	---	Y0
28	---	VCC

FIGURE 1. Terminal connections.

STANDARDIZED MILITARY DRAWING DEFENSE ELECTRONICS SUPPLY CENTER DAYTON, OHIO 45444	SIZE A		5962-88575
		REVISION LEVEL	SHEET 6

DESC FORM 193A
SEP 87

Device types 01 and 02				
Inputs			Outputs	Function
OE	LE	Dn	Yn	
L	H	H	H	Transparent
L	H	L	L	Transparent
L	L	X	NC	Latched
H	X	X	Z	High Z
H	H	L	Z	High Z
H	H	H	Z	High Z
H	L	X	Z	Latched (High Z)

H = High voltage level
 L = Low voltage level
 X = Irrelevant
 Z = High impedance
 NC = No change

FIGURE 2. Truth table.

STANDARDIZED MILITARY DRAWING DEFENSE ELECTRONICS SUPPLY CENTER DAYTON, OHIO 45444	SIZE A		5962-88575
		REVISION LEVEL	SHEET 7

DESC FORM 193A
 SEP 87

Device type 01

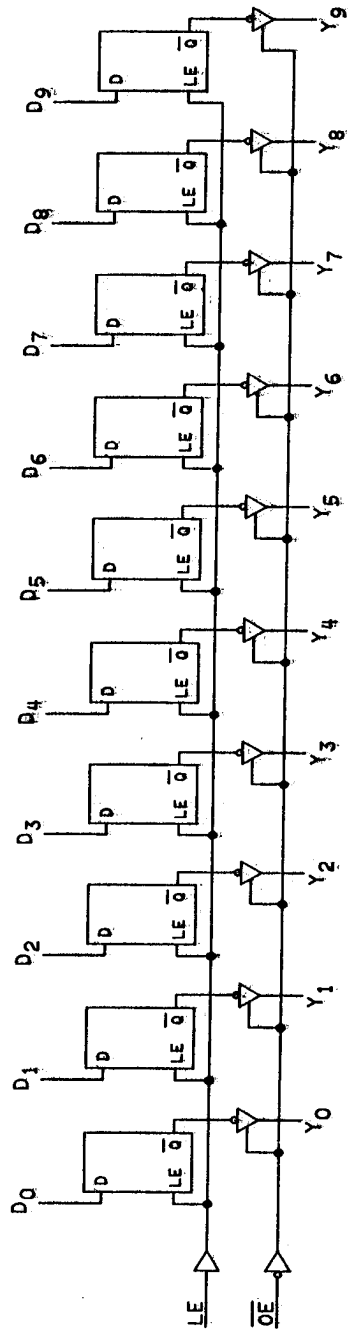
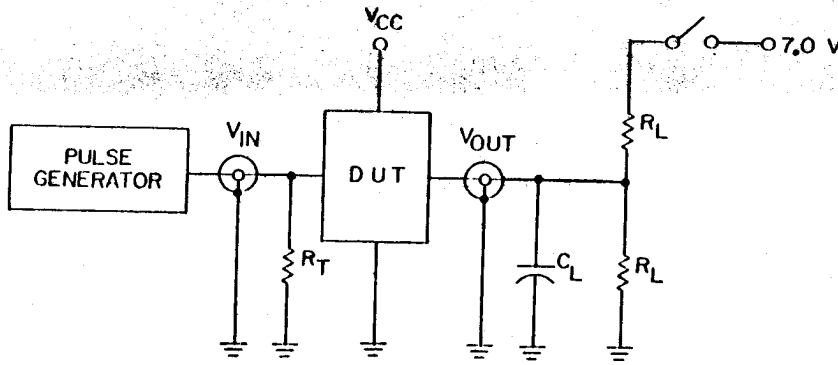

FIGURE 3. Logic diagram.

STANDARDIZED MILITARY DRAWING DEFENSE ELECTRONICS SUPPLY CENTER DAYTON, OHIO 45444	SIZE A	5962-88575	
		REVISION LEVEL	SHEET 8

DESC FORM 193A
SEP 87



Switch position

Test	Switch
t_{PLZ}	Closed
t_{pZL}	Closed
All other	Open

Definitions:

R_L = Load resistance.

See ac characteristics for value.

C_L = Load capacitance includes jig and probe capacitance.

See ac characteristics for value.

R_T = Termination resistance and should be equal to Z_{OUT} of the pulse generators.

V_{IN} = 0 V to 3.0 V.

Input: $t_r = t_f = 2.5$ ns (10 percent to 90 percent), unless otherwise specified.

FIGURE 4. Switching waveforms and test circuits.

STANDARDIZED MILITARY DRAWING DEFENSE ELECTRONICS SUPPLY CENTER DAYTON, OHIO 45444	SIZE A		5962-88575
		REVISION LEVEL	SHEET 9

DESC FORM 193A
SEP 87

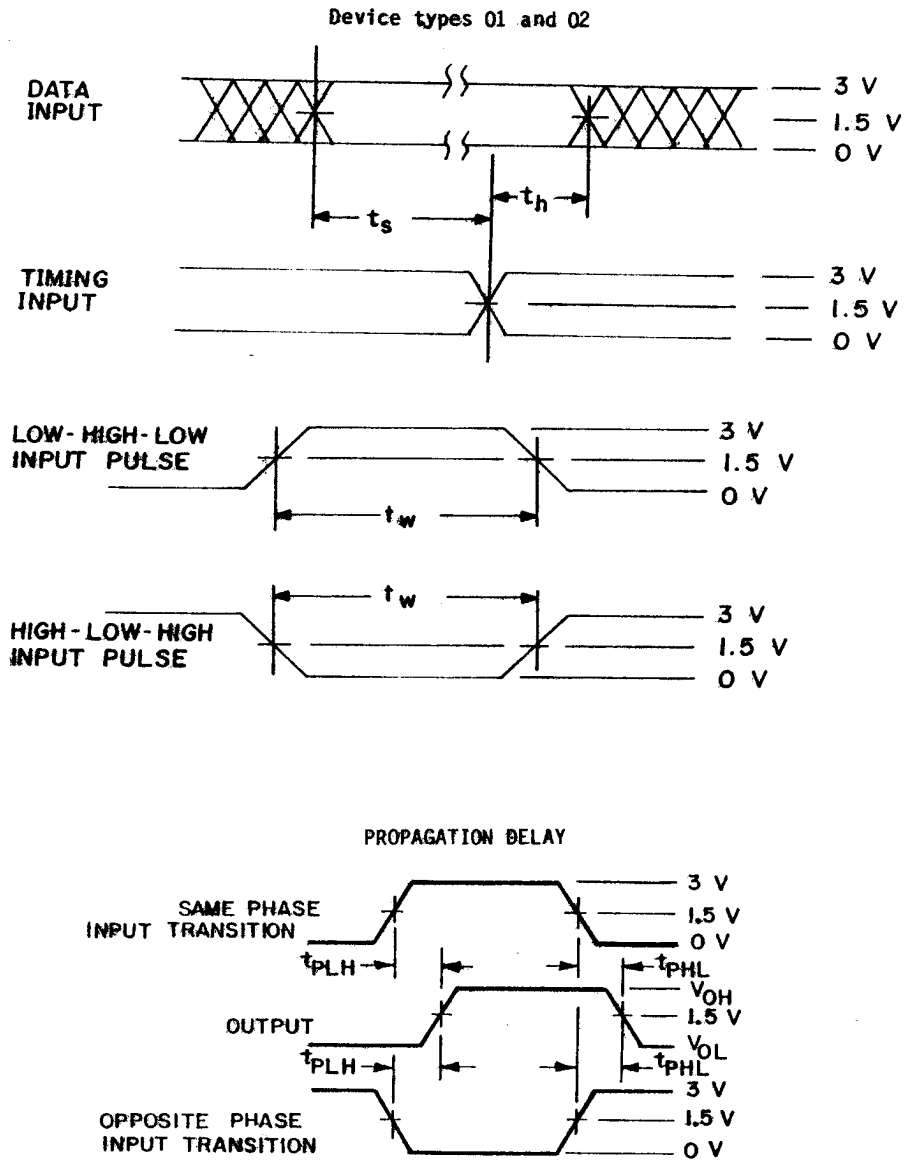

FIGURE 4. Switching time waveforms and test circuit - Continued.

STANDARDIZED MILITARY DRAWING DEFENSE ELECTRONICS SUPPLY CENTER DAYTON, OHIO 45444	SIZE A	5962-88575
	REVISION LEVEL	SHEET 10

DESC FORM 193A
SEP 87

* U. S. GOVERNMENT PRINTING OFFICE: 1968-549-004

Device types 01 and 02
Enable and disable times

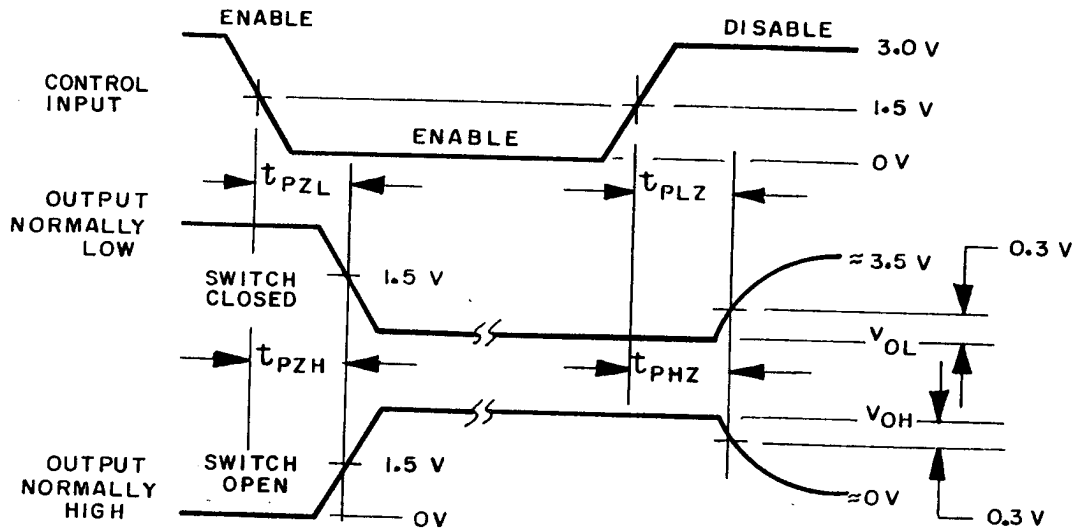

Notes:

1. Diagram shown for input control enable - low and input control disable - high.
2. Pulse generator for all pulses: $t_f \leq 2.5 \text{ ns}$; $t_r \leq 2.5 \text{ ns}$.

FIGURE 4. Switching time waveforms and test circuit - Continued.

STANDARDIZED MILITARY DRAWING DEFENSE ELECTRONICS SUPPLY CENTER DAYTON, OHIO 45444	SIZE A	5962-88575	
		REVISION LEVEL	SHEET 11

DESC FORM 193A
SEP 87

* U. S. GOVERNMENT PRINTING OFFICE: 1988-549-904

3.3 Electrical performance characteristics. Unless otherwise specified herein, the electrical performance characteristics are as specified in table I and apply over the full case operating temperature range.

3.4 Electrical test requirements. The electrical test requirements shall be the subgroups specified in table II. The electrical tests for each subgroup are described in table I.

3.5 Marking. Marking shall be in accordance with MIL-STD-883 (see 3.1 herein). The part shall be marked with the part number listed in 1.2 herein. In addition, the manufacturer's part number may also be marked as listed in MIL-BUL-103 (see 6.6 herein).

3.6 Certificate of compliance. A certificate of compliance shall be required from a manufacturer in order to be listed as an approved source of supply in MIL-BUL-103 (see 6.6 herein). The certificate of compliance submitted to DESC-ECS prior to listing as an approved source of supply shall affirm that the manufacturer's product meets the requirements of MIL-STD-883 (see 3.1 herein) and the requirements herein.

3.7 Certificate of conformance. A certificate of conformance as required in MIL-STD-883 (see 3.1 herein) shall be provided with each lot of microcircuits delivered to this drawing.

3.8 Notification of change. Notification of change to DESC-ECS shall be required in accordance with MIL-STD-883 (see 3.1 herein).

3.9 Verification and review. DESC, DESC's agent, and the acquiring activity retain the option to review the manufacturer's facility and applicable required documentation. Offshore documentation shall be made available onshore at the option of the reviewer.

4. QUALITY ASSURANCE PROVISIONS

4.1 Sampling and inspection. Sampling and inspection procedures shall be in accordance with section 4 of MIL-M-38510 to the extent specified in MIL-STD-883 (see 3.1 herein).

4.2 Screening. Screening shall be in accordance with method 5004 of MIL-STD-883, and shall be conducted on all devices prior to quality conformance inspection. The following additional criteria shall apply:

- a. Burn-in test, method 1015 of MIL-STD-883.
 - (1) Test condition A, B, C, or D using the circuit submitted with the certificate of compliance (see 3.6 herein).
 - (2) $T_A = +125^{\circ}C$, minimum.
- b. Interim and final electrical test parameters shall be as specified in table II herein, except interim electrical parameter tests prior to burn-in are optional at the discretion of the manufacturer.

4.3 Quality conformance inspection. Quality conformance inspection shall be in accordance with method 5005 of MIL-STD-883 including groups A, B, C, and D inspections. The following additional criteria shall apply.

4.3.1 Group A inspection.

- a. Tests shall be as specified in table II herein.
- b. Subgroups 5 and 6 in table I, method 5005 of MIL-STD-883 shall be omitted.

STANDARDIZED MILITARY DRAWING DEFENSE ELECTRONICS SUPPLY CENTER DAYTON, OHIO 45444	SIZE A		5962-88575
		REVISION LEVEL	SHEET 12

查询'5962-88575012A'供应商

Subgroups 4, 7, and 8 (input and output measurements) shall be measured only initially and after process or design changes which may affect capacitance. Test all applicable pins on 5 devices with zero failures.

d. Subgroups 7 and 8 tests shall verify the truth table as specified on figure 2.

4.3.2 Groups C and D inspections.

- a. End-point electrical parameters shall be as specified in table II herein.
- b. Steady-state life test conditions, method 1005 of MIL-STD-883.
 - (1) Test condition A, B, C, or D using the circuit submitted with the certificate of compliance (see 3.6 herein).
 - (2) $T_A = +125^\circ\text{C}$, minimum.
 - (3) Test duration: 1,000 hours, except as permitted by method 1005 of MIL-STD-883.

TABLE II. Electrical test requirements.

MIL-STD-883 test requirements	Subgroups (per method 5005, table I)
Interim electrical parameters (method 5004)	---
Final electrical test parameters (method 5004)	1*, 2, 3, 7 8, 9, 10, 11
Group A test requirements (method 5005)	1, 2, 3, 4, 7, 8, 9, 10, 11
Groups C and D end-point electrical parameters (method 5005)	1, 2, 3

* PDA applies to subgroup 1.

5. PACKAGING

5.1 Packaging requirements. The requirements for packaging shall be in accordance with MIL-M-38510.

6. NOTES

6.1 Intended use. Microcircuits conforming to this drawing are intended for use when military specifications do not exist and qualified military devices that will perform the required function are not available for OEM application. When a military specification exists and the product covered by this drawing has been qualified for listing on QPL-38510, the device specified herein will be inactivated and will not be used for new design. The QPL-38510 product shall be the preferred item for all applications.

6.2 Replaceability. Microcircuits covered by this drawing will replace the same generic device covered by a contractor-prepared specification or drawing.

STANDARDIZED MILITARY DRAWING DEFENSE ELECTRONICS SUPPLY CENTER DAYTON, OHIO 45444	SIZE A	5962-88575	
		REVISION LEVEL	SHEET 13

DESC FORM 193A
SEP 87

* U. S. GOVERNMENT PRINTING OFFICE: 1968-549-904

6.3 Configuration control of SMD's. All proposed changes to existing SMD's will be coordinated with the users of record for the individual documents. This coordination will be accomplished in accordance with MIL-STD-481 using DD Form 1693, Engineering Change Proposal (Short Form).

6.4 Record of users. Military and industry users shall inform Defense Electronics Supply Center when a system application requires configuration control and the applicable SMD. DESC will maintain a record of users and this list will be used for coordination and distribution of changes to the drawings. Users of the drawing covering microelectronics devices (FSC 5962) should contact DESC-ECS, telephone (513)296-6022.

6.5 Comments. Comments on this drawing should be directed to DESC-ECS, Dayton, Ohio 45444, or telephone (513) 296-5375.

6.6 Approved sources of supply. Approved sources of supply are listed in MIL-BUL-103. Additional sources will be added to MIL-BUL-103 as they become available. The vendors listed in MIL-BUL-103 have agreed to this drawing and a certificate of compliance (see 3.6 herein) has been submitted to and accepted by DESC-ECS. The approved source of supply listed below is for information purposes only and is current only to the date of the last action of this document.

Military drawing part number	Vendor CAGE number	Vendor similar part number 1/
5962-8857501KX	61772	IDT54FCT841AEB
5962-8857501LX	61772 9Z527	IDT54FCT841ADB VJ54FCT841AD
5962-88575013X	61772 9Z527	IDT54FCT841ALB VJ54FCT841ADL
5962-8857502KX	61772	IDT54FCT841BEB
5962-8857502LX	61772	IDT54FCT841BDB
5962-88575023X	61772	IDT54FCT841BLB

1/ Caution. Do not use this number for item acquisition. Items acquired to this number may not satisfy the performance requirements of this drawing.

Vendor CAGE number

Vendor name and address

61772

Integrated Device Technology
3236 Scott Boulevard
Santa Clara, CA 95052

9Z527

VTC Incorporated
2401 East 86th Street
Bloomington, MN 55420

STANDARDIZED MILITARY DRAWING DEFENSE ELECTRONICS SUPPLY CENTER DAYTON, OHIO 45444	SIZE A	5962-88575
	REVISION LEVEL	SHEET 14

DESC FORM 193A
SEP 87

U. S. GOVERNMENT PRINTING OFFICE: 1988-540-904