

### FEATURES

- **Controlled Baseline**
  - One Assembly Site
  - One Test Site
  - One Fabrication Site
- **Extended Temperature Performance of –55°C to 125°C**
- **Enhanced Diminishing Manufacturing Sources (DMS) Support**
- **Enhanced Product-Change Notification**
- **Qualification Pedigree <sup>(1)</sup>**
- **Bidirectional Voltage Translator**
- **4.5 V to 5.5 V on A Port and 2.7 V to 5.5 V on B Port**
- **Control Inputs  $V_{IH}/V_{IL}$  Levels Are Referenced to  $V_{CCA}$  Voltage**
- **Latch-Up Performance Exceeds 250 mA Per JESD 17**
- **ESD Protection Exceeds JESD 22**
  - 2000-V Human-Body Model (A114-A)
  - 200-V Machine Model (A115-A)
  - 1000-V Charged-Device Model (C101)

(1) Component qualification in accordance with JEDEC and industry standards to ensure reliable operation over an extended temperature range. This includes, but is not limited to, Highly Accelerated Stress Test (HAST) or biased 85/85, temperature cycle, autoclave or unbiased HAST, electromigration, bond intermetallic life, and mold compound life. Such qualification testing should not be viewed as justifying use of this component beyond specified performance and environmental limits.

PW PACKAGE  
(TOP VIEW)

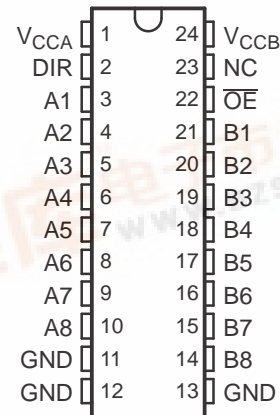

NC – No internal connection

### DESCRIPTION/ORDERING INFORMATION

The SN74LVCC4245A is an 8-bit (octal) noninverting bus transceiver that uses two separate power-supply rails. The A port ( $V_{CCA}$ ) is dedicated to accepting a 5-V supply level, and the configurable B port, which is designed to track  $V_{CCB}$ , accepts voltages from 3 V to 5 V. This allows for translation from a 3.3-V to a 5-V environment and vice versa.

The SN74LVCC4245A is designed for asynchronous communication between data buses. The device transmits data from the A bus to the B bus or from the B bus to the A bus, depending on the logic level at the direction-control (DIR) input. The output-enable ( $\overline{OE}$ ) input can be used to disable the device so the buses effectively are isolated. The control circuitry (DIR,  $\overline{OE}$ ) is powered by  $V_{CCA}$ .

### ORDERING INFORMATION<sup>(1)</sup>

$T_A$	PACKAGE <sup>(2)</sup>	ORDERABLE PART NUMBER	TOP-SIDE MARKING
–55 °C to 125 °C	TSSOP – PW Reel of 2000	CLVCC4245AMPWREP	LG245A-EP

(1) For the most current package and ordering information, see the Package Option Addendum at the end of this document, or see the TI Web site at [www.ti.com](http://www.ti.com).

(2) Package drawings, standard packing quantities, thermal data, symbolization, and PCB design guidelines are available at [www.ti.com/sc/package](http://www.ti.com/sc/package).



Please be aware that an important notice concerning availability, standard warranty, and use in critical applications of Texas Instruments semiconductor products and disclaimers thereto appears at the end of this data sheet.

# SN74LVCC4245A-EP OCTAL DUAL-SUPPLY BUS TRANSCEIVER WITH CONFIGURABLE OUTPUT VOLTAGE AND 3-STATE OUTPUTS

SCAS800-3/MARCH 2007 查询"SN74LVCC4245A-EP"供应商

**FUNCTION TABLE  
(EACH TRANSCEIVER)**

INPUTS		OPERATION
$\overline{OE}$	DIR	
L	L	B data to A bus
L	H	A data to B bus
H	X	Isolation

**LOGIC DIAGRAM (POSITIVE LOGIC)**

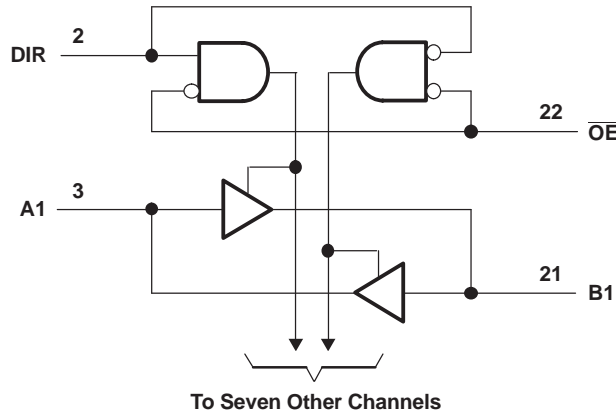

## Absolute Maximum Ratings<sup>(1)</sup>

over operating free-air temperature range (unless otherwise noted)

		MIN	MAX	UNIT	
$V_{CCA}$ $V_{CCB}$	Supply voltage range	-0.5	6	V	
$V_I$	Input voltage range <sup>(2)</sup>	I/O ports (A port)	-0.5	$V_{CCA} + 0.5$	V
		I/O ports (B port)	-0.5	$V_{CCB} + 0.5$	
		Except I/O ports	-0.5	$V_{CCA} + 0.5$	
$V_O$	Output voltage range <sup>(2)</sup>	A port	-0.5	$V_{CCA} + 0.5$	V
		B port	-0.5	$V_{CCB} + 0.5$	
$I_{IK}$	Input clamp current		$V_I < 0$ V	-50	mA
$I_{OK}$	Output clamp current		$V_O < 0$ V	-50	mA
$I_O$	Continuous output current			$\pm 50$	mA
	Continuous current through $V_{CCA}$ , $V_{CCB}$ , or GND			$\pm 100$	mA
$\theta_{JA}$	Package thermal impedance <sup>(3)</sup>			88	$^{\circ}\text{C}/\text{W}$
$T_{stg}$	Storage temperature range	-65	150	$^{\circ}\text{C}$	

(1) Stresses beyond those listed under "absolute maximum ratings" may cause permanent damage to the device. These are stress ratings only, and functional operation of the device at these or any other conditions beyond those indicated under "recommended operating conditions" is not implied. Exposure to absolute-maximum-rated conditions for extended periods may affect device reliability.

(2) This value is limited to 6 V maximum.

(3) The package thermal impedance is calculated in accordance with JESD 51-7.

Recommended Operating Conditions<sup>(1)</sup>

		V <sub>CCA</sub>	V <sub>CCB</sub>	MIN	NOM	MAX	UNIT
V <sub>CCA</sub>	Supply voltage			4.5	5	5.5	V
V <sub>CCB</sub>				2.7	3.3	5.5	
V <sub>IHA</sub>	High-level input voltage	4.5 V	2.7 V	2			V
			3.6 V	2			
		5.5 V	5.5 V	2			
V <sub>IHB</sub>	High-level input voltage	4.5 V	2.7 V	2			V
			3.6 V	2			
		5.5 V	5.5 V	3.85			
V <sub>ILA</sub>	Low-level input voltage	4.5 V	2.7 V			0.8	V
			3.6 V			0.8	
		5.5 V	5.5 V			0.8	
V <sub>ILB</sub>	Low-level input voltage	4.5 V	2.7 V			0.8	V
			3.6 V			0.8	
		5.5 V	5.5 V			1.65	
V <sub>IH</sub>	High-level input voltage (control pins) (referenced to V <sub>CCA</sub> )	4.5 V	2.7 V	2			V
			3.6 V	2			
		5.5 V	5.5 V	2			
V <sub>IL</sub>	Low-level input voltage (control pins) (referenced to V <sub>CCA</sub> )	4.5 V	2.7 V			0.8	V
			3.6 V			0.8	
		5.5 V	5.5 V			0.8	
V <sub>IA</sub>	Input voltage			0		V <sub>CCA</sub>	V
V <sub>IB</sub>	Input voltage			0		V <sub>CCB</sub>	V
V <sub>OA</sub>	Output voltage			0		V <sub>CCA</sub>	V
V <sub>OB</sub>	Output voltage			0		V <sub>CCB</sub>	V
I <sub>OHA</sub>	High-level output current	4.5 V	3 V			–24	mA
I <sub>OHB</sub>	High-level output current	4.5 V	2.7 V to 4.5 V			–24	mA
I <sub>OLA</sub>	Low-level output current	4.5 V	3 V			24	mA
I <sub>OLB</sub>	Low-level output current	4.5 V	2.7 V to 4.5 V			24	mA
T <sub>A</sub>	Operating free-air temperature			–55		125	°C

(1) All unused inputs of the device must be held at the associated V<sub>CC</sub> or GND to ensure proper device operation. See the TI application report, *Implications of Slow or Floating CMOS Inputs*, literature number SCBA004.

# SN74LVCC4245A-EP OCTAL DUAL-SUPPLY BUS TRANSCEIVER WITH CONFIGURABLE OUTPUT VOLTAGE AND 3-STATE OUTPUTS

SCAS800-3/MARCH 2007 查询"SN74LVCC4245A-EP"供应商

## Electrical Characteristics

over recommended operating free-air temperature range (unless otherwise noted)

PARAMETER		TEST CONDITIONS	V <sub>CCA</sub>	V <sub>CCB</sub>	MIN	TYP	MAX	UNIT
V <sub>OHA</sub>		I <sub>OH</sub> = -100 μA	4.5 V	3 V	4.4	4.49		V
		I <sub>OH</sub> = -24 mA			3.76	4.25		
V <sub>OHB</sub>		I <sub>OH</sub> = -100 μA	4.5 V	3 V	2.9	2.99		V
		I <sub>OH</sub> = -12 mA	4.5 V	2.7 V	2.2	2.5		
				3 V	2.46	2.85		
		I <sub>OH</sub> = -24 mA	4.5 V	2.7 V	2.1	2.3		
				3 V	2.25	2.65		
4.5 V	3.76	4.25						
V <sub>OLA</sub>		I <sub>OL</sub> = 100 μA	4.5 V	3 V			0.1	V
		I <sub>OL</sub> = 24 mA			0.21	0.44		
V <sub>OLB</sub>		I <sub>OL</sub> = 100 μA	4.5 V	3 V			0.1	V
		I <sub>OL</sub> = 12 mA	4.5 V	2.7 V	0.11	0.44		
				3 V	0.22	0.5		
		I <sub>OL</sub> = 24 mA	4.5 V	3 V	0.21	0.44		
4.5 V	0.18			0.44				
I <sub>I</sub>	Control inputs	V <sub>I</sub> = V <sub>CCA</sub> or GND	5.5 V	3.6 V	±0.1	±1	μA	
				5.5 V	±0.1	±1		
I <sub>OZ</sub> <sup>(1)</sup>	A or B port	V <sub>O</sub> = V <sub>CCA/B</sub> or GND, V <sub>I</sub> = V <sub>IL</sub> or V <sub>IH</sub>	5.5 V	3.6 V	±0.5	±5	μA	
I <sub>CCA</sub>	B to A	A <sub>n</sub> = V <sub>CC</sub> or GND	5.5 V	Open	8	80	μA	
		I <sub>O</sub> (A port) = 0, B <sub>n</sub> = V <sub>CCB</sub> or GND	5.5 V	3.6 V	8	80		
I <sub>CCB</sub>	A to B	A <sub>n</sub> = V <sub>CCA</sub> or GND, I <sub>O</sub> (B port) = 0	5.5 V	3.6 V	5	50	μA	
				5.5 V	8	80		
ΔI <sub>CCA</sub> <sup>(2)</sup>	A port	V <sub>I</sub> = V <sub>CCA</sub> - 2.1 V, Other inputs at V <sub>CCA</sub> or GND, $\overline{OE}$ at GND and DIR at V <sub>CCA</sub>	5.5 V	5.5 V	1.35	1.5	mA	
	$\overline{OE}$	V <sub>I</sub> = V <sub>CCA</sub> - 2.1 V, Other inputs at V <sub>CCA</sub> or GND, DIR at V <sub>CCA</sub> or GND	5.5 V	5.5 V	1	1.5		
	DIR	V <sub>I</sub> = V <sub>CCA</sub> - 2.1 V, Other inputs at V <sub>CCA</sub> or GND, $\overline{OE}$ at V <sub>CCA</sub> or GND	5.5 V	3.6 V	1	1.5		
ΔI <sub>CCB</sub> <sup>(2)</sup>	B port	V <sub>I</sub> = V <sub>CCB</sub> - 0.6 V, Other inputs at V <sub>CCB</sub> or GND, $\overline{OE}$ at GND and DIR at GND	5.5 V	3.6 V	0.35	0.5	mA	
C <sub>i</sub>	Control inputs	V <sub>I</sub> = V <sub>CCA</sub> or GND	Open	Open	5		pF	
C <sub>io</sub>	A or B port	V <sub>O</sub> = V <sub>CCA/B</sub> or GND	5 V	3.3 V	11		pF	

(1) For I/O ports, the parameter I<sub>OZ</sub> includes the input leakage current.

(2) This is the increase in supply current for each input that is at one of the specified TTL voltage levels, rather than 0 V or the associated V<sub>CC</sub>.

### Switching Characteristics

over recommended operating free-air temperature range,  $C_L = 50$  pF (unless otherwise noted) (see Figure 1 through Figure 4)

PARAMETER	FROM (INPUT)	TO (OUTPUT)	$V_{CCA} = 5\text{ V} \pm 0.5\text{ V}$ , $V_{CCB} = 5\text{ V} \pm 0.5\text{ V}$		$V_{CCA} = 5\text{ V} \pm 0.5\text{ V}$ , $V_{CCB} = 2.7\text{ V to } 3.6\text{ V}$		UNIT
			MIN	MAX	MIN	MAX	
$t_{PHL}$	A	B	1	7.1	1	7	ns
$t_{PLH}$			1	6	1	7	
$t_{PHL}$	B	A	1	6.8	1	6.2	ns
$t_{PLH}$			1	6.1	1	5.3	
$t_{PZL}$	$\overline{OE}$	A	1	9	1	9	ns
$t_{PZH}$			1	8.3	1	8	
$t_{PZL}$	$\overline{OE}$	B	1	8.2	1	10	ns
$t_{PZH}$			1	8.1	1	10.2	
$t_{PLZ}$	$\overline{OE}$	A	1	5.5	1	5.9	ns
$t_{PHZ}$			1	5.7	1	5.9	
$t_{PLZ}$	$\overline{OE}$	B	1	6.4	1	6.4	ns
$t_{PHZ}$			1	7.8	1	8.9	

### Operating Characteristics

$V_{CCA} = 5\text{ V}$ ,  $V_{CCB} = 3.3\text{ V}$ ,  $T_A = 25\text{ }^\circ\text{C}$

PARAMETER		TEST CONDITIONS	TYP	UNIT
$C_{pd}$	Power dissipation capacitance per transceiver	Outputs enabled	20	pF
		Outputs disabled	6.5	

### Power-Up Considerations<sup>(1)</sup>

TI level-translation devices offer an opportunity for successful mixed-voltage signal design. A proper power-up sequence should always be followed to avoid excessive supply current, bus contention, oscillations, or other anomalies caused by improperly biased device pins. Take the following precautions to guard against such power-up problems:

1. Connect ground before any supply voltage is applied.
2. Power up the control side of the device ( $V_{CCA}$  for all four of these devices).
3. Tie  $\overline{OE}$  to  $V_{CCA}$  with a pullup resistor so that it ramps with  $V_{CCA}$ .
4. Depending on the direction of the data path, DIR can be high or low. If DIR high is needed (A data to B bus), ramp it with  $V_{CCA}$ . Otherwise, keep DIR low.

(1) See the TI application report, *Texas Instruments Voltage-Level-Translation Devices*, literature number SCEA021.

# SN74LVCC4245A-EP OCTAL DUAL-SUPPLY BUS TRANSCEIVER WITH CONFIGURABLE OUTPUT VOLTAGE AND 3-STATE OUTPUTS

SCAS890-3/MARCH 2007 查询"SN74LVCC4245A-EP"供应商

## PARAMETER MEASUREMENT INFORMATION FOR A TO B $V_{CCA} = 4.5\text{ V to }5.5\text{ V}$ and $V_{CCB} = 2.7\text{ V to }3.6\text{ V}$

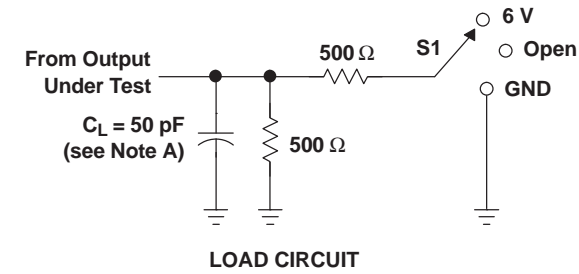

TEST	S1
$t_{PLH}/t_{PHL}$	Open
$t_{PLZ}/t_{PZL}$	6 V
$t_{PHZ}/t_{PZH}$	GND

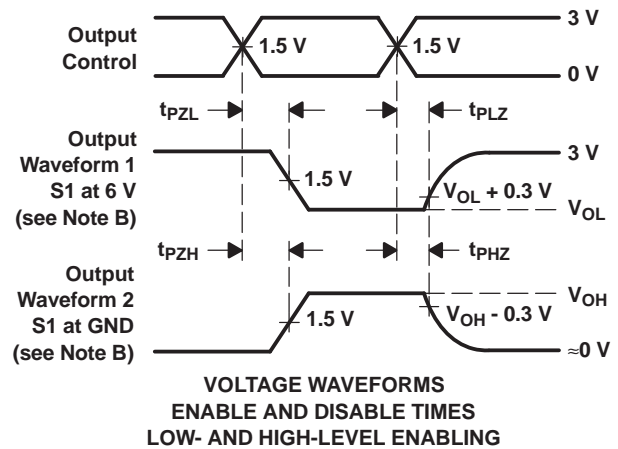
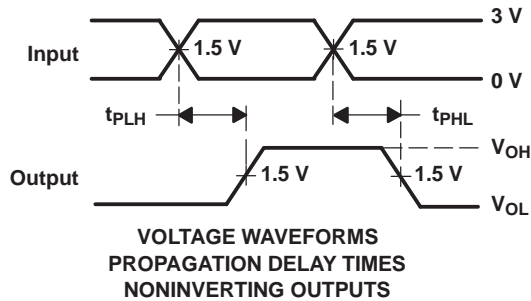
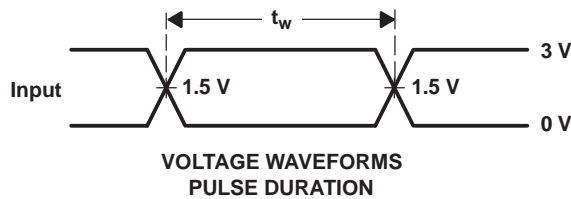

- NOTES: A.  $C_L$  includes probe and jig capacitance.  
B. Waveform 1 is for an output with internal conditions such that the output is low, except when disabled by the output control. Waveform 2 is for an output with internal conditions such that the output is high, except when disabled by the output control.  
C. All input pulses are supplied by generators having the following characteristics:  $PRR \leq 10\text{ MHz}$ ,  $Z_O = 50\ \Omega$ ,  $t_r \leq 2.5\text{ ns}$ ,  $t_f \leq 2.5\text{ ns}$ .  
D. The outputs are measured one at a time, with one transition per measurement.  
E. All parameters and waveforms are not applicable to all devices.

Figure 1. Load Circuit and Voltage Waveforms

PARAMETER MEASUREMENT INFORMATION FOR A TO B  
 $V_{CCA} = 4.5\text{ V to }5.5\text{ V}$  and  $V_{CCB} = 3.6\text{ V to }5.5\text{ V}$

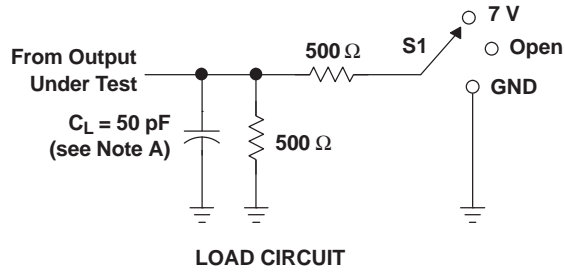

TEST	S1
$t_{PLH}/t_{PHL}$	Open
$t_{PLZ}/t_{PZL}$	7 V
$t_{PHZ}/t_{PZH}$	GND

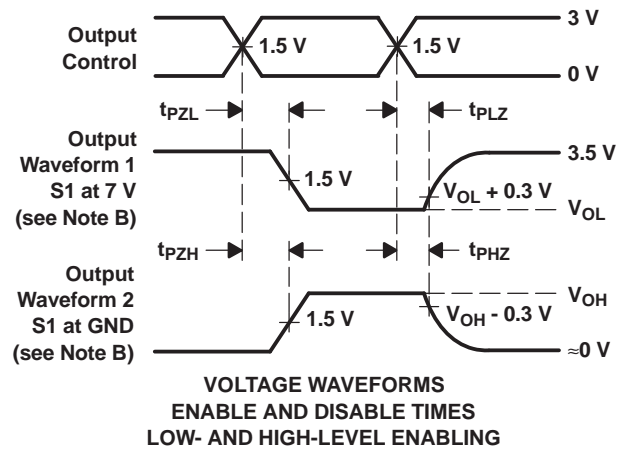
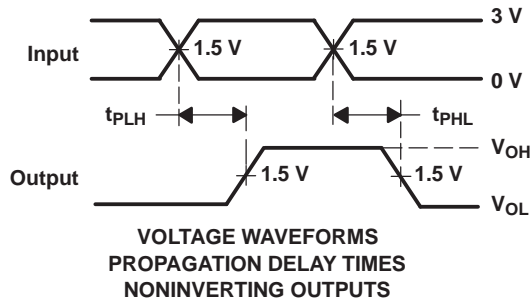
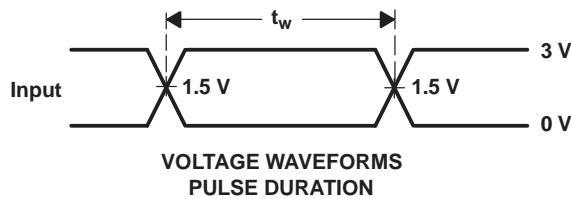

- NOTES: A.  $C_L$  includes probe and jig capacitance.  
 B. Waveform 1 is for an output with internal conditions such that the output is low, except when disabled by the output control. Waveform 2 is for an output with internal conditions such that the output is high, except when disabled by the output control.  
 C. All input pulses are supplied by generators having the following characteristics:  $PRR \leq 10\text{ MHz}$ ,  $Z_O = 50\ \Omega$ ,  $t_r \leq 2.5\text{ ns}$ ,  $t_f \leq 2.5\text{ ns}$ .  
 D. The outputs are measured one at a time, with one transition per measurement.  
 E. All parameters and waveforms are not applicable to all devices.

Figure 2. Load Circuit and Voltage Waveforms

# SN74LVCC4245A-EP OCTAL DUAL-SUPPLY BUS TRANSCEIVER WITH CONFIGURABLE OUTPUT VOLTAGE AND 3-STATE OUTPUTS

SCAS890-3/MARCH 2007 查询"SN74LVCC4245A-EP"供应商

## PARAMETER MEASUREMENT INFORMATION FOR B TO A $V_{CCA} = 4.5\text{ V to }5.5\text{ V}$ and $V_{CCB} = 2.7\text{ V to }3.6\text{ V}$

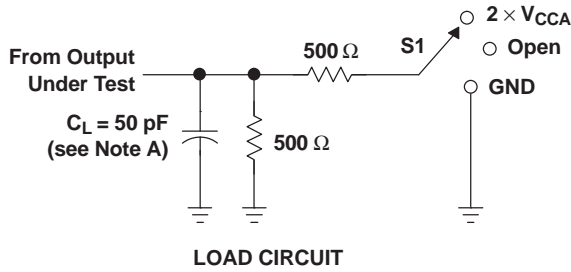

TEST	S1
$t_{PLH}/t_{PHL}$	Open
$t_{PLZ}/t_{PZL}$	2 $\times V_{CCA}$
$t_{PHZ}/t_{PZH}$	GND

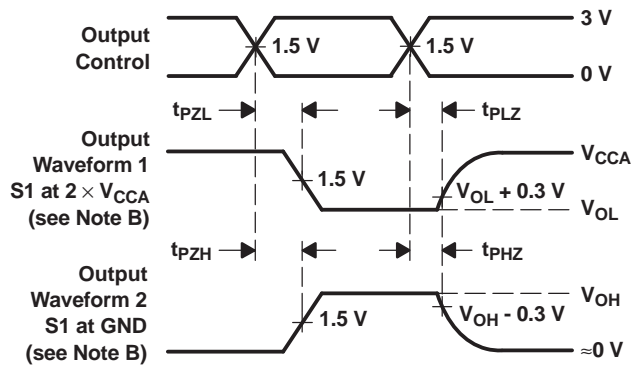
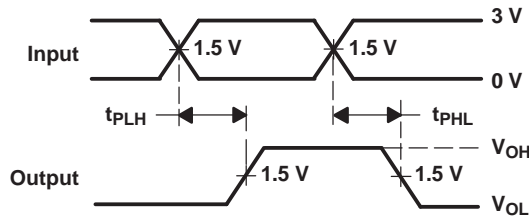
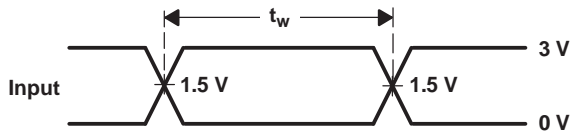

- NOTES: A.  $C_L$  includes probe and jig capacitance.  
B. Waveform 1 is for an output with internal conditions such that the output is low, except when disabled by the output control. Waveform 2 is for an output with internal conditions such that the output is high, except when disabled by the output control.  
C. All input pulses are supplied by generators having the following characteristics: PRR  $\leq 10\text{ MHz}$ ,  $Z_O = 50\ \Omega$ ,  $t_r \leq 2.5\text{ ns}$ ,  $t_f \leq 2.5\text{ ns}$ .  
D. The outputs are measured one at a time, with one transition per measurement.  
E. All parameters and waveforms are not applicable to all devices.

Figure 3. Load Circuit and Voltage Waveforms



PARAMETER MEASUREMENT INFORMATION FOR B TO A  
 $V_{CCA} = 4.5\text{ V to }5.5\text{ V}$  and  $V_{CCB} = 3.6\text{ V to }5.5\text{ V}$

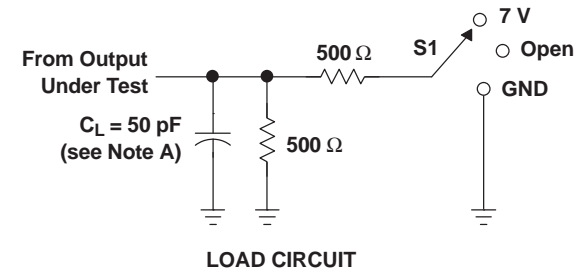

TEST	S1
$t_{PLH}/t_{PHL}$	Open
$t_{PLZ}/t_{PZL}$	7 V
$t_{PHZ}/t_{PZH}$	GND

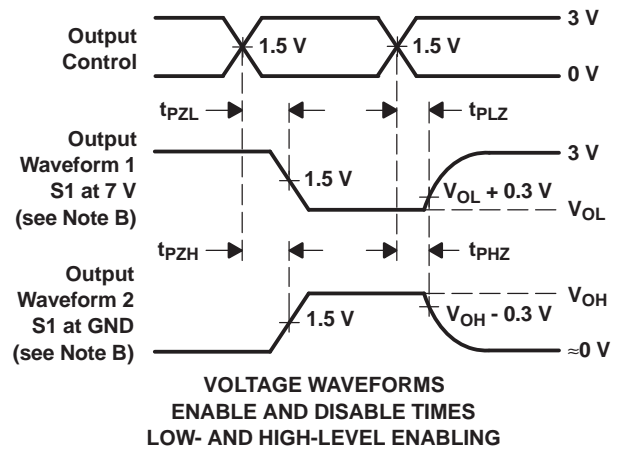
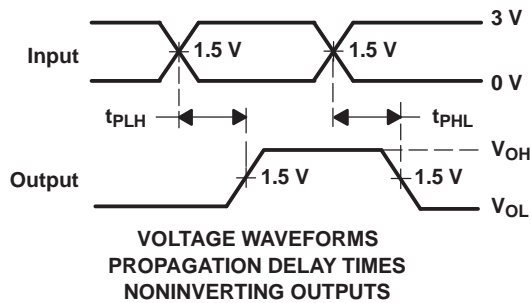
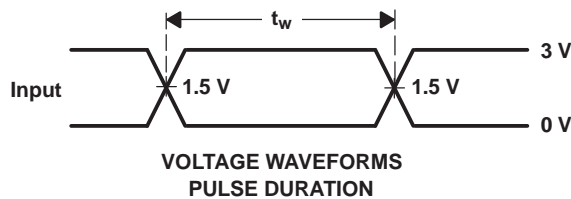

- NOTES:
- $C_L$  includes probe and jig capacitance.
  - Waveform 1 is for an output with internal conditions such that the output is low, except when disabled by the output control. Waveform 2 is for an output with internal conditions such that the output is high, except when disabled by the output control.
  - All input pulses are supplied by generators having the following characteristics:  $PRR \leq 10\text{ MHz}$ ,  $Z_O = 50\ \Omega$ ,  $t_r \leq 2.5\text{ ns}$ ,  $t_f \leq 2.5\text{ ns}$ .
  - The outputs are measured one at a time, with one transition per measurement.
  - All parameters and waveforms are not applicable to all devices.

Figure 4. Load Circuit and Voltage Waveforms

**PACKAGING INFORMATION**

Orderable Device	Status <sup>(1)</sup>	Package Type	Package Drawing	Pins	Package Qty	Eco Plan <sup>(2)</sup>	Lead/Ball Finish	MSL Peak Temp <sup>(3)</sup>
CLVCC4245AMPWREP	ACTIVE	TSSOP	PW	24	2000	Green (RoHS & no Sb/Br)	CU NIPDAU	Level-1-260C-UNLIM
CLVCC4245AMPWREPG4	ACTIVE	TSSOP	PW	24	2000	Green (RoHS & no Sb/Br)	CU NIPDAU	Level-1-260C-UNLIM
V62/06658-01XE	ACTIVE	TSSOP	PW	24	2000	Green (RoHS & no Sb/Br)	CU NIPDAU	Level-1-260C-UNLIM

<sup>(1)</sup> The marketing status values are defined as follows:

**ACTIVE:** Product device recommended for new designs.

**LIFEBUY:** TI has announced that the device will be discontinued, and a lifetime-buy period is in effect.

**NRND:** Not recommended for new designs. Device is in production to support existing customers, but TI does not recommend using this part in a new design.

**PREVIEW:** Device has been announced but is not in production. Samples may or may not be available.

**OBSOLETE:** TI has discontinued the production of the device.

<sup>(2)</sup> Eco Plan - The planned eco-friendly classification: Pb-Free (RoHS), Pb-Free (RoHS Exempt), or Green (RoHS & no Sb/Br) - please check <http://www.ti.com/productcontent> for the latest availability information and additional product content details.

**TBD:** The Pb-Free/Green conversion plan has not been defined.

**Pb-Free (RoHS):** TI's terms "Lead-Free" or "Pb-Free" mean semiconductor products that are compatible with the current RoHS requirements for all 6 substances, including the requirement that lead not exceed 0.1% by weight in homogeneous materials. Where designed to be soldered at high temperatures, TI Pb-Free products are suitable for use in specified lead-free processes.

**Pb-Free (RoHS Exempt):** This component has a RoHS exemption for either 1) lead-based flip-chip solder bumps used between the die and package, or 2) lead-based die adhesive used between the die and leadframe. The component is otherwise considered Pb-Free (RoHS compatible) as defined above.

**Green (RoHS & no Sb/Br):** TI defines "Green" to mean Pb-Free (RoHS compatible), and free of Bromine (Br) and Antimony (Sb) based flame retardants (Br or Sb do not exceed 0.1% by weight in homogeneous material)

<sup>(3)</sup> MSL, Peak Temp. -- The Moisture Sensitivity Level rating according to the JEDEC industry standard classifications, and peak solder temperature.

**Important Information and Disclaimer:** The information provided on this page represents TI's knowledge and belief as of the date that it is provided. TI bases its knowledge and belief on information provided by third parties, and makes no representation or warranty as to the accuracy of such information. Efforts are underway to better integrate information from third parties. TI has taken and continues to take reasonable steps to provide representative and accurate information but may not have conducted destructive testing or chemical analysis on incoming materials and chemicals. TI and TI suppliers consider certain information to be proprietary, and thus CAS numbers and other limited information may not be available for release.

In no event shall TI's liability arising out of such information exceed the total purchase price of the TI part(s) at issue in this document sold by TI to Customer on an annual basis.

**OTHER QUALIFIED VERSIONS OF SN74LVCC4245A-EP :**

- Catalog: [SN74LVCC4245A](#)

NOTE: Qualified Version Definitions:

- Catalog - TI's standard catalog product

TAPE AND REEL INFORMATION

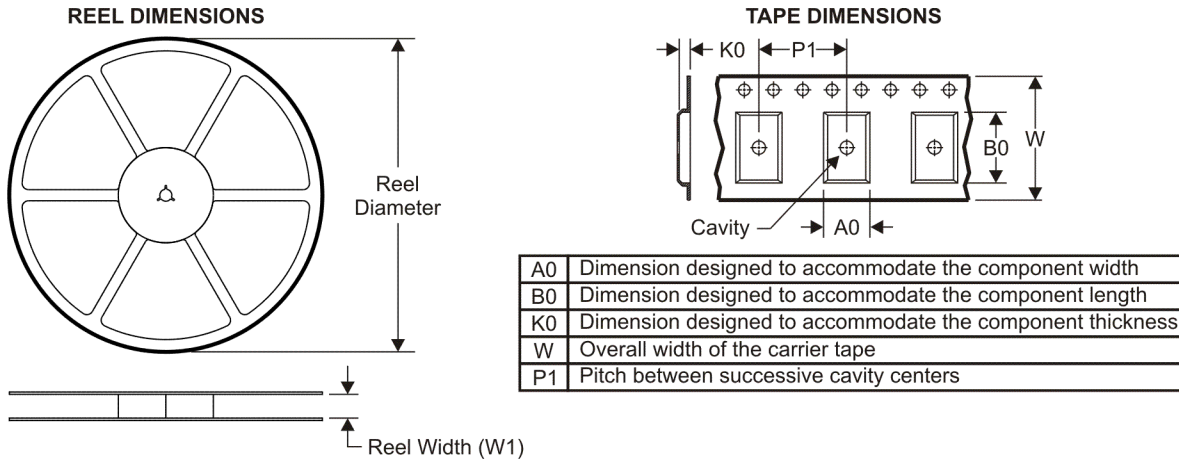

QUADRANT ASSIGNMENTS FOR PIN 1 ORIENTATION IN TAPE

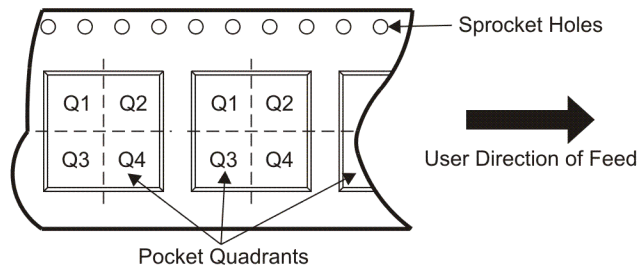

\*All dimensions are nominal

Device	Package Type	Package Drawing	Pins	SPQ	Reel Diameter (mm)	Reel Width W1 (mm)	A0 (mm)	B0 (mm)	K0 (mm)	P1 (mm)	W (mm)	Pin1 Quadrant
CLVCC4245AMPWREP	TSSOP	PW	24	2000	330.0	16.4	6.95	8.3	1.6	8.0	16.0	Q1

**TAPE AND REEL BOX DIMENSIONS**



\*All dimensions are nominal

Device	Package Type	Package Drawing	Pins	SPQ	Length (mm)	Width (mm)	Height (mm)
CLVCC4245AMPWREP	TSSOP	PW	24	2000	346.0	346.0	33.0

PW (R-PDSO-G\*\*)

PLASTIC SMALL-OUTLINE PACKAGE

14 PINS SHOWN

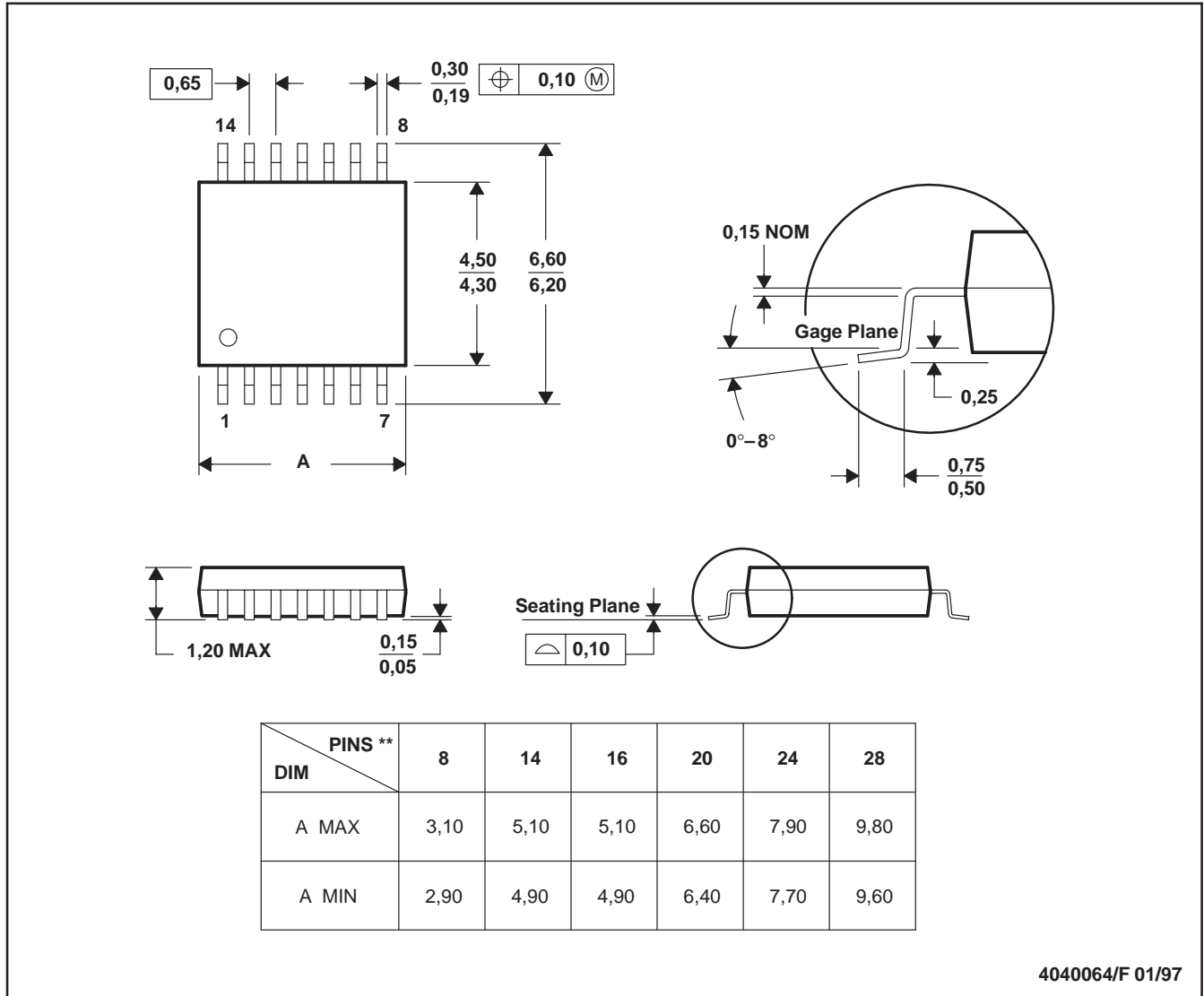

- NOTES: A. All linear dimensions are in millimeters.  
 B. This drawing is subject to change without notice.  
 C. Body dimensions do not include mold flash or protrusion not to exceed 0,15.  
 D. Falls within JEDEC MO-153

## IMPORTANT NOTICE

Texas Instruments Incorporated and its subsidiaries (TI) reserve the right to make corrections, modifications, enhancements, improvements, and other changes to its products and services at any time and to discontinue any product or service without notice. Customers should obtain the latest relevant information before placing orders and should verify that such information is current and complete. All products are sold subject to TI's terms and conditions of sale supplied at the time of order acknowledgment.

TI warrants performance of its hardware products to the specifications applicable at the time of sale in accordance with TI's standard warranty. Testing and other quality control techniques are used to the extent TI deems necessary to support this warranty. Except where mandated by government requirements, testing of all parameters of each product is not necessarily performed.

TI assumes no liability for applications assistance or customer product design. Customers are responsible for their products and applications using TI components. To minimize the risks associated with customer products and applications, customers should provide adequate design and operating safeguards.

TI does not warrant or represent that any license, either express or implied, is granted under any TI patent right, copyright, mask work right, or other TI intellectual property right relating to any combination, machine, or process in which TI products or services are used. Information published by TI regarding third-party products or services does not constitute a license from TI to use such products or services or a warranty or endorsement thereof. Use of such information may require a license from a third party under the patents or other intellectual property of the third party, or a license from TI under the patents or other intellectual property of TI.

Reproduction of TI information in TI data books or data sheets is permissible only if reproduction is without alteration and is accompanied by all associated warranties, conditions, limitations, and notices. Reproduction of this information with alteration is an unfair and deceptive business practice. TI is not responsible or liable for such altered documentation. Information of third parties may be subject to additional restrictions.

Resale of TI products or services with statements different from or beyond the parameters stated by TI for that product or service voids all express and any implied warranties for the associated TI product or service and is an unfair and deceptive business practice. TI is not responsible or liable for any such statements.

TI products are not authorized for use in safety-critical applications (such as life support) where a failure of the TI product would reasonably be expected to cause severe personal injury or death, unless officers of the parties have executed an agreement specifically governing such use. Buyers represent that they have all necessary expertise in the safety and regulatory ramifications of their applications, and acknowledge and agree that they are solely responsible for all legal, regulatory and safety-related requirements concerning their products and any use of TI products in such safety-critical applications, notwithstanding any applications-related information or support that may be provided by TI. Further, Buyers must fully indemnify TI and its representatives against any damages arising out of the use of TI products in such safety-critical applications.

TI products are neither designed nor intended for use in military/aerospace applications or environments unless the TI products are specifically designated by TI as military-grade or "enhanced plastic." Only products designated by TI as military-grade meet military specifications. Buyers acknowledge and agree that any such use of TI products which TI has not designated as military-grade is solely at the Buyer's risk, and that they are solely responsible for compliance with all legal and regulatory requirements in connection with such use.

TI products are neither designed nor intended for use in automotive applications or environments unless the specific TI products are designated by TI as compliant with ISO/TS 16949 requirements. Buyers acknowledge and agree that, if they use any non-designated products in automotive applications, TI will not be responsible for any failure to meet such requirements.

Following are URLs where you can obtain information on other Texas Instruments products and application solutions:

<b>Products</b>		<b>Applications</b>	
Amplifiers	<a href="http://amplifier.ti.com">amplifier.ti.com</a>	Audio	<a href="http://www.ti.com/audio">www.ti.com/audio</a>
Data Converters	<a href="http://dataconverter.ti.com">dataconverter.ti.com</a>	Automotive	<a href="http://www.ti.com/automotive">www.ti.com/automotive</a>
DLP® Products	<a href="http://www.dlp.com">www.dlp.com</a>	Communications and Telecom	<a href="http://www.ti.com/communications">www.ti.com/communications</a>
DSP	<a href="http://dsp.ti.com">dsp.ti.com</a>	Computers and Peripherals	<a href="http://www.ti.com/computers">www.ti.com/computers</a>
Clocks and Timers	<a href="http://www.ti.com/clocks">www.ti.com/clocks</a>	Consumer Electronics	<a href="http://www.ti.com/consumer-apps">www.ti.com/consumer-apps</a>
Interface	<a href="http://interface.ti.com">interface.ti.com</a>	Energy	<a href="http://www.ti.com/energy">www.ti.com/energy</a>
Logic	<a href="http://logic.ti.com">logic.ti.com</a>	Industrial	<a href="http://www.ti.com/industrial">www.ti.com/industrial</a>
Power Mgmt	<a href="http://power.ti.com">power.ti.com</a>	Medical	<a href="http://www.ti.com/medical">www.ti.com/medical</a>
Microcontrollers	<a href="http://microcontroller.ti.com">microcontroller.ti.com</a>	Security	<a href="http://www.ti.com/security">www.ti.com/security</a>
RFID	<a href="http://www.ti-rfid.com">www.ti-rfid.com</a>	Space, Avionics & Defense	<a href="http://www.ti.com/space-avionics-defense">www.ti.com/space-avionics-defense</a>
RF/IF and ZigBee® Solutions	<a href="http://www.ti.com/lprf">www.ti.com/lprf</a>	Video and Imaging	<a href="http://www.ti.com/video">www.ti.com/video</a>
		Wireless	<a href="http://www.ti.com/wireless-apps">www.ti.com/wireless-apps</a>