

REVISIONS

LTR	DESCRIPTION	DATE (YR-MO-DA)	APPROVED
	<a href="#">查询 5962-9669801QXA 供应商</a>		

REV																				
SHEET																				
REV																				
SHEET	15	16	17	18	19	20	21	22	23	24	25	26	27	28						

REV STATUS OF SHEETS	REV																			
	SHEET	1	2	3	4	5	6	7	8	9	10	11	12	13	14					

PMIC N/A	PREPARED BY Joseph A. Kerby	DEFENSE ELECTRONICS SUPPLY CENTER DAYTON, OHIO 45444		
<b>STANDARD MICROCIRCUIT DRAWING</b>  THIS DRAWING IS AVAILABLE FOR USE BY ALL DEPARTMENTS AND AGENCIES OF THE DEPARTMENT OF DEFENSE  AMSC N/A	CHECKED BY Thanh V. Nguyen			MICROCIRCUIT, DIGITAL, ADVANCED BIPOLAR CMOS, SCAN TEST DEVICE WITH 18-BIT TRANSCEIVER/ REGISTER, THREE-STATE OUTPUTS, TTL COMPATIBLE INPUTS, MONOLITHIC SILICON
	APPROVED BY Monica L. Poelking			
	DRAWING APPROVAL DATE 96-02-01	SIZE <b>A</b>	CAGE CODE <b>67268</b>	
	REVISION LEVEL	SHEET 1 OF 28		

1. SCOPE

1.1 Scope. This drawing documents the product assurance class levels consisting of high reliability (device classes Q and M) and space application (device class V). A choice of case outlines and lead finishes are available and are reflected in the Part or Identifying Number (PIN). When available, a choice of Radiation Hardness Assurance (RHA) levels are reflected in the PIN.

1.2 PIN. The PIN is as shown in the following example:

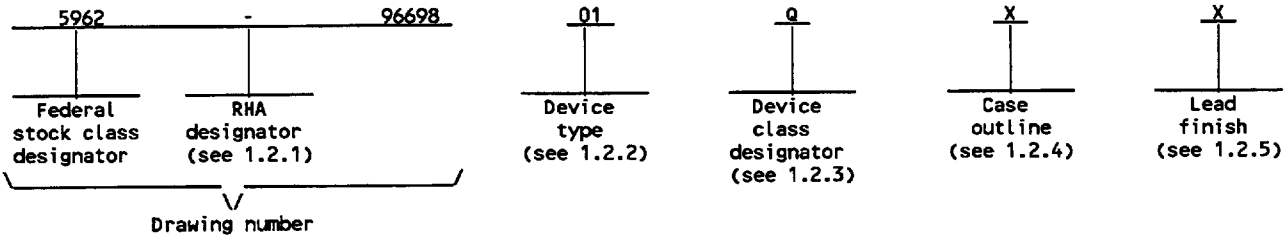

1.2.1 RHA designator. Device classes Q and V RHA marked devices meet the MIL-PRF-38535 specified RHA levels and are marked with the appropriate RHA designator. Device class M RHA marked devices meet the MIL-PRF-38535, appendix A specified RHA levels and are marked with the appropriate RHA designator. A dash (-) indicates a non-RHA device.

1.2.2 Device type(s). The device type(s) identify the circuit function as follows:

<u>Device type</u>	<u>Generic number</u>	<u>Circuit function</u>
01	54ABTH18646A	Scan test device with 18-bit transceiver and register, three-state outputs, TTL compatible inputs

1.2.3 Device class designator. The device class designator is a single letter identifying the product assurance level as follows:

<u>Device class</u>	<u>Device requirements documentation</u>
M	Vendor self-certification to the requirements for MIL-STD-883 compliant, non-JAN class level B microcircuits in accordance with MIL-PRF-38535, appendix A
Q or V	Certification and qualification to MIL-PRF-38535

1.2.4 Case outline(s). The case outline(s) are as designated in MIL-STD-1835 and as follows:

<u>Outline letter</u>	<u>Descriptive designator</u>	<u>Terminals</u>	<u>Package style</u>
X	See figure 1	68	Quad flat Package

1.2.5 Lead finish. The lead finish is as specified in MIL-PRF-38535 for device classes Q and V or MIL-PRF-38535, appendix A for device class M.

<b>STANDARD MICROCIRCUIT DRAWING DEFENSE ELECTRONICS SUPPLY CENTER DAYTON, OHIO 45444</b>	<b>SIZE A</b>		<b>5962-96698</b>
		<b>REVISION LEVEL</b>	<b>SHEET 2</b>

1.3 Absolute maximum ratings. 1/ 2/ 3/

Supply Voltage Range (V<sub>CC</sub>) . . . . . -0.5 V dc to +7.0 V dc

DC input voltage range (except I/O ports) (V<sub>IN</sub>) . . . . . -0.5 V dc to +7.0 V dc 4/

DC input voltage range (I/O ports) (V<sub>IN</sub>) . . . . . -0.5 V dc to +5.5 V dc 4/

DC output voltage range (V<sub>OUT</sub>) . . . . . -0.5 V dc to +5.5 V dc 4/

DC output current (I<sub>OL</sub>) (per output) (A port or TDO) . . . . . +96 mA

DC output current (I<sub>OL</sub>) (per output) (B port) . . . . . +30 mA

DC input clamp current (I<sub>IK</sub>) (V<sub>IN</sub> < 0.0 V) . . . . . -18 mA

DC output clamp current (I<sub>OK</sub>) (V<sub>OUT</sub> < 0.0 V) . . . . . -50 mA

Storage temperature range (T<sub>STG</sub>) . . . . . -65°C to +150°C

Lead temperature (soldering, 10 seconds) . . . . . +300°C

Thermal resistance, junction-to-case (θ<sub>JC</sub>) . . . . . 1.9°C/W

Junction temperature (T<sub>J</sub>) . . . . . +175°C

Maximum power dissipation (P<sub>D</sub>) (at T<sub>A</sub> = 55°C in still air) . . . . . 607 mW 5/

1.4 Recommended operating conditions. 2/ 3/

Supply voltage range (V<sub>CC</sub>) . . . . . +4.5 V dc to +5.5 V dc

Input voltage range (V<sub>IN</sub>) . . . . . +0.0 V dc to V<sub>CC</sub>

Maximum low level input voltage (V<sub>IL</sub>) . . . . . +0.8 V

Minimum high level input voltage (V<sub>IH</sub>) . . . . . +2.0 V

Maximum high level output current (I<sub>OH</sub>) . . . . . -24 mA

Maximum low level output current (I<sub>OL</sub>) . . . . . +48 mA

Maximum input rise or fall rate (Δt/ΔV) . . . . . 10 ns/V

Case operating temperature range (T<sub>C</sub>) . . . . . -55°C to +125°C

1.5 Digital logic testing for device classes Q and V.

Fault coverage measurement of manufacturing logic tests (MIL-STD-883, test method 5012) . . . . . XX percent 6/

- 1/ Stresses above the absolute maximum rating may cause permanent damage to the device. Extended operation at the maximum levels may degrade performance and affect reliability.
- 2/ Unless otherwise noted, all voltages are referenced to GND.
- 3/ The limits for the parameters specified herein shall apply over the full specified V<sub>CC</sub> range and case temperature range of -55°C to +125°C.
- 4/ The input and output negative voltage ratings may be exceeded provided that the input and output clamp current ratings are observed.
- 5/ Power dissipation values are derived using the formula P<sub>D</sub> = V<sub>CC</sub>I<sub>CC</sub> + nV<sub>OL</sub>I<sub>OL</sub>, where V<sub>CC</sub> and I<sub>OL</sub> are as specified in 1.4 above, I<sub>CC</sub> and V<sub>OL</sub> are as specified in table I herein, and n represents the total number of outputs.
- 6/ Values will be added when they become available.

STANDARD MICROCIRCUIT DRAWING DEFENSE ELECTRONICS SUPPLY CENTER DAYTON, OHIO 45444	SIZE <b>A</b>		5962-96698
		REVISION LEVEL	SHEET 3

2. APPLICABLE DOCUMENTS

2.1 Government specification, standards, and handbooks. The following specification, standards, and handbooks form a part of this drawing to the extent specified herein. Unless otherwise specified, the issues of these documents are those listed in the issue of the Department of Defense Index of Specifications and Standards (DoDISS) and supplement thereto, cited in the solicitation.

SPECIFICATION

MILITARY

MIL-PRF-38535 - Integrated Circuits, Manufacturing, General Specification for.

STANDARDS

MILITARY

MIL-STD-883 - Test Methods and Procedures for Microelectronics.  
MIL-STD-973 - Configuration Management.  
MIL-STD-1835 - Microcircuit Case Outlines.

HANDBOOK

MILITARY

MIL-HDBK-103 - List of Standard Microcircuit Drawings (SMD's).  
MIL-HDBK-780 - Standard Microcircuit Drawings.

(Unless otherwise indicated, copies of the specification, standards, and handbooks are available from the Standardization Document Order Desk, 700 Robbins Avenue, Building 4D, Philadelphia, PA 19111-5094.)

2.2 Non-Government publications. The following document(s) form a part of this document to the extent specified herein. Unless otherwise specified, the issues of the documents which are DOD adopted are those listed in the issue of the DoDISS cited in the solicitation. Unless otherwise specified, the issues of documents not listed in the DoDISS are the issues of the documents cited in the solicitation.

INSTITUTE OF ELECTRICAL AND ELECTRONICS ENGINEERS (IEEE)

IEEE Standard 1149.1 - IEEE Standard Test Access Port and Boundary Scan Architecture.

(Applications for copies should be addressed to the Institute of Electrical and Electronics Engineers, 445 Hoes Lane, Piscataway, NJ 08854-4150.)

(Non-Government standards and other publications are normally available from the organizations that prepare or distribute the documents. These documents may also be available in or through libraries or other informational services.)

2.3 Order of precedence. In the event of a conflict between the text of this drawing and the references cited herein, the text of this drawing takes precedence. Nothing in this document, however, supersedes applicable laws and regulations unless a specific exemption has been obtained.

3. REQUIREMENTS

3.1 Item requirements. The individual item requirements for device classes Q and V shall be in accordance with MIL-PRF-38535 and as specified herein or as modified in the device manufacturer's Quality Management (QM) plan. The modification in the QM plan shall not affect the form, fit, or function as described herein. The individual item requirements for device class M shall be in accordance with MIL-PRF-38535, appendix A for non-JAN class level B devices and as specified herein.

3.2 Design, construction, and physical dimensions. The design, construction, and physical dimensions shall be as specified in MIL-PRF-38535 and herein for device classes Q and V or MIL-PRF-38535, appendix A and herein for device class M.

3.2.1 Case outline. The case outline shall be in accordance with 1.2.4 herein and figure 1.

3.2.2 Terminal connections. The terminal connections shall be as specified on figure 2.

3.2.3 Truth table. The truth table shall be as specified on figure 3.

STANDARD MICROCIRCUIT DRAWING DEFENSE ELECTRONICS SUPPLY CENTER DAYTON, OHIO 45444	SIZE A		5962-96698
		REVISION LEVEL	SHEET 4

DESC FORM 193A  
JUL 94

9004708 0019489 749

3.2.4 Block diagram. The block diagram shall be as specified on figure 4.

3.2.5 Test access port controller and scan test registers The test access port (TAP) controller and scan test registers shall be as specified on figure 5.

3.2.6 Ground bounce load circuit and wave forms The ground bounce load circuit and wave forms shall be as specified on figure 6.

3.2.7 Switching waveforms and test circuit. The switching waveforms and test circuit shall be as specified on figure 7.

3.2.8 Radiation exposure circuit. The radiation exposure circuit shall be as specified when available.

3.3 Electrical performance characteristics and postirradiation parameter limits. Unless otherwise specified herein, the electrical performance characteristics and postirradiation parameter limits are as specified in table I and shall apply over the full case operating temperature.

3.4 Electrical test requirements. The electrical test requirements shall be the subgroups specified in table II. The electrical tests for each subgroup are defined in table I.

3.5 Marking. The part shall be marked with the PIN listed in 1.2 herein. In addition, the manufacturer's PIN may also be marked as listed in MIL-HDBK-103. For packages where marking of the entire SMD PIN number is not feasible due to space limitations, the manufacturer has the option of not marking the "5962-" on the device. For RHA product using this option, the RHA designator shall still be marked. Marking for device classes Q and V shall be in accordance with MIL-PRF-38535. Marking for device class M shall be in accordance with MIL-PRF-38535, appendix A.

3.5.1 Certification/compliance mark. The certification mark for device classes Q and V shall be a "QML" or "Q" as required in MIL-PRF-38535. The compliance mark for device class M shall be a "C" as required in MIL-PRF-38535, appendix A.

3.6 Certificate of compliance. For device classes Q and V, a certificate of compliance shall be required from a QML-38535 listed manufacturer in order to supply to the requirements of this drawing (see 6.6.1 herein). For device class M, a certificate of compliance shall be required from a manufacturer in order to be listed as an approved source of supply in MIL-HDBK-103 (see 6.6.2 herein). The certificate of compliance submitted to DESC-EC prior to listing as an approved source of supply for this drawing shall affirm that the manufacturer's product meets, for device classes Q and V, the requirements of MIL-PRF-38535 and herein or for device class M, the requirements of MIL-PRF-38535, appendix A and herein.

3.7 Certificate of conformance. A certificate of conformance as required for device classes Q and V in MIL-PRF-38535 or for device class M in MIL-PRF-38535, appendix A shall be provided with each lot of microcircuits delivered to this drawing.

3.8 Notification of change for device class M. For device class M, notification to DESC-EC of change of product (see 6.2 herein) involving devices acquired to this drawing is required for any change as defined in MIL-STD-973.

3.9 Verification and review for device class M. For device class M, DESC, DESC's agent, and the acquiring activity retain the option to review the manufacturer's facility and applicable required documentation. Offshore documentation shall be made available onshore at the option of the reviewer.

3.10 Microcircuit group assignment for device class M. Device class M devices covered by this drawing shall be in microcircuit group number 126 (see MIL-PRF-38535, appendix A).

3.11 IEEE 1149.1 compliance. This device shall be compliant with IEEE 1149.1.

#### 4. QUALITY ASSURANCE PROVISIONS

4.1 Sampling and inspection. For device classes Q and V, sampling and inspection procedures shall be in accordance with MIL-PRF-38535 or as modified in the device manufacturer's Quality Management (QM) plan. The modification in the QM plan shall not affect the form, fit, or function as described herein. For device class M, sampling and inspection procedures shall be in accordance with MIL-PRF-38535, appendix A.

STANDARD MICROCIRCUIT DRAWING DEFENSE ELECTRONICS SUPPLY CENTER DAYTON, OHIO 45444	SIZE A		5962-96698
		REVISION LEVEL	SHEET 5

DESC FORM 193A  
JUL 94

9004708 0019490 460

TABLE I. Electrical performance characteristics.

Test and MIL-STD-883 test method 1/	Symbol	Test conditions 2/ -55°C ≤ T <sub>C</sub> ≤ +125°C +4.5 V ≤ V <sub>CC</sub> ≤ +5.5 V unless otherwise specified	V <sub>CC</sub>	Group A subgroups	Limits 3/		Unit	
					Min	Max		
Negative input clamp voltage 3022	V <sub>IC-</sub>	For input under test I <sub>IN</sub> = -18 mA	4.5 V	1, 2, 3		-1.2	V	
High level output voltage 3006	V <sub>OH</sub>	For all inputs affecting output under test V <sub>IN</sub> = 2.0 V or 0.8 V	I <sub>OH</sub> = -3.0 mA	4.5 V	1, 2, 3	3		V
				5.0 V	1, 2, 3	3		
			I <sub>OH</sub> = -24.0 mA	4.5 V	1, 2, 3	2		
Low level output voltage 3007	V <sub>OL</sub>	For all inputs affecting output under test V <sub>IN</sub> = 2.0 V or 0.8 V I <sub>OL</sub> = 48 mA	4.5 V	1, 2, 3		0.55	V	
Input current high 3010	I <sub>IH</sub> 4/	For input under test V <sub>IN</sub> = V <sub>CC</sub>	mCLKAB, mCLKBA, mDIR, mSAB, mSBA, or TCK	0.0 V and 5.5 V	1, 2, 3		+1.0	μA
			mAn or mBn ports	5.5 V	1, 2, 3		+20.0	μA
			mOE, TDI, or TMS	5.5 V	1, 2, 3		+10.0	μA
Input current low 3009	I <sub>IL</sub> 4/	For input under test V <sub>IN</sub> = G <sub>ND</sub>	mCLKAB, mCLKBA, mDIR, mSAB, mSBA, or TCK	0.0 V and 5.5 V	1, 2, 3		-1.0	μA
			mAn or mBn ports	5.5 V	1, 2, 3		-20	μA
			mOE, TDI, or TMS	5.5 V	1, 2, 3		-150	μA
Input bus hold current	I <sub>hold</sub> 4/	V <sub>IN</sub> = 0.8 V	mAn or mBn ports	4.5 V		75	500	μA
		V <sub>IN</sub> = 2.0 V				-75	-500	
Three-state output leakage current high (TDO only) 3021	I <sub>OZH</sub>	V <sub>OUT</sub> = 2.7 V, mOE = 2.0 V	5.5 V	1, 2, 3		10	μA	
Three-state output leakage current low (TDO only) 3020	I <sub>OZL</sub>	V <sub>OUT</sub> = 0.5 V, mOE = 2.0 V	5.5 V	1, 2, 3		-10	μA	
Off-state leakage current	I <sub>OFF</sub>	For input or output under test V <sub>IN</sub> or V <sub>OUT</sub> = 4.5 V All other pins at 0.0 V	0.0 V	1			±100	μA
High state leakage current	I <sub>CEX</sub>	For output under test, V <sub>OUT</sub> = 5.5 V Outputs at high logic state	5.5 V	1, 2, 3		50	μA	

See footnotes at end of table.

<b>STANDARD MICROCIRCUIT DRAWING DEFENSE ELECTRONICS SUPPLY CENTER DAYTON, OHIO 45444</b>	<b>SIZE A</b>		<b>5962-96698</b>
		<b>REVISION LEVEL</b>	<b>SHEET 6</b>

TABLE I. Electrical performance characteristics - Continued.

Test and MIL-STD-883 test method 1/	Symbol	Test conditions 2/ -55°C ≤ T <sub>C</sub> ≤ +125°C +4.5 V ≤ V <sub>CC</sub> ≤ +5.5 V unless otherwise specified	V <sub>CC</sub>	Group A subgroups	Limits 3/		Unit
					Min	Max	
Output current 3011	I <sub>OUT</sub> 5/	V <sub>OUT</sub> = 2.5 V	5.5 V	1, 2, 3	-50	-200	mA
Quiescent supply current, outputs high 3005	I <sub>CCH</sub>	For all inputs, V <sub>IN</sub> = V <sub>CC</sub> or GND I <sub>OUT</sub> = 0.0 A mA <sub>n</sub> or mB <sub>n</sub> ports	5.5 V	1, 2, 3		3.9	mA
Quiescent supply current, outputs low 3005	I <sub>CCL</sub>		5.5 V	1, 2, 3		24.0	mA
Quiescent supply current, outputs disabled 3005	I <sub>CCZ</sub>		5.5 V	1, 2, 3		3.0	mA
Quiescent supply current delta, TTL input level 3005	ΔI <sub>CC</sub> 6/	For input under test, V <sub>IN</sub> = 3.4 V For all other inputs V <sub>IN</sub> = V <sub>CC</sub> or GND	5.5 V	1, 2, 3		1.5	mA
Input capacitance 3012	C <sub>IN</sub>	T <sub>C</sub> = +25°C V <sub>IN</sub> = 2.5 V or 0.5 V See 4.4.1c	Control inputs	5.0 V	4		5.5 pF
I/O capacitance 3012	C <sub>I/O</sub>	T <sub>C</sub> = +25°C V <sub>OUT</sub> = 2.5 V or 0.5 V See 4.4.1c	mAn or mBn ports	5.0 V	4		9.0 pF
Output capacitance 3012	C <sub>OUT</sub>		TDO	5.0 V	4		6.0 pF
Low level ground bounce noise	V <sub>OLP</sub> 7/	V <sub>IH</sub> = 3.0 V, V <sub>IL</sub> = 0.0 V T <sub>C</sub> = +25°C See figure 6 See 4.4.1d		5.0 V	4		1700 mV
Low level ground bounce noise	V <sub>OLV</sub> 7/			5.0 V	4		-1500 mV
High level V <sub>CC</sub> bounce noise	V <sub>OHP</sub> 7/			5.0 V	4		1700 mV
High level V <sub>CC</sub> bounce noise	V <sub>OHV</sub> 7/			5.0 V	4		-650 mV
Functional test	8/	V <sub>IH</sub> = 2.0 V, V <sub>IL</sub> = 0.8 V Verify output V <sub>O</sub> See 4.4.1b		4.5 V	7, 8	L	H
				5.5 V	7, 8	L	H

See footnotes at end of table.

STANDARD  
MICROCIRCUIT DRAWING  
DEFENSE ELECTRONICS SUPPLY CENTER  
DAYTON, OHIO 45444

SIZE  
A

5962-96698

REVISION LEVEL

SHEET

7

TABLE I. Electrical performance characteristics - Continued.

Test and MIL-STD-883 test method 1/	Symbol	Test conditions 2/ -55°C ≤ T <sub>C</sub> ≤ +125°C +4.5 V ≤ V <sub>CC</sub> ≤ +5.5 V unless otherwise specified	V <sub>CC</sub>	Group A subgroups	Limits 3/		Unit	
					Min	Max		
NORMAL MODE								
Clock frequency, mCLKAB or mCLKBA	f <sub>clock1</sub>	C <sub>L</sub> = 50 pF minimum R <sub>L</sub> = 500Ω See figure 7	4.5 V and 5.5 V	9, 10, 11	0.0	100	MHz	
	Pulse duration, mCLKAB or mCLKBA high or low				t <sub>w1</sub>	3.0		ns
	Setup time, mAn before mCLKAB <sup>†</sup> or mBn before mCLKBA <sup>†</sup>				t <sub>s1</sub>	3.0		
	Hold time, mAn after mCLKAB <sup>†</sup> or mBn after mCLKBA <sup>†</sup>				t <sub>h1</sub>	0.9		
Maximum clock frequency, mCLKAB or mCLKBA	f <sub>MAX1</sub>	C <sub>L</sub> = 50 pF minimum R <sub>L</sub> = 500Ω See figure 7	5.0 V	9	100		MHz	
			4.5 V and 5.5 V	10, 11	100			
Propagation delay time, mAn to mBn or mBn to mAn 3003	t <sub>PLH1</sub>	C <sub>L</sub> = 50 pF minimum R <sub>L</sub> = 500Ω See figure 7	5.0 V	9	1.5	4.7	ns	
			4.5 V and 5.5 V	10, 11	1.5	5.2		
	t <sub>PHL1</sub>		5.0 V	9	1.5	5.0		
	4.5 V and 5.5 V		10, 11	1.5	6.0			
Propagation delay time, mCLKAB to mBn or mCLKBA to mAn 3003	t <sub>PLH2</sub>	C <sub>L</sub> = 50 pF minimum R <sub>L</sub> = 500Ω See figure 7	5.0 V	9	1.5	5.6	ns	
			4.5 V and 5.5 V	10, 11	1.5	6.8		
	t <sub>PHL2</sub>		5.0 V	9	1.5	5.8		
	4.5 V and 5.5 V		10, 11	1.5	7.0			
Propagation delay time, mSAB to mBn or mSBA to mAn 3003	t <sub>PLH3</sub>	C <sub>L</sub> = 50 pF minimum R <sub>L</sub> = 500Ω See figure 7	5.0 V	9	1.5	6.0	ns	
			4.5 V and 5.5 V	10, 11	1.5	7.8		
	t <sub>PHL3</sub>		5.0 V	9	1.5	6.5		
	4.5 V and 5.5 V		10, 11	1.5	8.2			

See footnotes at end of table.

<b>STANDARD MICROCIRCUIT DRAWING DEFENSE ELECTRONICS SUPPLY CENTER DAYTON, OHIO 45444</b>	<b>SIZE A</b>		<b>5962-96698</b>
		REVISION LEVEL	SHEET <b>8</b>



TABLE I. Electrical performance characteristics - Continued.

Test and MIL-STD-883 test method 1/	Symbol	Test conditions 2/ -55°C ≤ T <sub>C</sub> ≤ +125°C +4.5 V ≤ V <sub>CC</sub> ≤ +5.5 V unless otherwise specified	V <sub>CC</sub>	Group A subgroups	Limits 3/		Unit
					Min	Max	
Propagation delay time, output enable, mDIR to mBn or mAn 3003	t <sub>PZH1</sub>	C <sub>L</sub> = 50 pF minimum R <sub>L</sub> = 500Ω See figure 7	5.0 V	9	1.5	6.3	ns
			4.5 V and 5.5 V	10, 11	1.5	7.5	
	t <sub>PZL1</sub>		5.0 V	9	1.5	6.5	
			4.5 V and 5.5 V	10, 11	1.5	7.8	
Propagation delay time, output enable, mOE to mBn or mAn 3003	t <sub>PZH2</sub>	C <sub>L</sub> = 50 pF minimum R <sub>L</sub> = 500Ω See figure 7	5.0 V	9	1.5	6.7	ns
			4.5 V and 5.5 V	10, 11	1.5	7.6	
	t <sub>PZL2</sub>		5.0 V	9	1.5	6.9	
			4.5 V and 5.5 V	10, 11	1.5	7.7	
Propagation delay time, output disable, mDIR to mBn or mAn 3003	t <sub>PHZ1</sub>	C <sub>L</sub> = 50 pF minimum R <sub>L</sub> = 500Ω See figure 7	5.0 V	9	2.0	8.8	ns
			4.5 V and 5.5 V	10, 11	2.0	10.3	
	t <sub>PLZ1</sub>		5.0 V	9	2.0	6.9	
			4.5 V and 5.5 V	10, 11	2.0	9.1	
Propagation delay time, output disable, mOE to mBn or mAn 3003	t <sub>PHZ2</sub>	C <sub>L</sub> = 50 pF minimum R <sub>L</sub> = 500Ω See figure 7	5.0 V	9	2.0	9.0	ns
			4.5 V and 5.5 V	10, 11	2.0	10.2	
	t <sub>PLZ2</sub>		5.0 V	9	2.0	7.1	
			4.5 V and 5.5 V	10, 11	2.0	9.4	
TEST MODE							
Clock frequency, TCK	f <sub>clock2</sub>	C <sub>L</sub> = 50 pF minimum R <sub>L</sub> = 500Ω See figure 7	4.5 V and 5.5 V	9, 10, 11	0.0	50.0	MHz
Pulse duration, TCK, high or low	t <sub>w2</sub>	C <sub>L</sub> = 50 pF minimum R <sub>L</sub> = 500Ω See figure 7	4.5 V and 5.5 V	9, 10, 11	8.0		ns

See footnotes at end of table.

STANDARD MICROCIRCUIT DRAWING DEFENSE ELECTRONICS SUPPLY CENTER DAYTON, OHIO 45444	SIZE <b>A</b>		<b>5962-96698</b>
		REVISION LEVEL	SHEET <b>9</b>

DESC FORM 193A  
JUL 94

9004708 0019494 006

TABLE 1. Electrical performance characteristics - Continued.

Test and MIL-STD-883 test method 1/	Symbol	Test conditions 2/ -55°C ≤ T <sub>C</sub> ≤ +125°C +4.5 V ≤ V <sub>CC</sub> ≤ +5.5 V unless otherwise specified	V <sub>CC</sub>	Group A subgroups	Limits 3/		Unit			
					Min	Max				
Setup time	t <sub>s2</sub>	C <sub>L</sub> = 50 pF minimum R <sub>L</sub> = 500Ω See figure 7	4.5 V and 5.5 V	9, 10, 11	6.0		ns			
								TDI before TCK↓	4.5	
								TMS before TCK↓	3.0	
Hold time	t <sub>h2</sub>	C <sub>L</sub> = 50 pF minimum R <sub>L</sub> = 500Ω See figure 7	4.5 V and 5.5 V	9, 10, 11	1.5		ns			
								TDI after TCK↓	1.0	
								TMS after TCK↓	1.5	
Maximum TCK frequency	f <sub>MAX2</sub>	C <sub>L</sub> = 50 pF minimum R <sub>L</sub> = 500Ω See figure 7	5.0 V	9	50		MHz			
			4.5 V and 5.5 V	10, 11	50					
Propagation delay time, TCK↓ to mAn or mBn 3003	t <sub>PLH4</sub>	C <sub>L</sub> = 50 pF minimum R <sub>L</sub> = 500Ω See figure 7	5.0 V	9	2.5	11.0	ns			
			4.5 V and 5.5 V	10, 11	2.5	13.1				
	t <sub>PHL4</sub>		5.0 V	9	2.5	10.8				
	4.5 V and 5.5 V		10, 11	2.5	12.6					
Propagation delay time, TCK↓ to TDO 3003	t <sub>PLH5</sub>	C <sub>L</sub> = 50 pF minimum R <sub>L</sub> = 500Ω See figure 7	5.0 V	9	2.0	5.1	ns			
			4.5 V and 5.5 V	10, 11	2.0	5.8				
	t <sub>PHL5</sub>		5.0 V	9	2.0	5.1				
	4.5 V and 5.5 V		10, 11	2.0	7.0					
Propagation delay time, output enable, TCK↓ to mAn or mBn 3003	t <sub>pZH3</sub>	C <sub>L</sub> = 50 pF minimum R <sub>L</sub> = 500Ω See figure 7	5.0 V	9	4.0	11.5	ns			
			4.5 V and 5.5 V	10, 11	4.0	13.9				
	t <sub>pZL3</sub>		5.0 V	9	4.0	11.8				
	4.5 V and 5.5 V		10, 11	4.0	14.2					

See footnotes at end of table.

STANDARD MICROCIRCUIT DRAWING DEFENSE ELECTRONICS SUPPLY CENTER DAYTON, OHIO 45444	SIZE <b>A</b>		5962-96698
		REVISION LEVEL	SHEET 10

TABLE I. Electrical performance characteristics - Continued.

Test and MIL-STD-883 test method <sup>1/</sup>	Symbol	Test conditions <sup>2/</sup> -55°C ≤ T <sub>C</sub> ≤ +125°C +4.5 V ≤ V <sub>CC</sub> ≤ +5.5 V unless otherwise specified	V <sub>CC</sub>	Group A subgroups	Limits <sup>3/</sup>		Unit
					Min	Max	
Propagation delay time, output enable, TCK↓ to TDO 3003	t <sub>PZH4</sub>	C <sub>L</sub> = 50 pF minimum R <sub>L</sub> = 500Ω See figure 7	5.0 V	9	2.0	5.7	ns
			4.5 V and 5.5 V	10, 11	2.0	6.6	
	5.0 V		9	2.0	6.2		
	4.5 V and 5.5 V		10, 11	2.0	6.9		
Propagation delay time, output disable, TCK↓ to mAn or mBn 3003	t <sub>PHZ3</sub>	C <sub>L</sub> = 50 pF minimum R <sub>L</sub> = 500Ω See figure 7	5.0 V	9	4.0	14.2	ns
			4.5 V and 5.5 V	10, 11	4.0	18.0	
	5.0 V		9	3.0	13.3		
	4.5 V and 5.5 V		10, 11	3.0	17.5		
Propagation delay time, output disable, TCK↓ to TDO 3003	t <sub>PHZ4</sub>	C <sub>L</sub> = 50 pF minimum R <sub>L</sub> = 500Ω See figure 7	5.0 V	9	3.0	6.8	ns
			4.5 V and 5.5 V	10, 11	3.0	7.4	
	5.0 V		9	2.5	5.5		
	4.5 V and 5.5 V		10, 11	2.5	6.4		

- 1/ For tests not listed in the referenced MIL-STD-883 (e.g. ΔI<sub>CC</sub>), utilize the general test procedure of 883 under the conditions listed herein.
- 2/ Each input/output, as applicable, shall be tested at the specified temperature, for the specified limits, to the tests in table I herein. Output terminals not designated shall be high level logic, low level logic, or open, except for all I<sub>CC</sub> and ΔI<sub>CC</sub> tests, where the output terminals shall be open. When performing these tests, the current meter shall be placed in the circuit such that all current flows through the meter. For input terminals not designated, V<sub>IN</sub> = GND or V<sub>IN</sub> ≥ 3.0 V.
- 3/ For negative and positive voltage and current values, the sign designates the potential difference in reference to GND and the direction of current flow, respectively, and the absolute value of the magnitude, not the sign, is relative to the minimum and maximum limits, as applicable, listed herein. All devices shall meet or exceed the limits specified in table I at 4.5 V ≤ V<sub>CC</sub> ≤ 5.5 V.
- 4/ For I/O ports, the limit includes I<sub>OZH</sub> or I<sub>OZL</sub> leakage current from the output circuitry.
- 5/ Not more than one output should be tested at one time, and the duration of the test condition should not exceed one second.
- 6/ This is the increase in supply current for each input that is at one of the specified TTL voltage levels rather than 0.0 V or V<sub>CC</sub>. This test may be performed either one input at a time (preferred method) or with all input pins simultaneously at V<sub>IN</sub> = V<sub>CC</sub> - 2.1 V (alternate method). When the test is performed using the alternate test method, the maximum limit is equal to the number of inputs at a high TTL input level times 1.5 mA, and the preferred method and limits are guaranteed.

<b>STANDARD MICROCIRCUIT DRAWING DEFENSE ELECTRONICS SUPPLY CENTER DAYTON, OHIO 45444</b>	<b>SIZE A</b>		<b>5962-96698</b>
		REVISION LEVEL	SHEET <b>11</b>

TABLE I. Electrical performance characteristics - Continued.

Z/ This test is for qualification only. Ground and  $V_{CC}$  bounce tests are performed on a non-switching (quiescent) output and are used to measure the magnitude of induced noise caused by other simultaneously switching outputs. The test is performed on a low noise bench test fixture. For the device under test, all outputs shall be loaded with 500 $\Omega$  of load resistance and a minimum of 50 pF of load capacitance (see figure 6). Only chip capacitors and resistors shall be used. The output load components shall be located as close as possible to the device outputs. It is suggested, that whenever possible, this distance be kept to less than 0.25 inches. Decoupling capacitors shall be placed in parallel from  $V_{CC}$  to ground. The values of these decoupling capacitors shall be determined by the device manufacturer. The low and high level ground and  $V_{CC}$  bounce noise is measured at the quiet output using a 1 GHz minimum bandwidth oscilloscope with a 50 $\Omega$  input impedance.

The device inputs shall be conditioned such that all outputs are at a high nominal  $V_{OH}$  level. The device inputs shall then be conditioned such that they switch simultaneously and the output under test remains at  $V_{OH}$  as all other outputs possible are switched from  $V_{OH}$  to  $V_{OL}$ .  $V_{OHV}$  and  $V_{OHP}$  are then measured from the nominal  $V_{OH}$  level to the largest negative and positive peaks, respectively (see figure 6). This is then repeated with the same outputs not under test switching from  $V_{OL}$  to  $V_{OH}$ .

The device inputs shall be conditioned such that all outputs are at a low nominal  $V_{OL}$  level. The device inputs shall then be conditioned such that they switch simultaneously and the output under test remains at  $V_{OL}$  as all other outputs possible are switched from  $V_{OL}$  to  $V_{OH}$ .  $V_{OLP}$  and  $V_{OLV}$  are then measured from the nominal  $V_{OL}$  level to the largest positive and negative peaks, respectively (see figure 6). This is then repeated with the same outputs not under test switching from  $V_{OH}$  to  $V_{OL}$ .

B/ Tests shall be performed in sequence, attributes data only. Functional tests shall include the truth table and other logic patterns used for fault detection. The test vectors used to verify the truth table shall, at a minimum, test all functions of each input and output. All possible input to output logic patterns per function shall be guaranteed, if not tested, to the truth table in figure 3 herein. Functional tests shall be performed in sequence as approved by the qualifying activity on qualified devices. After incorporating allowable tolerances per MIL-STD-883,  $V_{IL} = 0.4$  V and  $V_{IH} = 2.4$  V. For outputs,  $L \leq 0.8$  V,  $H \geq 2.0$  V.

STANDARD MICROCIRCUIT DRAWING DEFENSE ELECTRONICS SUPPLY CENTER DAYTON, OHIO 45444	SIZE <b>A</b>		5962-96698
		REVISION LEVEL	SHEET 12

查询"5962-9669801QXA"供应商

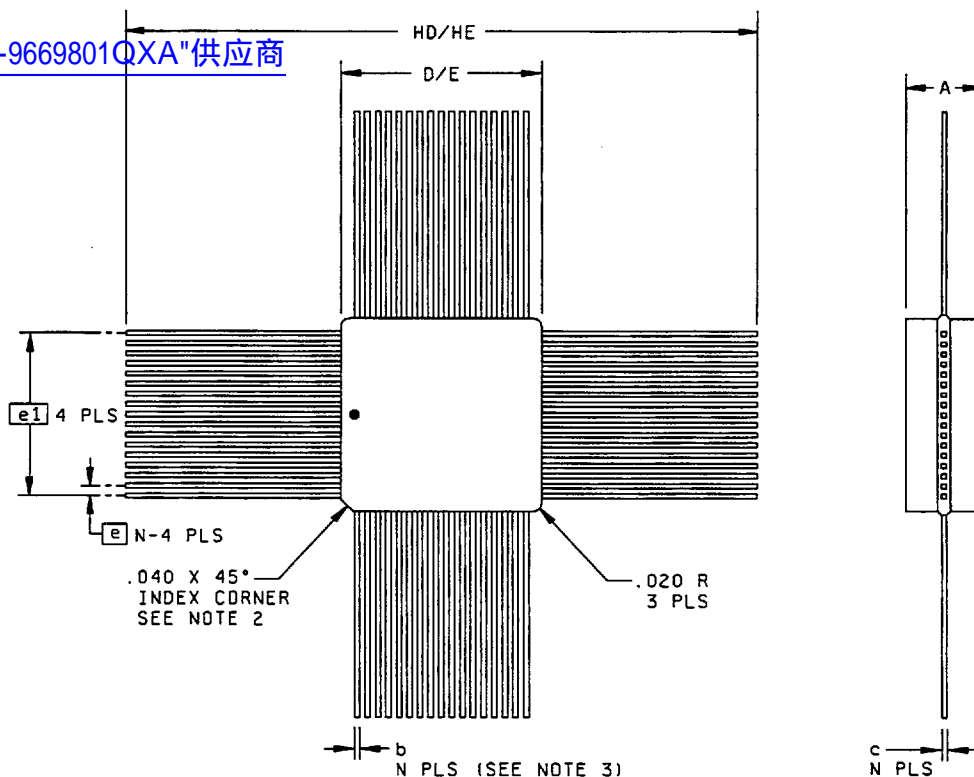

Dimension	Millimeters		Inches	
	Min	Max	Min	Max
HD/HE	33.02	38.10	1.300	1.500
D/E	12.32	12.70	.485	.500
A	3.404	3.912	.134	.154
b	0.203	0.330	.008	.013
e	0.635 BSC		.025 BSC	
e1	10.160 BSC		.400 BSC	
c	0.127	0.178	.005	.007
N	68		68	

NOTES:

1. The US government preferred system of measurement is the metric SI system. However, this item is originally designed using inch-pound units of measurement. In the event of conflict between the metric and inch-pound units, the inch-pound units shall take precedence.
2. A terminal 1 identification mark shall be located on the first side clockwise from the index corner. Terminal numbers shall increase in a counterclockwise direction when viewed as shown.
3. N is the maximum number of terminals.

FIGURE 1. Case outline.

<b>STANDARD MICROCIRCUIT DRAWING DEFENSE ELECTRONICS SUPPLY CENTER DAYTON, OHIO 45444</b>	<b>SIZE A</b>		<b>5962-96698</b>
		REVISION LEVEL	SHEET <b>13</b>

DESC FORM 193A  
JUL 94

9004708 0019498 751

Case outline		01	
Case outline		X	
Terminal number	Terminal symbol	Terminal number	Terminal symbol
1	NC	35	NC
2	V <sub>CC</sub>	36	V <sub>CC</sub>
3	TDO	37	TCK
4	1CLKAB	38	2CLKBA
5	1SAB	39	2SBA
6	GND	40	GND
7	1OE	41	2DIR
8	1A1	42	2B9
9	1A2	43	2B8
10	1A3	44	2B7
11	1A4	45	2B6
12	1A5	46	2B5
13	GND	47	GND
14	1A6	48	2B4
15	1A7	49	2B3
16	1A8	50	2B2
17	1A9	51	2B1
18	NC	52	NC
19	V <sub>CC</sub>	53	V <sub>CC</sub>
20	2A1	54	1B9
21	2A2	55	1B8
22	2A3	56	1B7
23	GND	57	GND
24	2A4	58	1B6
25	2A5	59	1B5
26	2A6	60	1B4
27	2A7	61	1B3
28	2A8	62	1B2
29	2A9	63	1B1
30	GND	64	GND
31	2OE	65	1DIR
32	2SAB	66	1SBA
33	2CLKAB	67	1CLKBA
34	TDI	68	TMS

FIGURE 2. Terminal connections.

STANDARD MICROCIRCUIT DRAWING DEFENSE ELECTRONICS SUPPLY CENTER DAYTON, OHIO 45444	SIZE <b>A</b>		5962-96698
		REVISION LEVEL	SHEET 14

查询"5962-9669801QXA"供应商

Terminal descriptions	
Terminal symbol	Description
mAn (m = 1 to 2, n = 1 to 9)	A-bus input/output ports
mBn (m = 1 to 2, n = 1 to 9)	B-bus input/output ports
mOE (m = 1 to 2)	Output enable control inputs
mSAB, mSBA (m = 1 to 2)	A-to-B/B-to-A select control inputs
mCLKAB, mCLKBA (m = 1 to 2)	A-to-B/B-to-A clock inputs
mDIR (m = 1 to 2)	Direction controls inputs
TDI	Test data input
TDO	Test data output
TMS	Test mode select input
TCK	Test clock input

FIGURE 2. Terminal connections - Continued.

Normal mode, each register

Inputs						Outputs		Operation or Function
mOE	mDIR	mCLKAB	mCLKBA	mSAB	mSBA	mA1 thru mA9	mB1 thru mB9	
X	X	↑	X	X	X	Input	Unspecified 1/	Store A, B unspecified 1/
X	X	X	↑	X	X	Unspecified 1/	Input	Store B, A unspecified 1/
H	X	↑	↑	X	X	Input	Input	Store A and B data
H	X	L	L	X	X	Input disabled	Input disabled	Isolation, hold storage
L	L	X	X	X	L	Output	Input	Real-time B data to A bus
L	L	X	X	X	H	Output	Input disabled	Stored B data to A bus
L	H	X	X	L	X	Input	Output	Real-time A data to B bus
L	H	X	X	H	X	Input disabled	Output	Stored A data to B bus

H = High voltage level  
 L = Low voltage level  
 X = Irrelevant  
 ↑ = Low-to-high clock transition.

1/ The data output functions can be enabled or disabled by various signals at the mOE and mDIR inputs. Data inputs are always enabled; i.e., data at the bus pins is stored on every low-to-high transition of the clock inputs.

FIGURE 3. Truth table.

<b>STANDARD          MICROCIRCUIT DRAWING          DEFENSE ELECTRONICS SUPPLY CENTER          DAYTON, OHIO 45444</b>	<b>SIZE          A</b>		<b>5962-96698</b>
		<b>REVISION LEVEL</b>	<b>SHEET          15</b>

DESC FORM 193A  
 JUL 94

9004708 0019500 13T

查询"5962-9669801QXA"供应商

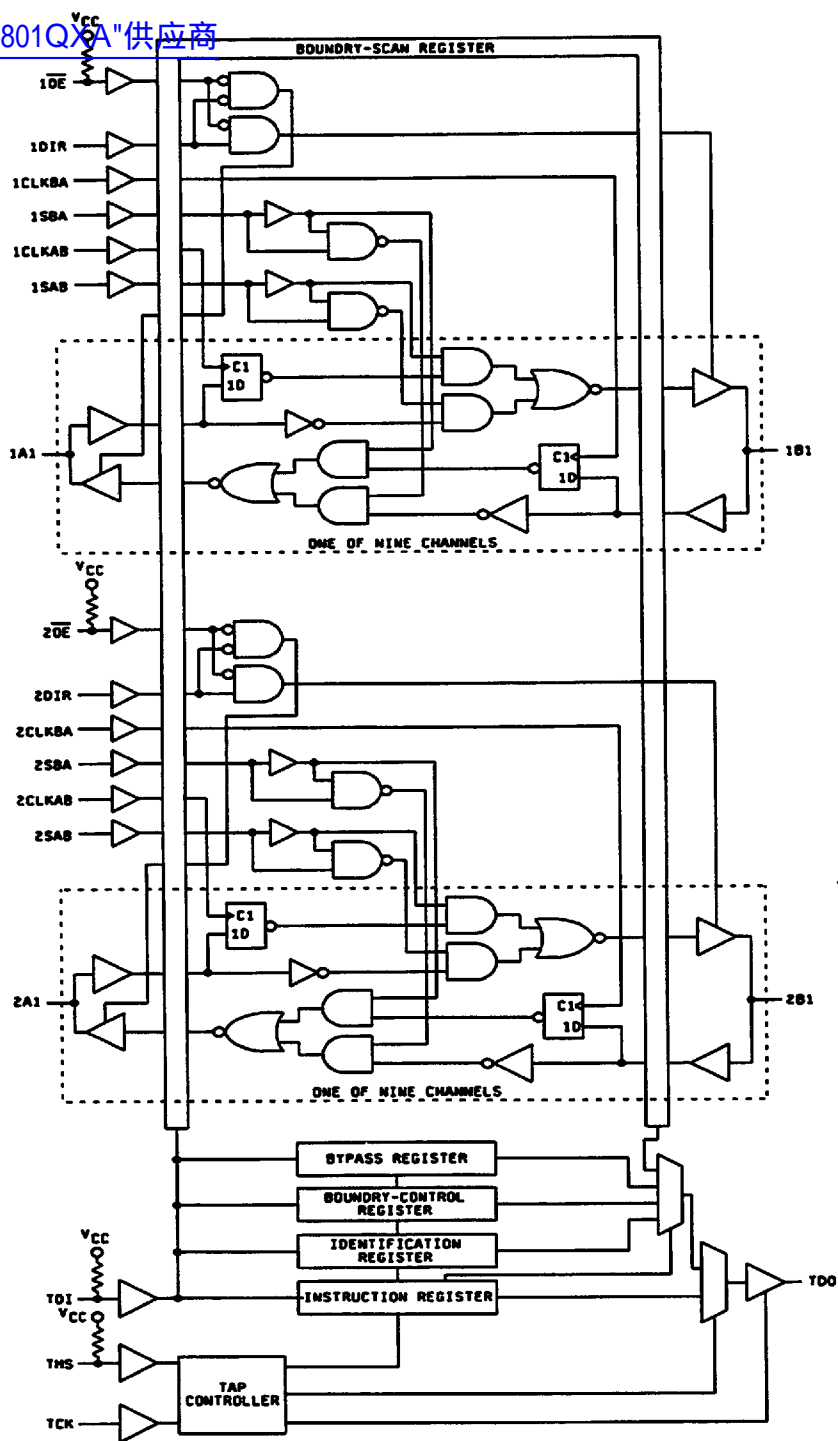

FIGURE 4. Block diagram.

STANDARD MICROCIRCUIT DRAWING DEFENSE ELECTRONICS SUPPLY CENTER DAYTON, OHIO 45444	SIZE <b>A</b>		5962-96698
		REVISION LEVEL	SHEET 16

DESC FORM 193A  
JUL 94

9004708 0019501 076



Test access port (TAP) controller state diagram

[查询"5962-9669801QXA"供应商](#)

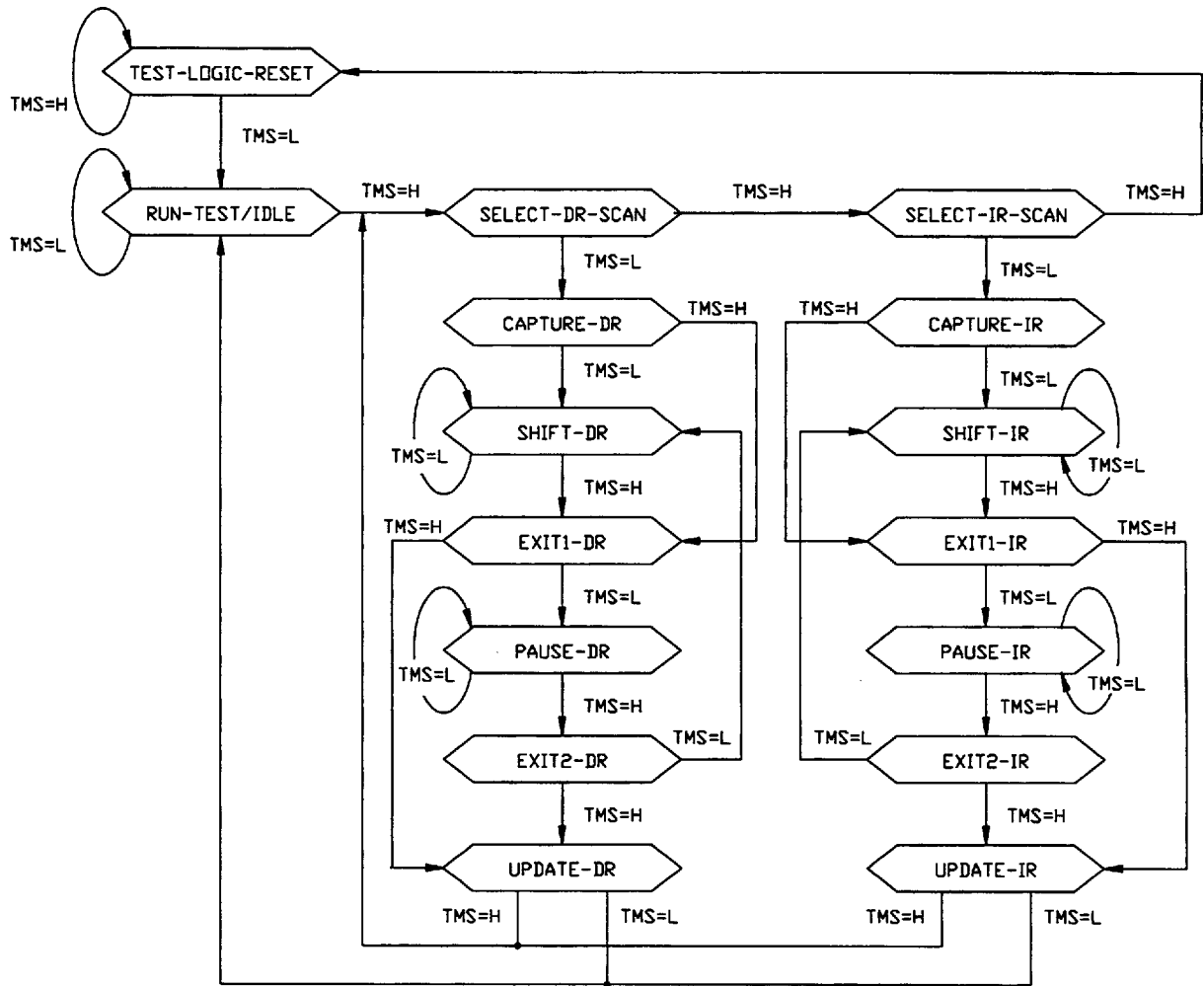

FIGURE 5. Test access port controller and scan test registers.

STANDARD  
MICROCIRCUIT DRAWING  
DEFENSE ELECTRONICS SUPPLY CENTER  
DAYTON, OHIO 45444

SIZE  
**A**

5962-96698

REVISION LEVEL

SHEET

17

Instruction register (IR) order of scan

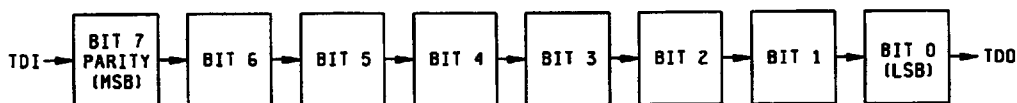

NOTE: During capture-IR, the IR captures the binary value 10000001. At power up or in the test-logic-reset state, the IR is reset to the binary value 10000001, which selects the IDCODE instruction.

Instruction-register opcodes

BINARY CODE <sup>1/</sup> BIT 7-BIT 0 MSB-LSB	SCOPE OPCODE	DESCRIPTION	SELECTED DATA REGISTER	MODE
00000000	EXTEST	Boundary scan	Boundary scan	Test
10000001	IDCODE	Identification read	Device identification	Normal
10000010	SAMPLE/PRELOAD	Sample boundary	Boundary scan	Normal
00000011	BYPASS <sup>2/</sup>	Bypass scan	Bypass	Normal
10000100	BYPASS <sup>2/</sup>	Bypass scan	Bypass	Normal
00000101	BYPASS <sup>2/</sup>	Bypass scan	Bypass	Normal
00000110	HIGHZ	Control boundary to high impedance	Bypass	Modified test
10000111	CLAMP	Control boundary to 1/0	Bypass	Test
10001000	BYPASS <sup>2/</sup>	Bypass scan	Bypass	Normal
00001001	RUNT	Boundary run test	Bypass	Test
00001010	READBN	Boundary read	Boundary scan	Normal
10001011	READBT	Boundary read	Boundary scan	Test
00001100	CELLTST	Boundary self test	Boundary scan	Normal
10001101	TOPHIP	Boundary toggle outputs	Bypass	Test
10001110	SCANCN	Boundary-control register scan	Boundary control	Normal
00001111	SCANCT	Boundary-control register scan	Boundary control	Test
All others	BYPASS	Bypass scan	Bypass	Normal

<sup>1/</sup> Bit 7 is used to maintain even parity in the 8-bit instruction.

<sup>2/</sup> The BYPASS instruction is executed in lieu of a SCOPE<sup>TM</sup> instruction that is not supported in this device.

FIGURE 5. Test access port controller and scan test registers - Continued.

<b>STANDARD MICROCIRCUIT DRAWING DEFENSE ELECTRONICS SUPPLY CENTER DAYTON, OHIO 45444</b>	<b>SIZE A</b>		<b>5962-96698</b>
		<b>REVISION LEVEL</b>	<b>SHEET 18</b>

Boundary-scan register (BSR) configuration

查询"5962-9669801 QXA"供应商

BSR bit number	Device signal	BSR bit number	Device signal	BSR bit number	Device signal
51	20EB	35	2A9-I/O	17	2B9-I/O
50	10EB	34	2A8-I/O	16	2B8-I/O
49	20EA	33	2A7-I/O	15	2B7-I/O
48	10EA	32	2A6-I/O	14	2B6-I/O
47	2DIR	31	2A5-I/O	13	2B5-I/O
46	1DIR	30	2A4-I/O	12	2B4-I/O
45	2OE	29	2A3-I/O	11	2B3-I/O
44	1OE	28	2A2-I/O	10	2B2-I/O
43	2CLKAB	27	2A1-I/O	9	2B1-I/O
42	1CLKAB	26	1A9-I/O	8	1B9-I/O
41	2CLKBA	25	1A8-I/O	7	1B8-I/O
40	1CLKBA	24	1A7-I/O	6	1B7-I/O
39	2SAB	23	1A6-I/O	5	1B6-I/O
38	1SAB	20	1A5-I/O	4	1B5-I/O
37	2SBA	21	1A4-I/O	3	1B4-I/O
36	1SBA	20	1A3-I/O	2	1B3-I/O
---	---	19	1A2-I/O	1	1B2-I/O
---	---	18	1A1-I/O	0	1B1-I/O

NOTE: The source data to be captured into the BSR during capture-DR is determined by the current instruction. The contents of the BSR can change during run-test/idle as determined by the current instruction. At power up or in test-logic-reset, BSCs 51 through 48 are reset to logic 0, ensuring that these cells, which control A-port and B-port outputs, are set to benign values (i.e., if test mode were invoked, the output would be at high-impedance state). Reset values of other BSCs should be considered indeterminate.

Boundary-control register order of scan



NOTE: During capture-DR (DR stands for data register) the contents of the BCR are not changed. At power up or in the test-logic-reset state, the BCR is reset to the binary value 010, which selects the PSA test operation.

FIGURE 5. Test access port controller and scan test registers - Continued.

<b>STANDARD MICROCIRCUIT DRAWING DEFENSE ELECTRONICS SUPPLY CENTER DAYTON, OHIO 45444</b>	<b>SIZE A</b>		<b>5962-96698</b>
		REVISION LEVEL	SHEET <b>19</b>

Boundary-control-register opcodes

查询"5962-9669801QXA"供应商

Binary code Bit 2-Bit 0 MSB-LSB	Description
X00	Sample inputs/toggle outputs (TOPSIP)
X01	Pseudo-random pattern generation/36-bit mode (PRPG)
X10	Parallel-signature analysis/36-bit mode (PSA)
011	Simultaneous PSA and PRPG/18-bit mode (PSA/PRPG)
111	Simultaneous PSA and binary count up/18-bit mode (PSA/COUNT)

Bypass register order of scan



NOTE: During capture-DR, the bypass register captures a logic 0.

Device identification register (IDR) configuration

IDR bit number	Identification significance	IDR bit number	Identification significance	IDR bit number	Identification significance <sup>1/</sup>
31	VERSION3	27	PARTNUMBER15	11	MANUFACTURER10
30	VERSION2	26	PARTNUMBER14	10	MANUFACTURER09
29	VERSION1	25	PARTNUMBER13	9	MANUFACTURER08
28	ERSION0	24	PARTNUMBER12	8	MANUFACTURER07
---	---	23	PARTNUMBER11	7	MANUFACTURER06
---	---	22	PARTNUMBER10	6	MANUFACTURER05
---	---	21	PARTNUMBER09	5	MANUFACTURER04
---	---	20	PARTNUMBER08	4	MANUFACTURER03
---	---	19	PARTNUMBER07	3	MANUFACTURER02
---	---	18	PARTNUMBER06	2	MANUFACTURER01
---	---	17	PARTNUMBER05	1	MANUFACTURER00
---	---	16	PARTNUMBER04	0	LOGIC1
---	---	15	PARTNUMBER03	---	---
---	---	14	PARTNUMBER02	---	---
---	---	13	PARTNUMBER01	---	---
---	---	12	PARTNUMBER00	---	---

<sup>1/</sup> For TI products, bits 11-0 of the device identification register always contain the binary value 000000101111 (02F, hex)

NOTE: During capture-DR, the binary value 00000000000000101001000000101111 (0002902F, hex) is captured in the device identification register to identify this device as Texas Instruments SNJ54ABTH18646A.

FIGURE 5. Test access port controller and scan test registers - Continued.

<b>STANDARD MICROCIRCUIT DRAWING DEFENSE ELECTRONICS SUPPLY CENTER DAYTON, OHIO 45444</b>	<b>SIZE A</b>		<b>5962-96698</b>
		REVISION LEVEL	SHEET 20

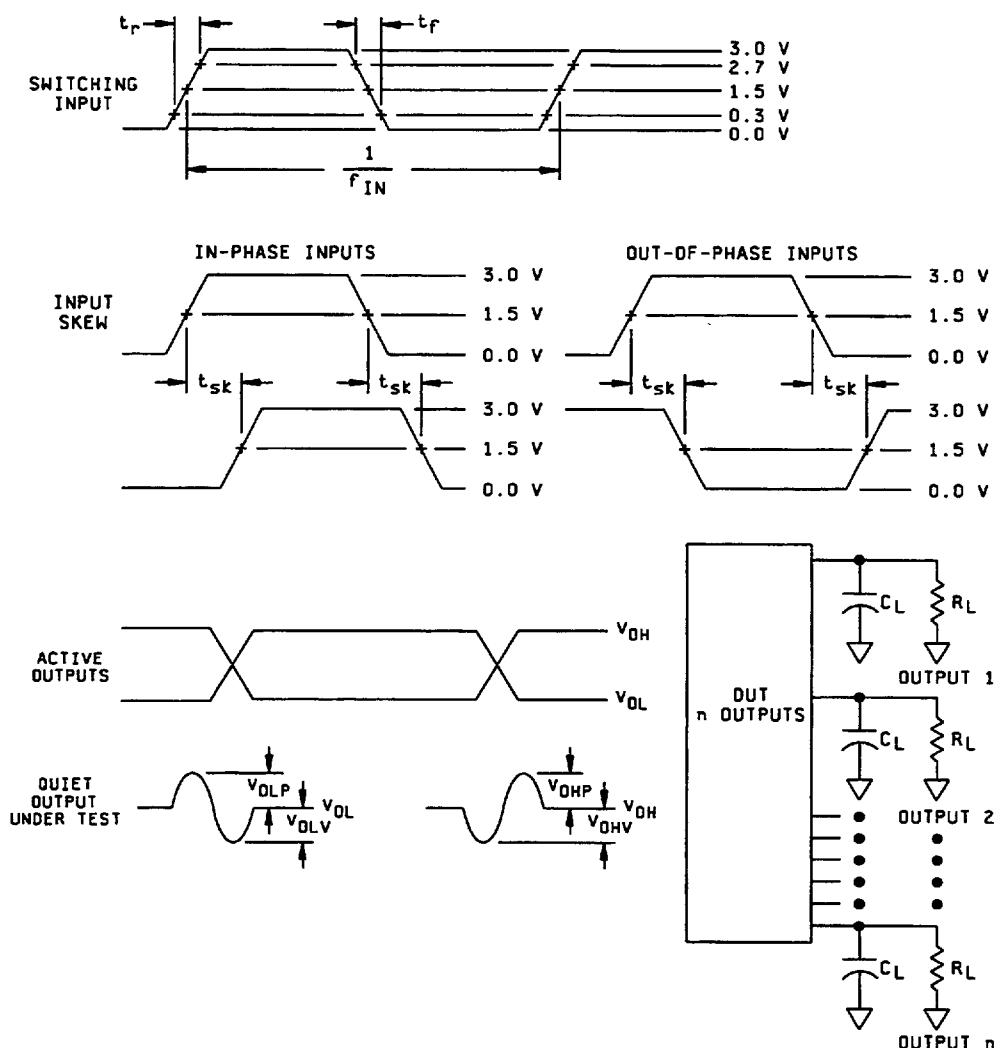

NOTES:

1.  $C_L$  includes a 47 pF chip capacitor (-0 percent, +20 percent) and at least 3 pF of equivalent capacitance from the test jig and probe.
2.  $R_L = 450\Omega \pm 1$  percent, chip resistor in series with a 50 $\Omega$  termination. For monitored outputs, the 50 $\Omega$  termination shall be the 50 $\Omega$  characteristic impedance of the coaxial connector to the oscilloscope.
3. Input signal to the device under test:
  - a.  $V_{IN} = 0.0$  V to 3.0 V; duty cycle = 50 percent;  $f_{IN} \geq 1$  MHz.
  - b.  $t_r, t_f = 3$  ns  $\pm 1.0$  ns. For input signal generators incapable of maintaining these values of  $t_r$  and  $t_f$ , the 3.0 ns limit may be increased up to 10 ns, as needed, maintaining the  $\pm 1.0$  ns tolerance and guaranteeing the results at 3.0 ns  $\pm 1.0$  ns; skew between any two switching inputs signals ( $t_{sk}$ ):  $\leq 250$  ps.

FIGURE 6. Ground bounce load circuit and waveforms.

STANDARD MICROCIRCUIT DRAWING DEFENSE ELECTRONICS SUPPLY CENTER DAYTON, OHIO 45444	SIZE <b>A</b>		5962-96698
		REVISION LEVEL	SHEET 21

[查询"5962-9669801QXA"供应商](#)

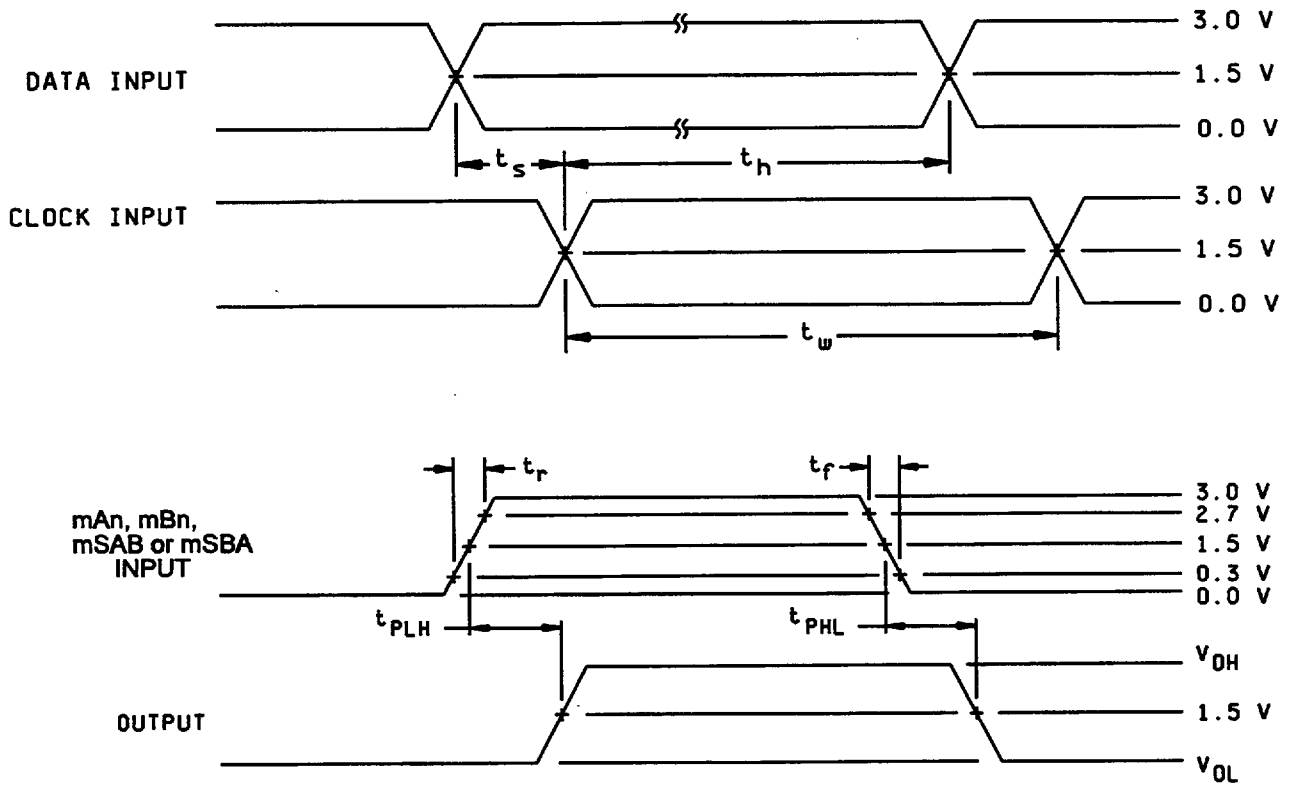

FIGURE 7. Switching waveforms and test circuit.

STANDARD  
MICROCIRCUIT DRAWING  
DEFENSE ELECTRONICS SUPPLY CENTER  
DAYTON, OHIO 45444

SIZE  
A

5962-96698

REVISION LEVEL

SHEET

22

DESC FORM 193A  
JUL 94

9004708 0019507 594

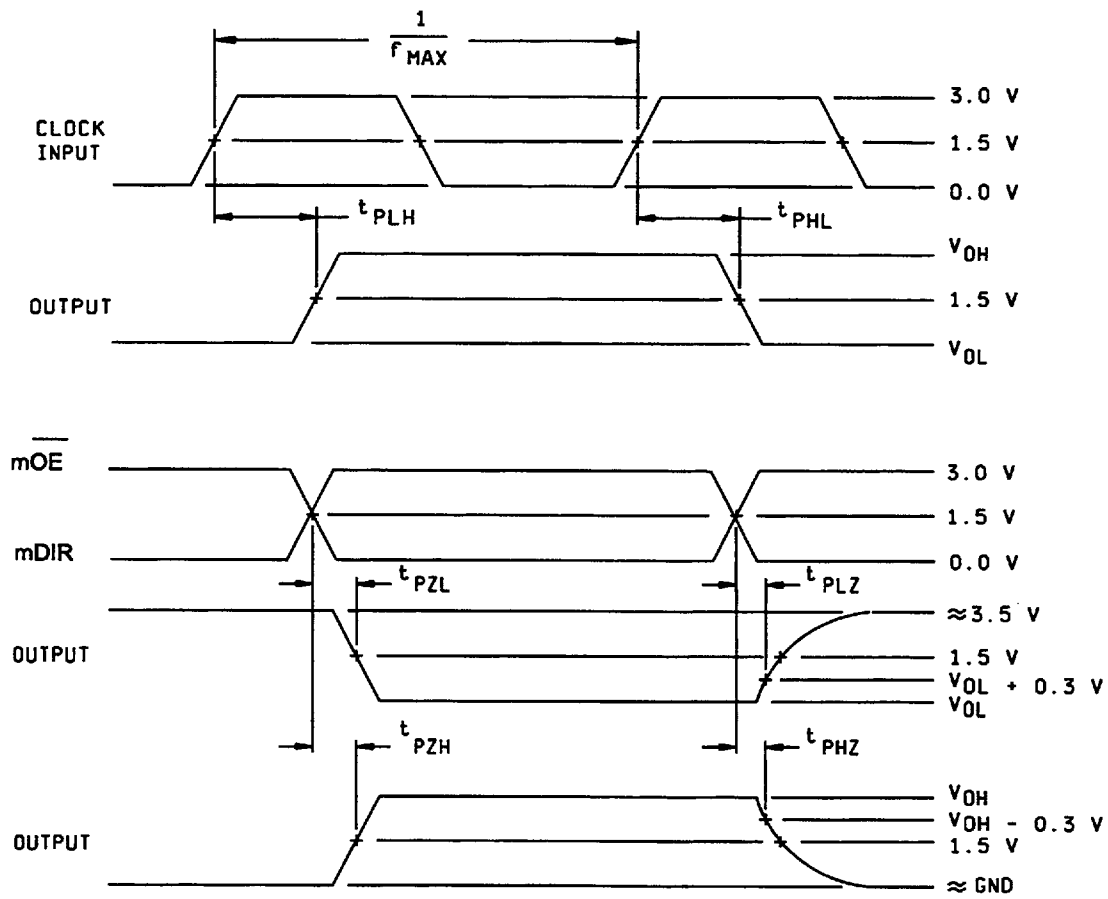

FIGURE 7. Switching waveforms and test circuit - Continued.

STANDARD  
MICROCIRCUIT DRAWING  
DEFENSE ELECTRONICS SUPPLY CENTER  
DAYTON, OHIO 45444

SIZE  
**A**

5962-96698

REVISION LEVEL

SHEET  
23

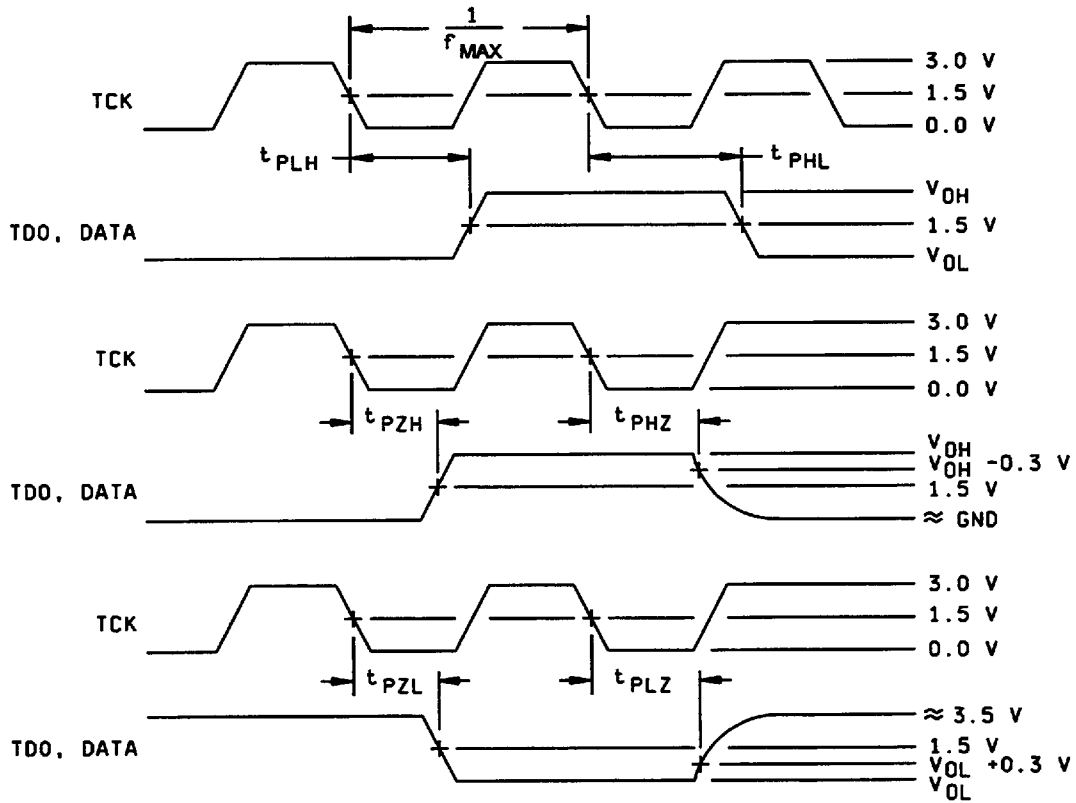

FIGURE 7. Switching waveforms and test circuit - Continued.

STANDARD  
MICROCIRCUIT DRAWING  
DEFENSE ELECTRONICS SUPPLY CENTER  
DAYTON, OHIO 45444

SIZE  
**A**

5962-96698

REVISION LEVEL

SHEET

24



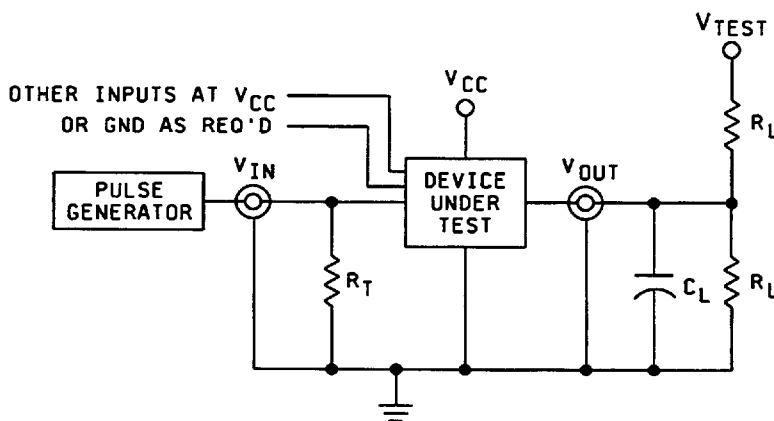
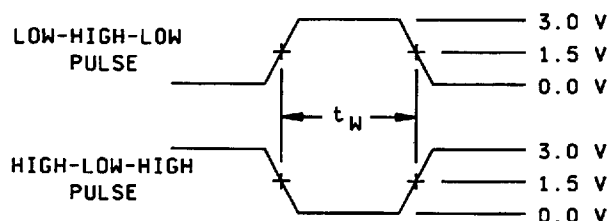
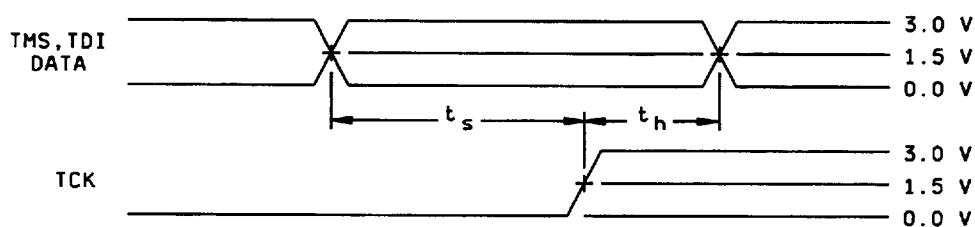

NOTES:

1. When measuring  $t_{PLZ}$  and  $t_{PZL}$ :  $V_{TEST} = 7.0$  V.
2. When measuring  $t_{PHZ}$ ,  $t_{PZH}$ ,  $t_{PLH}$ , and  $t_{PHL}$ :  $V_{TEST}$  = open.
3. The  $t_{PZL}$  and  $t_{PLZ}$  reference waveform is for the output under test with internal conditions such that the output is at  $V_{OL}$  except when disabled by the output enable control. The  $t_{PZH}$  and  $t_{PHZ}$  reference waveform is for the output under test with internal conditions such that the output is at  $V_{OH}$  except when disabled by the output enable control.
4.  $C_L$  = 50 pF minimum or equivalent (includes test jig and probe capacitance).
5.  $R_L$  = 500Ω or equivalent.
6.  $R_T$  = 50Ω or equivalent.
7. Input signal from pulse generator:  $V_{IN} = 0.0$  V to 3.0 V;  $PRR \leq 10$  MHz;  $t_r \leq 2.5$  ns;  $t_f \leq 2.5$  ns;  $t_r$  and  $t_f$  shall be measured from 0.3 V to 2.7 V and from 2.7 V to 0.3 V, respectively; duty cycle = 50 percent.
8. Timing parameters shall be tested at a minimum input frequency of 1 MHz.
9. The outputs are measured one at a time with one transition per measurement.

FIGURE 7. Switching waveforms and test circuit - Continued.

STANDARD MICROCIRCUIT DRAWING DEFENSE ELECTRONICS SUPPLY CENTER DAYTON, OHIO 45444	SIZE <b>A</b>		5962-96698
		REVISION LEVEL	SHEET 25

4.2 Screening. For device classes Q and V, screening shall be in accordance with MIL-PRF-38535, and shall be conducted on all devices prior to qualification and technology conformance inspection. For device class M, screening shall be in accordance with MIL-STD-883, and shall be conducted on all devices prior to quality conformance inspection.

4.2.1 Additional criteria for device class M.

a. Burn-in test, method 1015 of MIL-STD-883.

(1) Test condition A, B, C, or D. The test circuit shall be maintained by the manufacturer under document revision level control and shall be made available to the preparing or acquiring activity upon request. The test circuit shall specify the inputs, outputs, biases, and power dissipation, as applicable, in accordance with the intent specified in test method 1015 of MIL-STD-883.

(2)  $T_A = +125^\circ\text{C}$ , minimum.

b. Interim and final electrical test parameters shall be as specified in table II herein.

4.2.2 Additional criteria for device classes Q and V.

a. The burn-in test duration, test condition and test temperature, or approved alternatives shall be as specified in the device manufacturer's QM plan in accordance with MIL-PRF-38535. The burn-in test circuit shall be maintained under document revision level control of the device manufacturer's Technology Review Board (TRB) in accordance with MIL-PRF-38535 and shall be made available to the acquiring or preparing activity upon request. The test circuit shall specify the inputs, outputs, biases, and power dissipation, as applicable, in accordance with the intent specified in test method 1015 of MIL-STD-883.

b. Interim and final electrical test parameters shall be as specified in table II herein.

c. Additional screening for device class V beyond the requirements of device class Q shall be as specified in MIL-PRF-38535, appendix B.

4.3 Qualification inspection for device classes Q and V. Qualification inspection for device classes Q and V shall be in accordance with MIL-PRF-38535. Inspections to be performed shall be those specified in MIL-PRF-38535 and herein for groups A, B, C, D, and E inspections (see 4.4.1 through 4.4.4).

4.3.1 Electrostatic discharge sensitivity qualification inspection. Electrostatic discharge sensitivity (ESDS) testing shall be performed in accordance with MIL-STD-883, method 3015. ESDS testing shall be measured only for initial qualification and after process or design changes which may affect ESDS classification.

4.4 Conformance inspection. Technology conformance inspection for classes Q and V shall be in accordance with MIL-PRF-38535 including groups A, B, C, D, and E inspections and as specified herein except where option 2 of MIL-PRF-38535 permits alternate in-line control testing. Quality conformance inspection for device class M shall be in accordance with MIL-PRF-38535, appendix A and as specified herein. Inspections to be performed for device class M shall be those specified in method 5005 of MIL-STD-883 and herein for groups A, B, C, D, and E inspections (see 4.4.1 through 4.4.4).

4.4.1 Group A inspection.

a. Tests shall be as specified in table II herein.

b. For device class M, subgroups 7 and 8 tests shall be sufficient to verify the truth table in figure 3 herein. The test vectors used to verify the truth table shall, at a minimum, test all functions of each input and output. All possible input to output logic patterns per function shall be guaranteed, if not tested, to the truth table in figure 3, herein. For device classes Q and V, subgroups 7 and 8 shall include verifying the functionality of the device; these tests shall have been fault graded in accordance with MIL-STD-883, test method 5012 (see 1.5 herein).

c.  $C_{IN}$ ,  $C_{I/O}$ , and  $C_{OUT}$  shall be measured only for initial qualification and after process or design changes which may affect capacitance.  $C_{IN}$ ,  $C_{I/O}$ , and  $C_{OUT}$  shall be measured between the designated terminal and GND at a frequency of 1 MHz. This test may be performed at 10 MHz and guaranteed, if not tested, at 1 MHz. The DC bias for the pin under test ( $V_{BIAS}$ ) = 2.5 V or 3.0 V. For  $C_{IN}$ ,  $C_{I/O}$ , and  $C_{OUT}$ , test all applicable pins on five devices with zero failures.

For  $C_{IN}$ ,  $C_{I/O}$ , and  $C_{OUT}$ , a device manufacturer may qualify devices by functional groups. A specific functional group shall be composed of function types, that by design, will yield the same capacitance values when tested in accordance with table I, herein. The device manufacturer shall set a function group limit for the  $C_{IN}$ ,  $C_{I/O}$ , and  $C_{OUT}$  tests. The device manufacturer may then test one device functional group, to the limits and conditions specified herein. All other device functions in that particular functional group shall be guaranteed, if not tested, to the limits and test conditions specified in table I, herein. The device manufacturers shall submit to DESC-EC the device functions listed in each functional group and the test results for each device tested.

<b>STANDARD MICROCIRCUIT DRAWING DEFENSE ELECTRONICS SUPPLY CENTER DAYTON, OHIO 45444</b>	<b>SIZE A</b>		<b>5962-96698</b>
		<b>REVISION LEVEL</b>	<b>SHEET 26</b>

TABLE II. Electrical test requirements.

查询 5962-9669801QXA 供应商

Test requirements	Subgroups (in accordance with MIL-STD-883, method 5005, table I)	Subgroups (in accordance with MIL-PRF-38535, table III)	
	Device class M	Device class Q	Device class V
Interim electrical parameters (see 4.2)	- - -	- - -	1
Final electrical parameters (see 4.2)	1/ 1, 2, 3, 7, 8, 9, 10, 11	1/ 1, 2, 3, 7, 8, 9, 10, 11	2/ 1, 2, 3, 7, 8, 9, 10, 11
Group A test requirements (see 4.4)	1, 2, 3, 4, 7, 8, 9, 10, 11	1, 2, 3, 4, 7, 8, 9, 10, 11	1, 2, 3, 4, 7, 8, 9, 10, 11
Group C end-point electrical parameters (see 4.4)	1, 2, 3	1, 2, 3	1, 2, 3, 7, 8, 9, 10, 11
Group D end-point electrical parameters (see 4.4)	1, 2, 3	1, 2, 3	1, 2, 3
Group E end-point electrical parameters (see 4.4)	1, 7, 9	1, 7, 9	1, 7, 9

- 1/ PDA applies to subgroup 1.
- 2/ PDA applies to subgroups 1 and 7.

d. Ground and  $V_{CC}$  bounce tests are required for all device classes. These tests shall be performed only for initial qualification, after process or design changes which may affect the performance of the device, and any changes to the test fixture.  $V_{OLP}$ ,  $V_{OLV}$ ,  $V_{OHP}$ , and  $V_{OHV}$  shall be measured for the worst case outputs of the device. All other outputs shall be guaranteed, if not tested, to the limits established for the worst case outputs. The worst case outputs tested are to be determined by the manufacturer. Test 5 devices assembled in the worst case package type supplied to this document. All other package types shall be guaranteed, if not tested, to the limits established for the worst case package. The 5 devices to be tested shall be the worst case device type supplied to this drawing. All other device types shall be guaranteed, if not tested, to the limits established for the worst case device type. The package type and device type to be tested shall be determined by the manufacturer. The device manufacturer will submit to DESC-EC data that shall include all measured peak values for each device tested and detailed oscilloscope plots for each  $V_{OLP}$ ,  $V_{OLV}$ ,  $V_{OHP}$ , and  $V_{OHV}$  from one sample part per function. The plot shall contain the waveforms of both a switching output and the output under test.

Each device manufacturer shall test product on the fixtures they currently use. When a new fixture is used, the device manufacturer shall inform DESC-EC of this change and test the 5 devices on both the new and old test fixtures. The device manufacturer shall then submit to DESC-EC data from testing on both fixtures, that shall include all measured peak values for each device tested and detailed oscilloscope plots for each  $V_{OLP}$ ,  $V_{OLV}$ ,  $V_{OHP}$ , and  $V_{OHV}$  from one sample part per function. The plot shall contain the waveforms of both a switching output and the output under test.

For  $V_{OHP}$ ,  $V_{OHV}$ ,  $V_{OLP}$ , and  $V_{OLV}$ , a device manufacturer may qualify devices by functional groups. A specific functional group shall be composed of function types, that by design, will yield the same test values when tested in accordance with table I, herein. The device manufacturer shall set a functional group limit for the  $V_{OHP}$ ,  $V_{OHV}$ ,  $V_{OLP}$ , and  $V_{OLV}$  tests. The device manufacturer may then test one device function from a functional group, to the limits and conditions specified herein. All other device functions in that particular functional group shall be guaranteed, if not tested, to the limits and conditions specified in table I, herein. The device manufacturers shall submit to DESC-EC the device functions listed in each functional group and test results, along with the oscilloscope plots, for each device tested.

4.4.2 Group C inspection. The group C inspection end-point electrical parameters shall be as specified in table II herein.

<b>STANDARD MICROCIRCUIT DRAWING DEFENSE ELECTRONICS SUPPLY CENTER DAYTON, OHIO 45444</b>	<b>SIZE A</b>		<b>5962-96698</b>
		REVISION LEVEL	SHEET <b>27</b>

4.4.2.1 Additional criteria for device class M. Steady-state life test conditions, method 1005 of MIL-STD-883:

- 查海"5962-9669804 QXA" 供应商
- a. The test circuit shall be maintained by the manufacturer under document revision level control and shall be made available to the preparing or acquiring activity upon request. The test circuit shall specify the inputs, outputs, biases, and power dissipation, as applicable, in accordance with the intent specified in test method 1005 of MIL-STD-883.
  - b.  $T_A = +125^{\circ}\text{C}$ , minimum.
  - c. Test duration: 1,000 hours, except as permitted by method 1005 of MIL-STD-883.

4.4.2.2 Additional criteria for device classes Q and V. The steady-state life test duration, test condition and test temperature, or approved alternatives shall be as specified in the device manufacturer's QM plan in accordance with MIL-PRF-38535. The test circuit shall be maintained under document revision level control by the device manufacturer's TRB in accordance with MIL-PRF-38535 and shall be made available to the acquiring or preparing activity upon request. The test circuit shall specify the inputs, outputs, biases, and power dissipation, as applicable, in accordance with the intent specified in test method 1005 of MIL-STD-883.

4.4.3 Group D inspection. The group D inspection end-point electrical parameters shall be as specified in table II herein.

4.4.4 Group E inspection. Group E inspection is required only for parts intended to be marked as radiation hardness assured (see 3.5 herein).

- a. End-point electrical parameters shall be as specified in table II herein.
- b. For device classes Q and V, the devices or test vehicle shall be subjected to radiation hardness assured tests as specified in MIL-PRF-38535 for the RHA level being tested. For device class M, the devices shall be subjected to radiation hardness assured tests as specified in MIL-PRF-38535, appendix A for the RHA level being tested. All device classes must meet the postirradiation end-point electrical parameter limits as defined in table I at  $T_A = +25^{\circ}\text{C} \pm 5^{\circ}\text{C}$ , after exposure, to the subgroups specified in table II herein.
- c. When specified in the purchase order or contract, a copy of the RHA delta limits shall be supplied.

4.5 Methods of inspection. Methods of inspection shall be specified as follows:

4.5.1 Voltage and current. Unless otherwise specified, all voltages given are referenced to the microcircuit GND terminal. Currents given are conventional current and positive when flowing into the referenced terminal.

## 5. PACKAGING

5.1 Packaging requirements. The requirements for packaging shall be in accordance with MIL-PRF-38535 for device classes Q and V or MIL-PRF-38535, appendix A for device class M.

## 6. NOTES

6.1 Intended use. Microcircuits conforming to this drawing are intended for use for Government microcircuit applications (original equipment), design applications, and logistics purposes.

6.1.1 Replaceability. Microcircuits covered by this drawing will replace the same generic device covered by a contractor-prepared specification or drawing.

6.1.2 Substitutability. Device class Q devices will replace device class M devices.

6.2 Configuration control of SMD's. All proposed changes to existing SMD's will be coordinated with the users of record for the individual documents. This coordination will be accomplished in accordance with MIL-STD-973 using DD Form 1692, Engineering Change Proposal.

6.3 Record of users. Military and industrial users should inform Defense Electronics Supply Center when a system application requires configuration control and which SMD's are applicable to that system. DESC will maintain a record of users and this list will be used for coordination and distribution of changes to the drawings. Users of drawings covering microelectronic devices (FSC 5962) should contact DESC-EC, telephone (513) 296-6047.

6.4 Comments. Comments on this drawing should be directed to DESC-EC, Dayton, Ohio 45444-5270, or telephone (513) 296-5377.

6.5 Abbreviations, symbols, and definitions. The abbreviations, symbols, and definitions used herein are defined in MIL-PRF-38535 and MIL-HDBK-1331.

6.6 Sources of supply.

6.6.1 Sources of supply for device classes Q and V. Sources of supply for device classes Q and V are listed in QML-38535. The vendors listed in QML-38535 have submitted a certificate of compliance (see 3.6 herein) to DESC-EC and have agreed to this drawing.

6.6.2 Approved sources of supply for device class M. Approved sources of supply for class M are listed in MIL-HDBK-103. The vendors listed in MIL-HDBK-103 have agreed to this drawing and a certificate of compliance (see 3.6 herein) has been submitted to and accepted by DESC-EC.

STANDARD MICROCIRCUIT DRAWING DEFENSE ELECTRONICS SUPPLY CENTER DAYTON, OHIO 45444	SIZE A		5962-96698
		REVISION LEVEL	SHEET 28