

**Standard Avalanche SMD Rectifier**



**DO-214AC (SMA)**

**FEATURES**

- Low profile package
- Ideal for automated placement
- Controlled avalanche characteristics
- Glass passivated junction
- Low reverse current
- High surge current capability
- Meets MSL level 1, per J-STD-020, LF maximum peak of 260 °C
- Solder dip 260 °C, 40 s
- Compliant to RoHS directive 2002/95/EC and in accordance to WEEE 2002/96/EC



**RoHS**  
COMPLIANT

**PRIMARY CHARACTERISTICS**

$I_{F(AV)}$	1.5 A
$V_{RRM}$	200 V to 1600 V
$I_{FSM}$	30 A
$I_R$	1.0 $\mu$ A
$V_F$	1.15 V
$E_R$	20 mJ
$T_J$ max.	150 °C

**TYPICAL APPLICATIONS**

For use in general purpose rectification of power supplies, inverters, converters and freewheeling diodes for consumer, automotive and telecommunication.

**MECHANICAL DATA**

**Case:** DO-214AC (SMA)

Epoxy meets UL 94 V-0 flammability rating

**Terminals:** Matte tin plated leads, solderable per J-STD-002 and JESD 22-B102

E3 suffix for consumer grade, meets JESD 201 class 1A whisker test, HE3 suffix for high reliability grade (AEC-Q101 qualified), meets JESD 201 class 2 whisker test

**Note:**

- BYG10Y for commercial grade only

**Polarity:** Color band denotes the cathode end

**MAXIMUM RATINGS** ( $T_A = 25$  °C unless otherwise noted)

PARAMETER	SYMBOL	BYG10D	BYG10G	BYG10J	BYG10K	BYG10M	BYG10Y	UNIT
Device marking code		BYG10D	BYG10G	BYG10J	BYG10K	BYG10M	BYG10Y	
Maximum repetitive peak reverse voltage	$V_{RRM}$	200	400	600	800	1000	1600	V
Average forward current	$I_{F(AV)}$	1.5						A
Peak forward surge current 10 ms single half sine-wave superimposed on rated load	$I_{FSM}$	30						A
Pulse energy in avalanche mode, non repetitive (inductive load switch off) $I_{(BR)R} = 1$ A, $T_J = 25$ °C (for BYG10D-BYG10M)	$E_R$	20						mJ
Operating junction and storage temperature range	$T_J, T_{STG}$	- 55 to + 150						°C



# BYG10D thru BYG10Y

Vishay General Semiconductor



ELECTRICAL CHARACTERISTICS (T <sub>A</sub> = 25 °C unless otherwise noted)										
PARAMETER	TEST CONDITIONS		SYMBOL	BYG10D	BYG10G	BYG10J	BYG10K	BYG10M	BYG10Y	UNIT
Maximum instantaneous forward voltage (1)	I <sub>F</sub> = 1 A I <sub>F</sub> = 1.5 A	T <sub>J</sub> = 25 °C	V <sub>F</sub>				1.1 1.15			V
Maximum DC reverse current	V <sub>R</sub> = V <sub>RRM</sub>	T <sub>J</sub> = 25 °C T <sub>J</sub> = 100 °C	I <sub>R</sub>				1 10			μA
Maximum reverse recovery time	I <sub>F</sub> = 0.5 A, I <sub>R</sub> = 1.0 A, I <sub>rr</sub> = 0.25 A		t <sub>rr</sub>				4			μs

**Note:**

(1) Pulse test: 300 μs pulse width, 1 % duty cycle

THERMAL CHARACTERISTICS (T <sub>A</sub> = 25 °C unless otherwise noted)									
PARAMETER	SYMBOL	BYG10D	BYG10G	BYG10J	BYG10K	BYG10M	BYG10Y	UNIT	
Typical thermal resistance, junction to lead	R <sub>θJL</sub>	25						°C/W	
Typical thermal resistance, junction to ambient	R <sub>θJA</sub>	150 (1) 125 (2) 100 (3)						°C/W	

**Notes:**

- (1) Mounted on epoxy-glass hard tissue
- (2) Mounted on epoxy-glass hard tissue, 50 mm<sup>2</sup> 35 μm Cu
- (3) Mounted on Al-oxide-ceramic (Al<sub>2</sub>O<sub>3</sub>), 50 mm<sup>2</sup> 35 μm Cu

ORDERING INFORMATION (Example)				
PREFERRED P/N	UNIT WEIGHT (g)	PACKAGE CODE	BASE QUANTITY	DELIVERY MODE
BYG10D-E3/TR	0.064	TR	1800	7" diameter plastic tape and reel
BYG10D-E3/TR3	0.064	TR3	7500	13" diameter plastic tape and reel
BYG10DHE3/TR (1)	0.064	TR	1800	7" diameter plastic tape and reel
BYG10DHE3/TR3 (1)	0.064	TR3	7500	13" diameter plastic tape and reel

**Note:**

(1) AEC-Q101 qualified

**RATINGS AND CHARACTERISTICS CURVES**

( $T_A = 25\text{ }^\circ\text{C}$  unless otherwise noted)

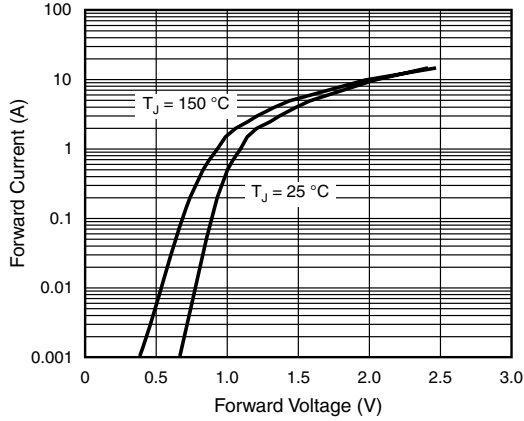

Figure 1. Forward Current vs. Forward Voltage

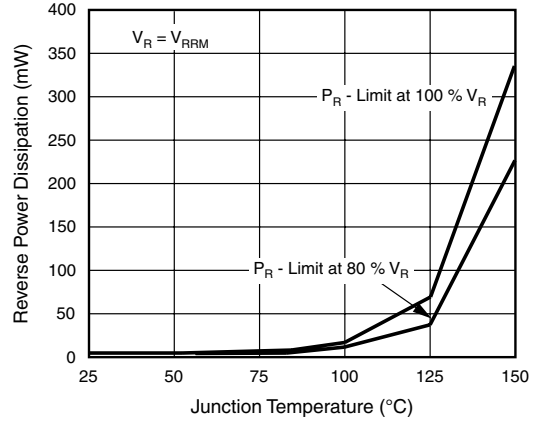

Figure 4. Max. Reverse Power Dissipation vs. Junction Temperature

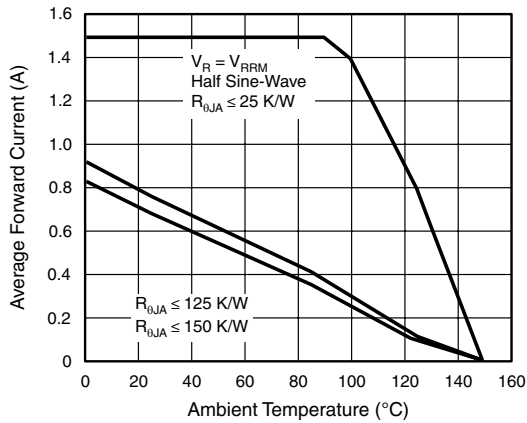

Figure 2. Max. Average Forward Current vs. Ambient Temperature

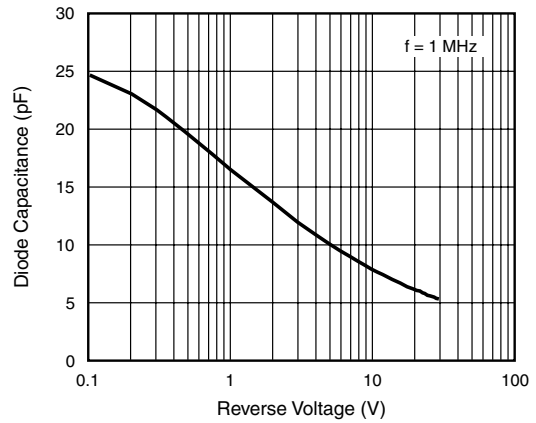

Figure 5. Diode Capacitance vs. Reverse Voltage

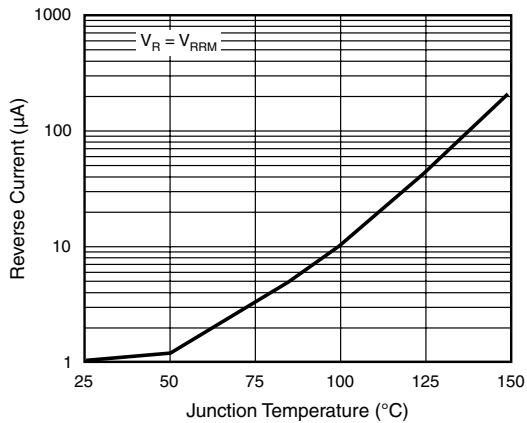

Figure 3. Reverse Current vs. Junction Temperature

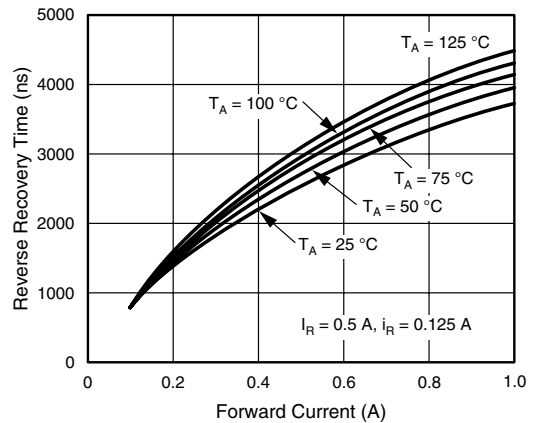

Figure 6. Reverse Recovery Time vs. Forward Current

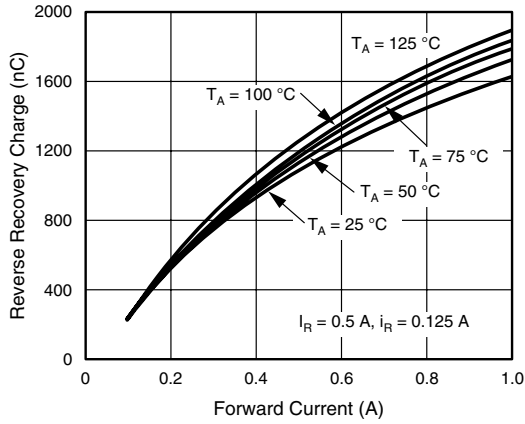
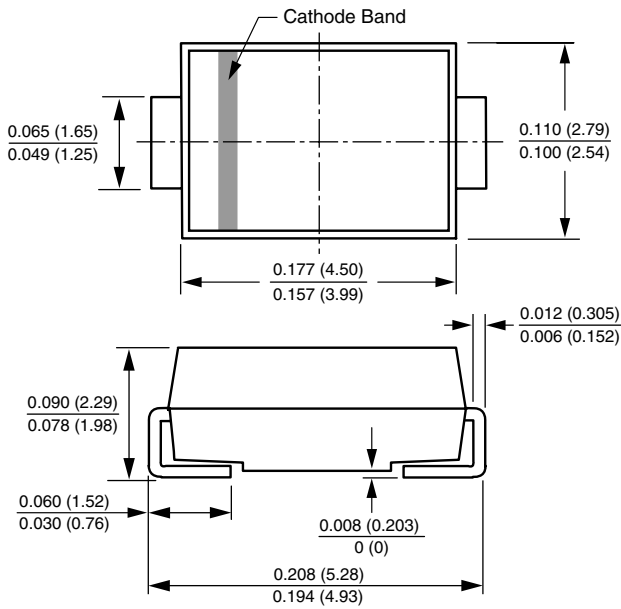

Figure 7. Reverse Recovery Charge vs. Forward Current

## PACKAGE OUTLINE DIMENSIONS in inches (millimeters)

### DO-214AC (SMA)



### Mounting Pad Layout

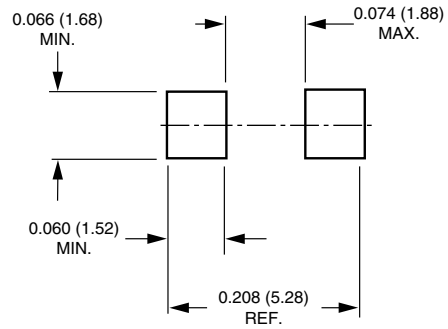

## **Disclaimer**

All product specifications and data are subject to change without notice.

Vishay Intertechnology, Inc., its affiliates, agents, and employees, and all persons acting on its or their behalf (collectively, "Vishay"), disclaim any and all liability for any errors, inaccuracies or incompleteness contained herein or in any other disclosure relating to any product.

Vishay disclaims any and all liability arising out of the use or application of any product described herein or of any information provided herein to the maximum extent permitted by law. The product specifications do not expand or otherwise modify Vishay's terms and conditions of purchase, including but not limited to the warranty expressed therein, which apply to these products.

No license, express or implied, by estoppel or otherwise, to any intellectual property rights is granted by this document or by any conduct of Vishay.

The products shown herein are not designed for use in medical, life-saving, or life-sustaining applications unless otherwise expressly indicated. Customers using or selling Vishay products not expressly indicated for use in such applications do so entirely at their own risk and agree to fully indemnify Vishay for any damages arising or resulting from such use or sale. Please contact authorized Vishay personnel to obtain written terms and conditions regarding products designed for such applications.

Product names and markings noted herein may be trademarks of their respective owners.