

LB11620T — Monolithic Digital IC Brushless Motor Driver

Overview

The LB11620T is a direct PWM drive predriver IC that is optimal for three-phase power brushless motors. A motor driver circuit with the desired output capability (voltage and current) can be implemented by adding discrete transistors or other power devices to the outputs of this IC. Since the LB11620T is provided in a miniature package, it is also appropriate for use with miniature motors as well.

Features

- Three-phase bipolar drive
- Direct PWM drive (input of either a control voltage or a variable-duty PWM signal)
- Built-in forward/reverse switching circuit
- Full complement of protection circuits (current limiter, low-voltage, and automatic recovery lock (motor constraint) protection circuits)
- Selectable Hall sensor signal pulse output

Specifications

Maximum Ratings at $T_a = 25^\circ\text{C}$

Parameter	Symbol	Conditions	Ratings	Unit
Supply voltage 1	$V_{CC\ max}$	$V_{CC\ pin}$	18	V
Output current	$I_O\ max$	UL, VL, WL, UH, VH, WH pins	30	mA
Allowable power dissipation	$P_d\ max$	*Mounted on a circuit board.	0.8	W
Operating temperature	T_{opr}		-20 to +100	$^\circ\text{C}$
Storage temperature	T_{stg}		-55 to +150	$^\circ\text{C}$

* Mounted on a circuit board : 114.3mm×76.1mm×1.6mm, glass epoxy board.

■ Any and all SANYO Semiconductor Co.,Ltd. products described or contained herein are, with regard to "standard application", intended for the use as general electronics equipment (home appliances, AV equipment, communication device, office equipment, industrial equipment etc.). The products mentioned herein shall not be intended for use for any "special application" (medical equipment whose purpose is to sustain life, aerospace instrument, nuclear control device, burning appliances, transportation machine, traffic signal system, safety equipment etc.) that shall require extremely high level of reliability and can directly threaten human lives in case of failure or malfunction of the product or may cause harm to human bodies, nor shall they grant any guarantee thereof. If you should intend to use our products for applications outside the standard applications of our customer who is considering such use and/or outside the scope of our intended standard applications, please consult with us prior to the intended use. If there is no consultation or inquiry before the intended use, our customer shall be solely responsible for the use.

■ Specifications of any and all SANYO Semiconductor Co.,Ltd. products described or contained herein stipulate the performance, characteristics, and functions of the described products in the independent state, and are not guarantees of the performance, characteristics, and functions of the described products as mounted in the customer's products or equipment. To verify symptoms and states that cannot be evaluated in an independent device, the customer should always evaluate and test devices mounted in the customer's products or equipment.

LB11620T

Recommended Operating Ranges at $T_a = 25^\circ\text{C}$

Parameter	Symbol	Conditions	Ratings	Unit
Supply voltage range 1-1	V_{CC1-1}	V_{CC} pin	8 to 17	V
Supply voltage range 1-2	V_{CC1-2}	V_{CC} pin, with V_{CC} shorted to VREG	4.5 to 5.5	V
Output current	I_O	UL, VL, WL, UH, VH, WH pins	25	mA
5 V constant voltage output current	IREG		-30	mA
HP pin voltage	VHP		0 to 17	V
HP pin output current	IHP		0 to 15	mA
RD pin voltage	VRD		0 to 17	V
RD pin output current	IRD		0 to 15	mA

Electrical Characteristics at $T_a = 25^\circ\text{C}$, $V_{CC} = 12\text{V}$

Parameter	Symbol	Conditions	Ratings			Unit
			min	typ	max	
Supply voltage 1	I_{CC1}			12	16	mA
5V constant voltage output (VREG pin)						
Output voltage	VREG		4.7	5.0	5.3	V
Line regulation	ΔV_{REG1}	$V_{CC} = 8$ to 17V		40	100	mV
Load regulation	ΔV_{REG2}	$I_O = -5$ to -20mA		10	30	mV
Temperature coefficient	ΔV_{REG3}	Design target		0		mV/ $^\circ\text{C}$
Low-voltage protection circuit (VREG pin)						
Operating voltage	VSDL		3.5	3.7	3.9	V
Clear voltage	VSDH		3.95	4.15	4.35	V
Hysteresis	ΔV_{SD}		0.3	0.45	0.6	V
Output Block						
Output voltage 1-1	V_{OUT1-1}	Low level $I_O = 400\mu\text{A}$		0.2	0.5	V
Output voltage 1-2	V_{OUT1-2}	Low level $I_O = 10\text{mA}$		0.9	1.2	V
Output voltage 2	V_{OUT2}	High level $I_O = -20\text{mA}$	$V_{CC-1.1}$	$V_{CC-0.9}$		V
Output leakage current	I_{Oleak}				10	μA
Hall Amplifier Block						
Input bias current	IHB (HA)		-2	-0.5		μA
Common-mode input voltage range 1	VICM1	When a Hall effect sensor is used	0.5		$V_{CC-2.0}$	V
Common-mode input voltage range 2	VICM2	For single-sided input bias (Hall IC application)	0		V_{CC}	V
Hall input sensitivity			80			mVp-p
Hysteresis	ΔV_{IN} (HA)		15	24	40	mV
Input voltage low \rightarrow high	VSLH (HA)		5	12	20	mV
Input voltage high \rightarrow low	VSHL (HA)		-20	-12	-5	mV
PWM Oscillator (PWM pin)						
High-level output voltage	V_{OH} (PWM)		2.75	3.0	3.25	V
Low-level output voltage	V_{OL} (PWM)		1.2	1.35	1.5	V
External capacitor charge current	ICHG	$V_{PWM} = 2.1\text{V}$	-120	-90	-65	μA
Oscillator frequency	f (PWM)	$C = 2000\text{pF}$		22		kHz
Amplitude	V (PWM)		1.4	1.6	1.9	Vp-p

Continued on next page

LB11620T

Continued from preceding page.

Parameter	Symbol	Conditions	Ratings			Unit
			min	typ	max	
EI+ pin						
Input bias current	IB (CTL)		-1		1	μA
Common-mode input voltage range	VICM		0		VREG-1.7	V
Input voltage 1	VCTL1	Output duty 100%		3.0		V
Input voltage 2	VCTL2	Output duty 0%		1.35		V
Input voltage 1L	VCTL1L	Design target value. When VREG = 4.7V, 100%		2.82		V
Input voltage 2L	VCTL2L	Design target value. When VREG = 4.7V, 0%		1.29		V
Input voltage 1H	VCTL1H	Design target value. When VREG = 5.3V, 100%		3.18		V
Input voltage 2H	VCTL2H	Design target value. When VREG = 5.3V, 0%		1.44		V
HP pin						
Output saturation voltage	VHPL	I _O = 10mA		0.2	0.5	V
Output leakage current	IHPLeak	V _O = 18V			10	μA
CSD oscillator (CSD pin)						
High-level output voltage	V _{OH} (CSD)		2.7	3.0	3.3	V
Low-level output voltage	V _{OL} (CSD)		0.7	1.0	1.3	V
External capacitor charge current	ICHG1	VCSD = 2V	-3.15	-2.5	-1.85	μA
External capacitor discharge current	ICHG2	VCSD = 2V	0.1	0.14	0.18	μA
Charge/discharge current ratio	RCSD	Charge current /discharge current	15	18	21	Times
RD pin						
Low-level output voltage	VRDL	I _O = 10mA		0.2	0.5	V
Output leakage current	IL (RD)	V _O = 18V			10	μA
Current limiter circuit (RF pin)						
Limiter voltage	VRF	RF-GND	0.225	0.25	0.275	V
PWMIN pin						
Input frequency	f (PI)				50	kHz
High-level input voltage	V _{IH} (PI)		2.0		VREG	V
Low-level input voltage	V _{IL} (PI)		0		1.0	V
Input open voltage	V _{IO} (PI)		VREG-0.5		VREG	V
Hysteresis	V _{IS} (PI)		0.2	0.25	0.4	V
High-level input current	I _{IH} (PI)	VPWMIN = VREG	-10	0	10	μA
Low-level input current	I _{IL} (PI)	VPWMIN = 0V	-130	-90		μA
F/R pin						
High-level input voltage	V _{IH} (FR)		2.0		VREG	V
Low-level input voltage	V _{IL} (FR)		0		1.0	V
Input open voltage	V _{IO} (FR)		VREG-0.5		VREG	V
Hysteresis	V _{IS} (FR)		0.2	0.25	0.4	V
High-level input current	I _{IH} (FR)		-10	0	10	μA
Low-level input current	I _{IL} (FR)		-130	-90		μA
N1 pin						
High-level input voltage	V _{IH} (N1)		2.0		VREG	V
Low-level input voltage	V _{IL} (N1)		0		1.0	V
Input open voltage	V _{IO} (N1)		VREG-0.5		VREG	V
High-level input current	I _{IH} (N1)	VN1 = VREG	-10	0	10	μA
Low-level input current	I _{IL} (N1)	VN1 = 0V	-130	-100		μA

LB11620T

Package Dimensions

unit : mm (typ)

3260A

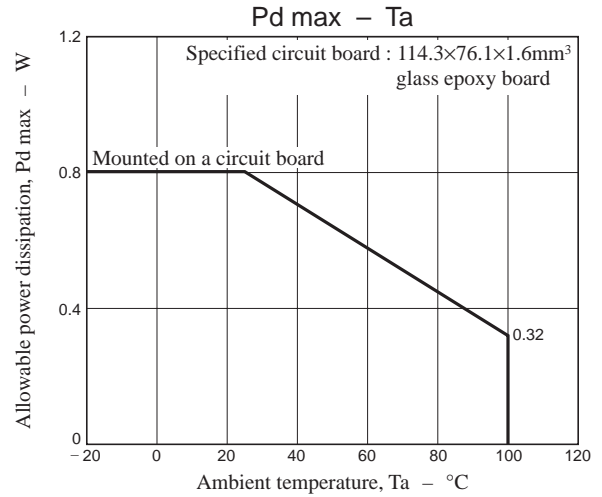
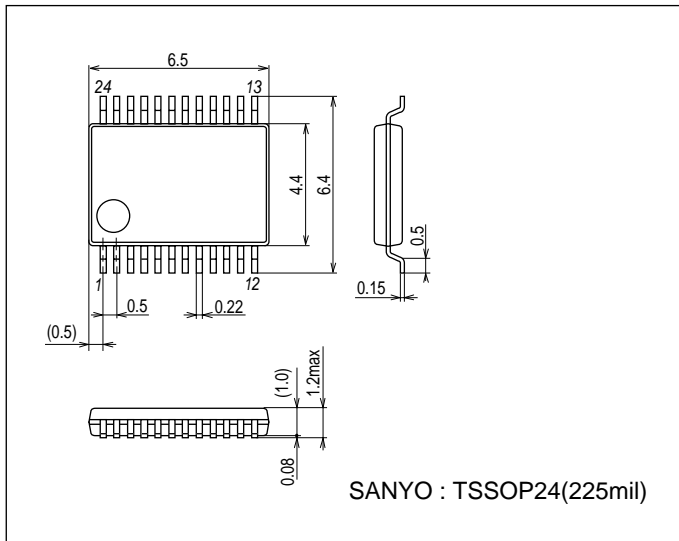

Pin Assignment

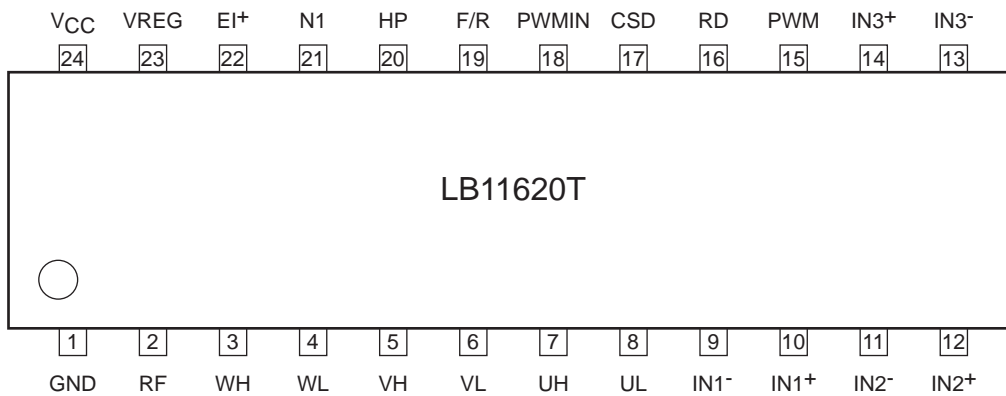

- Three-Phase Logic Truth Table (IN = "H" indicates the state where $IN^+ > IN^-$)

	F/R = "L"			F/R = "H"			Output	
	IN1	IN2	IN3	IN1	IN2	IN3	PWM	
1	H	L	H	L	H	L	VH	UL
2	H	L	L	L	H	H	WH	UL
3	H	H	L	L	L	H	WH	VL
4	L	H	L	H	L	H	UH	VL
5	L	H	H	H	L	L	UH	WL
6	L	L	H	H	H	L	VH	WL

- PWMIN pin

Input state	State
High or open	Output off
Low	Output on

If the PWM pin is not used, the input must be held at the low level.

- N1 pin

Input state	HP output
High or open	Three Hall sensor synthesized output
Low	Single Hall sensor output

LB11620T

Pin Functions [查询"LB11620T"供应商](#)

Pin No.	Pin	Description
1	GND	Ground
2	RF	Output current detection. The current detection resistor (Rf) voltage is sensed by the RF pin to implement current detection. The maximum output current is set by RF to be $I_{OUT} = 0.25/R_f$.
7 5 3	UH VH WH	Outputs (PWM outputs). These are push-pull outputs.
8 6 4	UL VL WL	Outputs These are push-pull outputs.
10, 9 12, 11 14, 13	IN1+, IN1- IN2+, IN2- IN3+, IN3-	Hall sensor inputs from each motor phase. The logic high state indicates that $IN^+ > IN^-$. If inputs are provided by a Hall effect sensor IC, the common-mode input range is expanded by biasing either the + or - input.
15	PWM	Functions as both the PWM oscillator frequency setting pin and the initial reset pulse setting pin. Connect a capacitor between this pin and ground.
16	RD	Lock (motor constrained) detection state output. This output is turned on when the motor is turning and off when the lock protection function detects that the motor has been stopped. This is an open collector output.
17	CSD	Sets the operating time for the lock protection circuit. Connect a capacitor between this pin and ground. Connect this pin to ground if the lock protection function is not used.
18	PWMIN	PWM pulse signal input. The output goes to the drive state when this pin is low, and to the off state when this pin is high or open. To use this pin for control, a CTL amplifier input such that the TOC pin voltage goes to the 100% duty state must be provided.
19	F/R	Forward/reverse control input
20	HP	Hall signal output (HP output). This provides either a single Hall sensor output or a synthesized 3-sensor output.
21	N1	Hall signal output (HP output) selection
22	EI+	CTL amplifier + (noninverting) input. The PWMIN pin must be held at the low level to use this input for motor control
23	VREG	5V regulator output (Used as the control circuit power supply. A low-voltage protection circuit is built in.) Connect a capacitor between this pin and ground for stabilization.
24	VCC	Power supply. Connect a capacitor between this pin and ground to prevent noise and other disturbances from affecting this IC.

LB11620T

Hall Sensor Signal Input/Output Timing Chart

[查询"LB11620T"供应商](#)

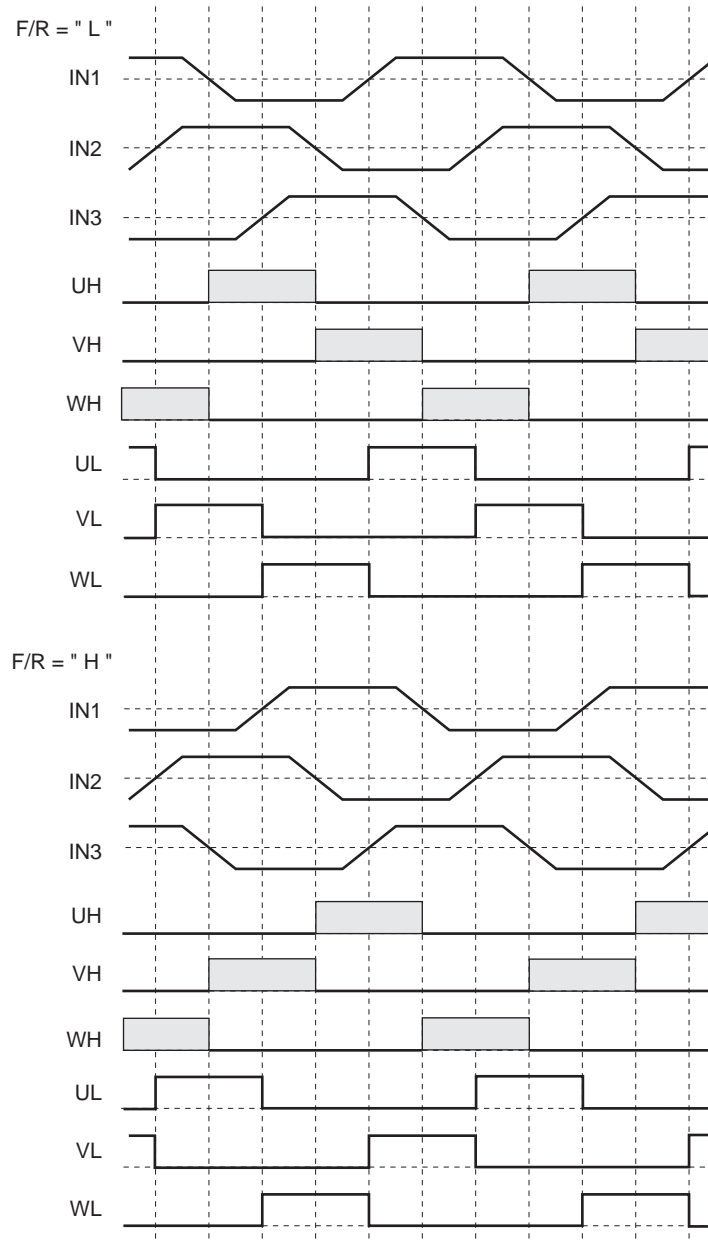

 Sections shown in gray are PWM output periods.

LB11620T

Block Diagram and Application Example 1

Bipolar transistor drive (high side PWM)
using a 5V power supply

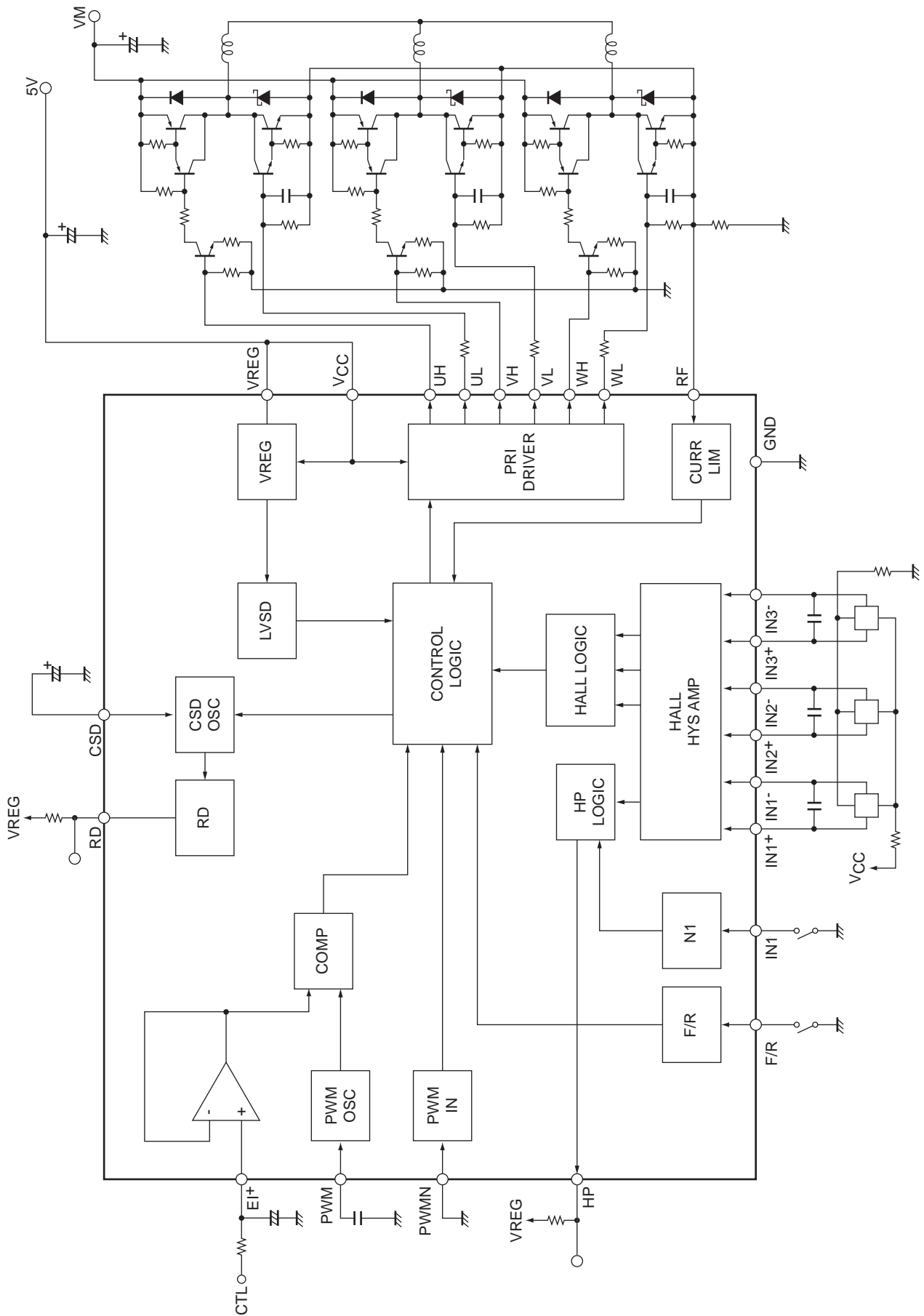

Application Example 2

34 MOS transistor drive (low side PWM)
using a 12V single-voltage power supply

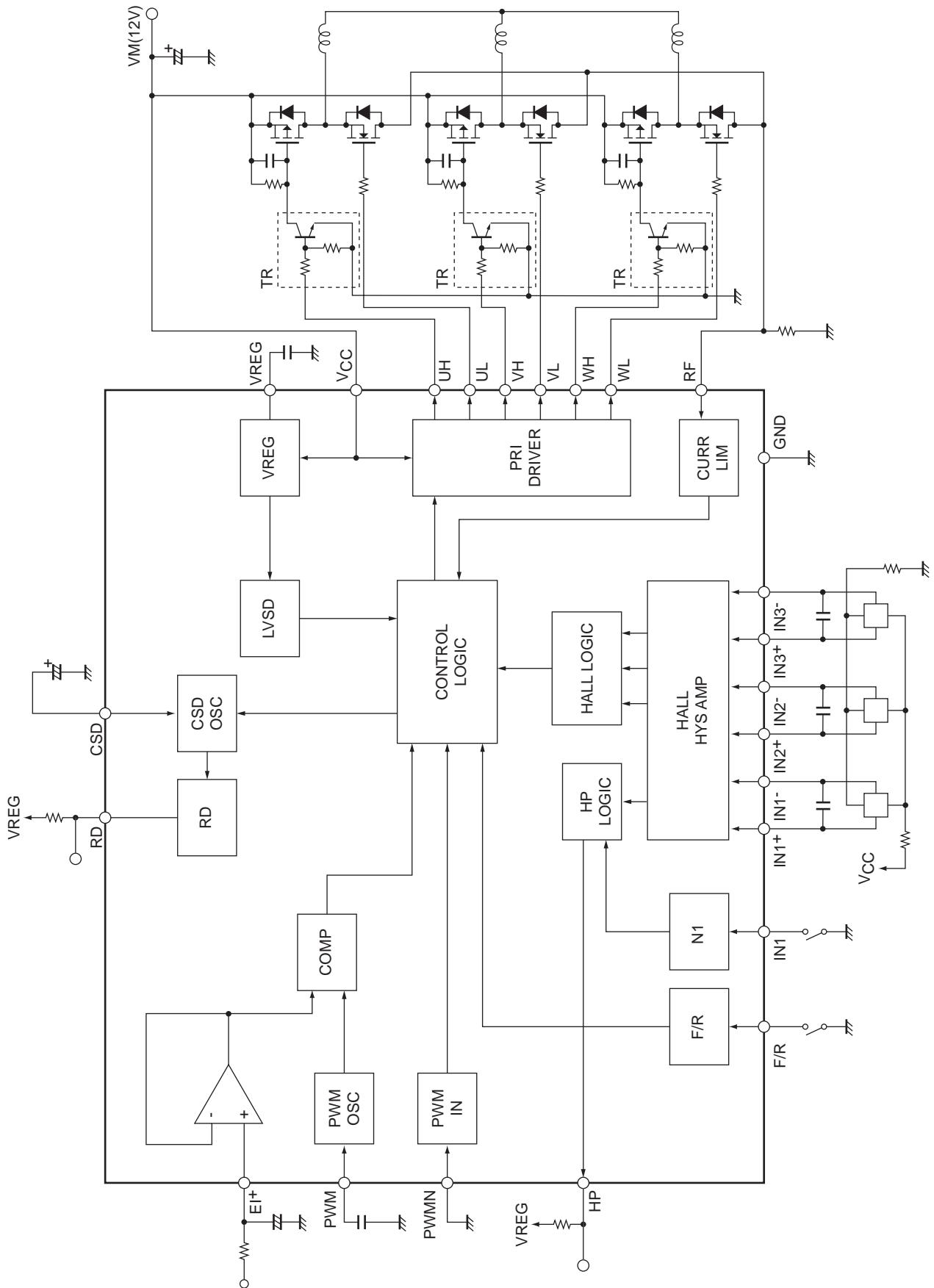

Application Example 3

MOS transistor drive (low side PWM)

using a $V_{CC} = 12V$, $V_M = 24V$ power supply system

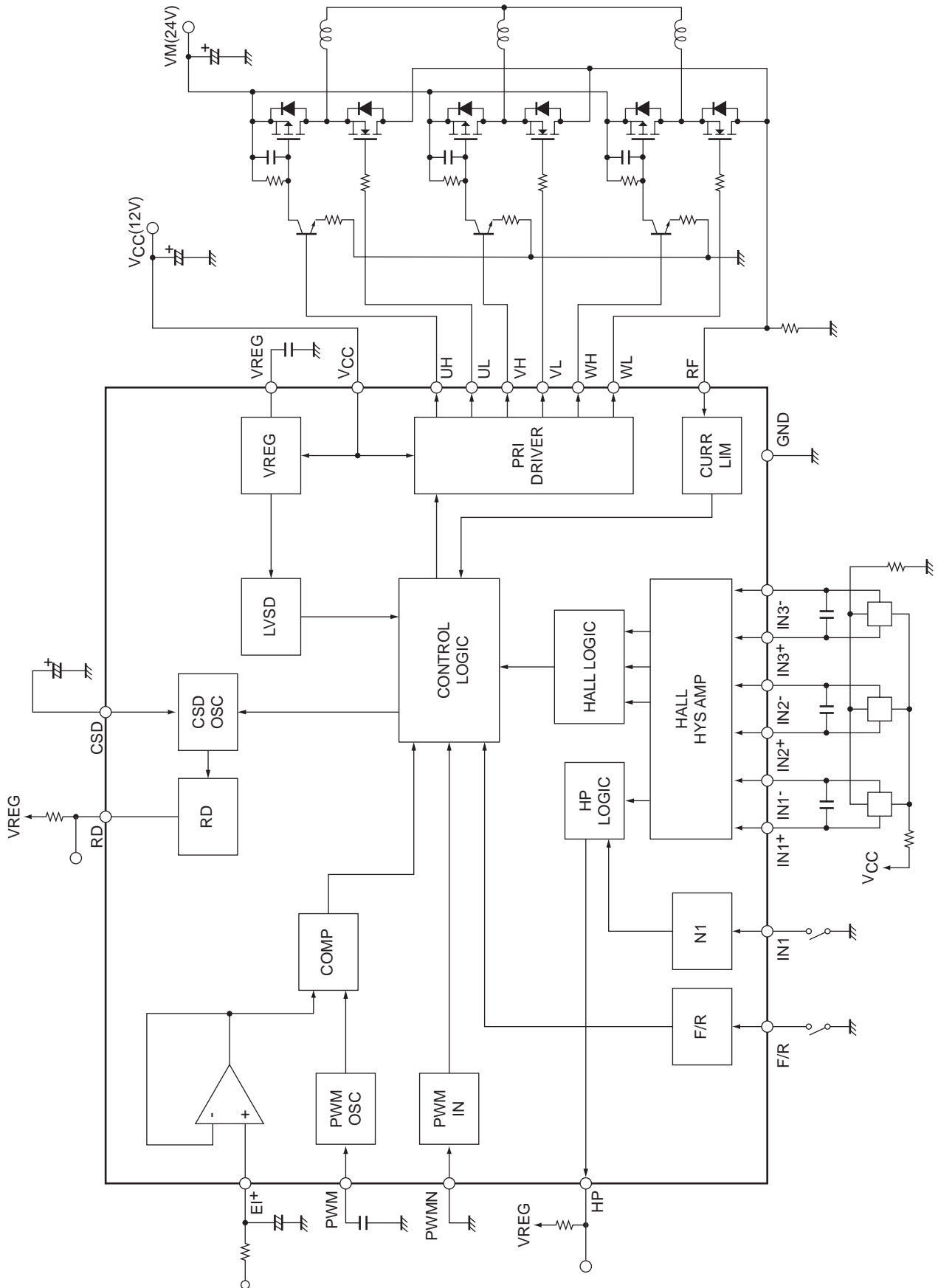

Application Example 4

MOS transistor drive (low side PWM)
using a 24V single-voltage power supply

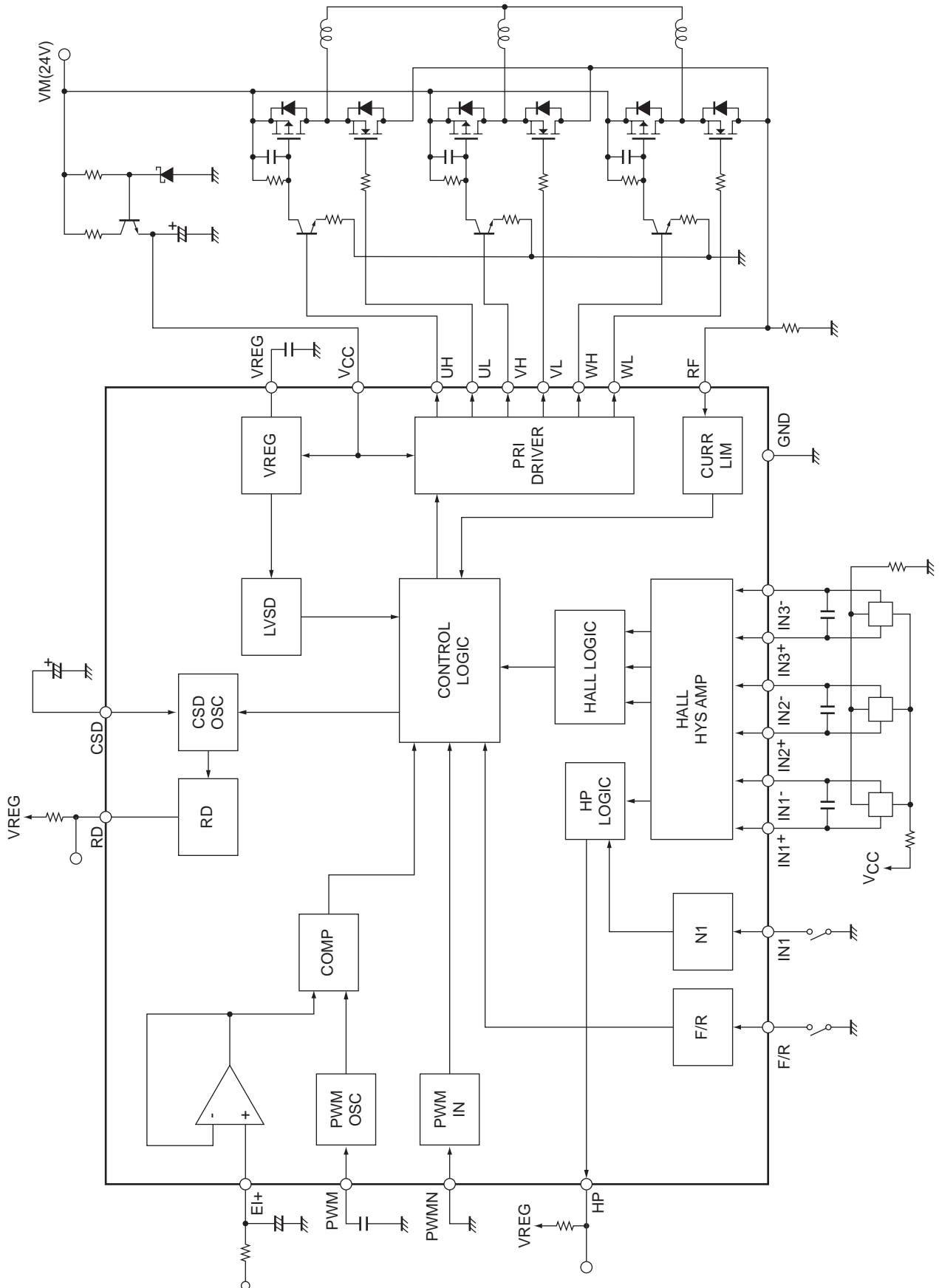

- SANYO Semiconductor Co.,Ltd. assumes no responsibility for equipment failures that result from using products at values that exceed, even momentarily, rated values (such as maximum ratings, operating condition ranges, or other parameters) listed in products specifications of any and all SANYO Semiconductor Co.,Ltd. products described or contained herein.
- SANYO Semiconductor Co.,Ltd. strives to supply high-quality high-reliability products, however, any and all semiconductor products fail or malfunction with some probability. It is possible that these probabilistic failures or malfunction could give rise to accidents or events that could endanger human lives, trouble that could give rise to smoke or fire, or accidents that could cause damage to other property. When designing equipment, adopt safety measures so that these kinds of accidents or events cannot occur. Such measures include but are not limited to protective circuits and error prevention circuits for safe design, redundant design, and structural design.
- In the event that any or all SANYO Semiconductor Co.,Ltd. products described or contained herein are controlled under any of applicable local export control laws and regulations, such products may require the export license from the authorities concerned in accordance with the above law.
- No part of this publication may be reproduced or transmitted in any form or by any means, electronic or mechanical, including photocopying and recording, or any information storage or retrieval system, or otherwise, without the prior written consent of SANYO Semiconductor Co.,Ltd.
- Any and all information described or contained herein are subject to change without notice due to product/technology improvement, etc. When designing equipment, refer to the "Delivery Specification" for the SANYO Semiconductor Co.,Ltd. product that you intend to use.
- Information (including circuit diagrams and circuit parameters) herein is for example only; it is not guaranteed for volume production.
- Upon using the technical information or products described herein, neither warranty nor license shall be granted with regard to intellectual property rights or any other rights of SANYO Semiconductor Co.,Ltd. or any third party. SANYO Semiconductor Co.,Ltd. shall not be liable for any claim or suits with regard to a third party's intellectual property rights which has resulted from the use of the technical information and products mentioned above.

This catalog provides information as of February, 2007. Specifications and information herein are subject to change without notice.