

**T-3/4 Sub Miniature LED Lamps**

**DESCRIPTION AND FEATURES**

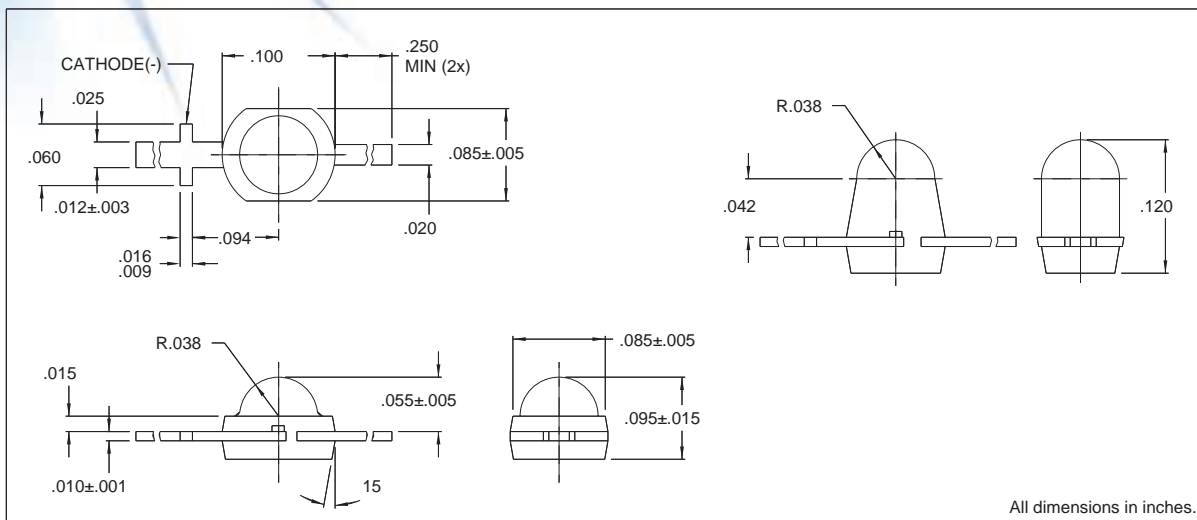

These subminiature LED lamps are intended for high volume, low cost status indication on P.C. boards and for backlighting switches and keyboard keys. The lamps are compatible with vapor phase reflow surface mount and conventional soldering techniques.

**ELECTRO-OPTICAL CHARACTERISTICS AND RATINGS**

PART NUMBER	HLMP0300	HLMP0301	HLMP0400	HLMP0401	HLMP0503	HLMP0504
Output Color	H.E.Red	H.E.Red	Yellow	Yellow	H.E.Green	H.E.Green
Diffusion	Diffused	Diffused	Diffused	Diffused	Diffused	Diffused
Package Color	Red	Red	Yellow	Yellow	Green	Green
Test Current (mA)	20	20	20	20	20	20
Forward Voltage Typ. (V)	2.1	2.1	2.2	2.2	2.3	2.3
Forward Voltage Max. (V)	3.0	3.0	3.0	3.0	3.0	3.0
Luminous Intensity Min. (mcd)	1.0	2.5	1.5	3.0	1.5	2.5
Luminous Intensity Typ. (mcd)	2.5	5.0	2.5	5.0	3.0	5.0
Average Forward Current (mA)	30	30	30	30	30	30
Peak Wavelength (nm)	635	635	585	585	565	565
Viewing Angle 20 1/2 (degrees)	100	100	100	100	100	100
Power Dissipation (mW)	135	135	135	135	135	135
Operating Temperature (°C)	-55 to +100	-55 to +100	-55 to +100	-55 to +100	-55 to +100	-55 to +100
Storage Temperature (°C)	-55 to +100	-55 to +100	-55 to +100	-55 to +100	-55 to +100	-55 to +100
Peak Forward Current Max. (1µs @ 0.3% duty cycle) (mA)	90	90	90	90	90	90
Reverse Voltage (IR=100µA) (V)	5	5	5	5	5	5
Lead Solder Time @ 260 °C	5	5	5	5	5	5