

OVERVOLTAGE AND OVERCURRENT PROTECTION IC AND Li+ CHARGER FRONT-END PROTECTION IC

FEATURES

- Provides Protection for Three Variables:
 - Input Overvoltage
 - Input Overcurrent (User-Programmable)
 - Battery Overvoltage
- 30V Maximum Input Voltage
- Supports up to 1.5A Input Current
- High Immunity Against False Triggering Due to Voltage Spikes
- Robust Against False Triggering Due to Current Transients
- Thermal Shutdown
- Status Indication – Fault Condition

- Available in Space-Saving Small 8 Lead 2x2 SON and 12 Lead 4x3 SON Packages

APPLICATIONS

- Smart Phones
- PDAs
- MP3 Players
- Low-Power Handheld Devices
- Bluetooth Headsets

DESCRIPTION

The bq24314 and bq24316 are highly integrated circuits designed to provide protection to Li-ion batteries from failures of the charging circuit. The IC continuously monitors the input voltage, the input current, and the battery voltage. In case of an input overvoltage condition, the IC immediately removes power from the charging circuit by turning off an internal switch. In the case of an overcurrent condition, it limits the system current at the threshold value, and if the overcurrent persists, switches the pass element OFF after a blanking period. Additionally, the IC also monitors its own die temperature and switches off if it becomes too hot. The input overcurrent threshold is user-programmable.

The IC can be controlled by a processor and also provides status information about fault conditions to the host.

APPLICATION SCHEMATIC

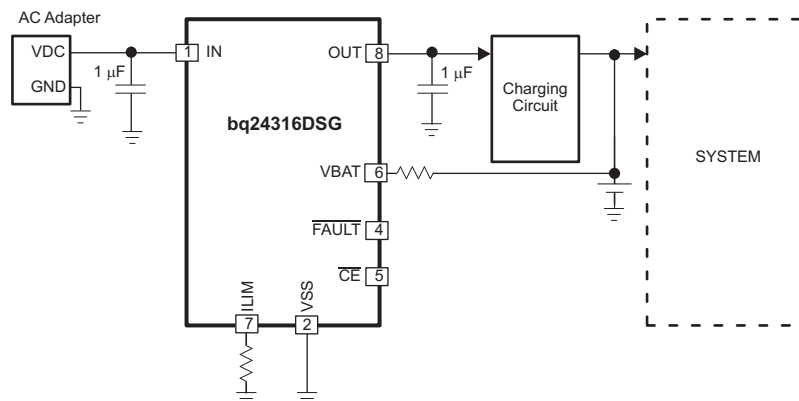

Please be aware that an important notice concerning availability, standard warranty, and use in critical applications of Texas Instruments semiconductor products and disclaimers thereto appears at the end of this data sheet.



These devices have limited built-in ESD protection. The leads should be shorted together or the device placed in conductive foam during storage or handling to prevent electrostatic damage to the MOS gates.

SIMPLIFIED BLOCK DIAGRAM

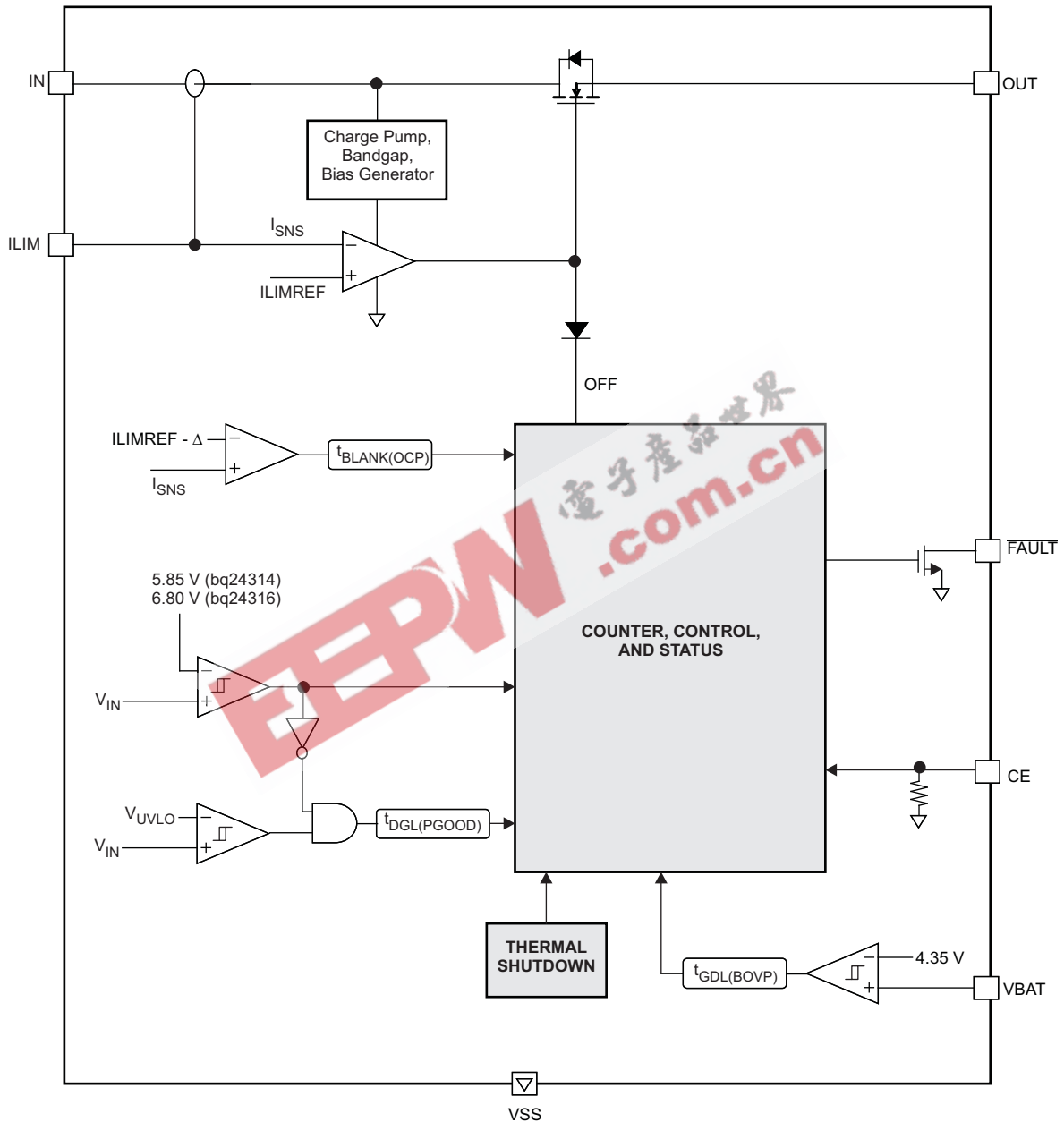

PRODUCT PREVIEW

TERMINAL FUNCTIONS

| TERMINAL | | | I/O | DESCRIPTION |
|----------|--------|-----|-----|--|
| NAME | DSJ | DSG | | |
| IN | 1, 2 | 1 | I | Input power, connect to external DC supply. Connect external 1µF capacitor (minimum) to VSS. For the 12 pin (DSJ-suffix) device, ensure that pins 1 and 2 are connected together on the PCB at the device. |
| OUT | 10, 11 | 8 | O | Output terminal to the charging system. Connect external 1µF capacitor (minimum) to VSS. |
| VBAT | 8 | 6 | I | Battery voltage sense input. Connect to pack positive terminal through a resistor. |

| TERMINAL | | | I/O | DESCRIPTION |
|-----------------|----------|-----|-----|---|
| NAME | DSJ | DSG | | |
| ILIM | 9 | 7 | I/O | Input overcurrent threshold programming. Connect a resistor to VSS to set the overcurrent threshold. |
| \overline{CE} | 7 | 5 | I | Chip enable input. Active low. When \overline{CE} = High, the input FET is off. Internally pulled down. |
| FAULT | 4 | 4 | O | Open-drain output, device status. \overline{FAULT} = Low indicates that the input FET has been turned off due to input overvoltage or input overcurrent conditions, or because the battery voltage is outside safe limits. |
| VSS | 3 | 2 | – | Ground terminal |
| NC | 5, 6, 12 | 3 | | These pins may have internal circuits used for test purposes. Do not make any external connections at these pins for normal operation. |
| Thermal PAD | | | – | There is an internal electrical connection between the exposed thermal pad and the VSS pin of the device. The thermal pad must be connected to the same potential as the VSS pin on the printed circuit board. Do not use the thermal pad as the primary ground input for the device. The VSS pin must be connected to ground at all times. |

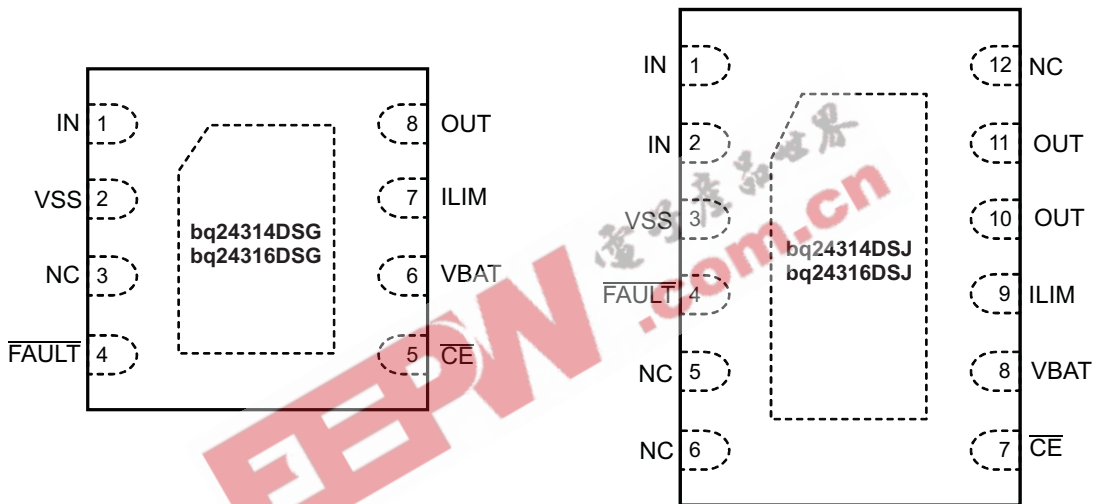

ABSOLUTE MAXIMUM RATINGS⁽¹⁾

over operating free-air temperature range (unless otherwise noted)

| PARAMETER | PIN | VALUE | UNIT |
|--|---|------------|------|
| Input voltage | IN (with respect to VSS) | –0.3 to 30 | V |
| | OUT (with respect to VSS) | –0.3 to 12 | |
| | ILIM, \overline{FAULT} , \overline{CE} , VBAT (with respect to VSS) | –0.3 to 7 | |
| Input current | IN | 2.0 | A |
| Output current | OUT | 2.0 | A |
| Output sink current | \overline{FAULT} | 15 | mA |
| Junction temperature, T_J | | –40 to 150 | °C |
| Storage temperature, T_{STG} | | –65 to 150 | °C |
| Lead temperature (soldering, 10 seconds) | | 300 | °C |

- (1) Stresses beyond those listed under absolute maximum ratings may cause permanent damage to the device. These are stress ratings only, and functional operation of the device at these or any other conditions beyond those indicated under recommended operating conditions is not implied. Exposure to absolute-maximum-rated conditions for extended periods may affect device reliability. All voltage values are with respect to the network ground terminal unless otherwise noted.

PACKAGE DISSIPATION RATINGS

| PART NO. | PACKAGE | R _{θJC} | R _{θJA} | T _A ≤ 25°C POWER RATING | DERATING FACTOR T _A > 25°C |
|--------------------------|---------|------------------|------------------|---------------------------------------|--|
| BQ24314DSG BQ24316DSG | 2×2 SON | | | | |
| BQ24314DSJ BQ24316DSJ | 4×3 SON | | | | |

RECOMMENDED OPERATING CONDITIONS

over operating free-air temperature range (unless otherwise noted)

| | | MIN | MAX | UNIT |
|-------------------|--------------------------|-------|-------|------|
| V _{IN} | Input voltage range | 3.3 | 26 | V |
| I _{IN} | Input current, IN pin | | 1.5 | A |
| I _{OUT} | Output current, OUT pin | | 1.5 | A |
| R _{ILIM} | OCP Programming resistor | 16.67 | 83.33 | kΩ |
| T _J | Junction temperature | 0 | 125 | °C |

ELECTRICAL CHARACTERISTICS

over junction temperature range 0°C ≤ T_J ≤ 125°C and recommended supply voltage (unless otherwise noted)

| PARAMETER | | TEST CONDITIONS | MIN | TYP | MAX | UNIT |
|--|--|---|------|-------|------|------|
| IN | | | | | | |
| V _{UVLO} | Under-voltage lock-out, input power detected threshold | \overline{CE} = Low or High, V _{IN} : 2V → 3V | 2.5 | | 2.8 | V |
| V _{HYS-UVLO} | Hysteresis on UVLO | \overline{CE} = Low or High, V _{IN} : 3V → 2V | 200 | | 300 | mV |
| T _{DGL(PGOOD)} | Deglintch time, input power detected status | \overline{CE} = Low or High. Time measured from V _{IN} 0V → 5V 1μs rise-time, to output turning ON | | 8 | | ms |
| I _{DD} | Operating current | \overline{CE} = Low, No load on OUT pin, V _{IN} < 6V | | 600 | | μA |
| I _{STDBY} | Standby current | \overline{CE} = High, V _{IN} < 6V | | 55 | | μA |
| INPUT TO OUTPUT CHARACTERISTICS | | | | | | |
| V _{DO} | Drop-out voltage IN to OUT | \overline{CE} = Low, V _{IN} = 5V, I _{OUT} = 1A | | | 300 | mV |
| INPUT OVERVOLTAGE PROTECTION | | | | | | |
| V _{OVP} | Input overvoltage protection threshold (bq24314) | | 5.67 | 5.85 | 6.00 | V |
| | Input overvoltage protection threshold (bq24316) | | 6.60 | 6.80 | 7.00 | V |
| t _{PD(OVP)} | Input OV propagation delay | \overline{CE} = Low | | | 1 | μs |
| V _{HYS-OVP} | Hysteresis on OVP | \overline{CE} = Low or High, V _{IN} : 7.5V → 5V | | 60 | | mV |
| t _{ON(OVP)} | Recovery time from input overvoltage condition | \overline{CE} = Low, Time measured from V _{IN} 7.5V → 5V, 1μs fall-time | | 8 | | ms |
| INPUT OVERCURRENT PROTECTION | | | | | | |
| I _{OCP} | Input overcurrent protection threshold range | \overline{CE} = Low, R _{ILIM} = 16.67kΩ to 83.33kΩ | 300 | | 1500 | mA |
| ΔI _{OCP} | OCP threshold accuracy | \overline{CE} = Low, R _{ILIM} = 16.67kΩ to 83.33kΩ | | ±10 % | | |
| I _{OCP} | Input overcurrent protection threshold | \overline{CE} = Low, R _{ILIM} = 25kΩ | 930 | 1000 | 1070 | mA |
| K _{ILIM} | Current limit programming: I _{OCP} = K _{ILIM} ÷ R _{ILIM} | | | 25000 | | AΩ |
| t _{BLANK(OCP)} | Blanking time, input overcurrent detected | \overline{CE} = Low | | 176 | | μs |
| t _{ON(OCP)} | Recovery time from input overcurrent condition | \overline{CE} = Low | | 64 | | ms |
| BATTERY OVERVOLTAGE PROTECTION | | | | | | |

ELECTRICAL CHARACTERISTICS (continued)

over junction temperature range $0^{\circ}\text{C} \leq T_J \leq 125^{\circ}\text{C}$ and recommended supply voltage (unless otherwise noted)

| PARAMETER | TEST CONDITIONS | MIN | TYP | MAX | UNIT |
|---|--|------|------|-----|--------------------|
| BV_{OVP} | Battery overvoltage protection threshold $\overline{CE} = \text{Low}, V_{IN} > 4.3\text{V}$ | 4.30 | 4.35 | 4.4 | V |
| $V_{HYS-BOVP}$ | Hysteresis on BV_{OVP} $\overline{CE} = \text{Low}, V_{IN} > 4.3\text{V}$ | | 270 | | mV |
| I_{VBAT} | Input bias current on VBAT pin $\overline{CE} = \text{Low}, V_{IN} > 4.3\text{V}$ | | | 20 | nA |
| $T_{DGL(BOVP)}$ | Deglintch time, battery overvoltage detected $\overline{CE} = \text{Low}, V_{IN} > 4.3\text{V}$ | | 176 | | μs |
| THERMAL PROTECTION | | | | | |
| $T_{J(OFF)}$ | Thermal shutdown temperature | | 140 | 150 | $^{\circ}\text{C}$ |
| $T_{J(OFF-HYS)}$ | Thermal shutdown hysteresis | | 20 | | $^{\circ}\text{C}$ |
| LOGIC LEVELS ON \overline{CE} | | | | | |
| V_{IL} | Low-level input voltage | 0 | | 0.4 | V |
| V_{IH} | High-level input voltage | 1.4 | | | V |
| I_{IL} | Low-level input current $V_{CE} = 0\text{V}$ | | | 1 | μA |
| I_{IH} | High-level input current $V_{CE} = 1.8\text{V}$ | | | 10 | μA |
| LOGIC LEVELS ON FAULT | | | | | |
| V_{OL} | Output low voltage $I_{SINK} = 5\text{mA}$ | | | 0.4 | V |

TYPICAL OPERATING PERFORMANCE

For Figure 1 through Figure 4, $V_{IN} = 5\text{V}$ to 12V , $C_{OUT} = 0.47\ \mu\text{F}$, $R_{OUT} = 33\ \Omega$, $R_{ILIM} = 25\ \text{k}\Omega$, Channel 1 = V_{IN} , Channel 2 = V_{OUT} , Channel 4 = FAULT

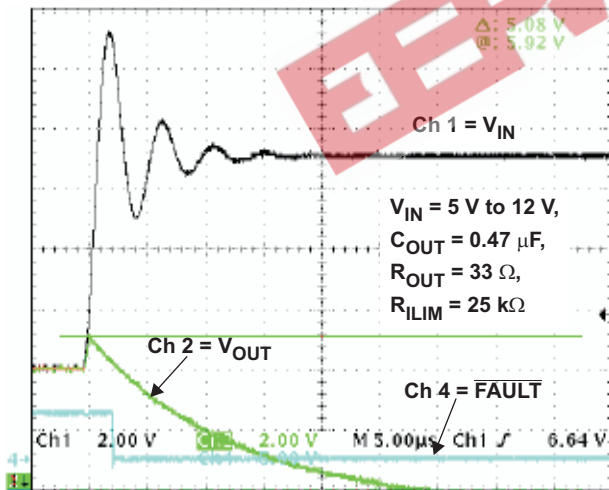

Figure 1. bq24314 OVP Response for Input Step, $t_R = 1\ \mu\text{s}$

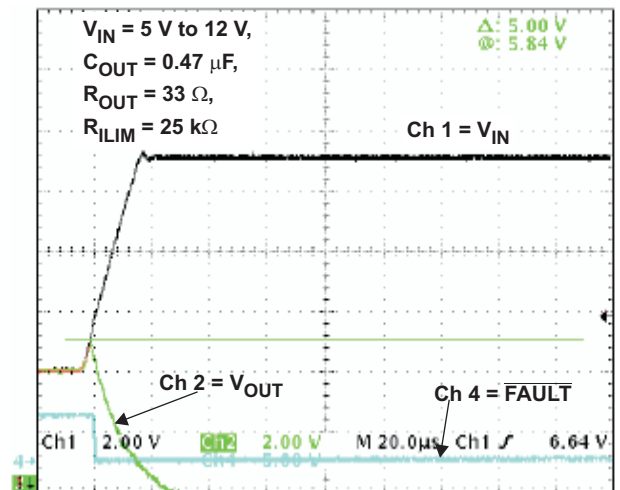

Figure 2. bq24314 OVP Response for Input Step, $t_R = 20\ \mu\text{s}$

TYPICAL OPERATING PERFORMANCE (continued)

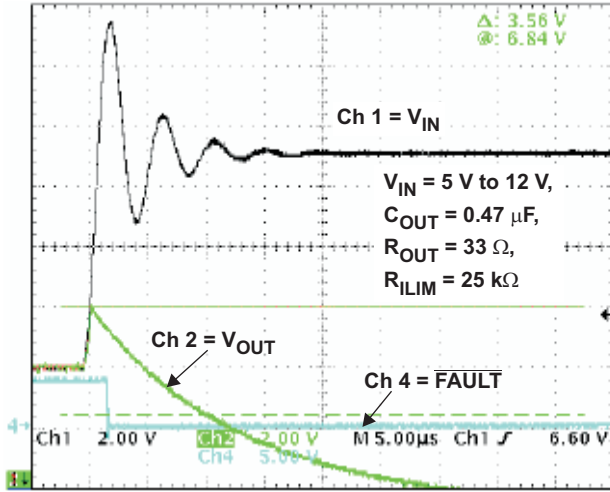

Figure 3. bq24316 OVP Response for Input Step, $t_R = 1\ \mu\text{s}$

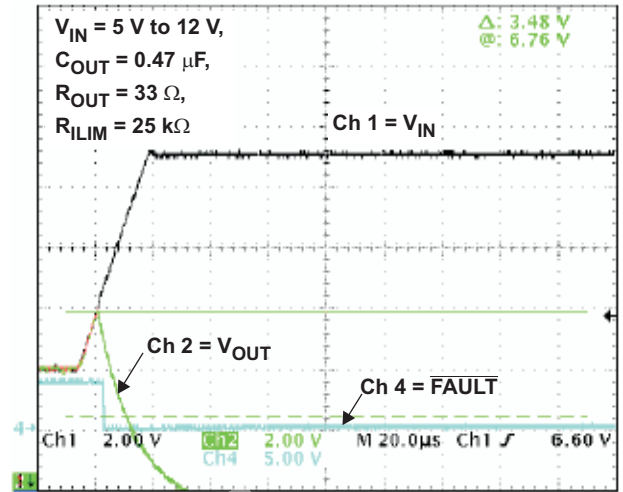

Figure 4. bq24316 OVP Response for Input Step, $t_R = 20\ \mu\text{s}$

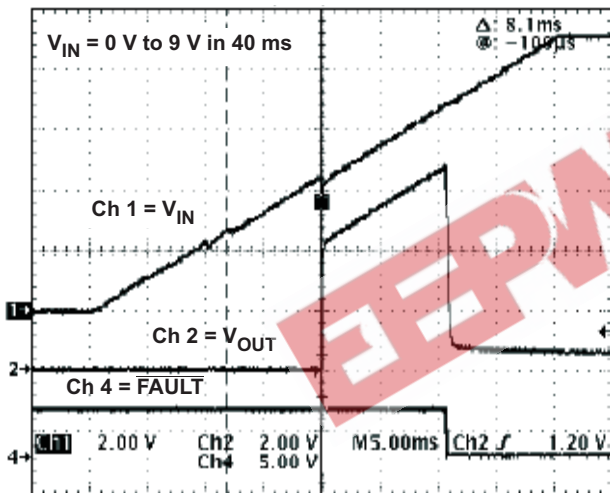

Figure 5. bq24316 Response for Slow Input Ramp
Channel 1 = V_{IN} , Channel 2 = V_{OUT} , Channel 4 = FAULT,
 $V_{IN} = 0\text{ V to }9\text{ V in }40\text{ ms}$

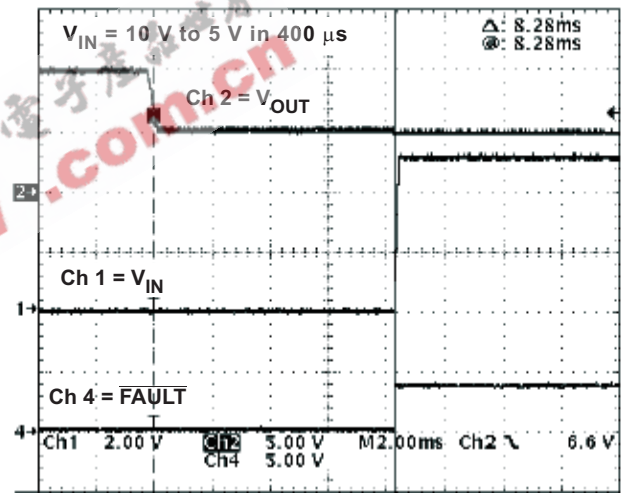

Figure 6. bq24316 Recovery From OVP
Channel 2 = V_{IN} ,
Channel 1 = V_{OUT} , Channel 4 = FAULT, $V_{IN} = 10\text{ V to }5\text{ V in }400\ \mu\text{s}$

PRODUCT PREVIEW

TYPICAL OPERATING PERFORMANCE (continued)

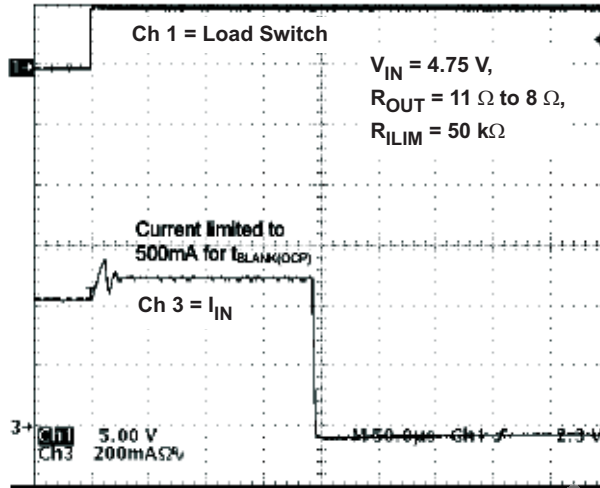

Figure 7. bq24316 OCP Response
Channel 1 = Load Switch, Channel 3 = I_{IN} , $V_{IN} = 4.75V$,
 $R_{ILIM} = 50k\Omega$, $R_{OUT} = 11\Omega$ to 8Ω

TYPICAL APPLICATION CIRCUIT

(Terminal numbers shown are for the 2x2 DSG package)

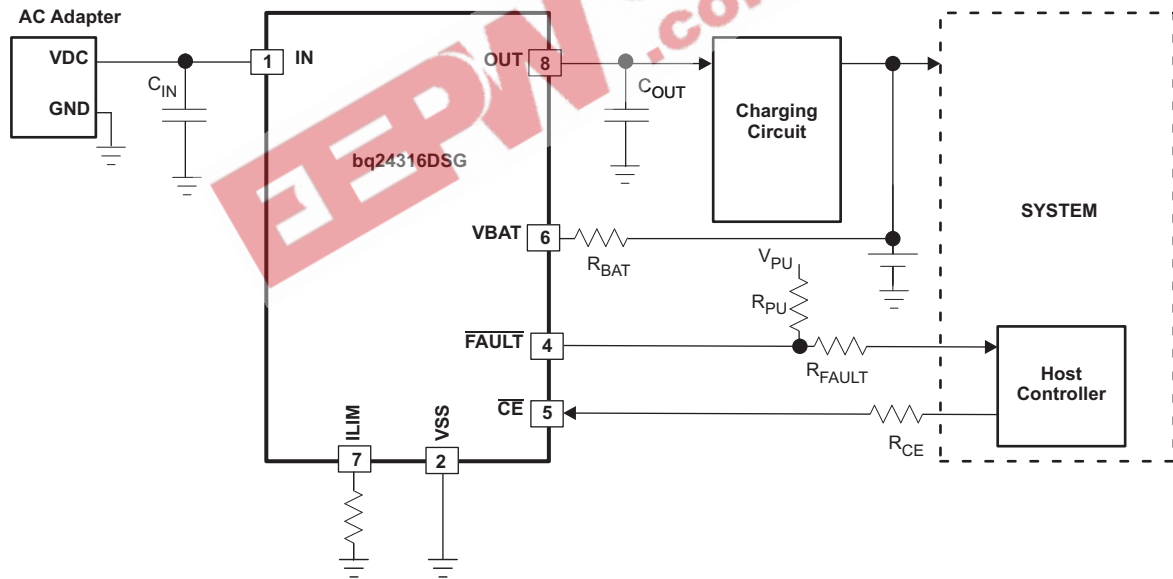

Figure 8. Simple Protection

DETAILED FUNCTIONAL DESCRIPTION

POWER DOWN

The device remains in power down mode when the input voltage at the IN pin is below the undervoltage threshold V_{UVLO} . The FET Q1 connected between IN and OUT pins is off, and the status output, \overline{FAULT} , is set to Hi-Z.

PRODUCT PREVIEW

POWER-ON RESET

The device resets when the input voltage at the IN pin exceeds the UVLO threshold. All internal counters and other circuit blocks are reset.

OPERATION

The device continuously monitors the input voltage, the input current, and the battery voltage.

Input Overvoltage Protection

If the input voltage rises above V_{OVP} , the internal FET is turned off, removing power from the circuit. The $\overline{\text{FAULT}}$ pin is driven low. When the input voltage returns below $V_{OVP} - V_{HYS-OVP}$ (but is still above V_{UVLO}), the FET is turned on again after a deglitch time of $t_{ON(OVP)}$ to ensure that the input supply has stabilized.

Input Overcurrent Protection

The overcurrent threshold is programmed by a resistor R_{ILIM} connected from the ILIM pin to VSS. The overcurrent threshold is given by $I_{OCP} = K_{ILIM} \div R_{ILIM}$.

If the load current tries to exceed the I_{OCP} threshold, the device limits the current for a blanking duration of $t_{BLANK(OCP)}$. If the load current returns to less than I_{OCP} before $t_{BLANK(OCP)}$ times out, the device continues to operate. However, if the overcurrent situation persists for $t_{BLANK(OCP)}$, the FET is turned off for a duration of $t_{ON(OCP)}$, and the $\overline{\text{FAULT}}$ pin is driven low. The FET is then turned on again after $t_{ON(OCP)}$ and the current is monitored all over again. Each time an OCP fault occurs, an internal counter is incremented. If 15 OCP faults occur in one charge cycle, the FET is turned off permanently. The counter is cleared either by removing and re-applying input power, or by disabling and re-enabling the device with the $\overline{\text{CE}}$ pin.

Battery Overvoltage Protection

The battery overvoltage threshold BV_{OVP} is internally set to 4.35V. If the battery voltage exceeds the BV_{OVP} threshold, the FET is turned off, and the $\overline{\text{FAULT}}$ pin is driven low. The FET is turned back on once the battery voltage drops to $BV_{OVP} - V_{HYS-BOVP}$. Each time a battery overvoltage fault occurs, an internal counter is incremented. If 15 such faults occur in one charge cycle, the FET is turned off permanently. The counter is cleared either by removing and re-applying input power, or by disabling and re-enabling the device with the $\overline{\text{CE}}$ pin.

THERMAL PROTECTION

If the junction temperature of the device exceeds $T_{J(OFF)}$, the FET is turned off, and the $\overline{\text{FAULT}}$ pin is driven low. The FET is turned back on when the junction temperature falls below $T_{J(OFF)} - T_{J(OFF-HYS)}$.

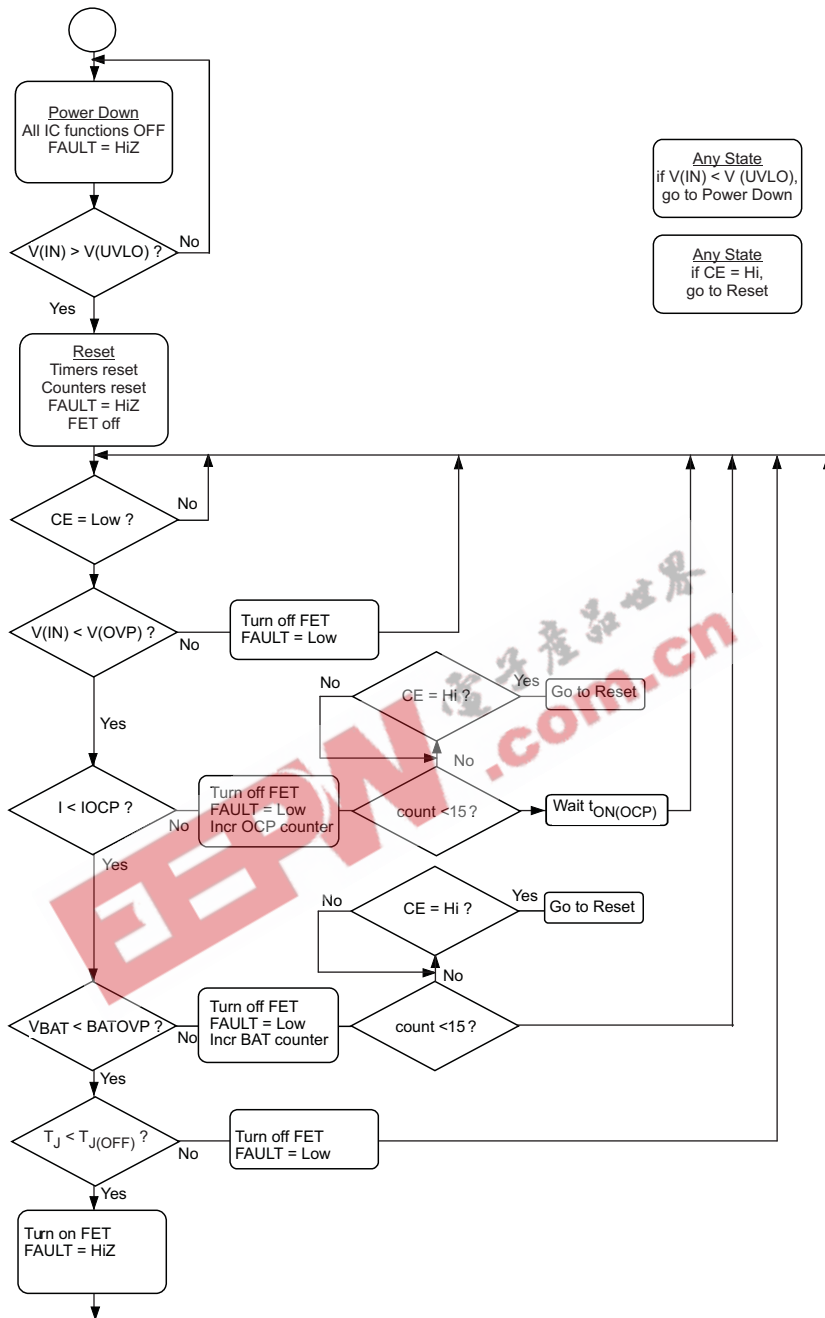

Figure 9. Flow Diagram

\overline{CE} Pin

The IC has an enable pin which can be used to enable or disable the device. When the \overline{CE} pin is driven high, the internal FET is turned off. When the \overline{CE} pin is low, the FET is turned on if other conditions are safe. The \overline{CE} pin has an internal pulldown resistor and can be left floating. Note that the \overline{FAULT} pin functionality is also disabled when the \overline{CE} pin is high.

APPLICATION INFORMATION (WITH REFERENCE TO [FIGURE 8](#))

Selection of R_{BAT}

It is strongly recommended that the battery not be tied directly to the VBAT pin of the device, as under some failure modes of the IC, the voltage at the IN pin may appear on the VBAT pin. This voltage can be as high as 30V, and applying 30V to the battery in case of the failure of the bq2431x can be hazardous. Connecting the VBAT pin through R_{BAT} prevents a large current from flowing into the battery in case of a failure of the IC. In the interests of safety, R_{BAT} should have a very high value. The problem with a large R_{BAT} is that the voltage drop across this resistor because of the VBAT bias current I_{VBAT} causes an error in the BV_{OVP} threshold. This error is over and above the tolerance on the nominal 4.35V BV_{OVP} threshold.

Choosing R_{BAT} equal to 220k Ω is a good compromise. In the case of an IC failure, the maximum current flowing into the battery would be $(30V - 3V) \div 220k\Omega = 123\mu A$, which is low enough to be absorbed by the bias currents of the system components. R_{BAT} equal to 220k Ω would result in a worst-case voltage drop of $R_{BAT} \times I_{VBAT} = 4.4mV$. This added to the internal tolerance of 50mV results in a total BV_{OVP} threshold error of less than 55mV, which should be acceptable in most applications.

Selection of R_{CE}

The \overline{CE} pin can be used to enable and disable the IC. If host control is not required, the \overline{CE} pin can be tied to ground or left un-connected, permanently enabling the device.

In applications where external control is required, the \overline{CE} pin can be controlled by a host processor. As in the case of the VBAT pin (see above), the \overline{CE} pin should be connected to the host GPIO pin through as large a resistor as possible. The limitation on the resistor value is that the minimum V_{OH} of the host GPIO pin less the drop across the resistor should be greater than V_{IH} of the bq2431x \overline{CE} pin. The drop across the resistor is given by $R_{CE} \times I_{IH}$.

FAULT Pin

The FAULT pin is an open-drain output that goes low during OV, OC, and battery-OV events. If the application does not require monitoring of the FAULT pin, it can be left unconnected. But if the FAULT pin has to be monitored, it should be pulled high externally through R_{PU} , and connected to the host through R_{FAULT} . R_{FAULT} prevents damage to the host controller if the bq2431x fails (see above). The resistors should be of high value, in practice values between 22k Ω and 100k Ω should be sufficient.

PACKAGING INFORMATION

| Orderable Device | Status ⁽¹⁾ | Package Type | Package Drawing | Pins | Package Qty | Eco Plan ⁽²⁾ | Lead/Ball Finish | MSL Peak Temp ⁽³⁾ |
|------------------|-----------------------|--------------|-----------------|------|-------------|-------------------------|------------------|------------------------------|
| BQ24314DSGR | PREVIEW | SON | DSG | 8 | 3000 | TBD | Call TI | Call TI |
| BQ24316DSGR | PREVIEW | SON | DSG | 8 | 3000 | TBD | Call TI | Call TI |

⁽¹⁾ The marketing status values are defined as follows:

ACTIVE: Product device recommended for new designs.

LIFEBUY: TI has announced that the device will be discontinued, and a lifetime-buy period is in effect.

NRND: Not recommended for new designs. Device is in production to support existing customers, but TI does not recommend using this part in a new design.

PREVIEW: Device has been announced but is not in production. Samples may or may not be available.

OBSOLETE: TI has discontinued the production of the device.

⁽²⁾ Eco Plan - The planned eco-friendly classification: Pb-Free (RoHS), Pb-Free (RoHS Exempt), or Green (RoHS & no Sb/Br) - please check <http://www.ti.com/productcontent> for the latest availability information and additional product content details.

TBD: The Pb-Free/Green conversion plan has not been defined.

Pb-Free (RoHS): TI's terms "Lead-Free" or "Pb-Free" mean semiconductor products that are compatible with the current RoHS requirements for all 6 substances, including the requirement that lead not exceed 0.1% by weight in homogeneous materials. Where designed to be soldered at high temperatures, TI Pb-Free products are suitable for use in specified lead-free processes.

Pb-Free (RoHS Exempt): This component has a RoHS exemption for either 1) lead-based flip-chip solder bumps used between the die and package, or 2) lead-based die adhesive used between the die and leadframe. The component is otherwise considered Pb-Free (RoHS compatible) as defined above.

Green (RoHS & no Sb/Br): TI defines "Green" to mean Pb-Free (RoHS compatible), and free of Bromine (Br) and Antimony (Sb) based flame retardants (Br or Sb do not exceed 0.1% by weight in homogeneous material)

⁽³⁾ MSL, Peak Temp. -- The Moisture Sensitivity Level rating according to the JEDEC industry standard classifications, and peak solder temperature.

Important Information and Disclaimer: The information provided on this page represents TI's knowledge and belief as of the date that it is provided. TI bases its knowledge and belief on information provided by third parties, and makes no representation or warranty as to the accuracy of such information. Efforts are underway to better integrate information from third parties. TI has taken and continues to take reasonable steps to provide representative and accurate information but may not have conducted destructive testing or chemical analysis on incoming materials and chemicals. TI and TI suppliers consider certain information to be proprietary, and thus CAS numbers and other limited information may not be available for release.

In no event shall TI's liability arising out of such information exceed the total purchase price of the TI part(s) at issue in this document sold by TI to Customer on an annual basis.

DSG (S-PDSO-N8)

PLASTIC SMALL OUTLINE

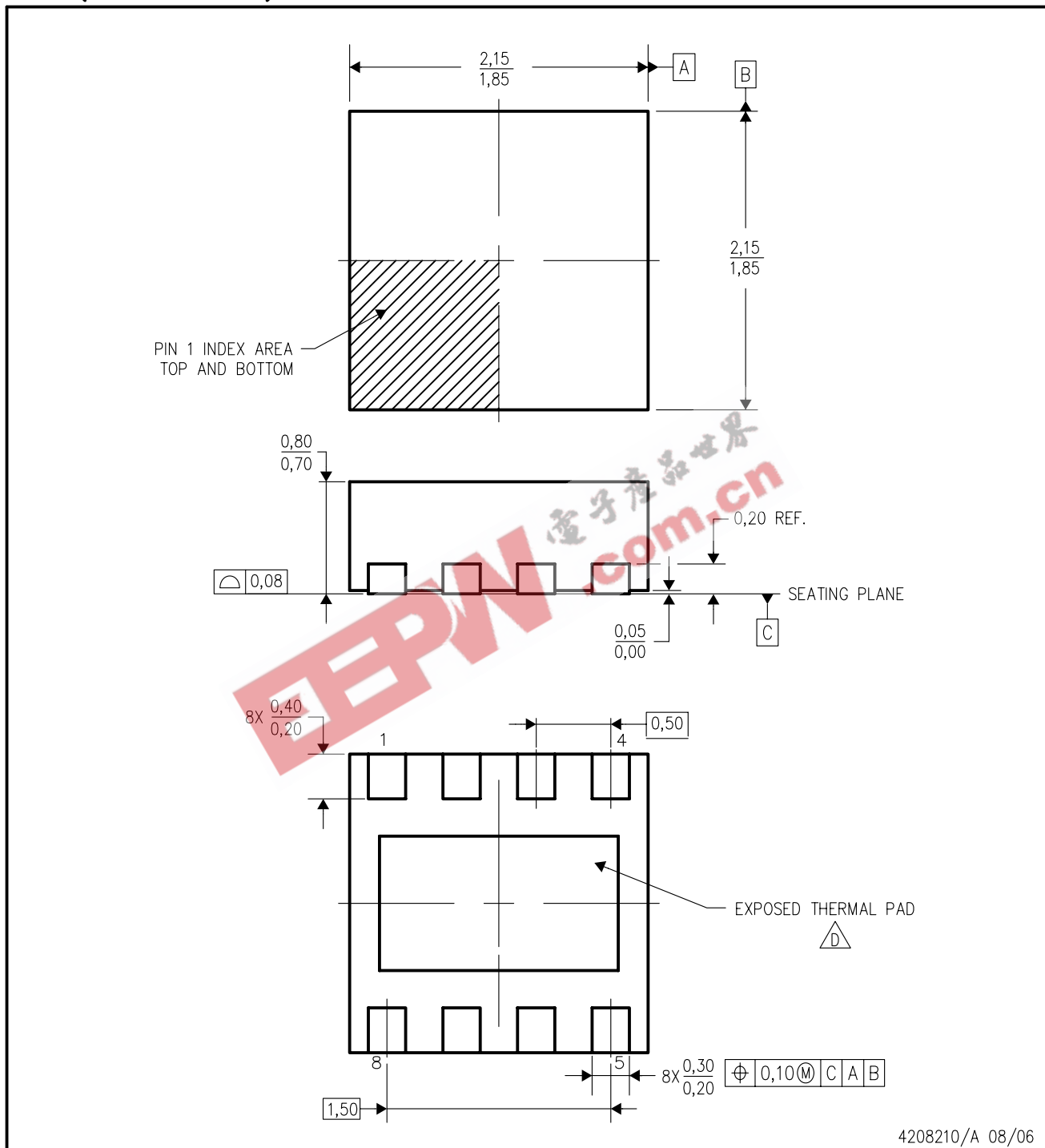

4208210/A 08/06

- NOTES:
- A. All linear dimensions are in millimeters. Dimensioning and tolerancing per ASME Y14.5M-1994.
 - B. This drawing is subject to change without notice.
 - C. Quad Flatpack, No-Leads (QFN) package configuration.
 -  The package thermal pad must be soldered to the board for thermal and mechanical performance. See the Product Data Sheet for details regarding the exposed thermal pad dimensions.
 - E. Falls within JEDEC MO-229.

IMPORTANT NOTICE

Texas Instruments Incorporated and its subsidiaries (TI) reserve the right to make corrections, modifications, enhancements, improvements, and other changes to its products and services at any time and to discontinue any product or service without notice. Customers should obtain the latest relevant information before placing orders and should verify that such information is current and complete. All products are sold subject to TI's terms and conditions of sale supplied at the time of order acknowledgment.

TI warrants performance of its hardware products to the specifications applicable at the time of sale in accordance with TI's standard warranty. Testing and other quality control techniques are used to the extent TI deems necessary to support this warranty. Except where mandated by government requirements, testing of all parameters of each product is not necessarily performed.

TI assumes no liability for applications assistance or customer product design. Customers are responsible for their products and applications using TI components. To minimize the risks associated with customer products and applications, customers should provide adequate design and operating safeguards.

TI does not warrant or represent that any license, either express or implied, is granted under any TI patent right, copyright, mask work right, or other TI intellectual property right relating to any combination, machine, or process in which TI products or services are used. Information published by TI regarding third-party products or services does not constitute a license from TI to use such products or services or a warranty or endorsement thereof. Use of such information may require a license from a third party under the patents or other intellectual property of the third party, or a license from TI under the patents or other intellectual property of TI.

Reproduction of TI information in TI data books or data sheets is permissible only if reproduction is without alteration and is accompanied by all associated warranties, conditions, limitations, and notices. Reproduction of this information with alteration is an unfair and deceptive business practice. TI is not responsible or liable for such altered documentation. Information of third parties may be subject to additional restrictions.

Resale of TI products or services with statements different from or beyond the parameters stated by TI for that product or service voids all express and any implied warranties for the associated TI product or service and is an unfair and deceptive business practice. TI is not responsible or liable for any such statements.

TI products are not authorized for use in safety-critical applications (such as life support) where a failure of the TI product would reasonably be expected to cause severe personal injury or death, unless officers of the parties have executed an agreement specifically governing such use. Buyers represent that they have all necessary expertise in the safety and regulatory ramifications of their applications, and acknowledge and agree that they are solely responsible for all legal, regulatory and safety-related requirements concerning their products and any use of TI products in such safety-critical applications, notwithstanding any applications-related information or support that may be provided by TI. Further, Buyers must fully indemnify TI and its representatives against any damages arising out of the use of TI products in such safety-critical applications.

TI products are neither designed nor intended for use in military/aerospace applications or environments unless the TI products are specifically designated by TI as military-grade or "enhanced plastic." Only products designated by TI as military-grade meet military specifications. Buyers acknowledge and agree that any such use of TI products which TI has not designated as military-grade is solely at the Buyer's risk, and that they are solely responsible for compliance with all legal and regulatory requirements in connection with such use.

TI products are neither designed nor intended for use in automotive applications or environments unless the specific TI products are designated by TI as compliant with ISO/TS 16949 requirements. Buyers acknowledge and agree that, if they use any non-designated products in automotive applications, TI will not be responsible for any failure to meet such requirements.

Following are URLs where you can obtain information on other Texas Instruments products and application solutions:

| Products | | Applications | |
|-----------------------|--|---------------------|--|
| Amplifiers | amplifier.ti.com | Audio | www.ti.com/audio |
| Data Converters | dataconverter.ti.com | Automotive | www.ti.com/automotive |
| DSP | dsp.ti.com | Broadband | www.ti.com/broadband |
| Interface | interface.ti.com | Digital Control | www.ti.com/digitalcontrol |
| Logic | logic.ti.com | Military | www.ti.com/military |
| Power Mgmt | power.ti.com | Optical Networking | www.ti.com/opticalnetwork |
| Microcontrollers | microcontroller.ti.com | Security | www.ti.com/security |
| RFID | www.ti-rfid.com | Telephony | www.ti.com/telephony |
| Low Power Wireless | www.ti.com/lpw | Video & Imaging | www.ti.com/video |
| | | Wireless | www.ti.com/wireless |