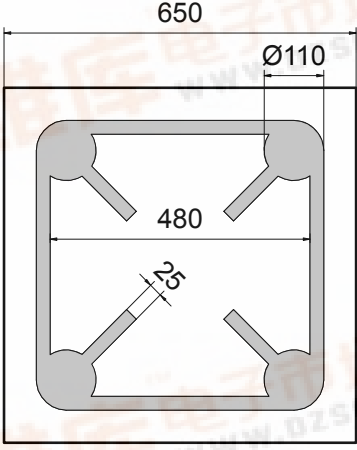

Radiation	Type	Technology	Electrodes
Infrared	DDH	AlGaAs/AlGaAs	P (anode) up

 <p style="text-align: center;">LED-07</p>	typ. dimensions (µm)	
	<u>typ. thickness</u> 160 (+70/-30) µm <u>anode</u> gold alloy, 1.5 µm <u>cathode</u> gold alloy, 0.5 µm dotted, 25% covered	

Optical and Electrical Characteristics

T_{amb} = 25°C, unless otherwise specified

Parameter	Test conditions	Symbol	Min	Typ	Max	Unit
Forward voltage	I _F = 20 mA	V _F		1.3	1.6	V
Forward voltage ³	I _F = 300 mA	V _F		1.6		V
Reverse voltage	I _R = 100 µA	V _R	5			V
Radiant power ¹	I _F = 20 mA	Φ _e	2.8	3.7		mW
Radiant power ²	I _F = 20 mA	Φ _e		7.0		mW
Radiant power ³	I _F = 300 mA	Φ _e		50		mW
Radiant intensity ¹	I _F = 20 mA	I _e	0.75	1.0		mW/sr
Radiant intensity ³	I _F = 300 mA	I _e		13.5		mW/sr
Peak wavelength	I _F = 20 mA	λ _p	860	870	880	nm
Spectral bandwidth at 50%	I _F = 20 mA	Δλ _{0.5}		45		nm
Switching time	I _F = 20 mA	t _r , t _f		10/25		ns

¹Measured on bare chip on TO-18 header

²Measured on epoxy covered chip on TO-18 header

³Measured on bare chip on TO-18 header and heat sink, 10s current flow (information only)

Labeling

Type	Lot N°	Φ _e (typ) [mW]	V _F (typ) [V]	Quantity
ELC-870-12				

Packing: Chips on adhesive film with wire-bond side on top

Note: All measurements carried out with *EPIGAP* equipment

This datasheet has been downloaded from:

www.EEworld.com.cn

Free Download

Daily Updated Database

100% Free Datasheet Search Site

100% Free IC Replacement Search Site

Convenient Electronic Dictionary

Fast Search System

www.EEworld.com.cn