

# SAW Bandpass Filter 250701B - Preliminary

## 1. Features

- IF bandpass filter
- High attenuation
- Single-ended operation
- DIP Package
- Maximum Storage Temperature Range : -40°C ~ 85°C
- Electrostatics Sensitive Device (ESD)

## 2. Package Dimension

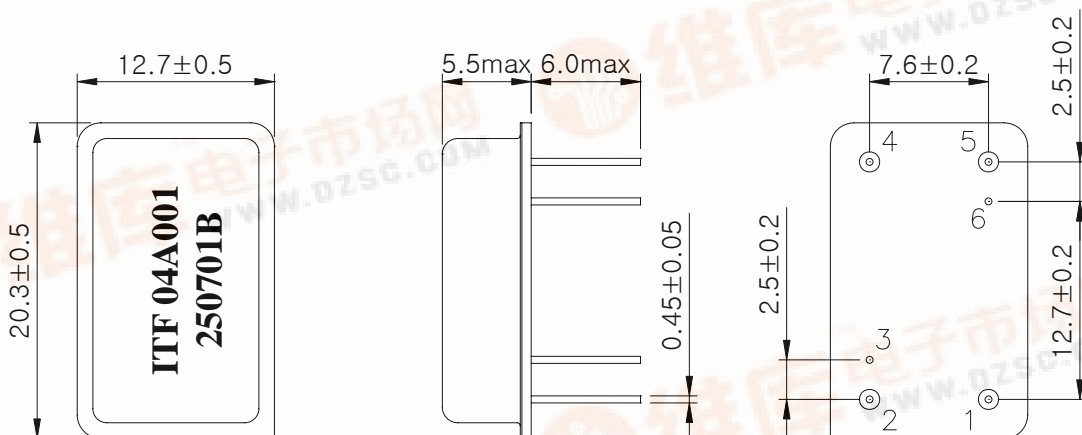

Package : D2012

Dimensions shown are nominal in millimeters

Base : Fe(SPCC), Au plating over Ni plated

Cap : Cu & Cr Alloy, Ni Plated

Termination : Kovar, Au Plated

Pin Configuration	
1	Input
5	Output
2, 4	Ground
3, 6	Case ground

	<b>ITF Co., Ltd.</b> 102-901, Bucheon Technopark 364, Samjeong-Dong, Ojeong-Gu, Bucheon-City, Gyeonggi-Do, Korea 421-809	Part No.	250701B	
		Rev. Date	2004-03-10	
		Rev.	DS4023-CS01	1/5

## SAW Bandpass Filter 250701B - Preliminary

### 3. Specifications

Fo = 140.0 MHz

Terminating source impedance : 50Ω and matching network

Terminating load impedance : 50Ω and matching network

		Minimum	Typical	Maximum
Center Frequency	MHz	139.75	140.0	140.25
Insertion Loss	dB	-	22.0	25.0
1dB Bandwidth	MHz	-	6.98	-
3dB Bandwidth	MHz	7.0	7.3	-
40dB Bandwidth	MHz	-	8.7	9.0
Amplitude Ripple (Fo +/- 3.0 MHz)	dB	-	0.5	1.0
Group Delay Variation (Fo +/- 3.0 MHz)	nsec	-	100	200
Absolute Delay	usec	-	2.93	-
Ultimate Rejection	dB	50	55	-
Temperature Coefficient of Frequency	ppm/°C	-	-23	-

#### Notes :

- 1) All specifications are based on the matching schematic shown below
- 2) All specifications are measured by Agilent Network analyzer and full 2 port calibration at room temperature
- 3) All attenuation measurements are measured relative to insertion loss

 Integrated Technology Future	<b>ITF Co., Ltd.</b> 102-901, Bucheon Technopark 364, Samjeong-Dong, Ojeong-Gu, Bucheon-City, Gyeonggi-Do, Korea 421-809	Part No.	250701B	
		Rev. Date	2004-03-10	
		Rev.	DS4023-CS01	2/5

## SAW Bandpass Filter 250701B - Preliminary

### 4. Matching Schematic

( Actual matching values may vary due to PCB layout and parasitics )

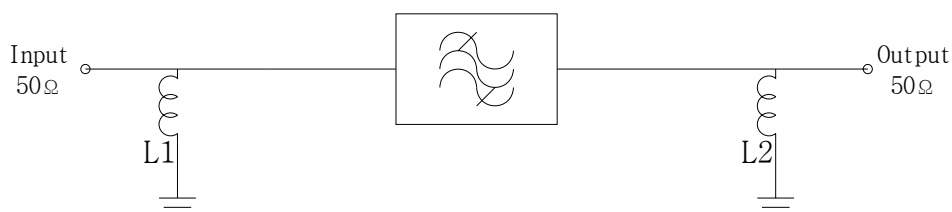

L1 = 27 nH,      L2 = 33 nH

### 5. Marking Configuration

ITF<sup>1)</sup>04A001<sup>2)</sup>  
250701B<sup>3)</sup>

- 1) Manufacturer name
- 2) Lot Number
- 3) Part Number

	<b>ITF Co., Ltd.</b> 102-901, Bucheon Technopark 364, Samjeong-Dong, Ojeong-Gu, Bucheon-City, Gyeonggi-Do, Korea 421-809	Part No.	250701B	
		Rev. Date	2004-03-10	
		Rev.	DS4023-CS01	3/5

# SAW Bandpass Filter 250701B - Preliminary



## 6. Typical Performance ( at +25°C )

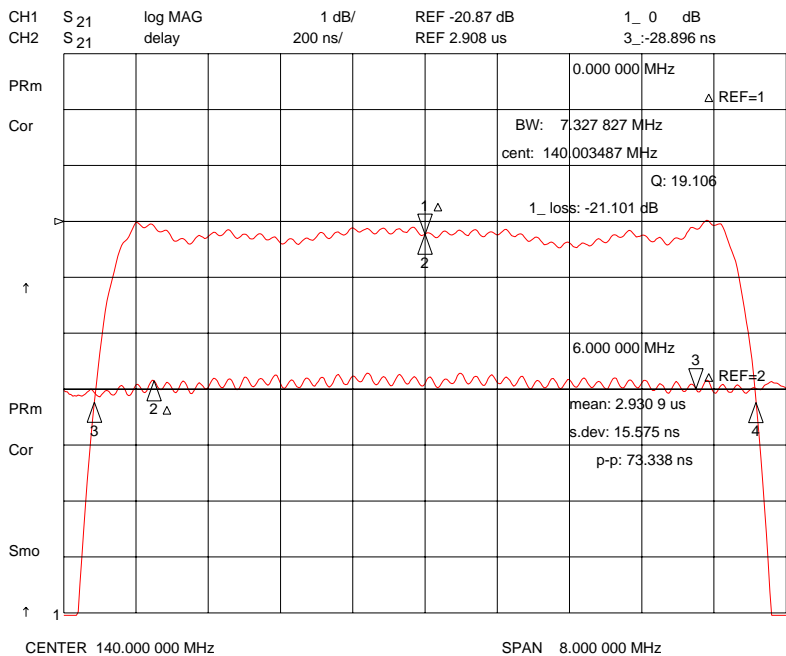
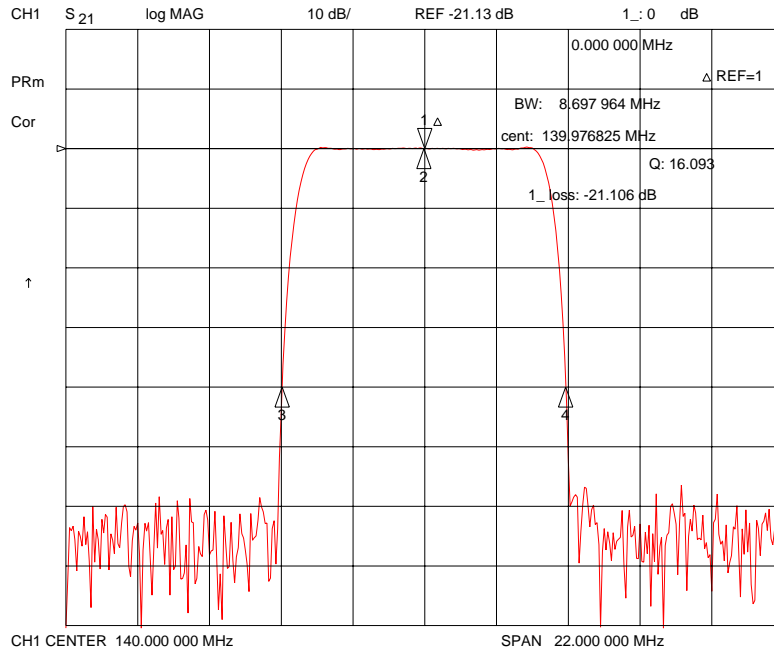

**ITF Co., Ltd.**  
 102-901, Bucheon Technopark 364,  
 Samjeong-Dong, Ojeong-Gu, Bucheon-City,  
 Gyeonggi-Do, Korea 421-809

Part No.	250701B	
Rev. Date	2004-03-10	
Rev.	DS4023-CS01	4/5

# SAW Bandpass Filter 250701B - Preliminary

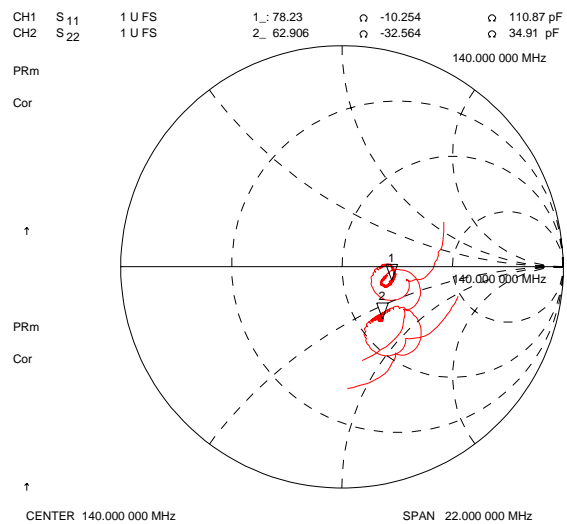
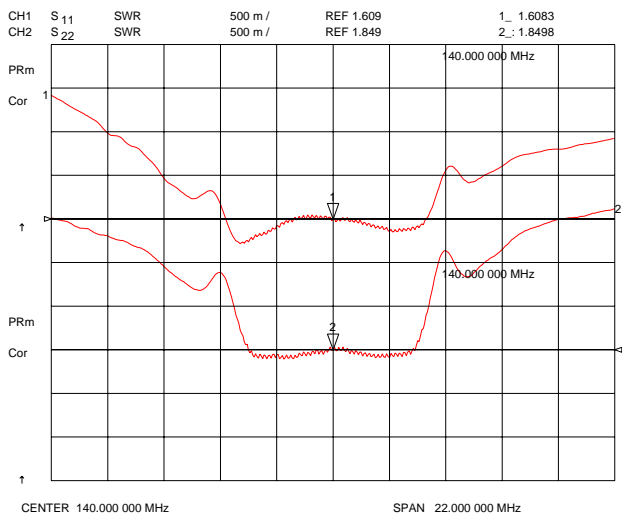
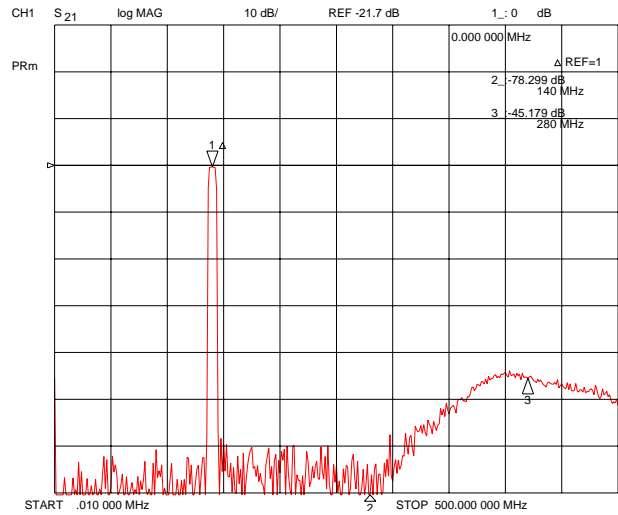
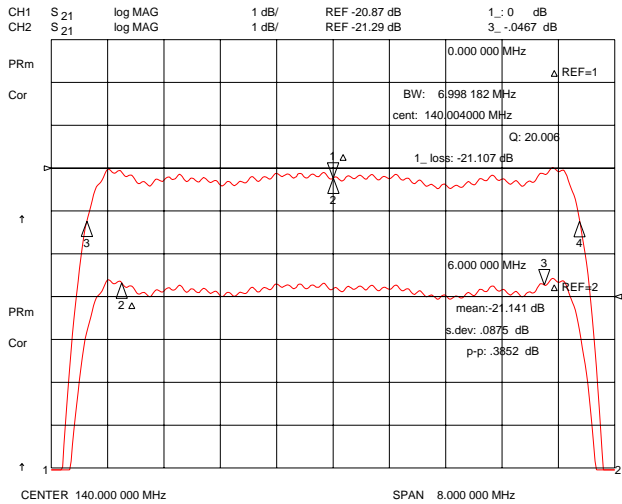

**ITF Co., Ltd.**  
 102-901, Bucheon Technopark 364,  
 Samjeong-Dong, Ojeong-Gu, Bucheon-City,  
 Gyeonggi-Do, Korea 421-809

Part No.	250701B	
Rev. Date	2004-03-10	
Rev.	DS4023-CS01	5/5