

Model 2142

Insulated Miniature Banana Jack

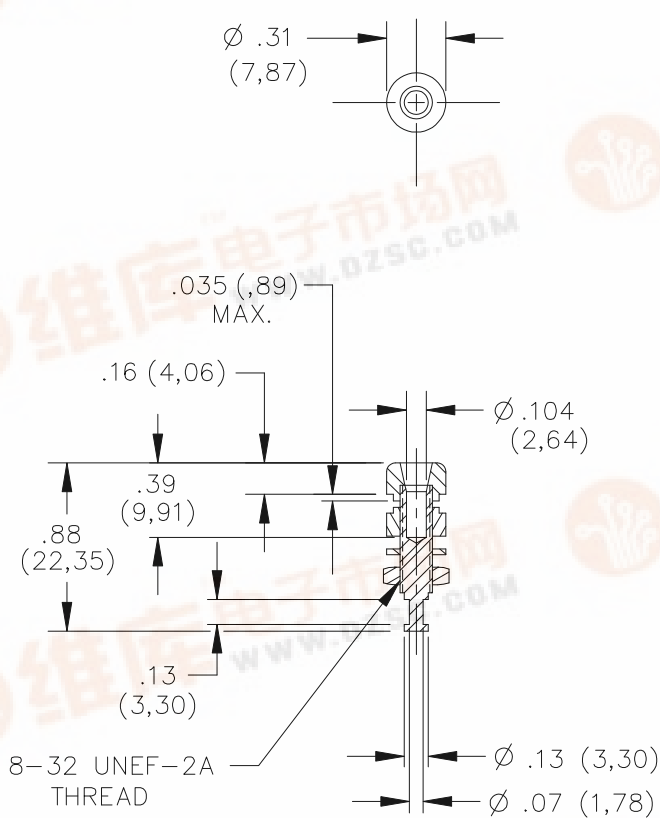

PANEL CUTOUT

MODEL NO.	COLORS AVAILABLE
2142-0	BLACK
2142-2	RED
2142-3	ORANGE
2142-4	YELLOW
2142-5	GREEN
2142-6	BLUE
2142-9	WHITE

FEATURES:

- Accepts miniature banana plugs.
- Mounts in panels up to .250" thick.

MATERIAL:

Banana Jack Insulation – Polycarbonate. Color: Black
 Panel Insulator – Polycarbonate. Color: Black
 Lockwasher, #8 Internal Tooth – Steel
 Hex Nut, #8-32 – Brass
 Banana Jack Body – Brass

Finish:

Lockwasher #8 – Nickel plated
 Hex Nut - Nickel plated.
 Banana Jack Body - Gold plated.

RATINGS:

Operating Temperature: +115°C (+239°F) Max.
 Current: 5 Amperes.

ORDERING INFORMATION: Model 2142-*

*=Color Code – See Tabulation Block
 Sold in packages of 10.

All dimensions are in inches. Tolerances (except noted): .xx = $\pm .02$ " (.51 mm), .xxx = $\pm .005$ " (.127 mm).
 All specifications are to the latest revisions. Specifications are subject to change without notice.
 Registered trademarks are the property of their respective companies.

USA: Sales: 800-490-2361
 Europe: 31-(0) 40 2675 150

Fax: 425-446-5844
 International: 425-446-5500

Technical Support: technicalsupport@pomonatest.com
 Where to Buy: www.pomonaelectronics.com

