

DATA SHEET

查询"NE55410GR-T3-AZ"供应商

NEC

LDMOS FIELD EFFECT TRANSISTOR NE55410GR

N-CHANNEL SILICON POWER LDMOS FET FOR 2 W + 10 W VHF to L-BAND SINGLE-END POWER AMPLIFIER

DESCRIPTION

The NE55410GR is an N-channel enhancement-mode LDMOS FET designed for driver 0.1 to 2.6 GHz PA, such as, cellular base station amplifier, analog/digital TV-transmitters, and the other PA's. This product has two different FET's on one die manufactured using our NEWMOS technology (our WSi gate lateral MOS FET), and its nitride surface passivation and quadruple layer aluminum silicon metalization offer a high degree of reliability.

FEATURES

- Two different FET's (Q1 : P_{out} = 2 W, Q2 : P_{out} = 10 W) in one package
 - Over 25 dB gain available by connecting two FET's in series
 - : G_L (Q1) = 13.5 dB TYP. (V_{DS} = 28 V, I_{Dset} (Q1) = 20 mA, f = 2 140 MHz)
 - : G_L (Q2) = 11.0 dB TYP. (V_{DS} = 28 V, I_{Dset} (Q2) = 100 mA, f = 2 140 MHz)
 - High 1 dB compression output power : P_O (1 dB) (Q1) = 35.4 dBm TYP. (V_{DS} = 28 V, I_{Dset} (Q1) = 20 mA, f = 2 140 MHz)
 - : P_O (1 dB) (Q2) = 40.4 dBm TYP. (V_{DS} = 28 V, I_{Dset} (Q2) = 100 mA, f = 2 140 MHz)
 - High drain efficiency
 - : η_d (Q1) = 52% TYP. (V_{DS} = 28 V, I_{Dset} (Q1) = 20 mA, f = 2 140 MHz)
 - : η_d (Q2) = 46% TYP. (V_{DS} = 28 V, I_{Dset} (Q2) = 100 mA, f = 2 140 MHz)
 - Low intermodulation distortion : IM₃ (Q1) = -40 dBc TYP. (V_{DS} = 28 V, I_{Dset} (Q1+Q2) = 120 mA, f = 2 132.5/2 147.5 MHz, P_{out} = 33 dBm (2 tones))
- <R>
- Single Supply (V_{DS} : 3 V < V_{DS} ≤ 32 V)
 - Excellent Thermal Stability
 - Surface mount type and Super low cost plastic package : 16-pin plastic HTSSOP
 - Integrated ESD protection
 - Excellent stability against HCl (Hot Carrier Injection)

APPLICATION

- <R>
- Digital cellular base station PA : W-CDMA/GSM/D-AMPS/N-CDMA/PCS etc.
 - UHF-band TV transmitter PA

Caution Observe precautions when handling because these devices are sensitive to electrostatic discharge.

The information in this document is subject to change without notice. Before using this document, please confirm that this is the latest version.
Not all products and/or types are available in every country. Please check with an NEC Electronics sales representative for availability and additional information.

ORDERING INFORMATION

Part Number	Order Number	Package	Marking	Supplying Form
NE55410GR	NE55410GR-T3-AZ	16-pin plastic HTSSOP (Pb-Free) ^{Note}	55410	<ul style="list-style-type: none"> Embossed tape 12 mm wide Pin 1 and 8 indicates pull-out direction of tape Qty 1 kpcs/reel

Note With regards to terminal solder (the solder contains lead) plated products (conventionally plated), contact your nearby sales office.

Remark To order evaluation samples, contact your nearby sales office.
Part number for sample order: NE55410GR

PIN CONNECTIONS AND INTERNAL BLOCK DIAGRAM

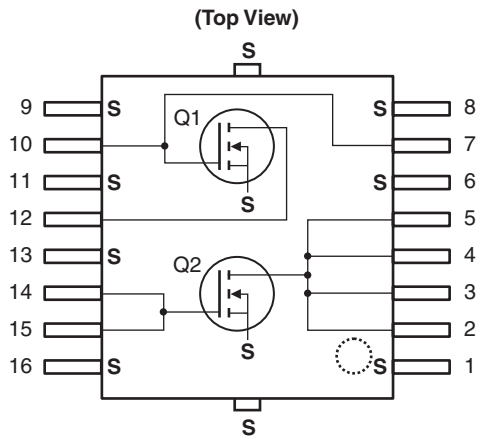

Pin No.	Pin Name	Pin No.	Pin Name
1	Source	9	Source
2	Drain (Q2)	10	Gate (Q1)
3	Drain (Q2)	11	Source
4	Drain (Q2)	12	Drain (Q1)
5	Drain (Q2)	13	Source
6	Source	14	Gate (Q2)
7	Gate (Q1)	15	Gate (Q2)
8	Source	16	Source

Remark All the terminals of a Q2 connected to a circuit. Backside : Source (S)

ABSOLUTE MAXIMUM RATINGS (T_A = +25°C, unless otherwise specified)

Parameter	Symbol	Test Conditions	Ratings	Unit
Drain to Source Voltage	V _{DS}		65	V
Gate to Source Voltage	V _{GS}		±7	V
Drain Current (Q1)	I _{D (Q1)}		0.25	A
Drain Current (Q2)	I _{D (Q2)}		1.0	A
Total Device Dissipation (T _{case} = 25°C)	P _{tot}		40	W
Input Power (Q1)	P _{in (Q1)}	f = 2.14 GHz, V _{DS} = 28 V	0.3	W
Input Power (Q2)	P _{in (Q2)}	f = 2.14 GHz, V _{DS} = 28 V	1.5	W
Channel Temperature	T _{ch}		150	°C
Storage Temperature	T _{stg}		-65 to +150	°C

THERMAL RESISTANCE (T_A = +25°C)

Parameter	Symbol	Test Conditions	MIN.	TYP.	MAX.	Unit
Channel to Case Resistance	R _{th (ch-c)}		–	2.5	3.0	°C/W

RECOMMENDED OPERATING CONDITIONS (T_A = +25°C)

Parameter	Symbol	MIN.	TYP.	MAX.	Unit
<R> Drain to Source Voltage	V _{DS}	–	28	32	V
Gate to Source Voltage	V _{GS}	2.7	3.3	3.7	V
Input Power (Q1), CW	P _{in (Q1)}	–	15	23	dBm
Input Power (Q2), CW	P _{in (Q2)}	–	20	30	dBm
<R> Average Output Power (Q1), CW ^{Note}	P _{O (ave.) (Q1)}	–	–	24	dBm
<R> Average Output Power (Q2), CW ^{Note}	P _{O (ave.) (Q2)}	–	–	30	dBm

<R> **Note** When mounting on the PWB that our company recommends.

ELECTRICAL CHARACTERISTICS (T_A = +25°C)

Parameter	Symbol	Test Conditions	MIN.	TYP.	MAX.	Unit
Q1						
Gate to Source Leak Current	I _{GSS (Q1)}	V _{GSS} = 5V	–	–	1	μA
Drain to Source Leakage Current	I _{DSS (Q1)}	V _{DSS} = 65 V	–	–	1	mA
Gate Threshold Voltage	V _{th (Q1)}	V _{DS} = 10 V, I _{DS} = 1 mA	2.2	2.8	3.4	V
Transconductance	g _{m (Q1)}	V _{DS} = 28 V, I _{DS} = 20 mA	–	0.09	–	S
Drain to Source Breakdown Voltage	BV _{DSS (Q1)}	I _{DSS} = 10 μA	65	75	–	V
Q2						
Gate to Source Leak Current	I _{GSS (Q2)}	V _{GSS} = 5V	–	–	1	μA
Drain to Source Leakage Current	I _{DSS (Q2)}	V _{DSS} = 65 V	–	–	1	mA
Gate Threshold Voltage	V _{th (Q2)}	V _{DS} = 10 V, I _{DS} = 1 mA	2.0	2.6	3.2	V
Transconductance	g _{m (Q2)}	V _{DS} = 28 V, I _{DS} = 100 mA	–	0.45	–	S
Drain to Source Breakdown Voltage	BV _{DSS (Q2)}	I _{DSS} = 10 μA	65	75	–	V

<R> RF CHARACTERISTICS (T_A = +25°C)

Parameter	Symbol	Test Conditions	MIN.	TYP.	MAX.	Unit
Q1						
Gain 1 dB Compression Output Power	P _{O(1 dB)}	f = 2 140 MHz, V _{DS} = 28 V,	–	35.4	–	dBm
Drain Efficiency	η_d	I _{Dset} = 20 mA	–	52	–	%
Linear Gain	G _L ^{Note1}		12	13.5	–	dB
Q2						
Gain 1 dB Compression Output Power	P _{O(1 dB)}	f = 2 140 MHz, V _{DS} = 28 V,	–	40.4	–	dBm
Drain Efficiency	η_d	I _{Dset} = 100 mA	–	46	–	%
Linear Gain	G _L ^{Note2}		9.5	11	–	dB
Gain 1 dB Compression Output Power	P _{O(1 dB)}	f = 1 840 MHz, V _{DS} = 28 V,	–	40.5	–	dBm
Drain Efficiency	η_d	I _{Dset} = 100 mA	–	49	–	%
Linear Gain	G _L ^{Note2}		–	14	–	dB
Q1 + Q2						
Gain 1 dB Compression Output Power	P _{O(1 dB)}	f = 880 MHz, V _{DS} = 28 V,	–	41.5	–	dBm
Drain Efficiency	η_d	I _{Dset} = 120 mA (Q1 + Q2)	–	55	–	%
Linear Gain	G _L ^{Note3}		–	30	–	dB
Gain 1 dB Compression Output Power	P _{O(1 dB)}	f = 2 140 MHz, V _{DS} = 28 V,	–	40.0	–	dBm
Drain Efficiency	η_d	I _{Dset} = 120 mA (Q1 + Q2)	34	42	–	%
Output Power	P _{out}		39	40	–	dB
Linear Gain	G _L ^{Note4}		24	25	–	dB
3rd Order Intermodulation Distortion	IM ₃	f = 2 132.5/2 147.5 MHz, V _{DS} = 28 V,	–	–40	–	dBc
Drain Efficiency	η_d	2 carrier W-CDMA 3GPP, Test Model1, 64DPCH, 67% Clipping, I _{Dset} = 120 mA (Q1 + Q2), Ave P _{out} = 33 dBm	–	21	–	%

- Notes 1. P_{in} = 15 dBm
- 2. P_{in} = 20 dBm
- 3. P_{in} = 5 dBm
- 4. P_{in} = 10 dBm

TYPICAL CHARACTERISTICS (TA = +25°C, VDS = 28 V, Idset = 120 mA, unless otherwise specified)

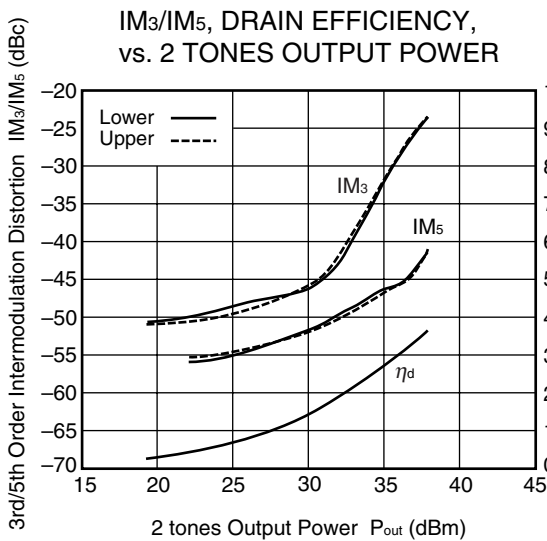
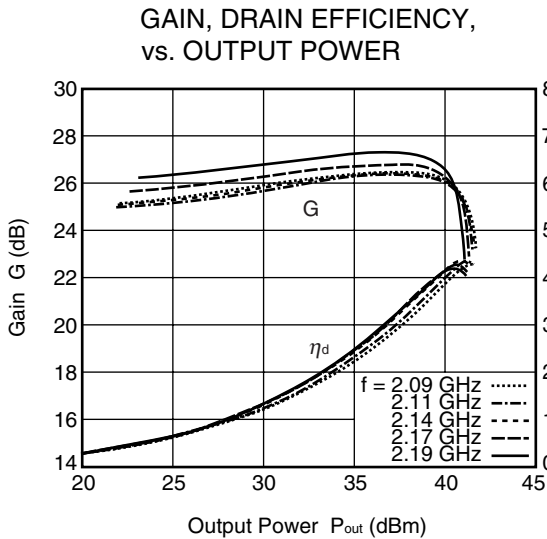
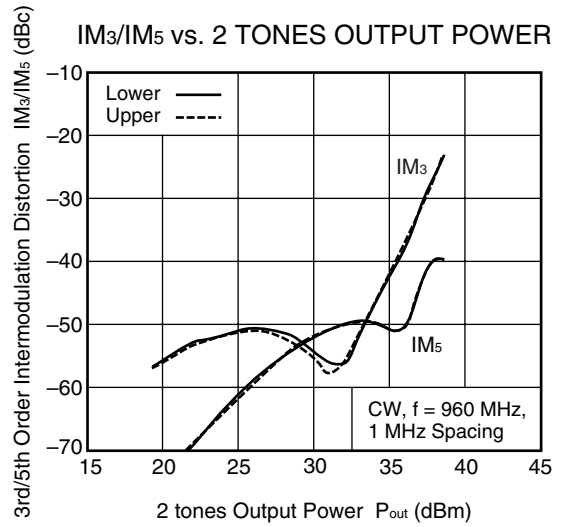
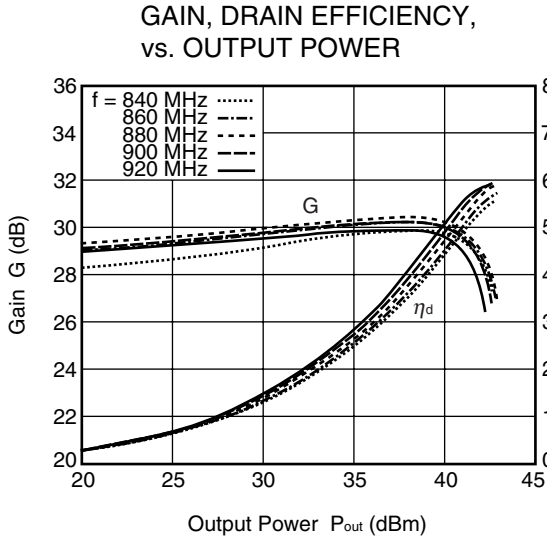

W-CDMA 3GPP, Test Model 1,
 64 DPCH, 67% Clipping,
 Center Frequency 2.14GHz,
 15 MHz spacing

Remark The graphs indicate nominal characteristics.

[查询"NE55410GR-T3-AZ"供应商](#)

<R> **S-PARAMETERS**

S-parameters/Noise parameters are provided on our web site in a form (S2P) that enables direct import to a microwave circuit simulator without keyboard input.

Click here to download S-parameters.

[RF and Microwave] → [Device Parameters]

URL <http://www.ncsd.necel.com/microwave/index.html>

EVALUATION CIRCUIT (f = 840 to 960 MHz, V_{DS} = 28 V, I_{Dset} = 120 mA)

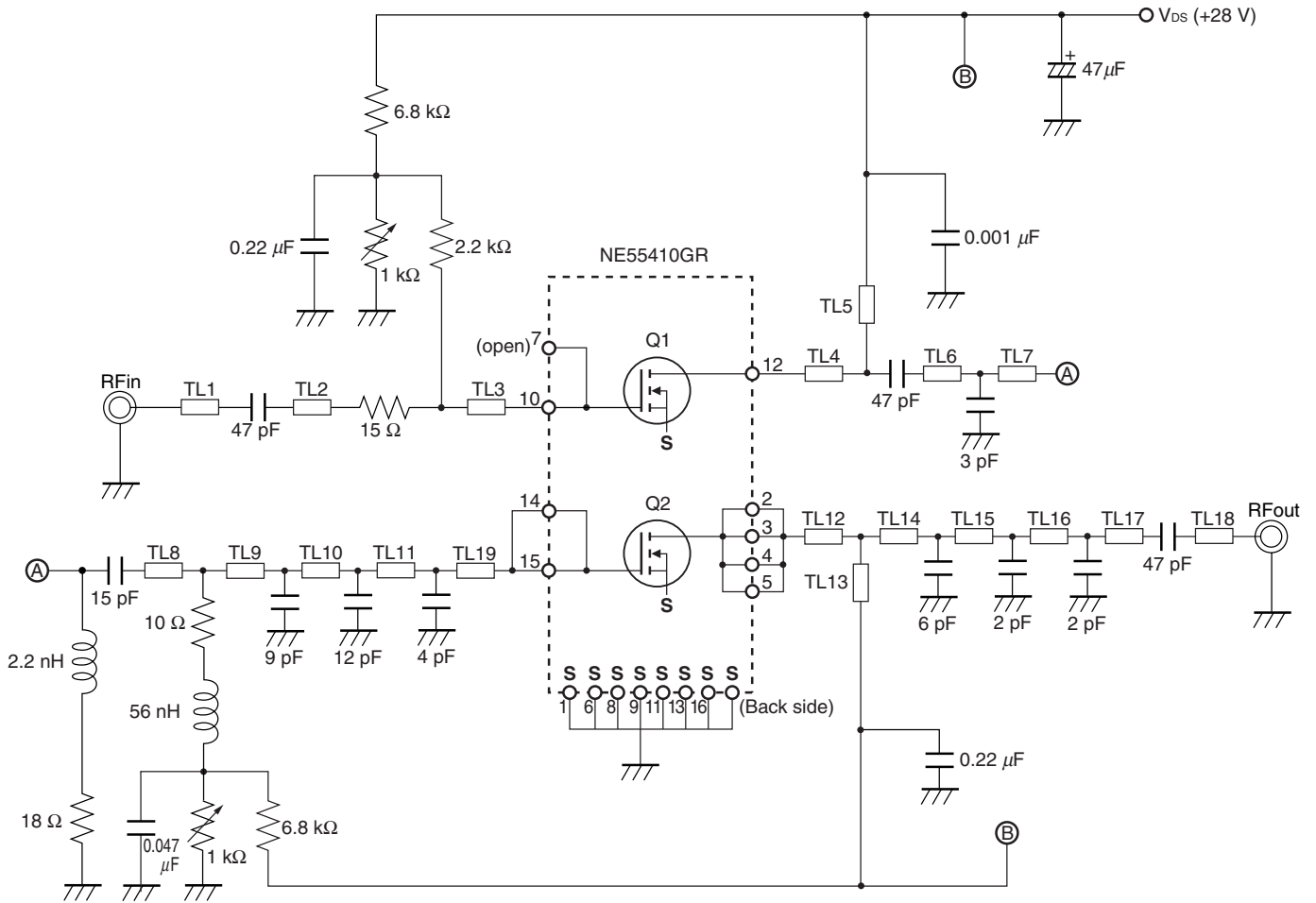

Symbol	Width (mm)	Length (mm)
TL1	1.0	3.0
TL2	4.5	10.0
TL3	0.5	16.0
TL4	0.5	5.0
TL5	1.0	48.0
TL6	1.0	4.0
TL7	1.0	3.0
TL8	1.0	6.0
TL9	1.0	3.0
TL10	1.0	4.0

Symbol	Width (mm)	Length (mm)
TL11	1.0	3.0
TL12	1.0	5.0
TL13	0.8	48.0
TL14	1.0	6.5
TL15	1.0	10.5
TL16	1.0	9.5
TL17	1.0	10.0
TL18	1.0	6.0
TL19	1.0	3.0

The application circuits and their parameters are for reference only and are not intended for use in actual design-ins.

EVALUATION CIRCUIT (f = 840 to 960 MHz, V_{DS} = 28 V, I_{Dset} = 120 mA)

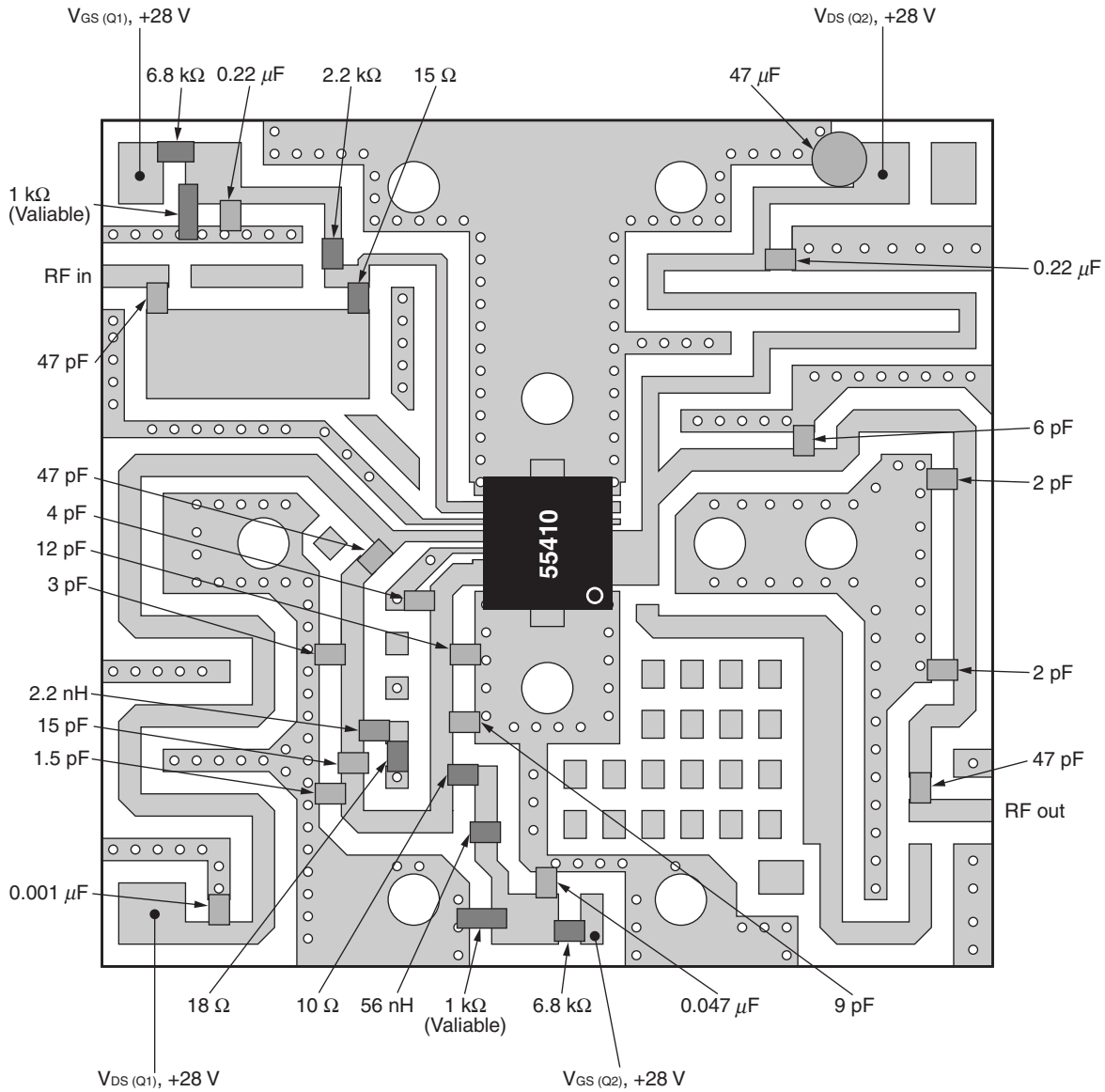

EVALUATION CIRCUIT (f = 2 090 to 2 190 MHz, V_{DS} = 28 V, I_{Dset} = 120 mA)

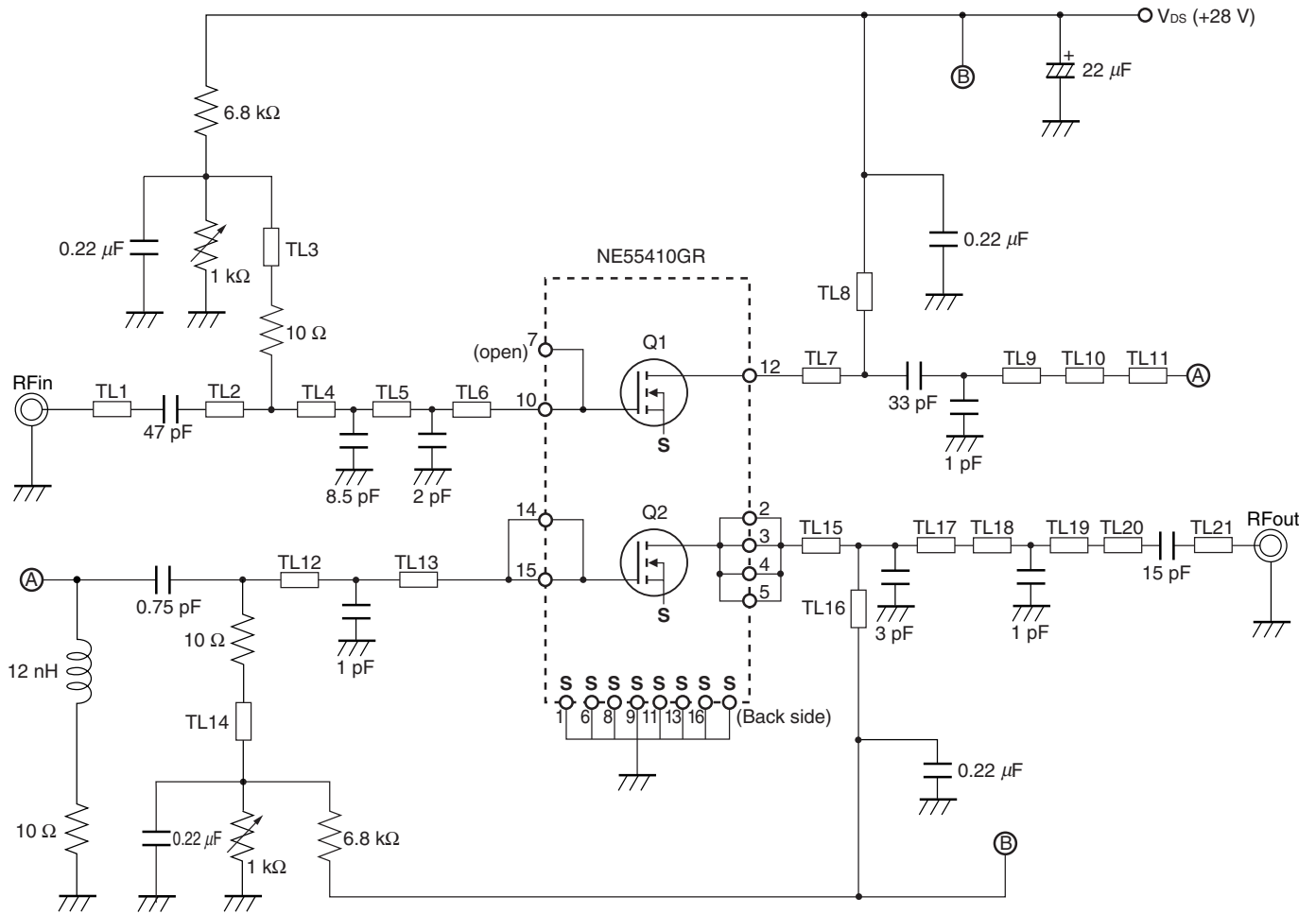

Symbol	Width (mm)	Length (mm)
TL1	1.0	17.0
TL2	1.0	4.0
TL3	1.0	24.5
TL4	1.0	2.5
TL5	1.0	3.0
TL6	0.5	2.5
TL7	0.5	4.5
TL8	1.0	25.5
TL9	1.0	2.5
TL10	4.5	4.5
TL11	1.0	3.5

Symbol	Width (mm)	Length (mm)
TL12	1.0	4.0
TL13	1.0	4.5
TL14	1.0	25.0
TL15	2.5	2.5
TL16	1.0	27.0
TL17	1.0	2.0
TL18	5.0	4.0
TL19	5.0	2.0
TL20	1.0	12.5
TL21	1.0	5.5

The application circuits and their parameters are for reference only and are not intended for use in actual design-ins.

<R> **EVALUATION CIRCUIT (f = 2 090 to 2 190 MHz, V_{DS} = 28 V, I_{Dset} = 120 mA)**

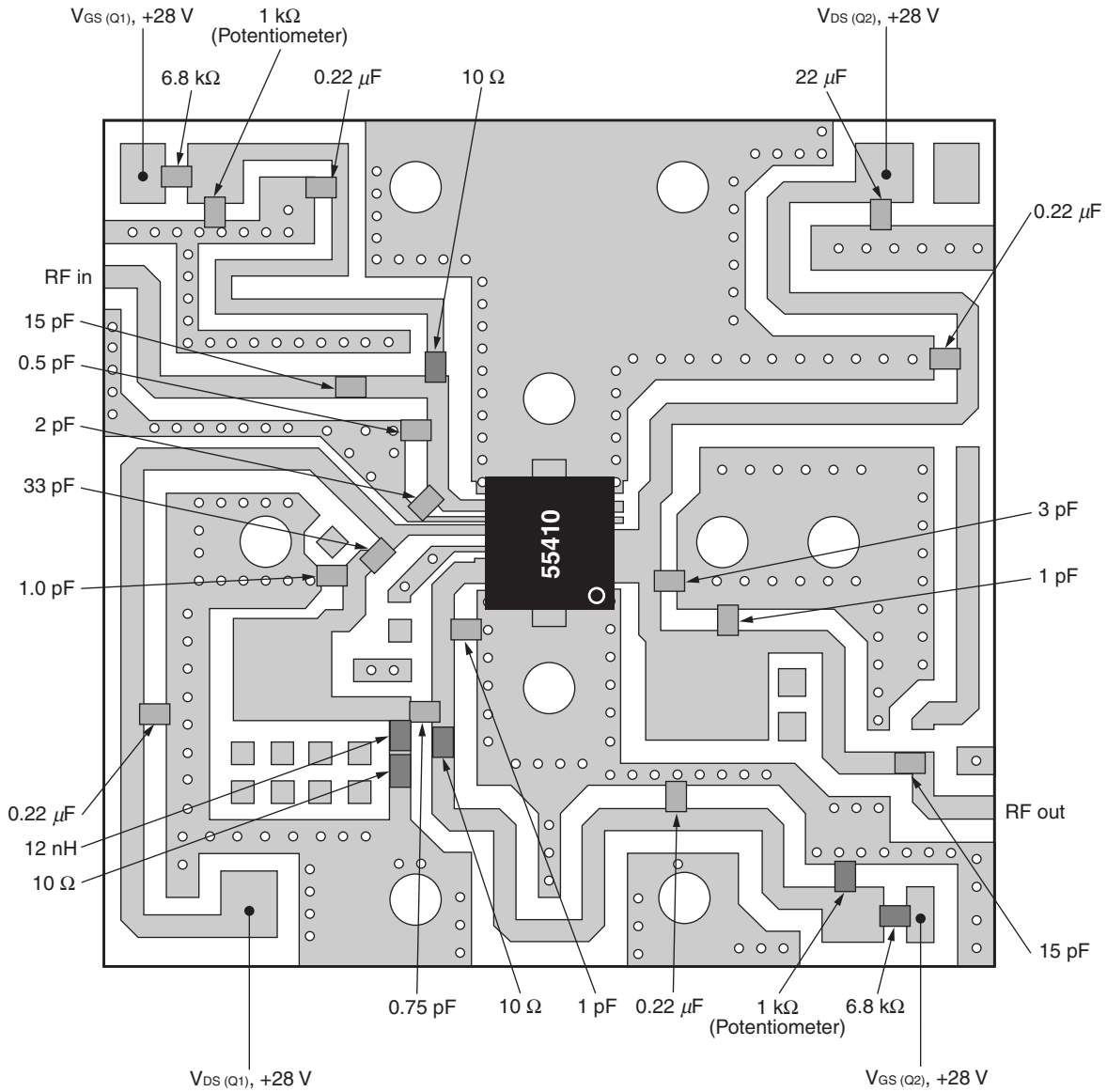

RECOMMENDED SOLDERING CONDITIONS

This product should be soldered and mounted under the following recommended conditions. For soldering methods and conditions other than those recommended below, contact your nearby sales office.

Soldering Method	Soldering Conditions	Condition Symbol
Infrared Reflow	Peak temperature (package surface temperature) : 260°C or below Time at peak temperature : 10 seconds or less Time at temperature of 220°C or higher : 60 seconds or less Preheating time at 120 to 180°C : 120±30 seconds Maximum number of reflow processes : 3 times Maximum chlorine content of rosin flux (% mass) : 0.2%(Wt.) or below	IR260
Wave Soldering	Peak temperature (molten solder temperature) : 260°C or below Time at peak temperature : 10 seconds or less Preheating temperature (package surface temperature) : 120°C or below Maximum number of flow processes : 1 time Maximum chlorine content of rosin flux (% mass) : 0.2%(Wt.) or below	WS260
Partial Heating	Peak temperature (terminal temperature) : 350°C or below Soldering time (per side of device) : 3 seconds or less Maximum chlorine content of rosin flux (% mass) : 0.2%(Wt.) or below	HS350

Caution Do not use different soldering methods together (except for partial heating).

- **The information in this document is current as of January, 2007. The information is subject to change without notice. For actual design-in, refer to the latest publications of NEC Electronics data sheets or data books, etc., for the most up-to-date specifications of NEC Electronics products. Not all products and/or types are available in every country. Please check with an NEC Electronics sales representative for availability and additional information.**
- No part of this document may be copied or reproduced in any form or by any means without the prior written consent of NEC Electronics. NEC Electronics assumes no responsibility for any errors that may appear in this document.
- NEC Electronics does not assume any liability for infringement of patents, copyrights or other intellectual property rights of third parties by or arising from the use of NEC Electronics products listed in this document or any other liability arising from the use of such products. No license, express, implied or otherwise, is granted under any patents, copyrights or other intellectual property rights of NEC Electronics or others.
- Descriptions of circuits, software and other related information in this document are provided for illustrative purposes in semiconductor product operation and application examples. The incorporation of these circuits, software and information in the design of a customer's equipment shall be done under the full responsibility of the customer. NEC Electronics assumes no responsibility for any losses incurred by customers or third parties arising from the use of these circuits, software and information.
- While NEC Electronics endeavors to enhance the quality, reliability and safety of NEC Electronics products, customers agree and acknowledge that the possibility of defects thereof cannot be eliminated entirely. To minimize risks of damage to property or injury (including death) to persons arising from defects in NEC Electronics products, customers must incorporate sufficient safety measures in their design, such as redundancy, fire-containment and anti-failure features.
- NEC Electronics products are classified into the following three quality grades: "Standard", "Special" and "Specific".

The "Specific" quality grade applies only to NEC Electronics products developed based on a customer-designated "quality assurance program" for a specific application. The recommended applications of an NEC Electronics product depend on its quality grade, as indicated below. Customers must check the quality grade of each NEC Electronics product before using it in a particular application.

"Standard": Computers, office equipment, communications equipment, test and measurement equipment, audio and visual equipment, home electronic appliances, machine tools, personal electronic equipment and industrial robots.

"Special": Transportation equipment (automobiles, trains, ships, etc.), traffic control systems, anti-disaster systems, anti-crime systems, safety equipment and medical equipment (not specifically designed for life support).

"Specific": Aircraft, aerospace equipment, submersible repeaters, nuclear reactor control systems, life support systems and medical equipment for life support, etc.

The quality grade of NEC Electronics products is "Standard" unless otherwise expressly specified in NEC Electronics data sheets or data books, etc. If customers wish to use NEC Electronics products in applications not intended by NEC Electronics, they must contact an NEC Electronics sales representative in advance to determine NEC Electronics' willingness to support a given application.

(Note)

- (1) "NEC Electronics" as used in this statement means NEC Electronics Corporation and also includes its majority-owned subsidiaries.
- (2) "NEC Electronics products" means any product developed or manufactured by or for NEC Electronics (as defined above).