

[查询"17559"供应商](#)

Micromotor Driver with Dual 3-Phase and Dual H-Bridge Outputs

The 17559 is a monolithic quad H-Bridge power IC ideal for portable electronic applications containing multiple brushless and brush DC-motors.

The 17559 is designed to drive motors with supplies operating from 0.9 V to 3.5 V, with independent control of each output bridge via parallel 1.8 V to 3.6 V logic-compatible I/O. Each output bridge has its own gate-drive and logic circuitry with built-in shoot-through current protection.

The 17559 has a low total $R_{DS(ON)}$ of 1.7 Ω max @ 25°C for each of the two 3-phase output bridges, and a low total $R_{DS(ON)}$ of 1.3 Ω max @ 25°C for each of the two H-Bridge outputs.

The 17559 can efficiently drive many types of micromotors owing to its low output resistance and high output slew rates.

Features

- Two Separate Three-Phase Motor Drivers
- Two Separate H-Bridge Motor Drivers
- Low-Voltage Detection and Shutdown Circuitry
- Pb-Free Packaging Designated by Suffix Code EP

17559

MICROMOTOR
DRIVER WITH DUAL 3-PHASE
AND DUAL H-BRIDGE OUTPUTS

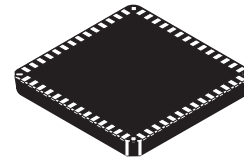

EP SUFFIX (Pb-FREE)
98ARH99036A
56-LEAD QFN

ORDERING INFORMATION

Device	Temperature Range (T _A)	Package
MPC17559EP/R2	-20°C to 65°C	56 QFN

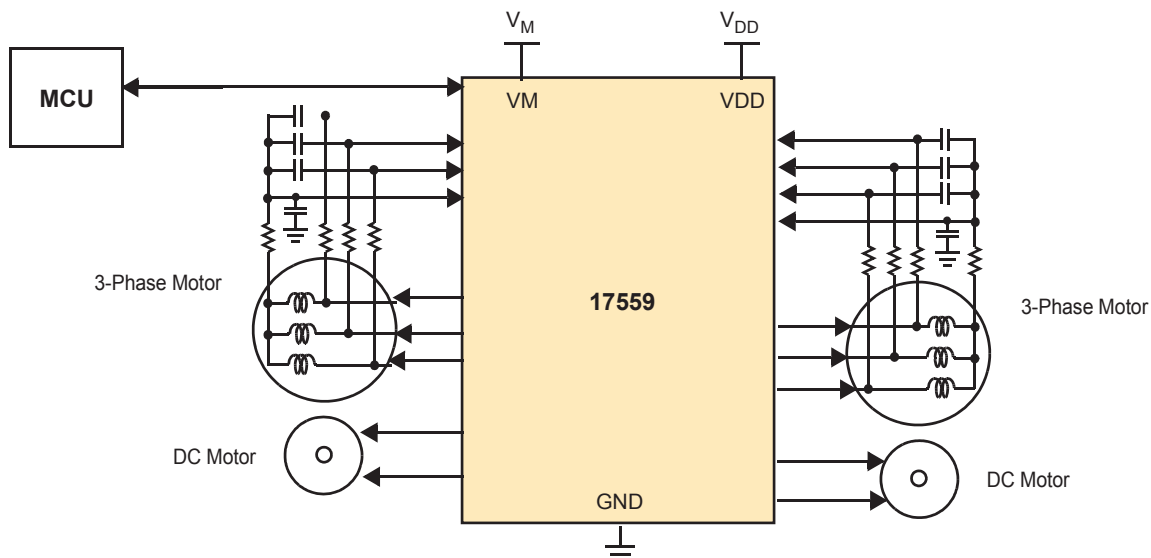

Note Diagram represents one half of the dual application.

Figure 1. 17559 Simplified Application Diagram

* This document contains certain information on a new product. Specifications and information herein are subject to change without notice.

[查询"17559"供应商](#)

INTERNAL BLOCK DIAGRAM

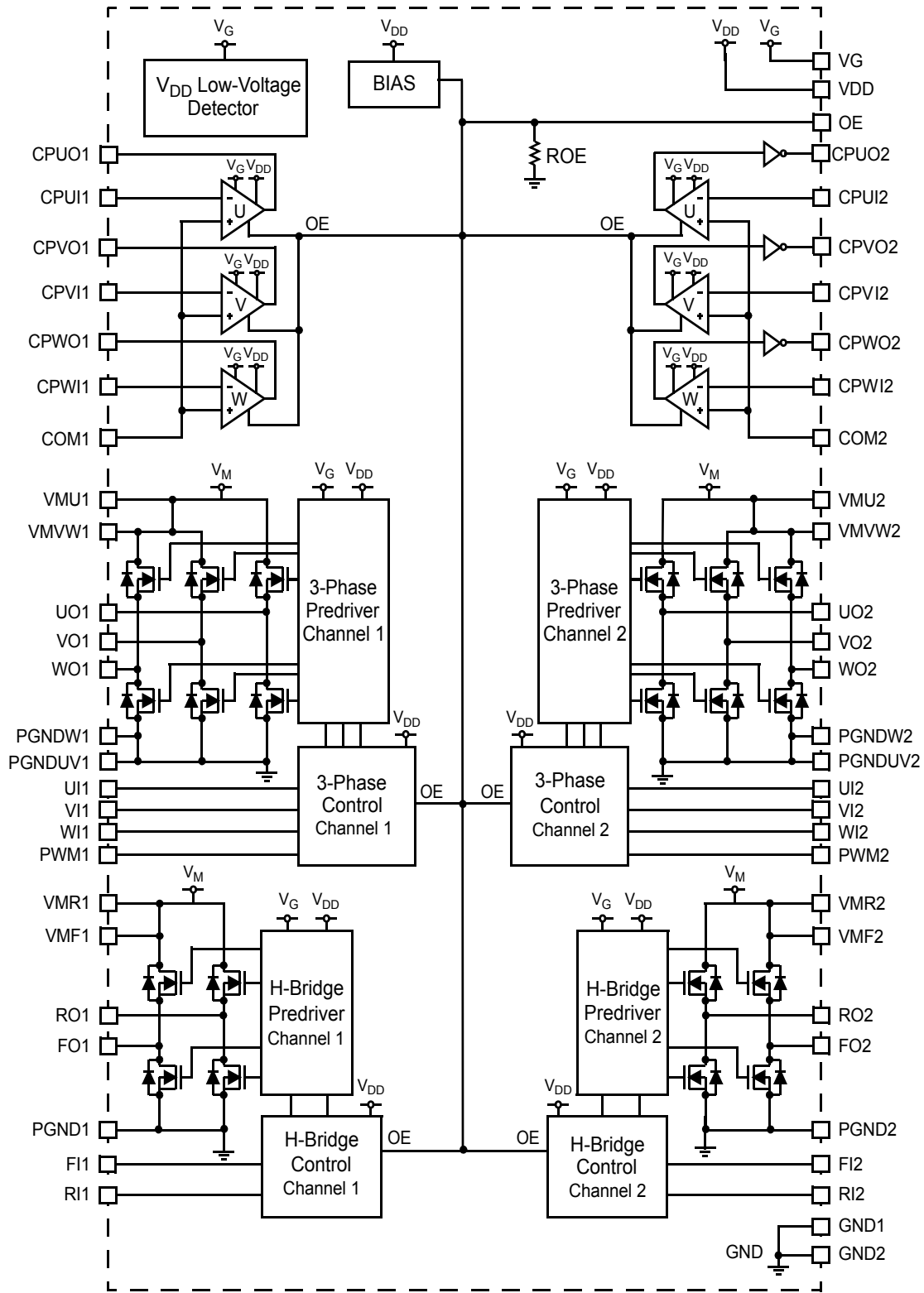

Figure 2. 17559 Simplified Internal Block Diagram

[查询"17559"供应商](#)

TERMINAL CONNECTIONS

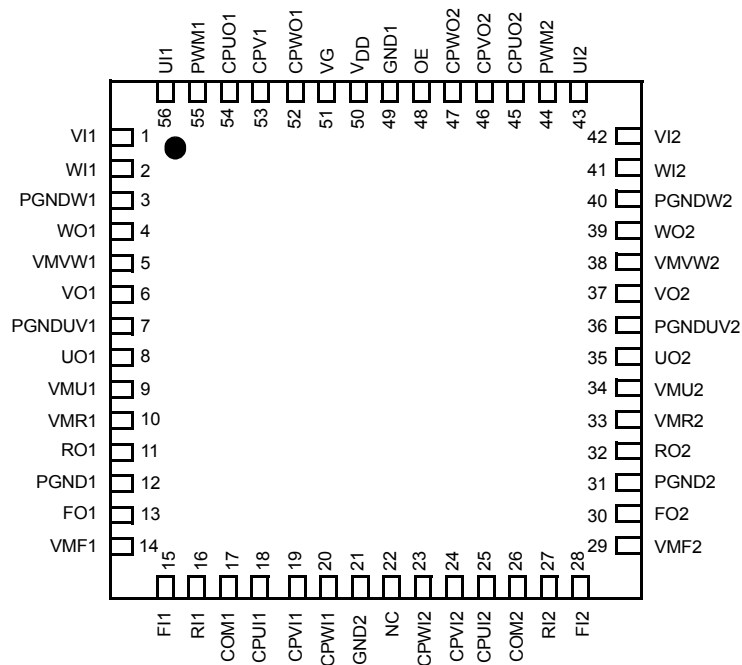

Figure 3. 17559 Terminal Connections

Table 1. 17559 Terminal Definitions

A functional description of each terminal can be found in the Functional Terminal Description section beginning on [page 10](#).

Terminal Number	Terminal Name	Terminal Function	Formal Name	Definition
1	VI1	Input	Three-Phase Input VI1	Three-phase driver channel 1 V input terminal.
2	WI1	Input	Three-Phase Input WI1	Three-phase driver channel 1 W input terminal.
3	PGNDW1	Ground	Power Ground w1	Three-phase driver channel 1 W phase power ground terminal.
4	WO1	Output	Three-Phase Output WO1	Three-phase driver channel 1 W output terminal.
5	VMVW1	Power	Motor Driver Power Supply vw1	Three-phase driver channel 1 VW phase power supply terminal.
6	VO1	Output	Three-Phase Output VO1	Three-phase driver channel 1 phase output terminal.
7	PGNDUV1	Ground	Power Ground uv1	Three-phase driver channel 1 UV phase power ground terminal.
8	UO1	Output	Three-Phase Output UO1	Three-phase driver channel 1 U phase output terminal.
9	VMU1	Power	Motor Driver Power Supply u1	Three-phase driver channel 1 U phase power supply terminal.
10	VMR1	Power	Motor Driver Power Supply R2	H-Bridge driver channel 1 power supply terminal R.
11	RO1	Output	H-Bridge Output RO1	H-Bridge driver channel 1 reverse output terminal.
12	PGND1	Ground	Power Ground 1	H-Bridge driver channel 1 power ground terminal.
13	FO1	Output	H-Bridge Output FO1	H-Bridge driver channel 1 forward output terminal.
14	VMF1	Power	Motor Driver Power Supply F1	H-Bridge driver channel 1 power supply terminal F.
15	FI1	Input	Logic Input Control FI1	H-Bridge driver channel 1 forward input terminal.
16	RI1	Input	Logic Input Control RI1	H-Bridge driver channel 1 reverse input terminal.

[查询"17559"供应商](#)**Table 1. 17559 Terminal Definitions (continued)**

A functional description of each terminal can be found in the Functional Terminal Description section beginning on [page 10](#).

Terminal Number	Terminal Name	Terminal Function	Formal Name	Definition
17	COM1	Input	Forward Input UVW1	Comparator channel 1 UVW forward input terminal.
18	CPU1	Input	Reverse Input UI1	Comparator channel 1 U reverse input terminal.
19	CPV1	Input	Reverse Input VI1	Comparator channel 1 V reverse input terminal.
20	CPW1	Input	Reverse Input WI1	Comparator channel 1 W reverse input terminal.
21	GND2	Ground	Ground 2	Control circuit ground terminal 2.
22	NC		No Connect	This terminal is not used.
23	CPW12	Input	Reverse Input WI2	Comparator channel 2 W reverse input terminal.
24	CPV12	Input	Reverse Input VI2	Comparator channel 2 V reverse input terminal.
25	CPU12	Input	Reverse Input UI2	Comparator channel 2 U reverse input terminal.
26	COM2	Input	Forward Input UVW2	Comparator channel 2 UVW forward input terminal.
27	RI2	Input	Logic Input Control RI2	H-Bridge driver channel 2 reverse input terminal.
28	FI2	Input	Logic Input Control FI2	H-Bridge driver channel 2 forward input terminal.
29	VMF2	Power	Motor Driver Power Supply F2	H-Bridge driver channel 2 power supply terminal F.
30	FO2	Output	H-Bridge Output FO2	H-Bridge driver channel 2 forward output terminal.
31	PGND2	Ground	Power Ground 2	H-Bridge driver channel 2 power ground terminal.
32	RO2	Output	H-Bridge Output RO2	H-Bridge driver channel 2 reverse output terminal.
33	VMR2	Power	Motor Driver Power Supply R2	H-Bridge driver channel 2 power supply terminal R.
34	VMu2	Power	Motor Driver Power Supply u2	Three-phase driver channel 2 U phase power supply terminal.
35	UO2	Output	Three-Phase Output UO2	Three-phase driver channel 2 U phase output terminal.
36	PGNDu2	Ground	Power Ground u2	Three-phase driver channel 2 UV phase power ground terminal.
37	VO2	Output	Three-Phase Output VO2	Three-phase driver channel 2 V phase output terminal.
38	VMw2	Power	Motor Driver Power Supply vw2	Three-phase driver channel 2 VW phase power supply terminal.
39	WO2	Output	Three-Phase Output WO2	Three-phase driver channel 2 W phase output terminal.
40	PGNDw2	Ground	Power Ground w2	Three-phase driver channel 2 W phase power ground terminal.
41	WI2	Input	Three-Phase Input WI2	Three-phase driver channel 2 W input terminal.
42	VI2	Input	Three-Phase Input VI2	Three-phase driver channel 2 V input terminal.
43	UI2	Input	Three-Phase Input UI2	Three-phase driver channel 2 U input terminal.
44	PWM2	Input	PWM Input 2	Three-phase driver channel 2 PWI input terminal.
45	CPUO2	Output	Comparator Output UO2	Comparator channel 2 U output terminal.
46	CPVO2	Output	Comparator Output VO2	Comparator channel 2 V output terminal.
47	CPWO2	Output	Comparator Output WO2	Comparator channel 2 W output terminal.
48	OE	Output	Output Enable	Output enable input terminal.
49	GND1	Ground	Ground 1	Control circuit ground terminal.
50	V _{DD}	Power	Logic Supply	Control circuit power supply terminal.
51	VG		Gate Boost Voltage	Gate drive boost voltage.
52	CPWO1	Output	Comparator Output WO1	Comparator channel 1 W output terminal.
53	CPVO1	Output	Comparator Output VO1	Comparator channel 1 V output terminal.
54	CPUO1	Output	Comparator Output UO1	Comparator channel 1 U output terminal.

17559

Table 1. 17559 Terminal Definitions (continued)

查询"17559"供应商

A functional description of each terminal can be found in the Functional Terminal Description section beginning on [page 10](#).

Terminal Number	Terminal Name	Terminal Function	Formal Name	Definition
55	PWM1	Input	PWM Input 1	Three-phase driver channel 1 PWM input terminal.
56	UI1	Input	Three-Phase Input UI1	Three-phase driver channel 1 U input terminal.

[查询"17559"供应商](#)

ELECTRICAL CHARACTERISTICS

MAXIMUM RATINGS

Table 2. Maximum Ratings

All voltages are with respect to ground unless otherwise noted. Exceeding these ratings may cause a malfunction or permanent damage to the device.

Ratings	Symbol	Value	Unit
ELECTRICAL RATINGS			
Motor Supply Voltage ⁽¹⁾	V_M	-0.5 to 5.0	V
Logic Supply Voltage	V_{DD}	-0.5 to 4.0	V
Gate Drive Boost Voltage	V_G	$V_{DD}-0.5$ to 11	V
Logic Signal Input Voltage ⁽²⁾	V_{IL}	-0.5 to $V_{DD}+0.5$	V
Analog Signal Input Voltage ⁽³⁾	V_{IA}	-0.5 to $V_M+0.5$	V
Driver Output Current ⁽⁴⁾			mA
DC	I_O	300	
Peak ⁽⁵⁾	I_{OPK}	600	
ESD Voltage			V
Human Body Model ⁽⁶⁾	V_{ESD1}	±1000	
Machine Model ⁽⁷⁾	V_{ESD2}	±200	
Control Circuit Output Current ⁽⁸⁾	I_{OV}	10	mA
Power Dissipation ($T_A = 25^\circ\text{C}$)	P_D	1650	mW
THERMAL RATINGS			
Operating Junction Temperature	T_J	150	$^\circ\text{C}$
Operating Ambient Temperature	T_A	-20 to 65	$^\circ\text{C}$
Thermal Resistance	$R_{\theta JA}$	TBD	$^\circ\text{C/W}$
Storage Temperature	T_{STG}	-65 to 150	$^\circ\text{C}$
Terminal Soldering Temperature ⁽⁹⁾	T_{SOLDER}	240	$^\circ\text{C}$

Notes

- VMu1, VMu2, VMvw1, VMvw2, VMF1, VMR1, VMF1, and VMR2 terminals.
- OE, UI1, VI1, WI1, PWM1, UI2, VI2, WI2, PWM2, FI1, RI1, FI2, and RI2 terminals.
- COM1, CPUI1, CPVI1, CPWI1, COM2, CPU12, CPVI2, and CPWI2 terminals.
- FO1, RO1, FO2, RO2, UO1, VO1, WO1, UO2, VO2, and WO2 terminals.
- $T_A = 25^\circ\text{C}$, 0.2 sec cycle, 10 ms max.
- ESD1 testing is performed in accordance with the Human Body Model ($C_{ZAP} = 100 \text{ pF}$, $R_{ZAP} = 1500 \Omega$).
- ESD2 testing is performed in accordance with the Machine Model ($C_{ZAP} = 200 \text{ pF}$, $R_{ZAP} = 0 \Omega$).
- CPUO1, CPVO1, CPWO1, CPUO2, CPVO2, and CPWO2 terminals.
- Soldering temperature limit is for 10 seconds maximum duration. Not designed for immersion soldering. Exceeding these limits may cause malfunction or permanent damage to the device.

[查询"17559"供应商](#)**STATIC ELECTRICAL CHARACTERISTICS****Table 3. Static Electrical Characteristics**

Characteristics noted under conditions $V_M = 1.2\text{ V}$, $V_{DD} = 2.4\text{ V}$, $V_{CRES} = 6.8\text{ V}$, $7.0\text{ V} \leq V_G \leq 18\text{ V}$, $-20^\circ\text{C} \leq T_A \leq 65^\circ\text{C}$, $GND = 0\text{ V}$ unless otherwise noted. Typical values noted reflect the approximate parameter means at $T_A = 25^\circ\text{C}$ under nominal conditions unless otherwise noted.

Characteristic	Symbol	Min	Typ	Max	Unit
POWER					
Motor Supply Voltage ⁽¹⁰⁾	V_M	0.9	1.2	3.5	V
Logic Supply Voltage	V_{DD}	1.8	2.4	3.5	V
Gate Drive Boost Voltage	V_G	$V_M+5.0$	–	9.0	V
Standby Power Supply Current ⁽¹¹⁾					μA
Motor Supply Standby Current	I_{VMSTBY}	–	–	1.0	
Logic Supply Standby Current	$I_{VDDSTBY}$	–	–	1.0	
Gate Drive Boost Voltage	I_{VGSTBY}	–	–	1.0	
No Signal Input Supply Current ⁽¹²⁾					μA
Logic Supply Current	I_{VDDN}	–	30	60	
Gate Drive Boost Voltage	I_{VGN}	–	75	120	
Active Supply Current ⁽¹³⁾					
Logic Supply Current	I_{VDD}	–	50	100	μA
Gate Drive Boost Voltage	I_{VG}	–	0.54	0.65	mA
Driver Output ON Resistance ⁽¹⁴⁾					Ω
Three-Phase Drivers	$R_{DS(ON)3p}$	–	1.30	1.70	
H-Bridge Drivers	$R_{DS(ON)hb}$	–	0.87	1.30	
Low-Voltage Detector Voltage					V
Circuit Disable Voltage	V_{LOon}	0.75	1.07	1.60	
Circuit Enable Voltage	V_{LOoff}	0.75	1.13	1.60	

Notes

10. VMU1, VMU2, VMVW1, VMVW2, VMF1, VMR1, VMF2, and VMR2 terminals.
11. UI1, VI1, WI1, PWM1, UI2, VI2, WI2, PWM2, FI1, RI1, FI2, and RI2 are "L" (low) or "H"
12. UI1, VI1, WI1, PWM1, UI2, VI2, WI2, PWM2, FI1, RI1, FI2, and RI2 are "L" (low) or "H"
13. OE = "H" (high), $f_{PWM} = 176.4\text{ kHz}$, $f_{UVM} = 100\text{ Hz}$, $f_{IN} = 88.2\text{ kHz}$.
14. Summary of top and bottom when $I_O = 100\text{ mA}$.

[查询"17559"供应商](#)

Table 3. Static Electrical Characteristics (continued)

Characteristics noted under conditions $V_M = 1.2\text{ V}$, $V_{DD} = 2.4\text{ V}$, $V_{CRES} = 6.8\text{ V}$, $7.0\text{ V} \leq V_G \leq 18\text{ V}$, $-20^\circ\text{C} \leq T_A \leq 65^\circ\text{C}$, $GND = 0\text{ V}$ unless otherwise noted. Typical values noted reflect the approximate parameter means at $T_A = 25^\circ\text{C}$ under nominal conditions unless otherwise noted.

Characteristic	Symbol	Min	Typ	Max	Unit
CONTROL LOGIC					
Logic Input					
High-Level Input Voltage ⁽¹⁵⁾	V_{IH}	$V_{DD} \times 0.7$	–	–	V
Low-Level Input Voltage ⁽¹⁵⁾	V_{IL}	–	–	$V_{DD} \times 0.3$	V
High-Level Input Current ⁽¹⁶⁾	I_{IH}	–	–	1.0	μA
Low-Level Input Current ⁽¹⁵⁾	I_{IL}	-1.0	–	–	μA
Analog Signal Input Voltage ⁽¹⁷⁾	V_{IA}	0	–	V_M	V
OE Terminal Pull-Down Resistance	R_{OE}	330	660	1000	$\text{k}\Omega$
Comparator Input ⁽¹⁸⁾					
Offset Voltage	V_{OS}	-5.0	–	5.0	mV
Input Current	I_{CP}	-1.0	–	1.0	μA
Comparator Output ⁽¹⁹⁾					
High-Level Output Voltage ⁽²⁰⁾	V_{OH}	$V_{DD} \times 0.85$	–	–	V
Low-Level Output Voltage ⁽²¹⁾	V_{OL}	–	–	$V_{DD} \times 0.15$	V

Notes

15. OE, UI1, VI1, WI1, PWM1, UI2, VI2, WI2, PWM2, FI1, RI1, FI2, and RI2 terminals.
16. UI1, VI1, WI1, PWM1, UI2, VI2, WI2, PWM2, FI1, RI1, FI2, and RI2 terminals.
17. COM1, CPU1, CPV1, CPW1, COM2, CPU2, CPV2, and CPW2 terminals.
18. CPU1, CPV1, CPW1, CPU2, CPV2, and CPW2 terminals.
19. CPUO1, CPVO1, CPWO1, CPUO2, CPVO2, and CPWO2 terminals.
20. $I_{SOURCE} = 500\ \mu\text{A}$.
21. $I_{SINK} = 500\ \mu\text{A}$.

[查询"17559"供应商](#)**DYNAMIC ELECTRICAL CHARACTERISTICS****Table 4. Dynamic Electrical Characteristics**

Characteristics noted under conditions $V_M = 1.2\text{ V}$, $V_{DD} = 2.4\text{ V}$, $V_{C_{RES}} = 6.8\text{ V}$, $7.0\text{ V} \leq V_G \leq 18\text{ V}$, $-40^\circ\text{C} \leq T_A \leq 125^\circ\text{C}$, $GND = 0\text{ V}$ unless otherwise noted. Typical values noted reflect the approximate parameter means at $T_A = 25^\circ\text{C}$ under nominal conditions unless otherwise noted.

Characteristic	Symbol	Min	Typ	Max	Unit
INPUT					
Input Signal Frequency					
PWM1, PWM2	f_{PWM}	–	176.4	–	kHz
UI1, VI1, WI1, UI2, VI2, WI2	f_{UVW}	–	100	–	Hz
FI1, RI1, FI2, RI2	f_{IN}	–	88.2	–	kHz

[查询"17559"供应商](#)

FUNCTIONAL DESCRIPTION

INTRODUCTION

The 17559 is a monolithic dual 3-phase plus dual H-Bridge multiple motor driver IC ideal for portable electronic applications containing two brushless DC motors plus two DC brush motors (or plus one bipolar step motor). The control logic translates the input signals to the gate-driver circuitry while providing cross-conduction suppression.

The drivers are designed to be PWM'ed at high frequencies for efficient and noise-free motor control. The 17559 is designed for portable audio and video applications such as camcorders, but it may be used in any application requiring highly efficient control of micromotors. Authors' Note:

FUNCTIONAL DESCRIPTION

THREE-PHASE DRIVER CHANNEL 1 INPUT (UI1, VI1, AND WI1)

The three-phase driver channel 1 input terminals (UI1, VI1, and WI1) set the driver states (UO1, VO1, and WO1) in accordance with the logic set force defined in [Table 7](#), page 11. Typically these inputs are supplied from an MCU or a digital signal processor (DSP) to provide the phasing of the currents applied to a brushless DC motor.

THREE-PHASE DRIVER CHANNEL 1 OUTPUT (UO1, VO1, AND WO1)

The three-phase driver channel 1 output terminals (UO1, VO1, and WO1) drive a three-phase motor, as well as supply the peak currents with applied ON resistance ($R_{DS(ON)hb}$).

THREE-PHASE DRIVER CHANNEL 1 PHASE POWER GROUND (PGNDW1 AND PGNDUV1)

The three-phase driver channel 1 phase power ground terminals (PGNDw1 and PGNDuv1) are ground terminals for three-phase driver channel 1. PGNDw1 is a ground for W phase driver, and PGNDuv1 is a ground for U and V phase driver. PGNDw1 and PGNDuv1 are physically connected in the IC in order to reduce internal resistance.

THREE-PHASE DRIVER CHANNEL 1 PHASE POWER SUPPLY (VMVW1 AND VMU1)

The three-phase driver channel 1 phase power supply terminals (VMvw1 and VMu1) are power supply terminals for three-phase driver channel 1. VMvw1 is a power supply for V and W phase driver, and VMu1 is a power supply for U phase driver. VMvw1 and VMu1 are physically connected in the IC in order to reduce internal resistance.

THREE-PHASE DRIVER CHANNEL 2 INPUT (UI2, VI2, AND WI2)

The three-phase driver channel 2 input terminals (UI2, VI2, and WI2) set the driver states (UO2, VO2, and WO2) in accordance with the logic set force in [Table 7](#). Typically these inputs are supplied from an MCU or DSP to provide the phasing of the current applied to a brushless DC motor.

THREE-PHASE DRIVER CHANNEL 2 OUTPUT (UO2, VO2, AND WO2)

The three-phase driver channel 2 output terminals (UO2, VO2, and WO2) drive a three-phase motor, as well as supply the peak currents with applied ON resistance ($R_{DS(ON)hb}$).

THREE-PHASE DRIVER CHANNEL 2 PHASE POWER GROUND (PGNDW2 AND PGNDUV2)

The three-phase driver channel 2 phase power ground terminals (PGNDw2 and PGNDuv2) are ground terminals for three-phase driver channel 2. PGNDw2 is a ground for W phase driver, and PGNDuv2 is a ground for U and V phase driver. PGNDw2 and PGNDuv2 are physically connected in the IC in order to reduce internal resistance.

THREE-PHASE DRIVER CHANNEL 2 PHASE POWER SUPPLY (VMVW2 AND VMU2)

The three-phase driver channel 2 phase power supply terminals (VMvw2 and VMu2) are power supply terminals for three-phase driver channel 2. VMvw2 is a power supply for V and W phase driver, and VMu2 is a power supply for U phase driver. VMvw2 and VMu2 are physically connected in the IC in order to reduce internal resistance.

LOGIC INPUT (OE, FI1, RI1, FI2, AND RI2)

These logic input terminals control each H-Bridge output. OE = 1 is an output enable for each H-Bridge control and for each three-phase comparator (refer to [Table 6](#), page 11).

H-BRIDGE OUTPUTS (RO1, FO1, RO2, AND FO2)

These terminals provide connection to the outputs of each internal H-Bridge (see [Figure 1. 17559 Simplified Application Diagram](#), page 1).

POWER SUPPLY (VMR1, VMF1, VMR2, AND VMF2)

These VM terminals carry the main power supply voltage and current into the H-Bridge power section of the 17559. The supply voltage then becomes controlled and/or modulated by the IC as it delivers the power to the loads attached between the output terminals. All VM terminals are connected internally for VMR1 and VMF1, and VMR2 and

[查询"17559"供应商](#)

VMF2, but they must be connected together on the printed circuit board.

SUPPLY VOLTAGE (VDD)

The V_{DD} terminal carries the logic supply voltage and current into the logic sections of the 17559. The V_{DD} has an undervoltage threshold. If the supply voltage drops between the undervoltage threshold, the output power stage switches to a tri-state condition. When the supply voltage returns to a level that is above the threshold, the power stage automatically resumes normal operation according to the established condition of the input terminals.

GROUND (GND1 AND GND2)

The GND1 and GND2 are main ground terminals for internal logic. They are connected internally.

POWER INPUT (PWM)

The pulse width modulation input provides a single input terminal to accomplish PWM modulation of the output pairs in accordance with the states of input conditions described in [Table 7](#).

LOGIC COMMAND REGISTERS

Table 5. Operating Function

OE	Bias Circuit	H Bridge Driver	3 Phase Driver	Comparator
L	Stop	Output "L"	Output "L"	1*
H	Operation	Operation	Operation	Operation

L = Low.
H = High.

*1: CPUO1, CPVO1, CPWO1 Output = L, CPUO2, CPVO2, CPWO2 Output = H.

Table 6. H-Bridge Driver

Input			Output	
OE	FIn	RIn	FOn	ROn
L	X	X	L	L
H	L	L	L	L
H	L	H	L	H
H	H	L	H	L
H	H	H	L	L

L = Low.
H = High.
X = Don't care.
Z = High impedance.

Table 7. Three-Phase Driver

Input				Output		
OE	UIn	VIn	WIn	UOn	VOn	WOn
L	X	X	X	L	L	L
H	L	L	L	L	L	L
H	L	L	H	Z	L	PWM
H	L	H	L	L	PWM	Z

[查询"17559"供应商](#)

Table 7. Three-Phase Driver

H	L	H	H	L	Z	PWM
H	H	L	L	PWM	Z	L
H	H	L	H	PWM	L	Z
H	H	H	L	Z	PWM	L
H	H	H	H	L	L	L

L = Low.

H = High.

X = Don't care.

Z = High impedance.

PWM = Duty pulse same as PWM terminal input.

查询"17559"供应商

TYPICAL APPLICATIONS

INTRODUCTION

Figure 4 shows a typical application for the 17559.

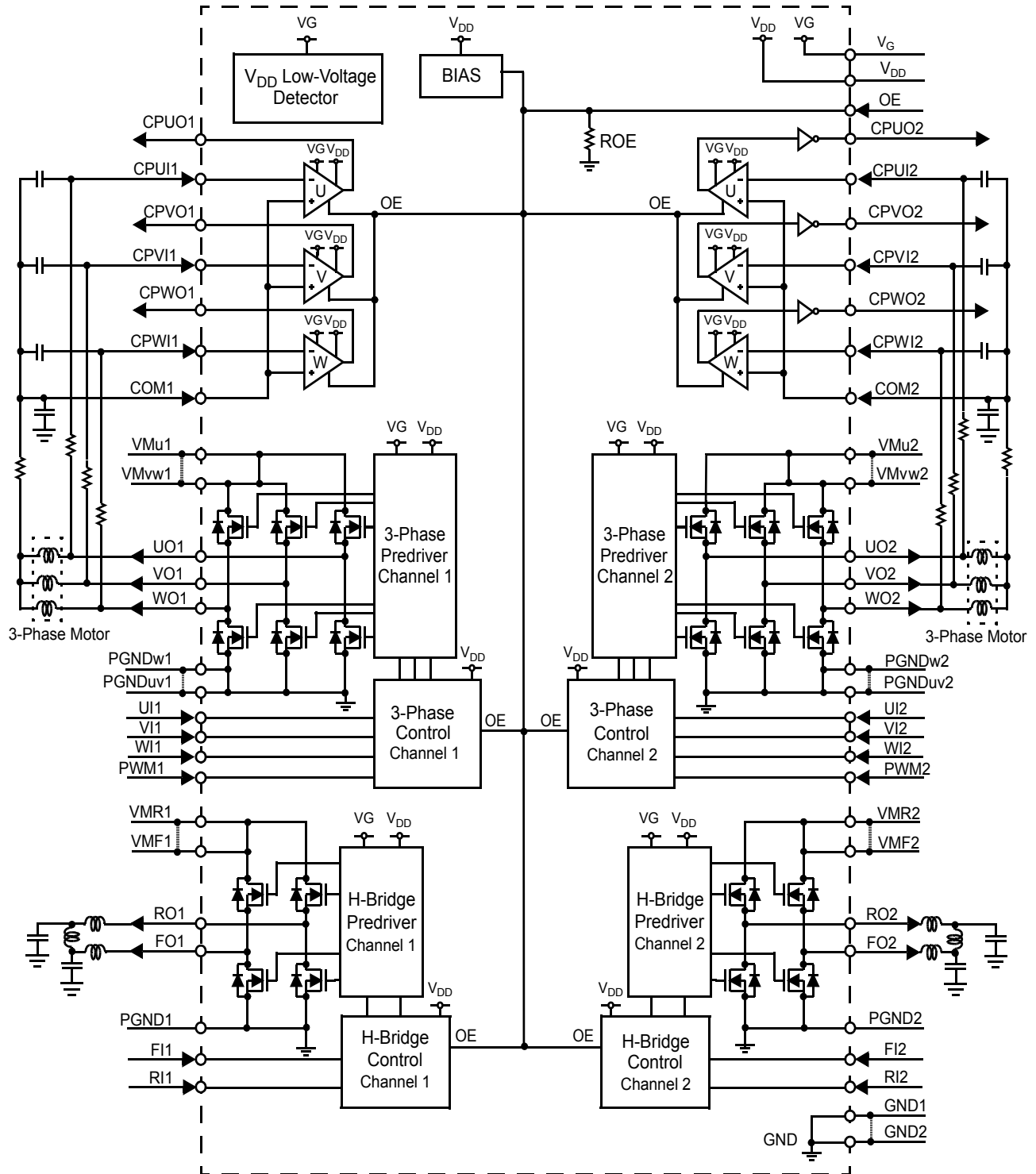

Figure 4. 17559 Typical Application Diagram

[查询"17559"供应商](#)

CEMF SNUBBING TECHNIQUES

Care must be taken to protect the IC from potentially damaging CEMF spikes induced when commutating currents in inductive loads. Typical practice is to provide snubbing of voltage transients by placing a capacitor or zener at the motor supply voltage terminal (VM).

PCB LAYOUT

When designing the printed circuit board (PCB), connect sufficient capacitance between power supply and ground terminals to ensure proper filtering against transients. For all high-current paths, use wide copper traces and the shortest possible distances.

[查询"17559"供应商](#)

PACKAGING

PACKAGE DIMENSIONS

For the most current package revision, visit www.freescale.com and perform a "keyword" search using the 98ARH99036A listed.

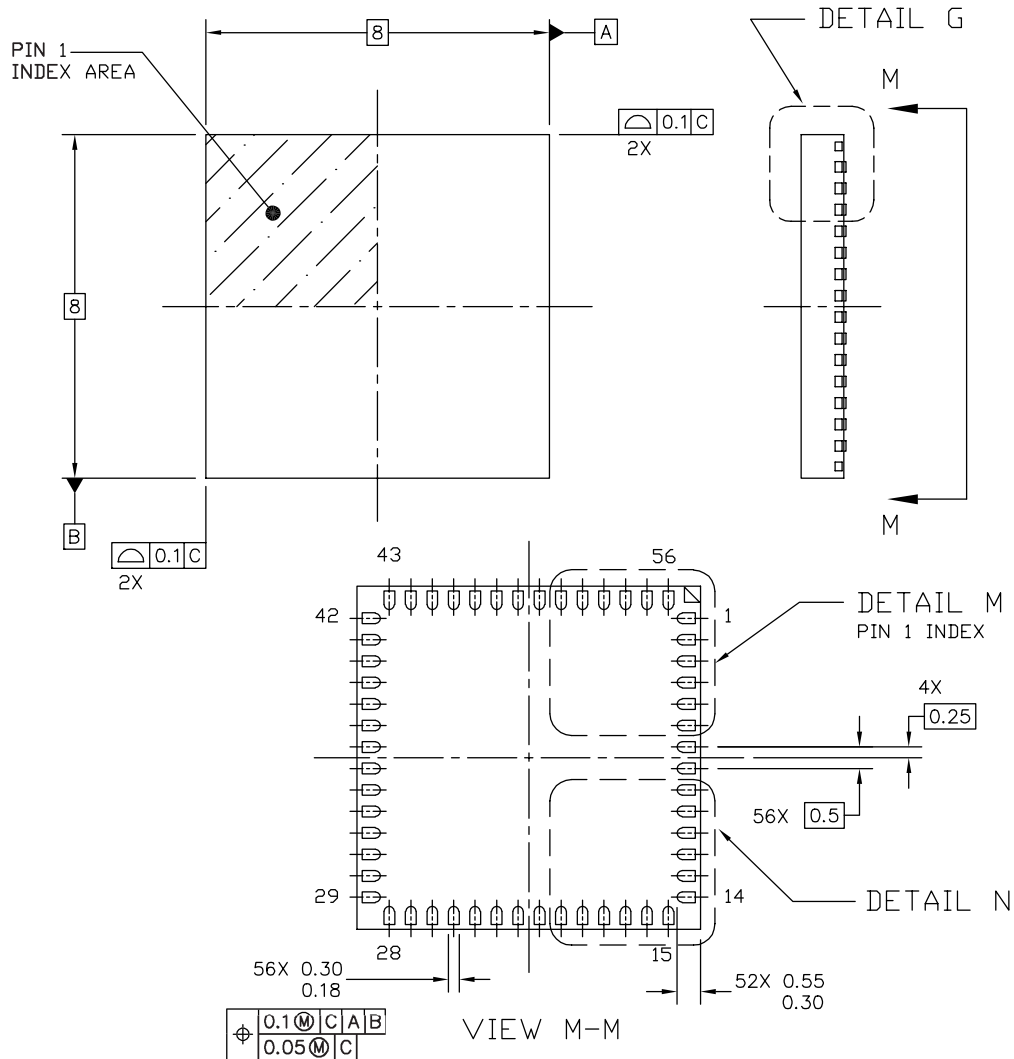

© FREESCALE SEMICONDUCTOR, INC. ALL RIGHTS RESERVED.	MECHANICAL OUTLINE	PRINT VERSION NOT TO SCALE	
TITLE: QUAD FLAT NON-LEADED PACKAGE (QFN) 56 TERMINAL, 0.5 PITCH, (8X8X1)	DOCUMENT NO: 98ARH99036A	REV: B	
	CASE NUMBER: 1312-02	04 JUL 2005	
	STANDARD: NON-JEDEC		

EP SUFFIX
56-LEAD QFN
PLASTIC PACKAGE
98ARH99036A
ISSUE B

[查询"17559"供应商](#)

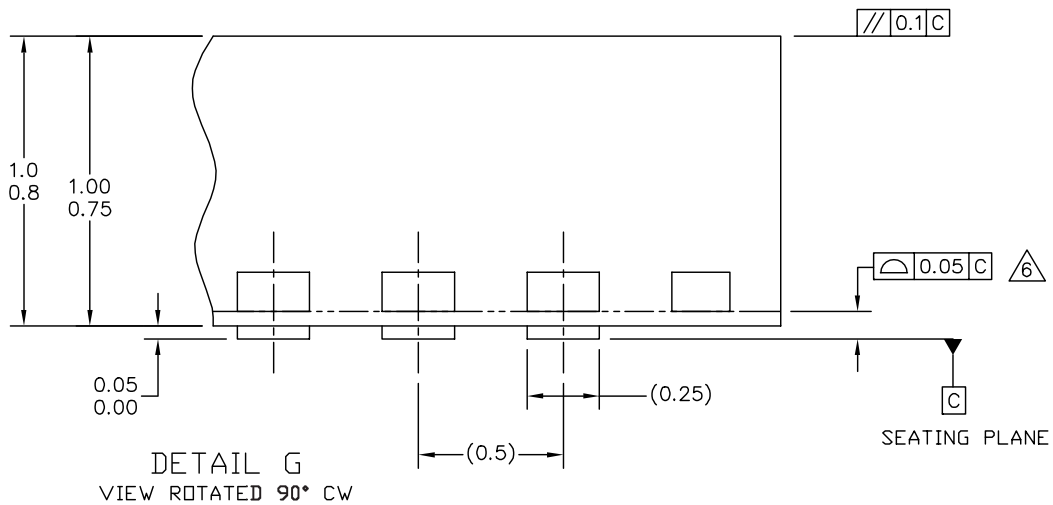
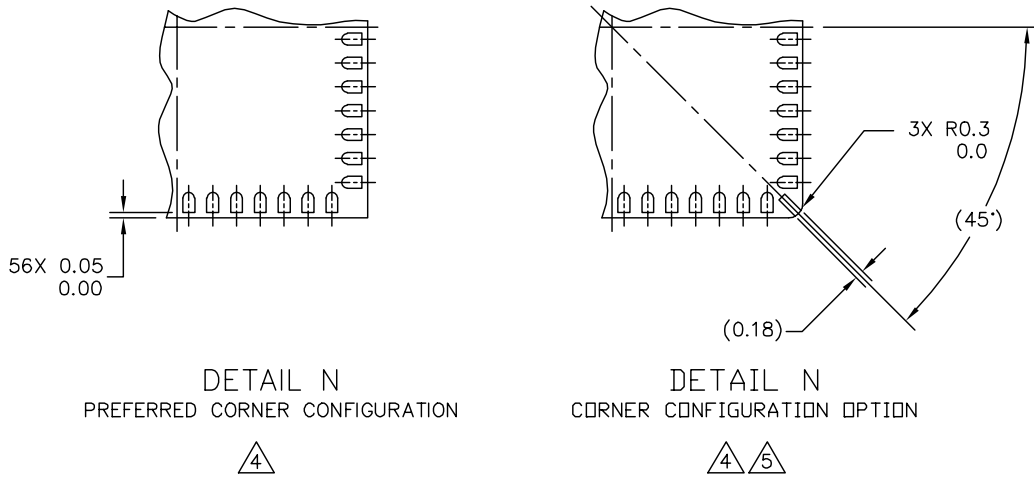

© FREESCALE SEMICONDUCTOR, INC. ALL RIGHTS RESERVED.	MECHANICAL OUTLINE	PRINT VERSION NOT TO SCALE	
TITLE: QUAD FLAT NON-LEADED PACKAGE (QFN) 56 TERMINAL, 0.5 PITCH, (8X8X1)	DOCUMENT NO: 98ARH99036A	REV: B	
	CASE NUMBER: 1312-02	04 JUL 2005	
	STANDARD: NON-JEDEC		

EP SUFFIX
56-LEAD QFN
PLASTIC PACKAGE
98ARH99036A
ISSUE B

[查询"17559"供应商](#)

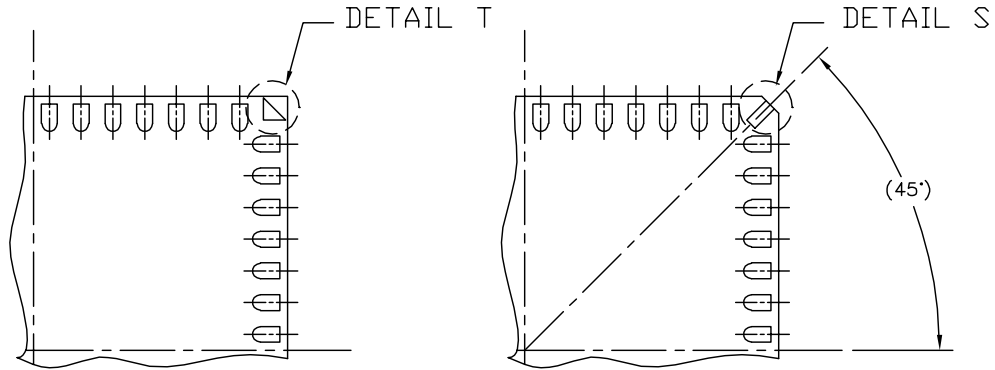

DETAIL M
PREFERRED PIN 1 BACKSIDE IDENTIFIER

DETAIL M
PIN 1 BACKSIDE IDENTIFIER OPTION

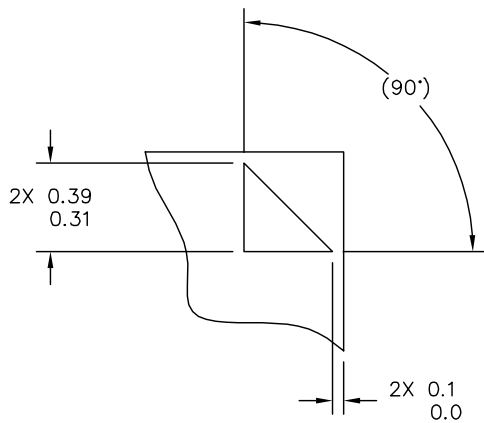

DETAIL T
PREFERRED PIN 1 BACKSIDE IDENTIFIER

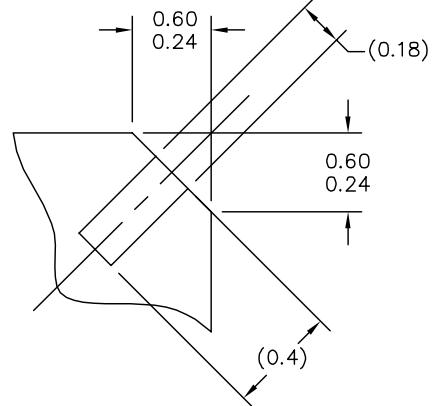

DETAIL S
PIN 1 BACKSIDE IDENTIFIER OPTION

© FREESCALE SEMICONDUCTOR, INC. ALL RIGHTS RESERVED.	MECHANICAL OUTLINE	PRINT VERSION NOT TO SCALE	
TITLE: QUAD FLAT NON-LEADED PACKAGE (QFN) 56 TERMINAL, 0.5 PITCH, (8X8X1)	DOCUMENT NO: 98ARH99036A	REV: B	
	CASE NUMBER: 1312-02	04 JUL 2005	
	STANDARD: NON-JEDEC		

EP SUFFIX
56-LEAD QFN
PLASTIC PACKAGE
98ARH99036A
ISSUE B

[查询"17559"供应商](#)**REVISION HISTORY**

REVISION	DATE	DESCRIPTION OF CHANGES
Rev. 1.0	8/2006	• Initial Release

[查询"17559"供应商](#)

How to Reach Us:

Home Page:
www.freescale.com

E-mail:
support@freescale.com

USA/Europe or Locations Not Listed:
Freescale Semiconductor
Technical Information Center, CH370
1300 N. Alma School Road
Chandler, Arizona 85224
+1-800-521-6274 or +1-480-768-2130
support@freescale.com

Europe, Middle East, and Africa:
Freescale Halbleiter Deutschland GmbH
Technical Information Center
Schatzbogen 7
81829 Muenchen, Germany
+44 1296 380 456 (English)
+46 8 52200080 (English)
+49 89 92103 559 (German)
+33 1 69 35 48 48 (French)
support@freescale.com

Japan:
Freescale Semiconductor Japan Ltd.
Headquarters
ARCO Tower 15F
1-8-1, Shimo-Meguro, Meguro-ku,
Tokyo 153-0064
Japan
0120 191014 or +81 3 5437 9125
support.japan@freescale.com

Asia/Pacific:
Freescale Semiconductor Hong Kong Ltd.
Technical Information Center
2 Dai King Street
Tai Po Industrial Estate
Tai Po, N.T., Hong Kong
+800 2666 8080
support.asia@freescale.com

For Literature Requests Only:
Freescale Semiconductor Literature Distribution Center
P.O. Box 5405
Denver, Colorado 80217
1-800-441-2447 or 303-675-2140
Fax: 303-675-2150
LDCForFreescaleSemiconductor@hibbertgroup.com

RoHS-compliant and/or Pb-free versions of Freescale products have the functionality and electrical characteristics of their non-RoHS-compliant and/or non-Pb-free counterparts. For further information, see <http://www.freescale.com> or contact your Freescale sales representative.

For information on Freescale's Environmental Products program, go to <http://www.freescale.com/epp>.

Information in this document is provided solely to enable system and software implementers to use Freescale Semiconductor products. There are no express or implied copyright licenses granted hereunder to design or fabricate any integrated circuits or integrated circuits based on the information in this document.

Freescale Semiconductor reserves the right to make changes without further notice to any products herein. Freescale Semiconductor makes no warranty, representation or guarantee regarding the suitability of its products for any particular purpose, nor does Freescale Semiconductor assume any liability arising out of the application or use of any product or circuit, and specifically disclaims any and all liability, including without limitation consequential or incidental damages. "Typical" parameters that may be provided in Freescale Semiconductor data sheets and/or specifications can and do vary in different applications and actual performance may vary over time. All operating parameters, including "Typicals", must be validated for each customer application by customer's technical experts. Freescale Semiconductor does not convey any license under its patent rights nor the rights of others. Freescale Semiconductor products are not designed, intended, or authorized for use as components in systems intended for surgical implant into the body, or other applications intended to support or sustain life, or for any other application in which the failure of the Freescale Semiconductor product could create a situation where personal injury or death may occur. Should Buyer purchase or use Freescale Semiconductor products for any such unintended or unauthorized application, Buyer shall indemnify and hold Freescale Semiconductor and its officers, employees, subsidiaries, affiliates, and distributors harmless against all claims, costs, damages, and expenses, and reasonable attorney fees arising out of, directly or indirectly, any claim of personal injury or death associated with such unintended or unauthorized use, even if such claim alleges that Freescale Semiconductor was negligent regarding the design or manufacture of the part.

Freescale™ and the Freescale logo are trademarks of Freescale Semiconductor, Inc. All other product or service names are the property of their respective owners.

© Freescale Semiconductor, Inc., 2006. All rights reserved.