

## General Description

The MIC4684 is a high-efficiency 200kHz stepdown (buck) switching regulator. Power conversion efficiency of above 85% is easily obtainable for a wide variety of applications. The MIC4684 achieves 2A of continuous current in an 8-lead SO (small outline) package at 60°C ambient temperature.

High efficiency is maintained over a wide output current range by utilizing a boost capacitor to increase the voltage available to saturate the internal power switch. As a result of this high efficiency, no external heat sink is required. The MIC4684, housed in an SO-8, can replace larger TO-220 and TO-263 packages in many applications.

The MIC4684 allows for a high degree of safety. It has a wide input voltage range of 4V to 30V (34V transient), allowing it to be used in applications where input voltage transients may be present. Built-in safety features include over-current protection, frequency-foldback short-circuit protection, and thermal shutdown.

The MIC4684 is available in an 8-lead SO package with a junction temperature range of -40°C to +125°C.

## Features

- SO-8 package with 2A continuous output current
- Over 85% efficiency
- Fixed 200kHz PWM operation
- Wide 4V to 30V input voltage range
- Output voltage adjustable to 1.235V
- All surface mount solution
- Internally compensated with fast transient response
- Over-current protection
- Frequency foldback short-circuit protection
- Thermal shutdown

## Applications

- Simple high-efficiency step-down regulator
- 5V to 3.3V/1.7A converter (60°C ambient)
- 12V to 1.8V/2A converter (60°C ambient)
- On-card switching regulator
- Dual-output ±5V converter
- Battery charger

## Ordering Information

Part Number	Voltage	Junction Temperature Range	Package
MIC4684BM	Adj	-40°C to +125°C	SOP-8

## Typical Application

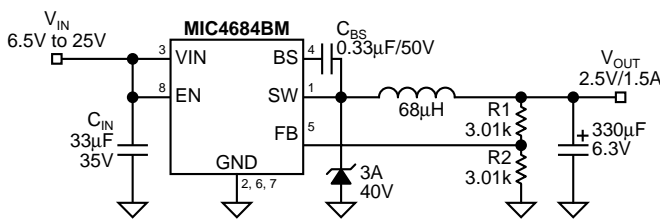

**Adjustable Buck Converter**

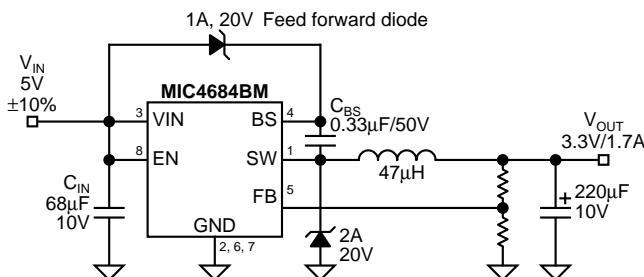

**5V to 3.3V Converter**

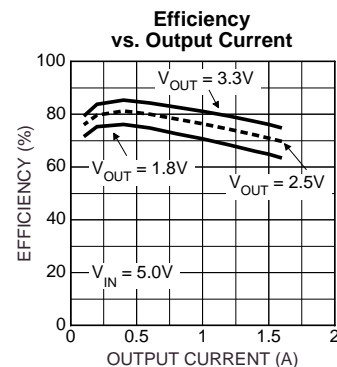

**Efficiency vs. Output Current**

## Pin Configuration

[查询"MIC4684"供应商](#)

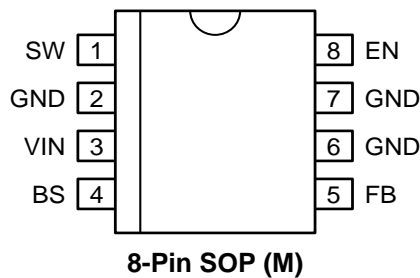

## Pin Description

Pin Number	Pin Name	Pin Function
1	SW	Switch (Output): Emitter of NPN output switch. Connect to external storage inductor and Shottky diode.
2, 6, 7	GND	Ground
3	IN	Supply (Input): Unregulated +4V to 30V supply voltage (34V transient)
4	BS	Bootstrap Voltage Node (External Component): Connect to external boost capacitor.
5	FB	Feedback (Input): Outback voltage feedback to regulator. Connect to output of supply for fixed versions. Connect to 1.23V tap of resistive divider for adjustable versions.
8	EN	Enable (Input): Logic high = enable; logic low = shutdown

## Detailed Pin Description

### Switch (SW, pin 1)

The switch pin is tied to the emitter of the main internal NPN transistor. This pin is biased up to the input voltage minus the  $V_{SAT}$  of the main NPN pass element. The emitter is also driven negative when the output inductor's magnetic field collapses at turn-off. During the OFF time the SW pin is clamped by the output schottky diode to a  $-0.5V$  typically.

### Ground (GND, pins 2,6,7)

There are two main areas of concern when it comes to the ground pin, EMI and ground current. In a buck regulator or any other non-isolated switching regulator the output capacitor(s) and diode(s) ground is referenced back to the switching regulator's or controller's ground pin. Any resistance between these reference points causes an offset voltage/IR drop proportional to load current and poor load regulation. This is why its important to keep the output grounds placed as close as possible to the switching regulator's ground pin. To keep radiated EMI to a minimum its necessary to place the input capacitor ground lead as close as possible to the switching regulators ground pin.

### Input Voltage ( $V_{IN}$ , pin 3)

The  $V_{IN}$  pin is the collector of the main NPN pass element. This pin is also connected to the internal regulator. The output diode or clamping diode should have its cathode as close as possible to this point to avoid voltage spikes adding to the voltage across the collector.

### Bootstrap (BS, pin 4)

The bootstrap pin in conjunction with the external bootstrap capacitor provides a bias voltage higher than the input voltage to the MIC4684's main NPN pass element. The bootstrap capacitor sees the  $dv/dt$  of the switching action at the SW pin as an AC voltage. The bootstrap capacitor then couples the AC voltage back to the BS pin plus the dc offset of  $V_{IN}$  where it is rectified and used to provide additional drive to the main switch, in this case a NPN transistor.

This additional drive reduces the NPN's saturation voltage and increases efficiency, from a  $V_{SAT}$  of 1.8V, and 75% efficiency to a  $V_{SAT}$  of 0.5V and 88% efficiency respectively.

### Feedback (FB, pin 5)

The feedback pin is tied to the inverting side of a GM error amplifier. The noninverting side is tied to a 1.235V bandgap reference. Fixed voltage versions have an internal voltage divider from the feedback pin. Adjustable versions require an external resistor voltage divider from the output to ground, with the center tied to the feedback pin.

### Enable (EN, pin 8)

The enable (EN) input is used to turn on the regulator and is TTL compatible. Note: connect the enable pin to the input if unused. A logic-high enables the regulator. A logic-low shuts down the regulator and reduces the stand-by quiescent input current to typically  $150\mu A$ . The enable pin has an upper threshold of 2.0V minimum and lower threshold of 0.8V maximum. The hysteresis provided by the upper and lower thresholds acts as an UVLO and prevents unwanted turn on of the regulator due to noise.

**Absolute Maximum Ratings (Note 1)**

Supply Voltage ( $V_{IN}$ ) <b>Note 3</b>	+34V
Enable Voltage ( $V_{EN}$ )	-0.3V to $V_{IN}$
Steady-State Output Switch Voltage ( $V_{SW}$ )	-1V to $V_{IN}$
Feedback Voltage ( $V_{FB}$ )	+12V
Storage Temperature ( $T_S$ )	-65°C to +150°C
ESD Rating	<b>Note 3</b>

**Operating Ratings (Note 2)**

Supply Voltage ( $V_{IN}$ ) <b>Note 4</b>	+4V to +30V
Ambient Temperature ( $T_A$ )	-40°C to +85°C
Junction Temperature ( $T_J$ )	-40°C to +125°C
Package Thermal Resistance	
$\theta_{JA}$ , <b>Note 5</b>	75°C/W
$\theta_{JC}$ , <b>Note 5</b>	25°C/W

**Electrical Characteristics**

$V_{IN} = V_{EN} = 12V$ ,  $V_{OUT} = 5V$ ;  $I_{OUT} = 500mA$ ;  $T_A = 25^\circ C$ , unless otherwise noted. **Bold** values indicate  $-40^\circ C \leq T_J \leq +125^\circ C$ .

Parameter	Condition	Min	Typ	Max	Units
Feedback Voltage	( $\pm 2\%$ )	1.210	1.235	1.260	V
	( $\pm 3\%$ )	<b>1.198</b>		<b>1.272</b>	V
	$8V \leq V_{IN} \leq 30V$ , $0.1A \leq I_{LOAD} \leq 1A$ , $V_{OUT} = 5V$	1.186	1.235	1.284	V
		<b>1.173</b>		<b>1.297</b>	V
Feedback Bias Current			50		nA
Maximum Duty Cycle	$V_{FB} = 1.0V$		94		%
Output Leakage Current	$V_{IN} = 30V$ , $V_{EN} = 0V$ , $V_{SW} = 0V$		5	500	$\mu A$
	$V_{IN} = 30V$ , $V_{EN} = 0V$ , $V_{SW} = -1V$		1.4	20	mA
Quiescent Current	$V_{FB} = 1.5V$		6	<b>12</b>	mA
Bootstrap Drive Current	$V_{FB} = 1.5V$ , $V_{SW} = 0V$	250	380		mA
Bootstrap Voltage	$I_{BS} = 10mA$ , $V_{FB} = 1.5V$ , $V_{SW} = 0V$	5.5	6.2		V
Frequency Fold Back	$V_{FB} = 0V$	30	50	120	kHz
Oscillator Frequency		180	200	225	kHz
Saturation Voltage	$I_{OUT} = 1A$		0.59		V
Short Circuit Current Limit	$V_{FB} = 0V$ , See <i>Test Circuit</i>	2.2			A
Shutdown Current	$V_{EN} = 0V$		150		$\mu A$
Enable Input Logic Level	regulator on	2			V
	regulator off			0.8	V
Enable Pin Input Current	$V_{EN} = 0V$ (regulator off)		16	50	$\mu A$
	$V_{EN} = 12V$ (regulator on)	-1	-0.83		mA
Thermal Shutdown @ $T_J$			160		$^\circ C$

**Note 1.** Exceeding the absolute maximum rating may damage the device.

**Note 2.** The device is not guaranteed to function outside its operating rating.

**Note 3.** Devices are ESD sensitive. Handling precautions recommended.

**Note 4.** 2.5V of headroom is required between  $V_{IN}$  and  $V_{OUT}$ . The headroom can be reduced by implementing a feed-forward diode as seen on the 5V to 3.3V circuit on page 1.

**Note 5.** Measured on 1" square of 1 oz. copper FR4 printed circuit board connected to the device ground leads.

### Test Circuit

[查询"MIC4684"供应商](#)

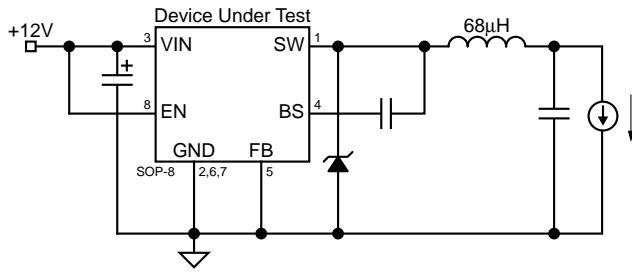

Current Limit Test Circuit

### Shutdown Input Behavior

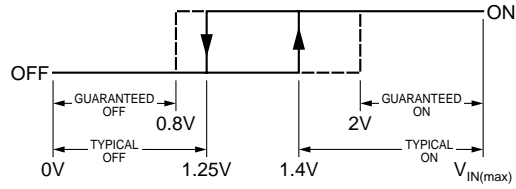

Enable Hysteresis

# Typical Characteristics

(T<sub>A</sub> = 25°C unless otherwise noted)

[查询MIC4684 供应商](#)

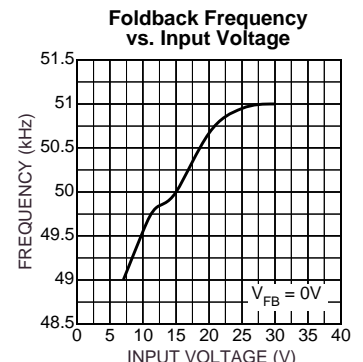
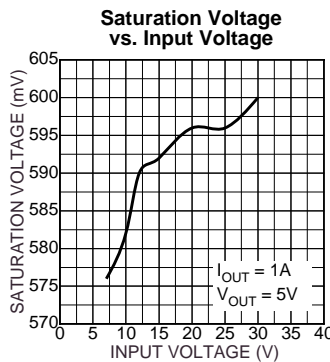
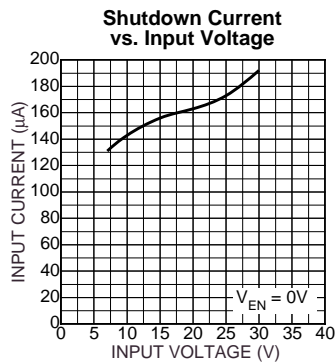
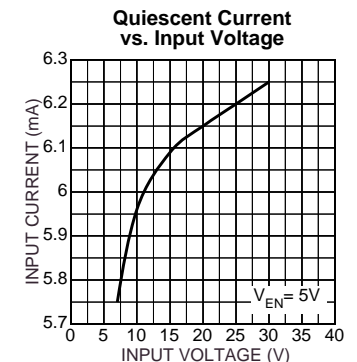
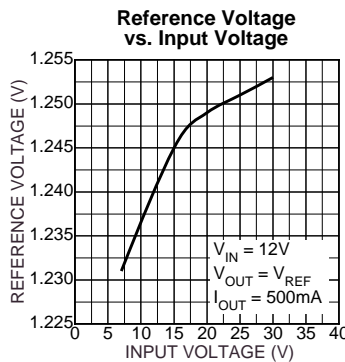
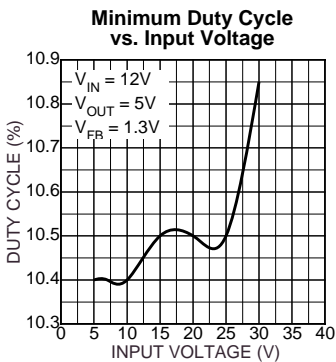
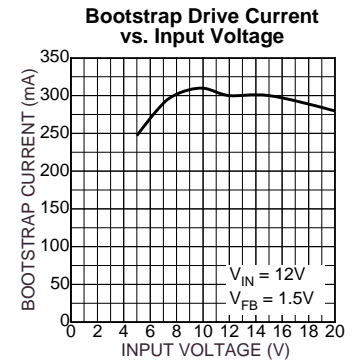
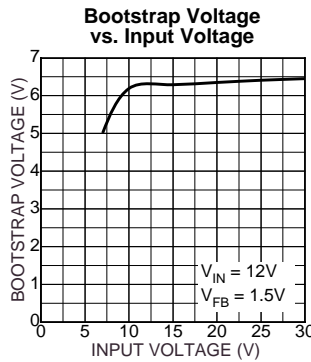
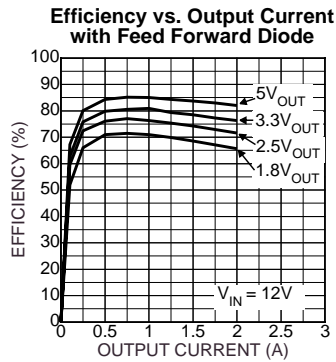
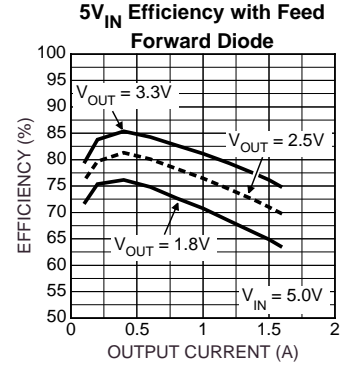
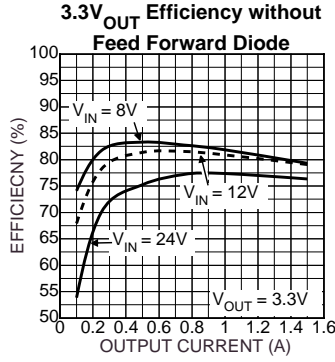
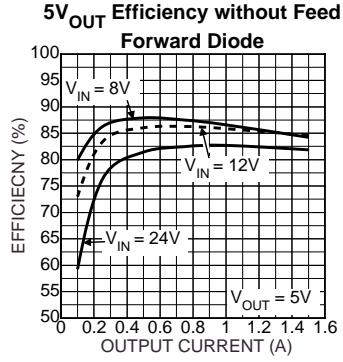

[查询"MIC4684"供应商](#)

**Feedback Voltage vs. Temperature**

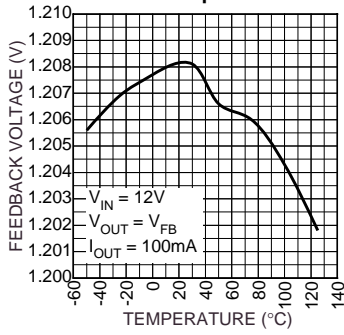

**Shutdown Hysteresis vs. Temperature**

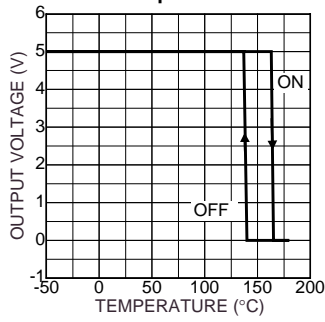

**Load Regulation**

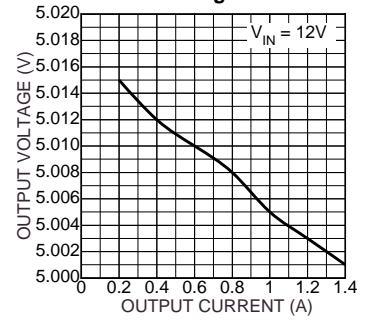

**Line Regulation**

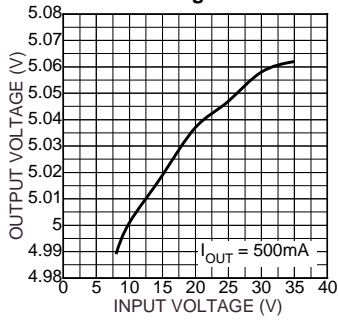

**Enable Threshold vs. Temperature**

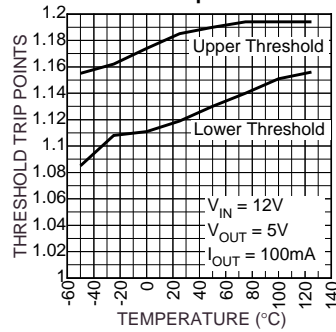

[查询"MIC4684"供应商](#)

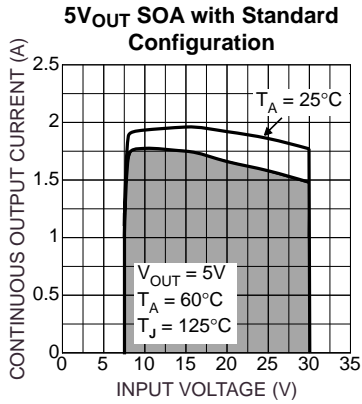

SOA Measured on the MIC4684 Evaluation Board.

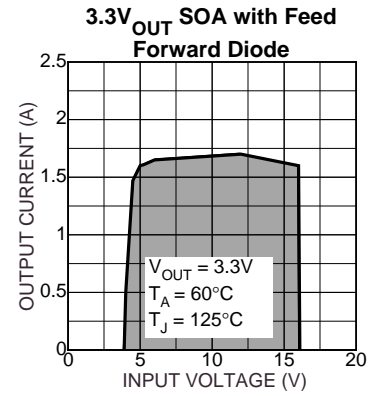

SOA Measured on the MIC4684 Evaluation Board.

Note 1. With feed-forward diode implementation as seen in 5V to 3.3V circuit on page 1.

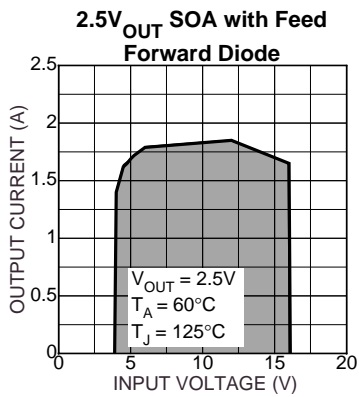

SOA measured on the MIC4684 Evaluation Board.

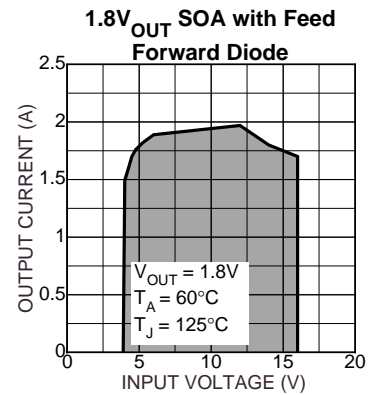

SOA measured on the MIC4684 Evaluation Board.

# Functional Characteristics

[查询"MIC4684"供应商](#)

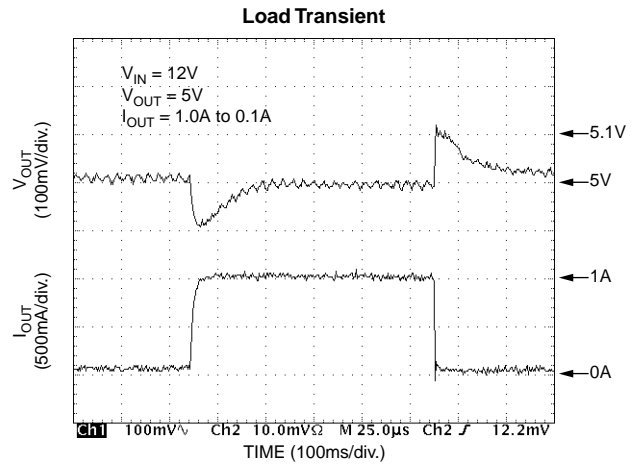
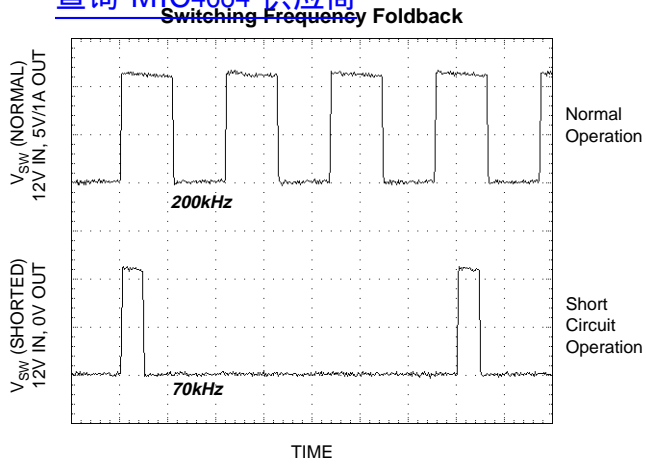

## Frequency Foldback

The MIC4684 folds the switching frequency back during a hard short circuit condition to reduce the energy per cycle and protect the device.



## Block Diagrams

[查询"MIC4684"供应商](#)

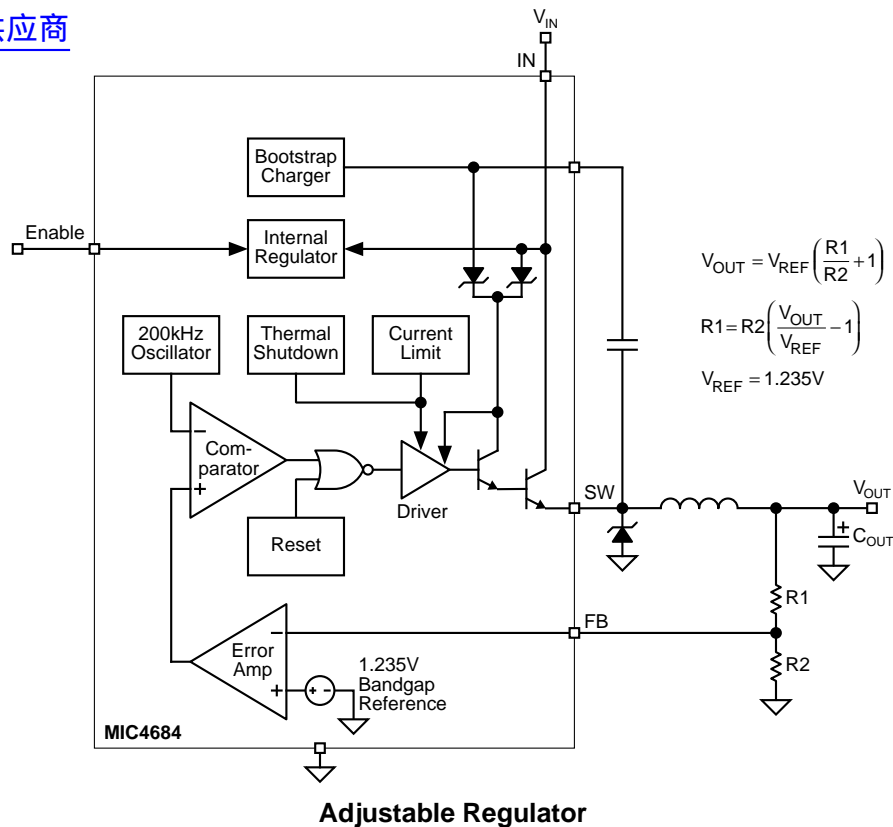

## Functional Description

The MIC4684 is a variable duty cycle switch-mode regulator with an internal power switch. Refer to the above block diagram.

### Supply Voltage

The MIC4684 operates from a +4V to +30V (34V transient) unregulated input. Highest efficiency operation is from a supply voltage around +12V. See the efficiency curves on page 5.

### Enable/Shutdown

The enable (EN) input is TTL compatible. Tie the input high if unused. A logic-high enables the regulator. A logic-low shuts down the internal regulator which reduces the current to typically 150μA when  $V_{EN} = 0V$ .

### Feedback

Fixed-voltage versions of the regulator have an internal resistive divider from the feedback (FB) pin. Connect FB directly to the output voltage.

Adjustable versions require an external resistive voltage divider from the output voltage to ground, center tapped to the FB pin. See Table 1 and Table 2 for recommended resistor values.

### Duty Cycle Control

A fixed-gain error amplifier compares the feedback signal with a 1.235V bandgap voltage reference. The resulting error

amplifier output voltage is compared to a 200kHz sawtooth waveform to produce a voltage controlled variable duty cycle output.

A higher feedback voltage increases the error amplifier output voltage. A higher error amplifier voltage (comparator inverting input) causes the comparator to detect only the peaks of the sawtooth, reducing the duty cycle of the comparator output. A lower feedback voltage increases the duty cycle. The MIC4684 uses a voltage-mode control architecture.

### Output Switching

When the internal switch is ON, an increasing current flows from the supply  $V_{IN}$ , through external storage inductor L1, to output capacitor  $C_{OUT}$  and the load. Energy is stored in the inductor as the current increases with time.

When the internal switch is turned OFF, the collapse of the magnetic field in L1 forces current to flow through fast recovery diode D1, charging  $C_{OUT}$ .

### Output Capacitor

External output capacitor  $C_{OUT}$  provides stabilization and reduces ripple.

### Return Paths

During the ON portion of the cycle, the output capacitor and load currents return to the supply ground. During the OFF portion of the cycle, current is being supplied to the output capacitor and load by storage inductor L1, which means that D1 is part of the high-current return path.

## Applications Information

### Adjustable Regulators 查询“MIC4684”供应商

Adjustable regulators require a 1.23V feedback signal. Recommended voltage-divider resistor values for common output voltages are included in Table 1.

For other voltages, the resistor values can be determined using the following formulas:

$$V_{OUT} = V_{REF} \left( \frac{R1}{R2} + 1 \right)$$

$$R1 = R2 \left( \frac{V_{OUT}}{V_{REF}} - 1 \right)$$

$$V_{REF} = 1.235V$$

### Minimum Pulse Width

The minimum duty cycle of the MIC4684 is approximately 10%. See *Minimum Duty Cycle Graph*. If this input-to-output voltage characteristic is exceeded, the MIC4684 will skip cycles to maintain a regulated  $V_{OUT}$ .

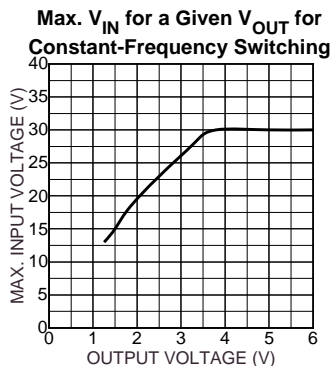

Figure 1. Minimum Pulse Width Characteristic

### Thermal Considerations

The MIC4684 SuperSwitcher™ features the power-SOP-8. This package has a standard 8-lead small-outline package profile, but with much higher power dissipation than a standard SOP-8. Micrel's MIC4684 SuperSwitcher™ family are the first dc-to-dc converters to take full advantage of this package.

The reason that the power SOP-8 has higher power dissipation (lower thermal resistance) is that pins 2, 6, and 7 and the die-attach paddle are a single piece of metal. The die is attached to the paddle with thermally conductive adhesive. This provides a low thermal resistance path from the junction of the die to the ground pins. This design significantly improves package power dissipation by allowing excellent heat transfer through the ground leads to the printed circuit board.

One limitation of the maximum output current on any MIC4684 design is the junction-to-ambient thermal resistance ( $\theta_{JA}$ ) of the design (package and ground plane).

Examining  $\theta_{JA}$  in more detail:

$$\theta_{JA} = (\theta_{JC} + \theta_{CA})$$

where:

$\theta_{JC}$  = junction-to-case thermal resistance

$\theta_{CA}$  = case-to-ambient thermal resistance

$\theta_{JC}$  is a relatively constant 25°C/W for a power SOP-8.

$\theta_{CA}$  is dependent on layout and is primarily governed by the connection of pins 2, 6, and 7 to the ground plane. The purpose of the ground plane is to function as a heat sink.

$\theta_{JA}$  is ideally 75°C/W, but will vary depending on the size of the ground plane to which the power SOP-8 is attached.

### Determining Ground-Plane Heat-Sink Area

Make sure that MIC4684 pins 2, 6, and 7 are connected to a ground plane with a minimum area of 6cm<sup>2</sup>. This ground plane should be as close to the MIC4684 as possible. The area may be distributed in any shape around the package or on any pcb layer *as long as there is good thermal contact to pins 2, 6, and 7*. This ground plane area is more than sufficient for most designs.

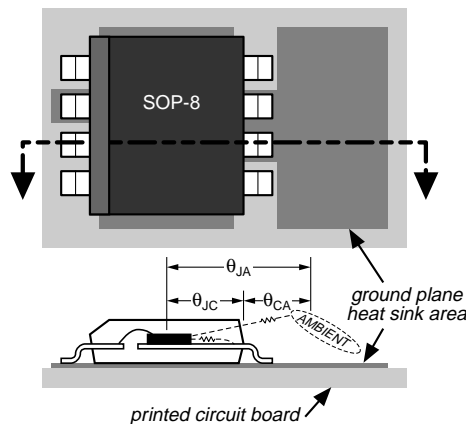

Figure 2. Power SOP-8 Cross Section

When designing with the MIC4684, it is a good practice to connect pins 2, 6, and 7 to the largest ground plane that is practical for the specific design.

### Checking the Maximum Junction Temperature:

For this example, with an output power ( $P_{OUT}$ ) of 5W, (5V output at 1A with  $V_{IN} = 12V$ ) and 60°C maximum ambient temperature, what is the junction temperature?

Referring to the “Typical Characteristics: 5V Output Efficiency” graph, read the efficiency ( $\eta$ ) for 1A output current at  $V_{IN} = 12V$  or perform your own measurement.

$$\eta = 84\%$$

The efficiency is used to determine how much of the output power ( $P_{OUT}$ ) is dissipated in the regulator circuit ( $P_D$ ).

$$P_D = \frac{P_{OUT}}{\eta} - P_{OUT}$$

$$P_D = \frac{5W}{0.84} - 5W$$

$$P_D = 0.95W$$

A worst-case rule of thumb is to assume that 80% of the total output power dissipation is in the MIC4684 ( $P_{D(IC)}$ ) and 20% is in the diode and inductor/capacitor circuit.

$$P_{D(IC)} = 0.8 P_D$$

$$P_{D(IC)} = 0.8 \times 0.95W$$

$$P_{D(IC)} = 0.76W$$

Calculate the worst-case junction temperature:

$$T_J = P_{D(IC)} \theta_{JC} + (T_C - T_A) + T_{A(max)}$$

where:

$T_J$  = MIC4684 junction temperature

$P_{D(IC)}$  = MIC4684 power dissipation

$\theta_{JC}$  = junction-to-case thermal resistance.

The  $\theta_{JC}$  for the MIC4684's power-SOP-8 is approximately 25°C/W.

$T_C$  = "pin" temperature measurement taken at the entry point of pins 2, 6 or 7

$T_A$  = ambient temperature

$T_{A(max)}$  = maximum ambient operating temperature for the specific design.

Calculating the maximum junction temperature given a maximum ambient temperature of 60°C:

$$T_J = 0.76 \times 25^\circ\text{C/W} + (41^\circ\text{C} - 25^\circ\text{C}) + 60^\circ\text{C}$$

$$T_J = 95^\circ\text{C}$$

This value is within the allowable maximum operating junction temperature of 125°C as listed in "Operating Ratings." Typical thermal shutdown is 160°C and is listed in *Electrical Characteristics*. Also see SOA curves on pages 7 through 8.

### Layout Considerations

Layout is very important when designing any switching regulator. Rapidly changing currents through the printed circuit board traces and stray inductance can generate voltage transients which can cause problems.

To minimize stray inductance and ground loops, keep trace lengths as short as possible. For example, keep D1 close to pin 1 and pins 2, 6, and 7, keep L1 away from sensitive node FB, and keep  $C_{IN}$  close to pin 3 and pins 2, 6, and 7. See *Applications Information: Thermal Considerations* for ground plane layout.

The feedback pin should be kept as far way from the switching elements (usually L1 and D1) as possible.

A circuit with sample layouts are provided. See Figure 7. Gerber files are available upon request.

### Feed Forward Diode

The FF diode (feed forward) provides an external bias source directly to the main pass element, this reduces  $V_{SAT}$  thus allowing the MIC4684 to be used in very low head-room applications I.E.  $5V_{IN}$  to  $3.3V_{OUT}$ .

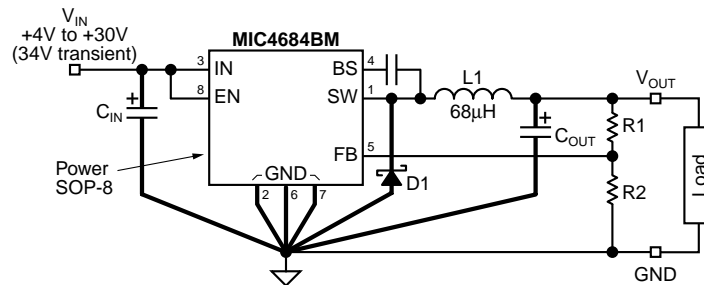

Figure 5. Critical Traces for Layout

## Recommended Components for a Given Output Voltage (Feed-Forward Configuration)

[查询"MIC4684"供应商](#)

$V_{IN} = 4V$  to  $16V$  (in feed-forward configuration)

$V_{OUT}$	$I_{OUT}$	R1	R2	$V_{IN}$	$C_{IN}$	D1	D2	L1	$C_{OUT}$
5.0V	1.6A	3.01k	976k $\Omega$	6.5V–16V	47 $\mu$ F, 20V Vishay-Dale 595D476X0020D2T	2A, 30V Schottky SS23	1A, 20V Schottky MBRX120	27 $\mu$ H Sumida CDH74-270MC	120 $\mu$ F, 6.3V Vishay-Dale 594D127X06R3C2T
3.3V	1.7A	3.01k	1.78k	4.85V–16V	47 $\mu$ F, 20V Vishay-Dale 595D476X0020D2T	2A, 30V Schottky SS23	1A, 20V Schottky MBRX120	27 $\mu$ H Sumida CDH74-270MC	220 $\mu$ F, 6.3V Vishay-Dale 594D227X06R3C2T
2.5V	1.8A	3.01k	2.94k	4.5V–16V	47 $\mu$ F, 20V Vishay-Dale 595D476X0020D2T	2A, 30V Schottky SS23	1A, 20V Schottky MBRX120	27 $\mu$ H Sumida CDH74-270MC	330 $\mu$ F, 6.3V Vishay-Dale 594D337X06R3D2T
1.8V	2A	3.01k	6.49k	4.2V–16V	47 $\mu$ F, 20V Vishay-Dale 595D476X0020D2T	2A, 30V Schottky SS23	1A, 20V Schottky MBRX120	27 $\mu$ H Sumida CDH74-270MC	330 $\mu$ F, 6.3V Vishay-Dale 594D337X06R3D2T

Note 1. This bill of materials assumes the use of feedforward schottky diode from  $V_{IN}$  to the bootstrap pin.

**Table 1. Recommended Components for Common Output Voltages**  
( $V_{IN} = 4V$  to  $16V$ )

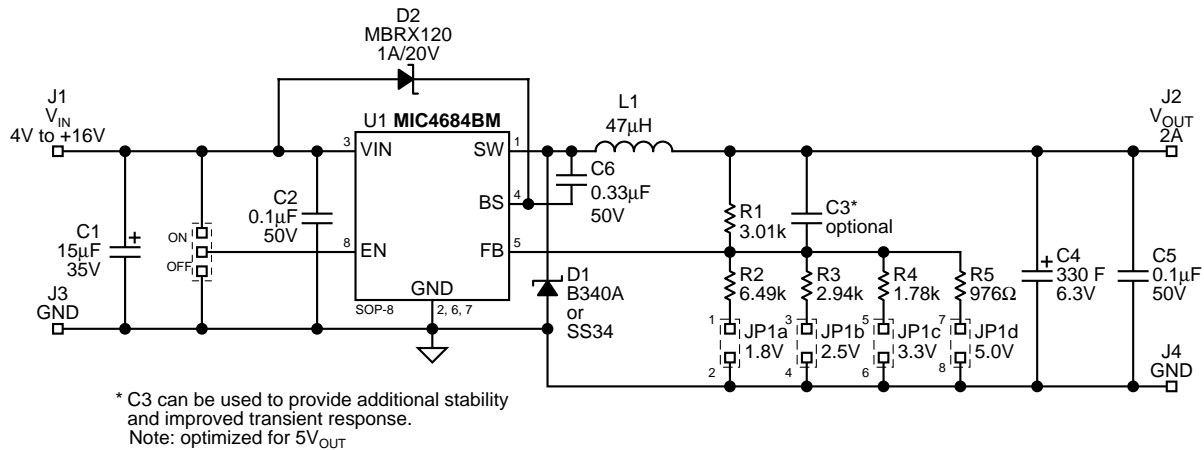

**Figure 6. 4V - 16V Input Evaluation Board Schematic Diagram**

## Printed Circuit Board

Evaluation Board Optimized for Low Input Voltage by using Feed-Forward Diode Configuration ( $V_{IN} = 4V$  to  $16V$ )

[查询 MIC4684 供应商](#)

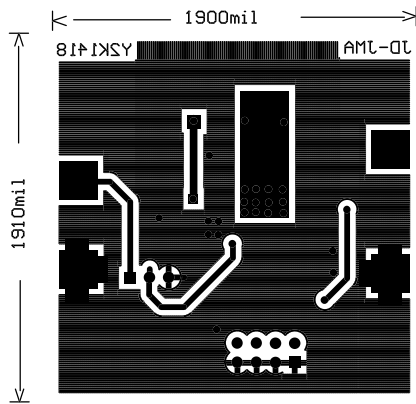

Figure 7a. Bottom Side Copper

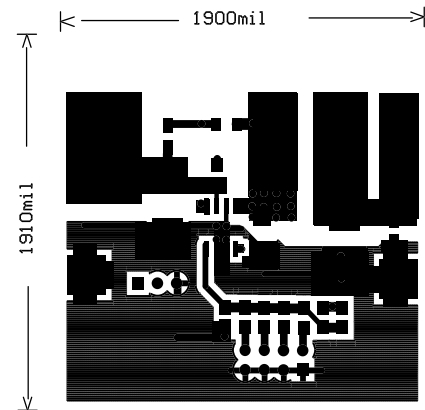

Figure 7b. Top Side Copper

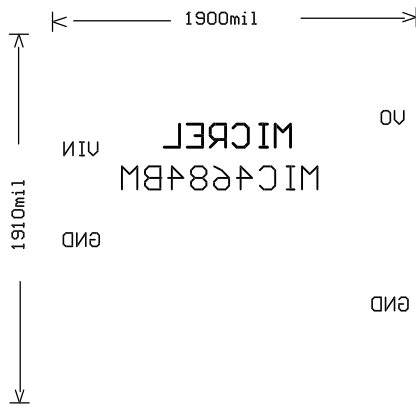

Figure 7c. Bottom Side Silk Screen

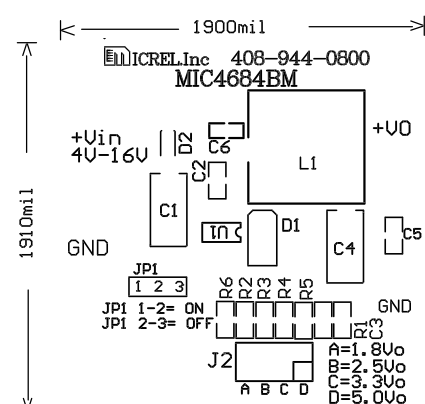

Figure 7d. Top Side Silk Screen

### Abbreviated Bill of Material (Critical Components)

Reference	Part Number	Manufacturer	Description	Qty
C1	594D156X0035D2T	Vishay Sprague <sup>1</sup>	15 $\mu$ F 35V	1
C2, C5	VJ0805Y104KXAAB	Vitramon	0.1 $\mu$ F 50V	2
C6	GRM426X7R334K50	Murata	0.33 $\mu$ F, 50V ceramic capacitor	
C3	Optional		1800pF, 50V ceramic	(1)
C4	594D337X06R3D2T	Vishay Sprague <sup>2</sup>	330 $\mu$ F, 6.3V, tantalum	1
D1	B340A	Diode Inc <sup>3</sup>	Schottky 3A, 40V	1
D2	MBRX120	Micro Com. Components <sup>5</sup>	Schottky 1A, 20V	1
L1	CDRH104R-470MC	Sumida <sup>4</sup>	47 $\mu$ H, 2.1A $I_{SAT}$	1
U1	<b>MIC4684BM</b>	Micrel Semiconductor <sup>6</sup>	1A 200kHz power-SO-8 buck regulator	1

<sup>1</sup> Vishay Dale, Inc., tel: 1 402-644-4218, <http://www.vishay.com>

<sup>2</sup> Vishay Sprague, Inc., tel: 1 207-490-7256, <http://www.vishay.com>

<sup>3</sup> Diodes Inc, tel: (805) 446-4800, <http://www.diodes.com>

<sup>4</sup> Sumida, tel: (408) 982-9960, <http://www.sumida.com>

<sup>5</sup> Micro Commercial Components, tel: (800) 346-3371

<sup>6</sup> Micrel, tel: (408) 944-0800, <http://www.micrel.com>

## Recommended Components for a Given Output Voltage (Standard Configuration)

[查询"MIC4684"供应商](#)

$V_{IN} = 4V \text{ to } 30V$

$V_{OUT}$	$I_{OUT}$	R1	R2	$V_{IN}$	$C_{IN}$	D1	L1	$C_{OUT}$
5.0V	1.7A	3.01k	976k $\Omega$	8V–30V	33 $\mu$ F, 35V Vishay-Dale 595D336X0035R2T	3A, 40V Schottky SS34	68 $\mu$ H Sumida CDRH104R-680MC	120 $\mu$ F, 6.3V Vishay-Dale 594D127X06R3C2T
3.3V	1.5A	3.01k	1.78k	7V–28V	33 $\mu$ F, 35V Vishay-Dale 595D336X0035R2T	3A, 40V Schottky SS34	68 $\mu$ H Sumida CDRH104R-680MC	220 $\mu$ F, 6.3V Vishay-Dale 594D227X06R3C2T
2.5V	1.5A	3.01k	2.94k	6.5V–23V	33 $\mu$ F, 35V Vishay-Dale 595D336X0035R2T	3A, 40V Schottky SS34	68 $\mu$ H Sumida CDRH104R-680MC	330 $\mu$ F, 6.3V Vishay-Dale 594D337X06R3D2T
1.8V	1.5A	3.01k	6.49k	6V–17V	47 $\mu$ F, 25V Vishay-Dale 595D476X0025D2T	3A, 40V Schottky SS34	68 $\mu$ H Sumida CDRH104R-680MC	330 $\mu$ F, 6.3V Vishay-Dale 594D337X06R3D2T

**Table 2. Recommended Components for Common Output Voltages ( $V_{IN} = 4V \text{ to } 30V$ )**

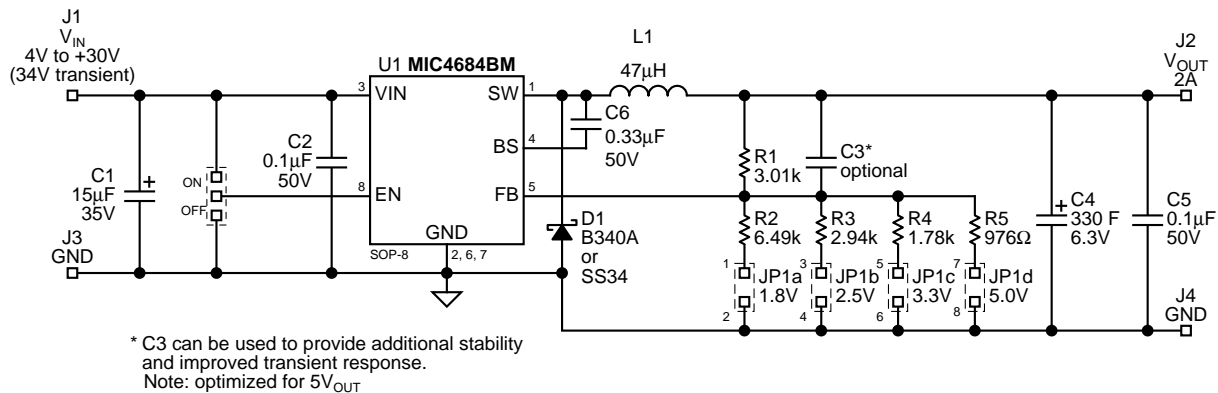

**Figure 6a. 4V - 30V Input Evaluation Board Schematic Diagram**

## Printed Circuit Board

General Purpose Evaluation Board ( $V_{IN} = 4V$  to  $30V$ )

[查询 MIC4684 供应商](#)

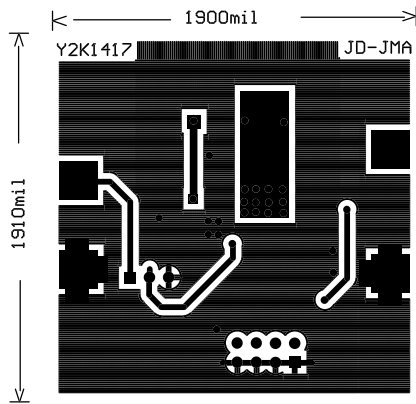

Figure 7a. Bottom Side Copper

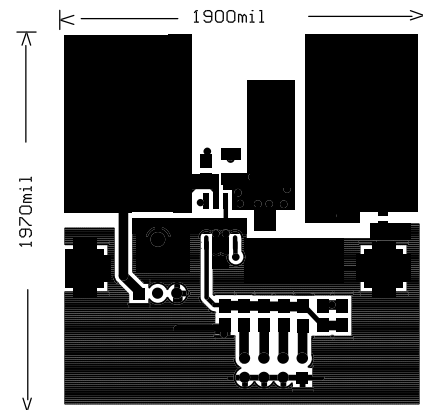

Figure 7b. Top Side Copper

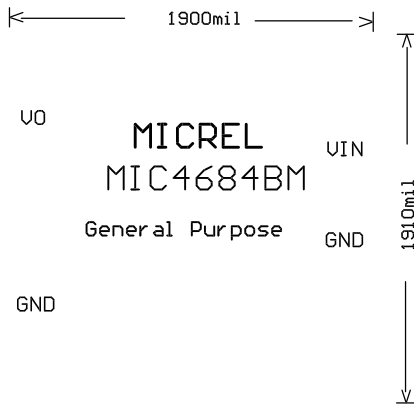

Figure 7c. Bottom Side Silk Screen

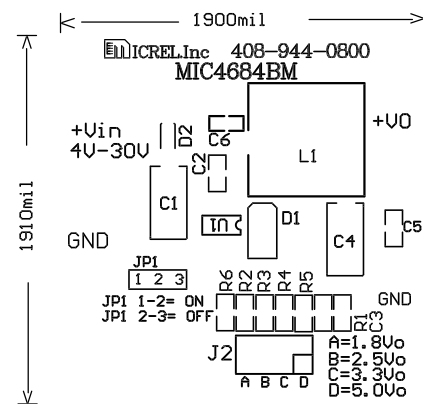

Figure 7d. Top Side Silk Screen

### Abbreviated Bill of Material (Critical Components)

Reference	Part Number	Manufacturer	Description	Qty
C1	594D156X0035D2T	Vishay Sprague <sup>1</sup>	15 $\mu$ F 35V	1
C2, C5	VJ0805Y104KXAAB	Vitramon	0.1 $\mu$ F 50V	2
C6	GRM426X7R334K50	Murata	0.33 $\mu$ F, 50V ceramic capacitor	
C3	Optional		1800pF, 50V ceramic	(1)
C4	594D337X06R3D2T	Vishay Sprague <sup>2</sup>	330 $\mu$ F, 6.3V, tantalum	1
D1	B340A	Diode Inc <sup>3</sup>	Schottky 3A 40V	1
L1	CDRH104R-470MC	Sumida <sup>4</sup>	47 $\mu$ H, 2.1A $I_{SAT}$	1
U1	<b>MIC4684BM</b>	Micrel Semiconductor <sup>5</sup>	1A 200kHz power-SO-8 buck regulator	1

<sup>1</sup> Vishay Dale, Inc., tel: 1 402-644-4218, <http://www.vishay.com>

<sup>2</sup> Vishay Sprague, Inc., tel: 1 207-490-7256, <http://www.vishay.com>

<sup>3</sup> Diodes Inc, tel: (805) 446-4800, <http://www.diodes.com>

<sup>4</sup> Sumida, tel: (408) 982-9960, <http://www.sumida.com>

<sup>5</sup> Micrel, tel: (408) 944-0800, <http://www.micrel.com>

## Package Information

[查询"MIC4684"供应商](#)

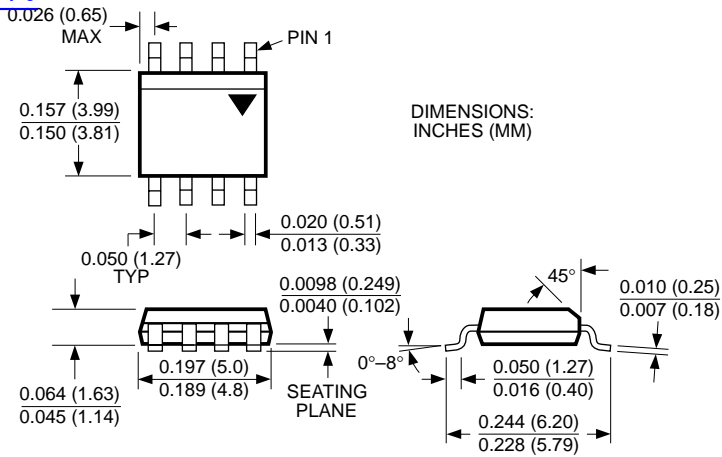

**8-Lead SOP (M)**

**MICREL INC. 1849 FORTUNE DRIVE SAN JOSE, CA 95131 USA**

TEL + 1 (408) 944-0800 FAX + 1 (408) 944-0970 WEB <http://www.micrel.com>

This information is believed to be accurate and reliable, however no responsibility is assumed by Micrel for its use nor for any infringement of patents or other rights of third parties resulting from its use. No license is granted by implication or otherwise under any patent or patent right of Micrel Inc.

© 2001 Micrel Incorporated