

THIS DRAWING IS UNPUBLISHED. RELEASED FOR PUBLICATION, 19 .
 查询"745205-2"供应商 BY AMP INCORPORATED. ALL INTERNATIONAL RIGHTS RESERVED.

LOC	DIST	P	F	ZONE	LTR	DESCRIPTION	DATE	APPD
BD	48				D	REDRAWN ON CAD	4-9-90	-
					E	REV PER ECN BD5813	01/24/92	RM
					F	OBS -4 PER EC 0020-1534-93	04/12/94	PR
					G	OBS -3 PER EC 0020-778-95	31 JAN 96	CS

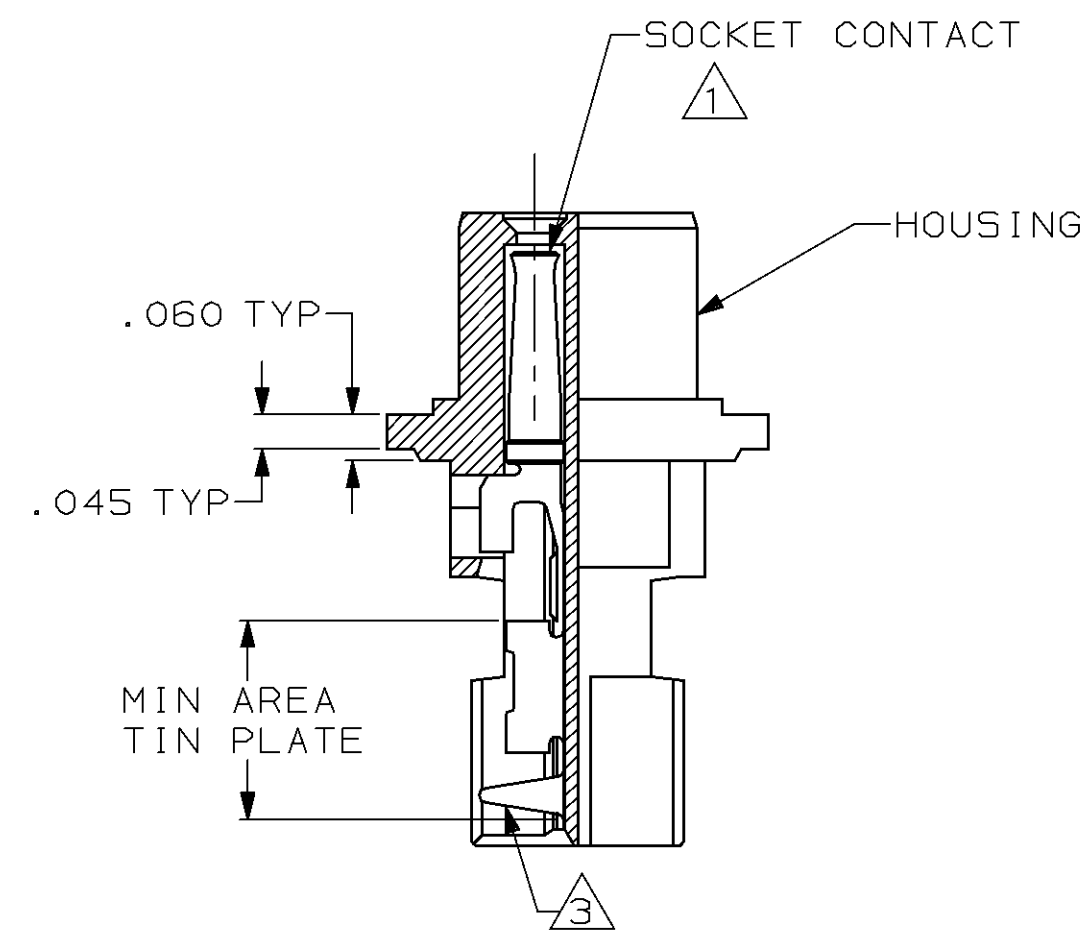
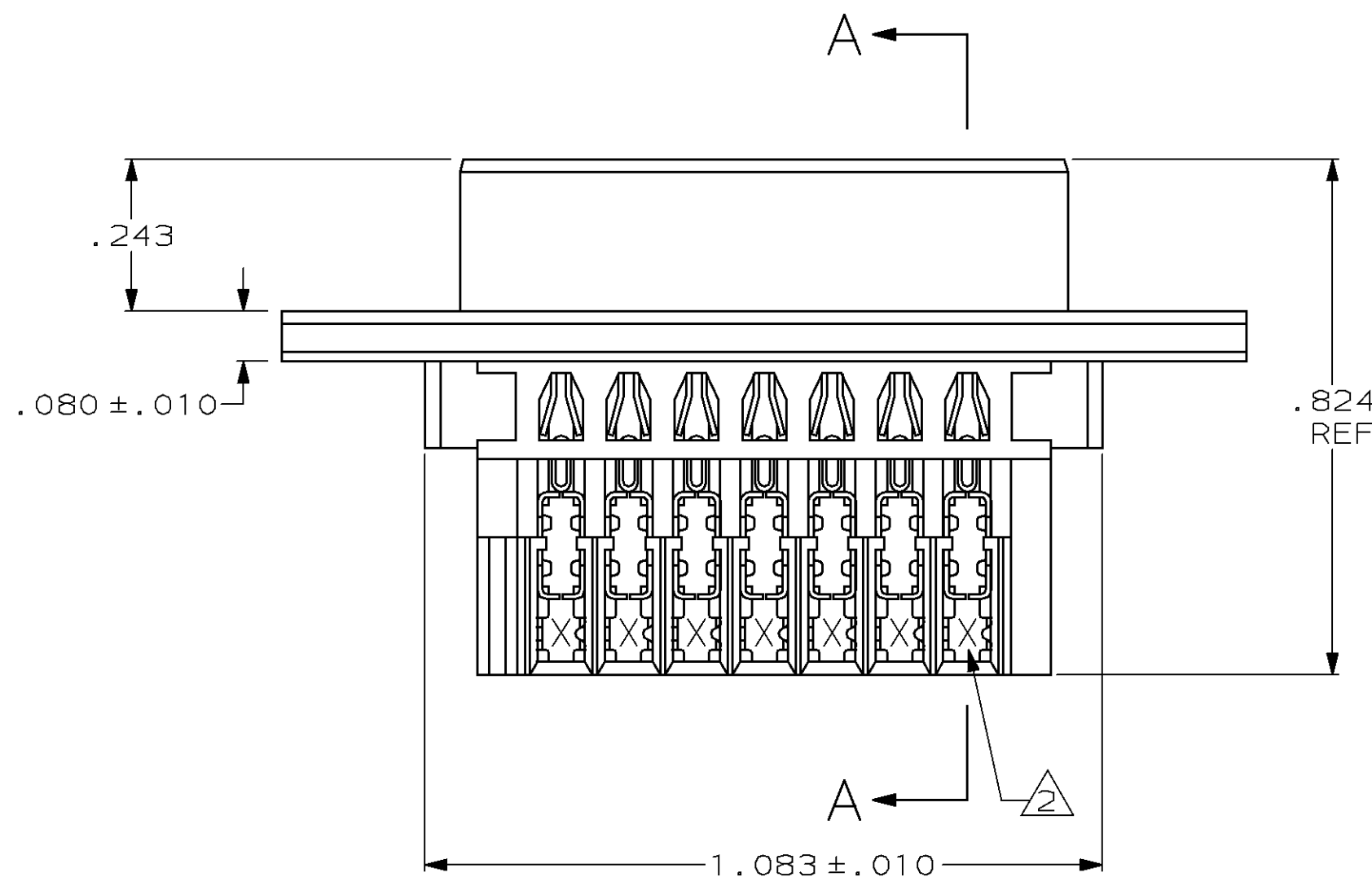
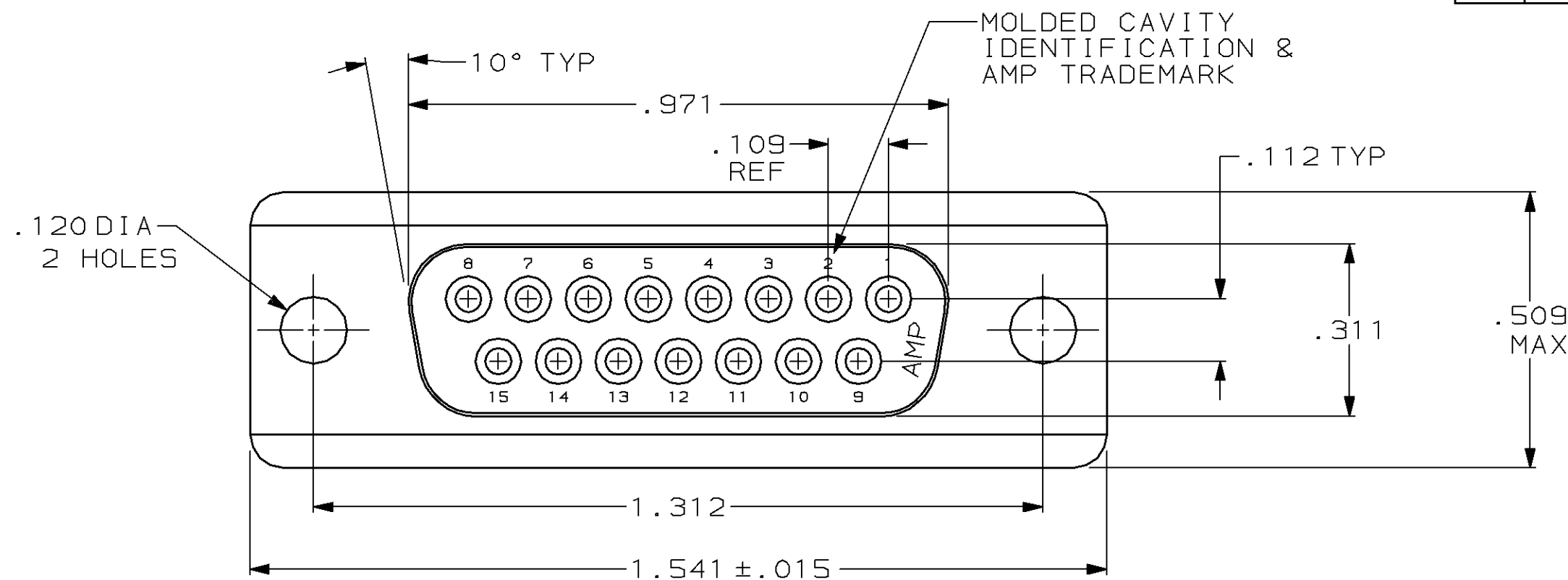

SECTION A-A

- ① HOUSING FULLY LOADED WITH CONTACTS.
- ② NUMBER ON CONTACT INDICATES WIRE RANGE.
- ③ CONTACT INSULATION RANGE: .060 MAXIMUM O.D.
- ④ CONTACTS PLATED .000030 GOLD ON MATING END FOR .100 MIN LENGTH. .000100-.000200 THICK BRIGHT TIN OR BRIGHT TIN-LEAD IN AREA SHOWN. .000050 THICK NICKEL UNDERPLATE ON ENTIRE CONTACT.
- ⑤ CONTACTS PLATED WITH GOLD FLASH ON MATING END FOR .100 MIN LENGTH. .000100-.000200 THICK BRIGHT TIN OR BRIGHT TIN-LEAD IN AREA SHOWN. .000030 THICK NICKEL UNDERPLATE ON ENTIRE CONTACT.

OBSOLETE	⑤	3	#20-22	745205-6
		2	#22-26	745205-5
OBSOLETE	④	1	#26-30	745205-4
		3	#20-22	745205-3
	③	2	#22-26	745205-2
		1	#26-30	745205-1
FINISH	②	AWG WIRE RANGE	PART NUMBER	

DO NOT SCALE PRINT. UNLESS SPECIFIED DIMENSIONS IN INCHES TOLERANCES ON: 2 PLC DEC ± - 3 PLC DEC ± .005 ANGLES ± 2°	DR 4-9-90 J.GALLUCCI BG CHK 6-21-90 W.LENKER APPD 6-22-90 J.WESTMAN	AMP INCORPORATED Harrisburg, Pa. 17105		
MATERIAL HOUSING: BLACK THERMOPLASTIC 94V-0 RATED CONTACTS: PHOSPHOR BRONZE	APPD 6-22-90 J.ASSINI PRODUCT SPEC 108-40011			NAME RECEPTACLE ASSEMBLY, SIZE 2, 15 POSITION, AMPLIMITE™
FINISH SEE TABLE	APPLICATION SPEC 114-40002	SIZE C	FSCM NO 00779	DRAWING NO 745205
	WEIGHT -	SCALE 4:1		SHEET 1 OF 1