



# 1 Mbit (128K x 8/64K x 16) nvSRAM with Real Time Clock

## Features

- 1 Mbit nvSRAM
  - 20 ns, 25 ns, and 45 ns access times
  - Internally organized as 128K x 8 (CY14B101KA) or 64K x 16 (CY14B101MA)
  - Hands off automatic STORE on power down with only a small capacitor
  - STORE to QuantumTrap nonvolatile elements is initiated by software, hardware, or AutoStore on power down
  - RECALL to SRAM initiated on power up or by software
- High Reliability
  - Infinite Read, Write, and RECALL cycles
  - 200,000 STORE cycles to QuantumTrap
  - 20 year data retention
- Real Time Clock
  - Full featured Real Time Clock
  - Watchdog timer
  - Clock alarm with programmable interrupts
  - Capacitor or battery backup for RTC
  - Backup current of 300 nA

## Industry Standard Configurations

- Single 3V +20%, -10% operation
- Commercial and Industrial temperatures
- 44-pin and 54-pin TSOP II and 48-pin SSOP packages
- Pb-free and RoHS compliance

## Functional Description

The Cypress CY14B101KA/CY14B101MA combines a 1 Mbit nonvolatile static RAM with a full featured real time clock in a monolithic integrated circuit. The embedded nonvolatile elements incorporate QuantumTrap technology producing the world's most reliable nonvolatile memory. The SRAM is read and written an infinite number of times, while independent nonvolatile data resides in the nonvolatile elements.

The Real Time Clock function provides an accurate clock with leap year tracking and a programmable, high accuracy oscillator. The alarm function is programmable for periodic minutes, hours, days, or months alarms. There is also a programmable watchdog timer for process control.

## Logic Block Diagram<sup>[1, 2, 3]</sup>

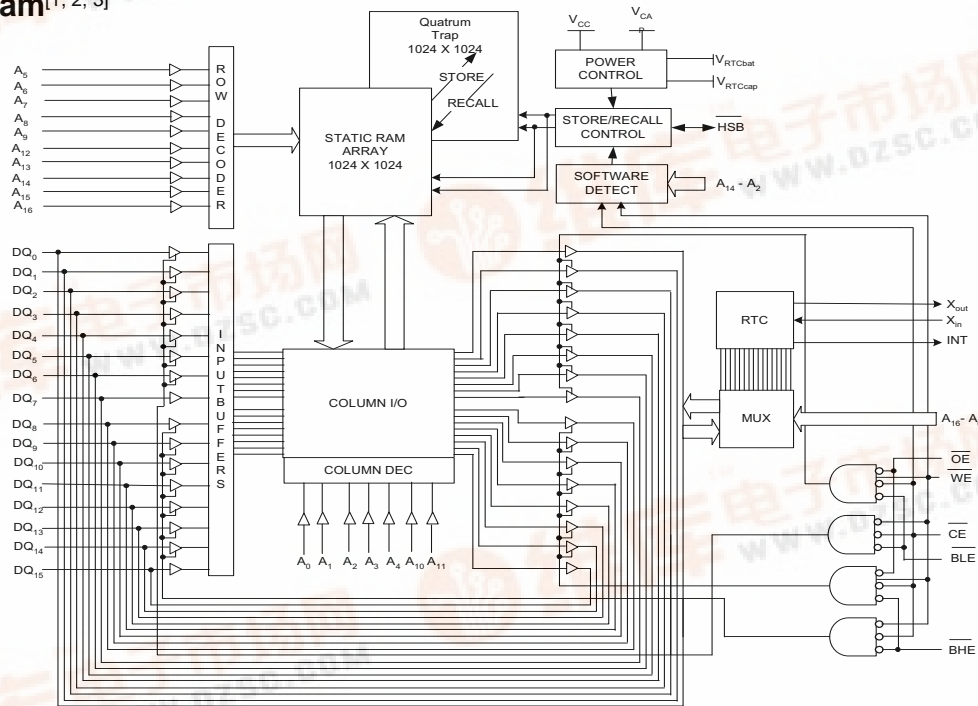

### Notes

1. Address A<sub>0</sub> - A<sub>16</sub> for x8 configuration and Address A<sub>0</sub> - A<sub>15</sub> for x16 configuration.
2. Data DQ<sub>0</sub> - DQ<sub>7</sub> for x8 configuration and Data DQ<sub>0</sub> - DQ<sub>15</sub> for x16 configuration.
3. BHE and BLE are applicable for x16 configuration only.





## Pin Definitions (continued)

| Pin Name                | I/O Type     | Description  |
|-------------------------|--------------|--|
| INT                     | Output       | <b>Interrupt Output.</b> Programmable to respond to the clock alarm, the watchdog timer, and the power monitor. Also programmable to either active HIGH (push or pull) or LOW (open drain).  |
| V <sub>SS</sub>         | Ground       | <b>Ground for the Device.</b> Must be connected to the ground of the system.   |
| V <sub>CC</sub>         | Power Supply | <b>Power Supply Inputs to the Device.</b> 3.0V +20%, -10%  |
| $\overline{\text{HSB}}$ | Input/Output | <b>Hardware STORE Busy (HSB).</b> When LOW this output indicates that a Hardware STORE is in progress. When pulled LOW external to the chip, it initiates a nonvolatile STORE operation. A weak internal pull up resistor keeps this pin HIGH if not connected (connection optional). After each STORE operation, HSB is driven HIGH for short time with standard output high current. |
| V <sub>CAP</sub>        | Power Supply | <b>AutoStore Capacitor.</b> Supplies power to the nvSRAM during power loss to store data from SRAM to nonvolatile elements.  |

## Device Operation

The CY14B101KA/CY14B101MA nvSRAM is made up of two functional components paired in the same physical cell. These are a SRAM memory cell and a nonvolatile QuantumTrap cell. The SRAM memory cell operates as a standard fast static RAM. Data in the SRAM is transferred to the nonvolatile cell (the STORE operation), or from the nonvolatile cell to the SRAM (the RECALL operation). Using this unique architecture, all cells are stored and recalled in parallel. During the STORE and RECALL operations SRAM read and write operations are inhibited. The CY14B101KA/CY14B101MA supports infinite reads and writes similar to a typical SRAM. In addition, it provides infinite RECALL operations from the nonvolatile cells and up to 200K STORE operations. Refer the [Truth Table For SRAM Operations](#) on page 23 for a complete description of read and write modes.

## SRAM Read

The CY14B101KA/CY14B101MA performs a read cycle whenever CE and OE are LOW, and WE and HSB are HIGH. The address specified on pins A<sub>0-16</sub> or A<sub>0-15</sub> determines which of the 131,072 data bytes or 65,536 words of 16 bits each are accessed. Byte enables (BHE, BLE) determine which bytes are enabled to the output, in the case of 16-bit words. When the read is initiated by an address transition, the outputs are valid after a delay of t<sub>AA</sub> (read cycle #1). If the read is initiated by CE or OE, the outputs are valid at t<sub>ACE</sub> or at t<sub>DOE</sub>, whichever is later (read cycle #2). The data output repeatedly responds to address changes within the t<sub>AA</sub> access time without the need for transitions on any control input pins. This remains valid until another address change or until CE or OE is brought HIGH, or WE or HSB is brought LOW.

## SRAM Write

A write cycle is performed when  $\overline{\text{CE}}$  and  $\overline{\text{WE}}$  are LOW and  $\overline{\text{HSB}}$  is HIGH. The address inputs must be stable before entering the write cycle and must remain stable until CE or WE goes HIGH at the end of the cycle. The data on the common I/O pins IO<sub>0-7</sub> are written into the memory if it is valid t<sub>SD</sub> before the end of a WE-controlled write, or before the end of a CE-controlled write. The Byte Enable inputs (BHE, BLE) determine which bytes are written, in the case of 16-bit words. It is recommended that OE be kept HIGH during the entire write cycle to avoid data bus contention on common I/O lines. If OE is left LOW, internal circuitry turns off the output buffers t<sub>HZWE</sub> after WE goes LOW.

## AutoStore Operation

The CY14B101KA/CY14B101MA stores data to the nvSRAM using one of three storage operations. These three operations are: Hardware STORE, activated by the HSB; Software STORE, activated by an address sequence; AutoStore, on device power down. The AutoStore operation is a unique feature of QuantumTrap technology and is enabled by default on the CY14B101KA/CY14B101MA.

During normal operation, the device draws current from V<sub>CC</sub> to charge a capacitor connected to the V<sub>CAP</sub> pin. This stored charge is used by the chip to perform a single STORE operation. If the voltage on the V<sub>CC</sub> pin drops below V<sub>SWITCH</sub>, the part automatically disconnects the V<sub>CAP</sub> pin from V<sub>CC</sub>. A STORE operation is initiated with power provided by the V<sub>CAP</sub> capacitor.

**Note** If the capacitor is not connected to V<sub>CAP</sub> pin, AutoStore must be disabled using the soft sequence specified in [Preventing AutoStore](#) on page 5. In case AutoStore is enabled without a capacitor on V<sub>CAP</sub> pin, the device attempts an AutoStore operation without sufficient charge to complete the Store. This may corrupt the data stored in nvSRAM.

Figure 2. AutoStore Mode

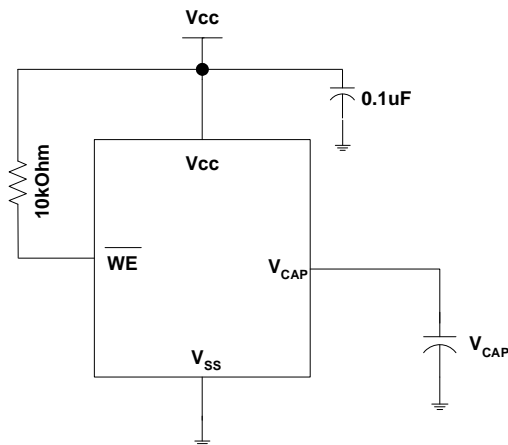

Figure 2 shows the proper connection of the storage capacitor (V<sub>CAP</sub>) for automatic STORE operation. Refer to [DC Electrical Characteristics](#) on page 15 for the size of the V<sub>CAP</sub>. The voltage on the V<sub>CAP</sub> pin is driven to V<sub>CC</sub> by a regulator on the chip. Place

a pull up on  $\overline{WE}$  to hold it inactive during power up. This pull up is only effective if the WE signal is tristate during power up. Many MPUs tristate their controls on power up. This must be Verified when using the pull up. When the nvSRAM comes out of power-on-recall, the MPU must be active or the  $\overline{WE}$  held inactive until the MPU comes out of reset.

To reduce unnecessary nonvolatile stores, AutoStore and Hardware STORE operations are ignored unless at least one write operation has taken place since the most recent STORE or RECALL cycle. Software initiated STORE cycles are performed regardless of whether a write operation has taken place.

The HSB signal is monitored by the system to detect if an AutoStore cycle is in progress.

## Hardware STORE ( $\overline{HSB}$ ) Operation

The CY14B101KA/CY14B101MA provides the  $\overline{HSB}$  pin to control and acknowledge the STORE operations. The  $\overline{HSB}$  pin is used to request a Hardware STORE cycle. When the HSB pin is driven LOW, the CY14B101KA/CY14B101MA conditionally initiates a STORE operation after  $t_{DELAY}$ . An actual STORE cycle begins only if a write to the SRAM has taken place since the last STORE or RECALL cycle. The HSB pin also acts as an open drain driver that is internally driven LOW to indicate a busy condition when the STORE (initiated by any means) is in progress.

SRAM write operations that are in progress when  $\overline{HSB}$  is driven LOW by any means are given time ( $t_{DELAY}$ ) to complete before the STORE operation is initiated. However, any SRAM write cycles requested after HSB goes LOW are inhibited until HSB returns HIGH. In case the write latch is not set,  $\overline{HSB}$  is not driven LOW by the CY14B101KA/CY14B101MA. But any SRAM read and write cycles are inhibited until HSB is returned HIGH by MPU or other external source.

During any STORE operation, regardless of how it is initiated, the CY14B101KA/CY14B101MA continues to drive the  $\overline{HSB}$  pin LOW, releasing it only when the STORE is complete. Upon completion of the STORE operation, the CY14B101KA/CY14B101MA remains disabled until the  $\overline{HSB}$  pin returns HIGH. Leave the HSB unconnected if it is not used.

## Hardware RECALL (Power Up)

During power up or after any low power condition ( $V_{CC} < V_{SWITCH}$ ), an internal RECALL request is latched. When  $V_{CC}$  again exceeds the  $V_{SWITCH}$  on powerup, a RECALL cycle is automatically initiated and takes  $t_{HRECALL}$  to complete. During this time, the HSB pin is driven LOW by the HSB driver and all reads and writes to nvSRAM are inhibited.

## Software STORE

Data is transferred from SRAM to the nonvolatile memory by a software address sequence. The CY14B101KA/CY14B101MA Software STORE cycle is initiated by executing sequential CE or OE controlled read cycles from six specific address locations in exact order. During the STORE cycle, an erase of the previous nonvolatile data is first performed, followed by a program of the nonvolatile elements. After a STORE cycle is initiated, further input and output are disabled until the cycle is completed.

Because a sequence of reads from specific addresses is used for STORE initiation, it is important that no other read or write accesses intervene in the sequence, or the sequence is aborted and no STORE or RECALL takes place.

To initiate the Software STORE cycle, the following read sequence must be performed:

1. Read address 0x4E38 Valid READ
2. Read address 0xB1C7 Valid READ
3. Read address 0x83E0 Valid READ
4. Read address 0x7C1F Valid READ
5. Read address 0x703F Valid READ
6. Read address 0x8FC0 Initiate STORE cycle

The software sequence may be clocked with  $\overline{CE}$  controlled reads or OE controlled reads, with  $\overline{WE}$  kept HIGH for all the six READ sequences. After the sixth address in the sequence is entered, the STORE cycle commences and the chip is disabled. HSB is driven LOW. After the  $t_{STORE}$  cycle time is fulfilled, the SRAM is activated again for the read and write operation.

## Software RECALL

Data is transferred from nonvolatile memory to the SRAM by a software address sequence. A Software RECALL cycle is initiated with a sequence of read operations in a manner similar to the Software STORE initiation. To initiate the RECALL cycle, the following sequence of CE or OE controlled read operations must be performed:

1. Read address 0x4E38 Valid READ
2. Read address 0xB1C7 Valid READ
3. Read address 0x83E0 Valid READ
4. Read address 0x7C1F Valid READ
5. Read address 0x703F Valid READ
6. Read address 0x4C63 Initiate RECALL cycle

Internally, RECALL is a two step procedure. First, the SRAM data is cleared. Next, the nonvolatile information is transferred into the SRAM cells. After the  $t_{RECALL}$  cycle time, the SRAM is again ready for read and write operations. The RECALL operation does not alter the data in the nonvolatile elements.

Table 1. Mode Selection

| $\overline{CE}$ | $\overline{WE}$ | $\overline{OE}, \overline{BHE}, \overline{BLE}^{[3]}$ | $A_{15} - A_0^{[8]}$                                     | Mode   | I/O  | Power                  |
|-----------------|-----------------|---|--|--|--|------------------------|
| H               | X               | X   | X  | Not Selected   | Output High Z  | Standby                |
| L               | H               | L   | X  | Read SRAM  | Output Data  | Active                 |
| L               | L               | X   | X  | Write SRAM   | Input Data   | Active                 |
| L               | H               | L   | 0x4E38<br>0xB1C7<br>0x83E0<br>0x7C1F<br>0x703F<br>0x8B45 | Read SRAM<br>Read SRAM<br>Read SRAM<br>Read SRAM<br>Read SRAM<br>AutoStore<br>Disable  | Output Data<br>Output Data<br>Output Data<br>Output Data<br>Output Data<br>Output Data   | Active <sup>[9]</sup>  |
| L               | H               | L   | 0x4E38<br>0xB1C7<br>0x83E0<br>0x7C1F<br>0x703F<br>0x4B46 | Read SRAM<br>Read SRAM<br>Read SRAM<br>Read SRAM<br>Read SRAM<br>AutoStore<br>Enable   | Output Data<br>Output Data<br>Output Data<br>Output Data<br>Output Data<br>Output Data   | Active <sup>[9]</sup>  |
| L               | H               | L   | 0x4E38<br>0xB1C7<br>0x83E0<br>0x7C1F<br>0x703F<br>0x8FC0 | Read SRAM<br>Read SRAM<br>Read SRAM<br>Read SRAM<br>Read SRAM<br>Nonvolatile<br>STORE  | Output Data<br>Output Data<br>Output Data<br>Output Data<br>Output Data<br>Output High Z | Active $I_{CC2}^{[9]}$ |
| L               | H               | L   | 0x4E38<br>0xB1C7<br>0x83E0<br>0x7C1F<br>0x703F<br>0x4C63 | Read SRAM<br>Read SRAM<br>Read SRAM<br>Read SRAM<br>Read SRAM<br>Nonvolatile<br>Recall | Output Data<br>Output Data<br>Output Data<br>Output Data<br>Output Data<br>Output High Z | Active <sup>[9]</sup>  |

### Preventing AutoStore

The AutoStore function is disabled by initiating an AutoStore disable sequence. A sequence of read operations is performed in a manner similar to the Software STORE initiation. To initiate the AutoStore disable sequence, the following sequence of  $\overline{CE}$  or  $\overline{OE}$  controlled read operations must be performed:

1. Read address 0x4E38 Valid READ
2. Read address 0xB1C7 Valid READ
3. Read address 0x83E0 Valid READ
4. Read address 0x7C1F Valid READ
5. Read address 0x703F Valid READ
6. Read address 0x8B45 AutoStore Disable

The AutoStore is reenabled by initiating an AutoStore enable sequence. A sequence of read operations is performed in a manner similar to the Software RECALL initiation.

To initiate the AutoStore enable sequence, the following sequence of  $\overline{CE}$  or  $\overline{OE}$  controlled read operations must be performed:

1. Read address 0x4E38 Valid READ
2. Read address 0xB1C7 Valid READ
3. Read address 0x83E0 Valid READ
4. Read address 0x7C1F Valid READ
5. Read address 0x703F Valid READ
6. Read address 0x4B46 AutoStore Enable

If the AutoStore function is disabled or reenabled, a manual STORE operation (Hardware or Software) issued to save the AutoStore state through subsequent power down cycles. The part comes from the factory with AutoStore enabled.

### Notes

8. While there are 17 address lines on the CY14B101KA (16 address lines on the CY14B101MA), only the 13 address lines ( $A_{14} - A_2$ ) are used to control software modes. The remaining address lines are don't care.
9. The six consecutive address locations must be in the order listed.  $\overline{WE}$  must be HIGH during all six cycles to enable a nonvolatile cycle.

## Best Practices

nvSRAM products have been used effectively for over 15 years. While ease-of-use is one of the product's main system values, experience gained working with hundreds of applications has resulted in the following suggestions as best practices:

- The nonvolatile cells in this nvSRAM product are delivered from Cypress with 0x00 written in all cells. Incoming inspection routines at customer or contract manufacturer's sites sometimes reprogram these values. Final NV patterns are typically repeating patterns of AA, 55, 00, FF, A5, or 5A. End product's firmware should not assume an NV array is in a set programmed state. Routines that check memory content values to determine first time system configuration, cold or warm boot status, and so on should always program a unique NV pattern (that is, complex 4-byte pattern of 46 E6 49 53 hex

or more random bytes) as part of the final system manufacturing test to ensure these system routines work consistently.

- Power up boot firmware routines should rewrite the nvSRAM into the desired state (for example, autostore enabled). While the nvSRAM is shipped in a preset state, best practice is to again rewrite the nvSRAM into the desired state as a safeguard against events that might flip the bit inadvertently such as program bugs and incoming inspection routines.
- The  $V_{CAP}$  value specified in this data sheet includes a minimum and a maximum value size. Best practice is to meet this requirement and not exceed the maximum  $V_{CAP}$  value because the nvSRAM internal algorithm calculates  $V_{CAP}$  charge and discharge time based on this max  $V_{CAP}$  value. Customers that want to use a larger  $V_{CAP}$  value to make sure there is extra store charge and store time should discuss their  $V_{CAP}$  size selection with Cypress to understand any impact on the  $V_{CAP}$  voltage level at the end of a  $t_{RECALL}$  period.

## Data Protection

The CY14B101KA/CY14B101MA protects data from corruption during low voltage conditions by inhibiting all externally initiated STORE and write operations. The low voltage condition is detected when  $V_{CC}$  is less than  $V_{SWITCH}$ . If the CY14B101KA/CY14B101MA is in a write mode (both CE and WE are LOW) at power up, after a RECALL or STORE, the write is inhibited until the SRAM is enabled after  $t_{LZHSB}$  (HSB to output active). This protects against inadvertent writes during power up or brown out conditions.

## Noise Considerations

Refer to CY application note [AN1064](#).

## Real Time Clock Operation

### nvTIME Operation

The CY14B101KA/CY14B101MA offers internal registers that contain clock, alarm, watchdog, interrupt, and control functions. Internal double buffering of the clock and timer information registers prevents accessing transitional internal clock data during a read or write operation. Double buffering also circumvents disrupting normal timing counts or the clock accuracy of the internal clock when accessing clock data. Clock and alarm registers store data in BCD format.

RTC functionality is described with respect to CY14B101KA in the following sections. The same description applies to CY14B101MA, except for the RTC register addresses. The RTC register addresses for CY14B101KA range from 0x1FFF0 to 0x1FFFF, while those for CY14B101MA range from 0x0FFF0 to 0x0FFFF. Refer to [Table 3](#) on page 11 and [Table 4](#) on page 12 for a detailed Register Map description.

### Clock Operations

The clock registers maintain time up to 9,999 years in one second increments. The time can be set to any calendar time and the clock automatically keeps track of days of the week and month, leap years, and century transitions. There are eight registers dedicated to the clock functions, which are used to set time with a write cycle and to read time during a read cycle. These registers contain the time of day in BCD format. Bits defined as '0' are currently not used and are reserved for future use by Cypress.

### Reading the Clock

The double buffered RTC register structure reduces the chance of reading incorrect data from the clock. Stop internal updates to the CY14B101KA time keeping registers before reading clock data, to prevent reading of data in transition. Stopping the register updates does not affect clock accuracy.

The updating process is stopped by writing a '1' to the read bit 'R' (in the flags register at 0x1FFF0), and does not restart until a '0' is written to the read bit. The RTC registers are then read while the internal clock continues to run. After a '0' is written to the read bit ('R'), all RTC registers are simultaneously updated within 20 ms.

## Setting the Clock

Setting the write bit 'W' (in the flags register at 0x1FFF0) to a '1' stops updates to the time keeping registers and enables the time to be set. The correct day, date, and time is then written into the registers and must be in 24-hour BCD format. The time written is referred to as the "Base Time". This value is stored in nonvolatile registers and used in the calculation of the current time. Resetting the write bit to '0' transfers the values of timekeeping registers to the actual clock counters, after which the clock resumes normal operation.

If the time written to the timekeeping registers is not in the correct BCD format, each invalid nibble of the RTC registers continue counting to 0xF before rolling over to 0x0 after which RTC resumes normal operation.

**Note** The values entered in the timekeeping, alarm, calibration, and interrupt registers need a STORE operation to be saved in nonvolatile memory. Therefore, while working in AutoStore disabled mode, the user must perform a STORE operation after writing into the RTC registers for the RTC to work correctly.

## Backup Power

The RTC in the CY14B101KA is intended for permanently powered operation. The  $V_{RTCcap}$  or  $V_{RTCbat}$  pin is connected depending on whether a capacitor or battery is chosen for the application. When the primary power,  $V_{CC}$ , fails and drops below  $V_{SWITCH}$  the device switches to the backup power supply.

The clock oscillator uses very little current, which maximizes the backup time available from the backup source. Regardless of the clock operation with the primary source removed, the data stored in the nvSRAM is secure, having been stored in the nonvolatile elements when power was lost.

During backup operation, the CY14B101KA consumes a maximum of 300 nanoamps at room temperature. The user must choose capacitor or battery values according to the application.

Backup time values based on maximum current specifications are shown in the following table. Nominal backup times are approximately two times longer.

**Table 2. RTC Backup Time**

| Capacitor Value | Backup Time |
|-----------------|-------------|
| 0.1F            | 72 hours    |
| 0.47F           | 14 days     |
| 1.0F            | 30 days     |

Using a capacitor has the obvious advantage of recharging the backup source each time the system is powered up. If a battery is used, a 3V lithium is recommended and the CY14B101KA sources current only from the battery when the primary power is removed. However, the battery is not recharged at any time by the CY14B101KA. The battery capacity must be chosen for total anticipated cumulative down time required over the life of the system.

## Stopping and Starting the Oscillator

The OSCEN bit in the calibration register at 0x1FFF8 controls the enable and disable of the oscillator. This bit is nonvolatile and is shipped to customers in the “enabled” (set to 0) state. To preserve the battery life when the system is in storage, OSCEN must be set to ‘1’. This turns off the oscillator circuit, extending the battery life. If the OSCEN bit goes from disabled to enabled, it takes approximately one second (two seconds maximum) for the oscillator to start.

While system power is off, if the voltage on the backup supply ( $V_{RTCcap}$  or  $V_{RTCbat}$ ) falls below their respective minimum level, the oscillator may fail. The CY14B101KA has the ability to detect oscillator failure when system power is restored. This is recorded in the OSCF (Oscillator Failed bit) of the flags register at the address 0x1FFF0. When the device is powered on ( $V_{CC}$  goes above  $V_{SWITCH}$ ) the OSCEN bit is checked for “enabled” status. If the OSCEN bit is enabled and the oscillator is not active within the first 5 ms, the OSCF bit is set to “1”. The system must check for this condition and then write ‘0’ to clear the flag. Note that in addition to setting the OSCF flag bit, the time registers are reset to the “Base Time” (see [Setting the Clock](#) on page 7), which is the value last written to the timekeeping registers. The control or calibration registers and the OSCEN bit are not affected by the ‘oscillator failed’ condition.

Reset the value of OSCF to ‘0’ when the time registers are written for the first time. This initializes the state of this bit which may have become set when the system was first powered on.

To reset OSCF, set the write bit “W” (in the Flags register at 0x1FFF0) to a “1” to enable writes to the Flag register. Write a “0” to the OSCF bit and reset the write bit to “0” to disable writes.

## Calibrating the Clock

The RTC is driven by a quartz controlled crystal with a nominal frequency of 32.768 kHz. Clock accuracy depends on the quality of the crystal and calibration. The crystals available in market typically have an error of  $\pm 20$  ppm to  $\pm 35$  ppm. However, CY14B101KA employs a calibration circuit that improves the accuracy to  $+1/-2$  ppm at 25°C. This implies an error of  $+2.5$  seconds to  $-5$  seconds per month.

The calibration circuit adds or subtracts counts from the oscillator divider circuit to achieve this accuracy. The number of pulses that are suppressed (subtracted, negative calibration) or split (added, positive calibration) depends upon the value loaded into the five calibration bits found in Calibration register at 0x1FFF8. The calibration bits occupy the five lower order bits in the Calibration register. These bits are set to represent any value between ‘0’ and 31 in binary form. Bit D5 is a sign bit, where a ‘1’ indicates positive calibration and a ‘0’ indicates negative calibration. Adding counts speeds the clock up and subtracting counts slows the clock down. If a binary ‘1’ is loaded into the register, it corresponds to an adjustment of 4.068 or  $-2.034$  ppm offset in oscillator error, depending on the sign.

Calibration occurs within a 64-minute cycle. The first 62 minutes in the cycle may, once per minute, have one second shortened by 128 or lengthened by 256 oscillator cycles. If a binary ‘1’ is loaded into the register, only the first two minutes of the 64-minute cycle are modified. If a binary 6 is loaded, the first 12 are affected, and so on. Therefore, each calibration step has the effect of adding 512 or subtracting 256 oscillator cycles for every

125,829,120 actual oscillator cycles, that is, 4.068 or  $-2.034$  ppm of adjustment per calibration step in the Calibration register.

To determine the required calibration, the CAL bit in the Flags register (0x1FFF0) must be set to ‘1’. This causes the INT pin to toggle at a nominal frequency of 512 Hz. Any deviation measured from the 512 Hz indicates the degree and direction of the required correction. For example, a reading of 512.01024 Hz indicates a  $+20$  ppm error. Hence, a decimal value of  $-10$  (001010b) must be loaded into the Calibration register to offset this error.

**Note** Setting or changing the Calibration register does not affect the test output frequency.

To set or clear CAL, set the write bit “W” (in the flags register at 0x1FFF0) to “1” to enable writes to the Flag register. Write a value to CAL, and then reset the write bit to “0” to disable writes.

## Alarm

The alarm function compares user programmed values of alarm time and date (stored in the registers 0x1FFF1-5) with the corresponding time of day and date values. When a match occurs, the alarm internal flag (AF) is set and an interrupt is generated on INT pin if Alarm Interrupt Enable (AIE) bit is set.

There are four alarm match fields - date, hours, minutes, and seconds. Each of these fields has a match bit that is used to determine if the field is used in the alarm match logic. Setting the match bit to ‘0’ indicates that the corresponding field is used in the match process. Depending on the match bits, the alarm occurs as specifically as once a month or as frequently as once every minute. Selecting none of the match bits (all 1s) indicates that no match is required and therefore, alarm is disabled. Selecting all match bits (all 0s) causes an exact time and date match.

There are two ways to detect an alarm event: by reading the AF flag or monitoring the INT pin. The AF flag in the flags register at 0x1FFF0 indicates that a date or time match has occurred. The AF bit is set to “1” when a match occurs. Reading the flags register clears the alarm flag bit (and all others). A hardware interrupt pin may also be used to detect an alarm event.

To set, clear or enable an alarm, set the ‘W’ bit (in Flags Register - 0x1FFF0) to ‘1’ to enable writes to Alarm Registers. After writing the alarm value, clear the ‘W’ bit back to “0” for the changes to take effect.

**Note** CY14B101KA requires the alarm match bit for seconds (0x1FFF2 - D7) to be set to ‘0’ for proper operation of Alarm Flag and Interrupt.

## Watchdog Timer

The Watchdog Timer is a free running down counter that uses the 32 Hz clock (31.25 ms) derived from the crystal oscillator. The oscillator must be running for the watchdog to function. It begins counting down from the value loaded in the Watchdog Timer register.

The timer consists of a loadable register and a free running counter. On power up, the watchdog time out value in register 0x1FFF7 is loaded into the Counter Load register. Counting begins on power up and restarts from the loadable value any time the Watchdog Strobe (WDS) bit is set to ‘1’. The counter is compared to the terminal value of ‘0’. If the counter reaches this



value, it causes an internal flag and an optional interrupt output. You can prevent the time out interrupt by setting WDS bit to '1' prior to the counter reaching '0'. This causes the counter to reload with the watchdog time out value and to be restarted. As long as the user sets the WDS bit prior to the counter reaching the terminal value, the interrupt and WDT flag never occur.

New time out values are written by setting the watchdog write bit to '0'. When the WDW is '0', new writes to the watchdog time out value bits D5-D0 are enabled to modify the time out value. When WDW is '1', writes to bits D5-D0 are ignored. The WDW function enables a user to set the WDS bit without concern that the watchdog timer value is modified. A logical diagram of the watchdog timer is shown in Figure 3. Note that setting the watchdog time out value to '0' disables the watchdog function.

The output of the watchdog timer is the flag bit WDF that is set if the watchdog is allowed to time out. If the Watchdog Interrupt Enable (WIE) bit in the Interrupt register is set, a hardware interrupt on INT pin is also generated on watchdog timeout. The flag and the hardware interrupt are both cleared when user reads the Flags registers.

Figure 3. Watchdog Timer Block Diagram

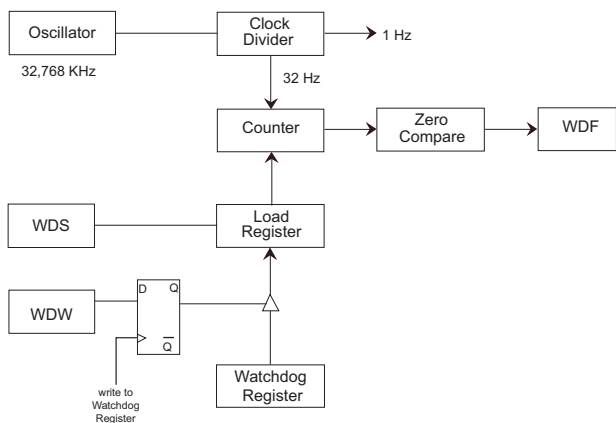

## Power Monitor

The CY14B101KA provides a power management scheme with power fail interrupt capability. It also controls the internal switch to backup power for the clock and protects the memory from low  $V_{CC}$  access. The power monitor is based on an internal band gap reference circuit that compares the  $V_{CC}$  voltage to  $V_{SWITCH}$  threshold.

As described in the [AutoStore Operation](#) on page 3, when  $V_{SWITCH}$  is reached as  $V_{CC}$  decays from power loss, a data STORE operation is initiated from SRAM to the nonvolatile elements, securing the last SRAM data state. Power is also switched from  $V_{CC}$  to the backup supply (battery or capacitor) to operate the RTC oscillator.

When operating from the backup source, read and write operations to nvSRAM are inhibited and the clock functions are not available to the user. The clock continues to operate in the background. The updated clock data is available to the user  $t_{HRECALL}$  delay after  $V_{CC}$  is restored to the device (see [AutoStore/Power Up RECALL](#) on page 20).

## Interrupts

The CY14B101KA has Flags register, Interrupt register and Interrupt logic that can signal interrupt to the microcontroller. There are three potential sources for interrupt: watchdog timer, power monitor, and alarm timer. Each of these can be individually enabled to drive the INT pin by appropriate setting in the Interrupt register (0x1FFF6). In addition, each has an associated flag bit in the Flags register (0x1FFF0) that the host processor uses to determine the cause of the interrupt. The INT pin driver has two bits that specify its behavior when an interrupt occurs.

An Interrupt is raised only if both a flag is raised by one of the three sources and the respective interrupt enable bit in Interrupts register is enabled (set to '1'). After an interrupt source is active, two programmable bits, H/L and P/L, determine the behavior of the output pin driver on INT pin. These two bits are located in the Interrupt register and can be used to drive level or pulse mode output from the INT pin. In pulse mode, the pulse width is internally fixed at approximately 200 ms. This mode is intended to reset a host microcontroller. In the level mode, the pin goes to its active polarity until the Flags register is read by the user. This mode is used as an interrupt to a host microcontroller. The control bits are summarized in the following section.

Interrupts are only generated while working on normal power and are not triggered when system is running in backup power mode.

**Note** CY14B101KA generates valid interrupts only after the Powerup Recall sequence is completed. All events on INT pin must be ignored for  $t_{HRECALL}$  duration after powerup.

### Interrupt Register

**Watchdog Interrupt Enable - WIE.** When set to '1', the watchdog timer drives the INT pin and an internal flag when a watchdog time out occurs. When WIE is set to '0', the watchdog timer only affects the WDF flag in Flags register.

**Alarm Interrupt Enable - AIE.** When set to '1', the alarm match drives the INT pin and an internal flag. When AIE is set to '0', the alarm match only affects the AF Flag in Flags register.

**Power Fail Interrupt Enable - PFE.** When set to '1', the power fail monitor drives the pin and an internal flag. When PFE is set to '0', the power fail monitor only affects the PF flag in Flags register.

**High/Low - H/L.** When set to a '1', the INT pin is active HIGH and the driver mode is push pull. The INT pin drives high only when  $V_{CC}$  is greater than  $V_{SWITCH}$ . When set to a '0', the INT pin is active LOW and the drive mode is open drain. The INT pin must be pulled up to  $V_{CC}$  by a 10k resistor while using the interrupt in active LOW mode.

**Pulse/Level - P/L.** When set to a '1' and an interrupt occurs, the INT pin is driven for approximately 200 ms. When P/L is set to a '0', the INT pin is driven high or low (determined by H/L) until the Flags or Control register is read.

When an enabled interrupt source activates the INT pin, an external host reads the Flags registers to determine the cause. All flags are cleared when the register is read. If the INT pin is programmed for Level mode, then the condition clears and the INT pin returns to its inactive state. If the pin is programmed for Pulse mode, then reading the flag also clears the flag and the pin. The pulse does not complete its specified duration if the Flags register is read. If the INT pin is used as a host reset, then the Flags register is not read during a reset.

### Flags Register

The Flag register has three flag bits: WDF, AF, and PF, which can be used to generate an interrupt. These flags are set by the watchdog timeout, alarm match, or power fail monitor respectively. The processor can either poll this register or enable interrupts to be informed when a flag is set. These flags are automati-

cally reset when the register is read. The flags register is automatically loaded with the value 0x00 on power up (except for the OSCF bit; see [Stopping and Starting the Oscillator](#) on page 8).

Figure 4. RTC Recommended Component Configuration

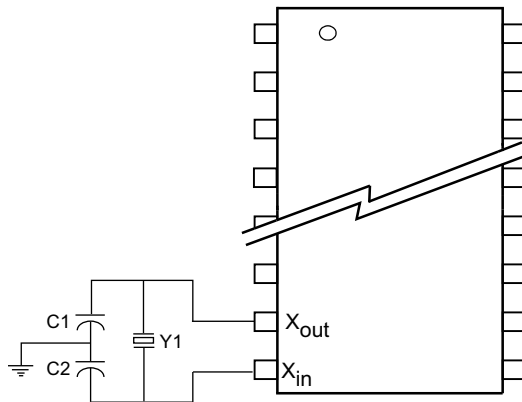

#### Recommended Values

$Y_1 = 32.768 \text{ KHz (12.5 pF)}$

$C_1 = 10 \text{ pF}$

$C_2 = 67 \text{ pF}$

**Note:** The recommended values for C1 and C2 include board trace capacitance.

Figure 5. Interrupt Block Diagram

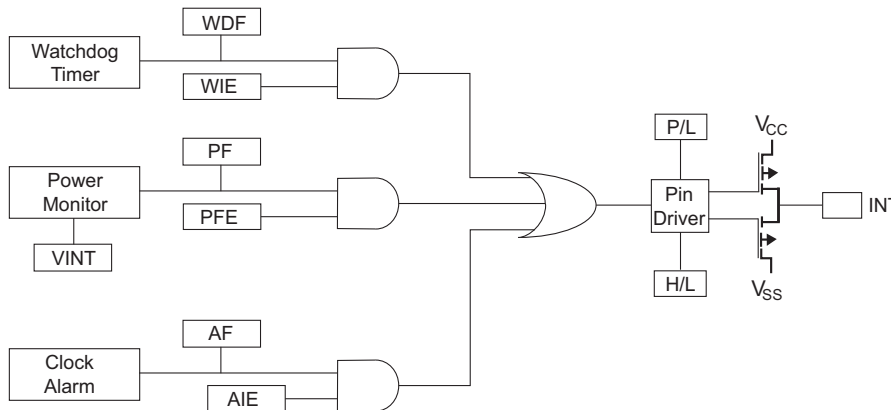

WDF - Watchdog Timer Flag  
 WIE - Watchdog Interrupt Enable  
 PF - Power Fail Flag  
 PFE - Power Fail Enable  
 AF - Alarm Flag  
 AIE - Alarm Interrupt Enable  
 P/L - Pulse Level  
 H/L - High/Low

Table 3. RTC Register Map<sup>[10, 11, 12]</sup>

| Register   |            | BCD Format Data <sup>[11]</sup> |                  |                  |                     |                |             |       |       | Function/Range                     |
|------------|------------|---------------------------------|------------------|------------------|---------------------|----------------|-------------|-------|-------|------------------------------------|
| CY14B101KA | CY14B101MA | D7                              | D6               | D5               | D4                  | D3             | D2          | D1    | D0    |                                    |
| 0x1FFFF    | 0x0FFFF    | 10s Years                       |                  |                  |                     | Years          |             |       |       | Years: 00–99                       |
| 0x1FFFE    | 0x0FFE     | 0                               | 0                | 0                | 10s Months          | Months         |             |       |       | Months: 01–12                      |
| 0x1FFFD    | 0x0FFFD    | 0                               | 0                | 10s Day of Month |                     | Day Of Month   |             |       |       | Day of Month: 01–31                |
| 0x1FFFC    | 0x0FFFC    | 0                               | 0                | 0                | 0                   | 0              | Day of Week |       |       | Day of Week: 01–07                 |
| 0x1FFFB    | 0x0FFB     | 0                               | 0                | 10s Hours        |                     |                | Hours       |       |       | Hours: 00–23                       |
| 0x1FFFA    | 0x0FFFA    | 0                               | 10s Minutes      |                  |                     | Minutes        |             |       |       | Minutes: 00–59                     |
| 0x1FFF9    | 0x0FFF9    | 0                               | 10s Seconds      |                  |                     | Seconds        |             |       |       | Seconds: 00–59                     |
| 0x1FFF8    | 0x0FFF8    | OSCEN (0)                       | 0                | Cal Sign (0)     | Calibration (00000) |                |             |       |       | Calibration Values <sup>[13]</sup> |
| 0x1FFF7    | 0x0FFF7    | WDS (0)                         | WDW (0)          | WDT (000000)     |                     |                |             |       |       | Watchdog <sup>[13]</sup>           |
| 0x1FFF6    | 0x0FFF6    | WIE (0)                         | AIE (0)          | PFE (0)          | 0                   | H/L (1)        | P/L (0)     | 0     | 0     | Interrupts <sup>[13]</sup>         |
| 0x1FFF5    | 0x0FFF5    | M (1)                           | 0                | 10s Alarm Date   |                     | Alarm Day      |             |       |       | Alarm, Day of Month: 01–31         |
| 0x1FFF4    | 0x0FFF4    | M (1)                           | 0                | 10s Alarm Hours  |                     | Alarm Hours    |             |       |       | Alarm, Hours: 00–23                |
| 0x1FFF3    | 0x0FFF3    | M (1)                           | 10 Alarm Minutes |                  |                     | Alarm Minutes  |             |       |       | Alarm, Minutes: 00–59              |
| 0x1FFF2    | 0x0FFF2    | M (1)                           | 10 Alarm Seconds |                  |                     | Alarm, Seconds |             |       |       | Alarm, Seconds: 00–59              |
| 0x1FFF1    | 0x0FFF1    | 10s Centuries                   |                  |                  |                     | Centuries      |             |       |       | Centuries: 00–99                   |
| 0x1FFF0    | 0x0FFF0    | WDF                             | AF               | PF               | OSCF                | 0              | CAL (0)     | W (0) | R (0) | Flags <sup>[13]</sup>              |

Notes

10. Upper byte D15-D8 (CY14B101MA) of RTC registers are reserved for future use.
11. The unused bits of RTC registers are reserved for future use and should be set to '0'.
12. ( ) designates values shipped from the factory.
13. This is a binary value, not a BCD value.



Table 4. Register Map Detail

| Register   |            | Description  |             |                  |           |              |             |    |    |
|------------|------------|--|-------------|------------------|-----------|--------------|-------------|----|----|
| CY14B101KA | CY14B101MA |  |             |                  |           |              |             |    |    |
| 0x1FFFF    | 0x0FFFF    | <b>Time Keeping - Years</b>  |             |                  |           |              |             |    |    |
|            |            | D7   | D6          | D5               | D4        | D3           | D2          | D1 | D0 |
|            |            | 10s Years  |             |                  |           | Years        |             |    |    |
|            |            | Contains the lower two BCD digits of the year. Lower nibble (four bits) contains the value for years; upper nibble (four bits) contains the value for 10s of years. Each nibble operates from 0 to 9. The range for the register is 0–99.  |             |                  |           |              |             |    |    |
| 0x1FFFE    | 0x0FFFE    | <b>Time Keeping - Months</b>   |             |                  |           |              |             |    |    |
|            |            | D7   | D6          | D5               | D4        | D3           | D2          | D1 | D0 |
|            |            | 0  | 0           | 0                | 10s Month | Months       |             |    |    |
|            |            | Contains the BCD digits of the month. Lower nibble (four bits) contains the lower digit and operates from 0 to 9; upper nibble (one bit) contains the upper digit and operates from 0 to 1. The range for the register is 1–12.  |             |                  |           |              |             |    |    |
| 0x1FFFD    | 0x0FFFD    | <b>Time Keeping - Date</b>   |             |                  |           |              |             |    |    |
|            |            | D7   | D6          | D5               | D4        | D3           | D2          | D1 | D0 |
|            |            | 0  | 0           | 10s Day of Month |           | Day of Month |             |    |    |
|            |            | Contains the BCD digits for the date of the month. Lower nibble (four bits) contains the lower digit and operates from 0 to 9; upper nibble (two bits) contains the 10s digit and operates from 0 to 3. The range for the register is 1–31. Leap years are automatically adjusted for. |             |                  |           |              |             |    |    |
| 0x1FFFC    | 0x0FFFC    | <b>Time Keeping - Day</b>  |             |                  |           |              |             |    |    |
|            |            | D7   | D6          | D5               | D4        | D3           | D2          | D1 | D0 |
|            |            | 0  | 0           | 0                | 0         | 0            | Day of Week |    |    |
|            |            | Lower nibble (three bits) contains a value that correlates to day of the week. Day of the week is a ring counter that counts from 1 to 7 then returns to 1. The user must assign meaning to the day value, because the day is not integrated with the date.                            |             |                  |           |              |             |    |    |
| 0x1FFFB    | 0x0FFFB    | <b>Time Keeping - Hours</b>  |             |                  |           |              |             |    |    |
|            |            | D7   | D6          | D5               | D4        | D3           | D2          | D1 | D0 |
|            |            | 0  | 0           | 10s Hours        |           | Hours        |             |    |    |
|            |            | Contains the BCD value of hours in 24 hour format. Lower nibble (four bits) contains the lower digit and operates from 0 to 9; upper nibble (two bits) contains the upper digit and operates from 0 to 2. The range for the register is 0–23.  |             |                  |           |              |             |    |    |
| 0x1FFFA    | 0x0FFFA    | <b>Time Keeping - Minutes</b>  |             |                  |           |              |             |    |    |
|            |            | D7   | D6          | D5               | D4        | D3           | D2          | D1 | D0 |
|            |            | 0  | 10s Minutes |                  |           | Minutes      |             |    |    |
|            |            | Contains the BCD value of minutes. Lower nibble (four bits) contains the lower digit and operates from 0 to 9; upper nibble (three bits) contains the upper minutes digit and operates from 0 to 5. The range for the register is 0–59.  |             |                  |           |              |             |    |    |
| 0x1FFF9    | 0x0FFF9    | <b>Time Keeping - Seconds</b>  |             |                  |           |              |             |    |    |
|            |            | D7   | D6          | D5               | D4        | D3           | D2          | D1 | D0 |
|            |            | 0  | 10s Seconds |                  |           | Seconds      |             |    |    |
|            |            | Contains the BCD value of seconds. Lower nibble (four bits) contains the lower digit and operates from 0 to 9; upper nibble (three bits) contains the upper digit and operates from 0 to 5. The range for the register is 0–59.  |             |                  |           |              |             |    |    |

Table 4. Register Map Detail (continued)

| Register         |            | Description   |     |                  |             |     |            |    |    |
|------------------|------------|---|-----|------------------|-------------|-----|------------|----|----|
| CY14B101KA       | CY14B101MA |   |     |                  |             |     |            |    |    |
| 0x1FFF8          | 0x0FFF8    | <b>Calibration/Control</b>  |     |                  |             |     |            |    |    |
|                  |            | D7  | D6  | D5               | D4          | D3  | D2         | D1 | D0 |
|                  |            | OSCEN   | 0   | Calibration Sign | Calibration |     |            |    |    |
| OSCEN            |            | Oscillator Enable. When set to 1, the oscillator is stopped. When set to 0, the oscillator runs. Disabling the oscillator saves battery or capacitor power during storage.  |     |                  |             |     |            |    |    |
| Calibration Sign |            | Determines if the calibration adjustment is applied as an addition (1) to or as a subtraction (0) from the time-base.   |     |                  |             |     |            |    |    |
| Calibration      |            | These five bits control the calibration of the clock.   |     |                  |             |     |            |    |    |
| 0x1FFF7          | 0x0FFF7    | <b>WatchDog Timer</b>   |     |                  |             |     |            |    |    |
|                  |            | D7  | D6  | D5               | D4          | D3  | D2         | D1 | D0 |
|                  |            | WDS   | WDW | WDT              |             |     |            |    |    |
| WDS              |            | Watchdog Strobe. Setting this bit to 1 reloads and restarts the watchdog timer. Setting the bit to 0 has no effect. The bit is cleared automatically after the watchdog timer is reset. The WDS bit is write only. Reading it always returns a 0.   |     |                  |             |     |            |    |    |
| WDW              |            | Watchdog Write Enable. Setting this bit to 1 disables any WRITE to the watchdog timeout value (D5–D0). This allows the user to set the watchdog strobe bit without disturbing the timeout value. Setting this bit to 0 allows bits D5–D0 to be written to the watchdog register when the next write cycle is complete. This function is explained in more detail in <a href="#">Watchdog Timer</a> on page 8. |     |                  |             |     |            |    |    |
| WDT              |            | Watchdog timeout selection. The watchdog timer interval is selected by the 6-bit value in this register. It represents a multiplier of the 32 Hz count (31.25 ms). The range of timeout value is 31.25 ms (a setting of 1) to 2 seconds (setting of 3 Fh). Setting the watchdog timer register to 0 disables the timer. These bits can be written only if the WDW bit was set to 0 on a previous cycle.       |     |                  |             |     |            |    |    |
| 0x1FFF6          | 0x0FFF6    | <b>Interrupt Status/Control</b>   |     |                  |             |     |            |    |    |
|                  |            | D7  | D6  | D5               | D4          | D3  | D2         | D1 | D0 |
|                  |            | WIE   | AIE | PFE              | 0           | H/L | P/L        | 0  | 0  |
| WIE              |            | Watchdog Interrupt Enable. When set to 1 and a watchdog timeout occurs, the watchdog timer drives the INT pin and the WDF flag. When set to 0, the watchdog timeout affects only the WDF flag.  |     |                  |             |     |            |    |    |
| AIE              |            | Alarm Interrupt Enable. When set to 1, the alarm match drives the INT pin and the AF flag. When set to 0, the alarm match only affects the AF flag.   |     |                  |             |     |            |    |    |
| PFE              |            | Power Fail Enable. When set to 1, the power fail monitor drives the INT pin and the PF flag. When set to 0, the power fail monitor affects only the PF flag.  |     |                  |             |     |            |    |    |
| 0                |            | Reserved for future use   |     |                  |             |     |            |    |    |
| H/L              |            | High/Low. When set to 1, the INT pin is driven active HIGH. When set to 0, the INT pin is open drain, active LOW.   |     |                  |             |     |            |    |    |
| P/L              |            | Pulse/Level. When set to 1, the INT pin is driven active (determined by H/L) by an interrupt source for approximately 200 ms. When set to 0, the INT pin is driven to an active level (as set by H/L) until the flags register is read.   |     |                  |             |     |            |    |    |
| 0x1FFF5          | 0x0FFF5    | <b>Alarm - Day</b>  |     |                  |             |     |            |    |    |
|                  |            | D7  | D6  | D5               | D4          | D3  | D2         | D1 | D0 |
|                  |            | M   | 0   | 10s Alarm Date   |             |     | Alarm Date |    |    |
|                  |            | Contains the alarm value for the date of the month and the mask bit to select or deselect the date value.   |     |                  |             |     |            |    |    |
| M                |            | Match. When this bit is set to 0, the date value is used in the alarm match. Setting this bit to 1 causes the match circuit to ignore the date value.   |     |                  |             |     |            |    |    |

Table 4. Register Map Detail (continued)

| Register   |  | Description   |    |                   |      |    |               |    |    |
|------------|--|---|----|-------------------|------|----|---------------|----|----|
| CY14B101KA | CY14B101MA   |   |    |                   |      |    |               |    |    |
| 0x1FFF4    | 0x0FFF4  | <b>Alarm - Hours</b>  |    |                   |      |    |               |    |    |
|            |  | D7  | D6 | D5                | D4   | D3 | D2            | D1 | D0 |
|            |  | M   | 0  | 10s Alarm Hours   |      |    | Alarm Hours   |    |    |
|            |  | Contains the alarm value for the hours and the mask bit to select or deselect the hours value.  |    |                   |      |    |               |    |    |
| M          |  | Match. When this bit is set to 0, the hours value is used in the alarm match. Setting this bit to 1 causes the match circuit to ignore the hours value.   |    |                   |      |    |               |    |    |
| 0x1FFF3    | 0x0FFF3  | <b>Alarm - Minutes</b>  |    |                   |      |    |               |    |    |
|            |  | D7  | D6 | D5                | D4   | D3 | D2            | D1 | D0 |
|            |  | M   | 0  | 10s Alarm Minutes |      |    | Alarm Minutes |    |    |
|            |  | Contains the alarm value for the minutes and the mask bit to select or deselect the minutes value.  |    |                   |      |    |               |    |    |
| M          |  | Match. When this bit is set to 0, the minutes value is used in the alarm match. Setting this bit to 1 causes the match circuit to ignore the minutes value.   |    |                   |      |    |               |    |    |
| 0x1FFF2    | 0x0FFF2  | <b>Alarm - Seconds</b>  |    |                   |      |    |               |    |    |
|            |  | D7  | D6 | D5                | D4   | D3 | D2            | D1 | D0 |
|            |  | M   | 0  | 10s Alarm Seconds |      |    | Alarm Seconds |    |    |
|            |  | Contains the alarm value for the seconds and the mask bit to select or deselect the seconds' value.   |    |                   |      |    |               |    |    |
| M          |  | Match. When this bit is set to 0, the seconds value is used in the alarm match. Setting this bit to 1 causes the match circuit to ignore the seconds value.   |    |                   |      |    |               |    |    |
| 0x1FFF1    | 0x0FFF1  | <b>Time Keeping - Centuries</b>   |    |                   |      |    |               |    |    |
|            |  | D7  | D6 | D5                | D4   | D3 | D2            | D1 | D0 |
|            |  | 0   | 0  | 10s Centuries     |      |    | Centuries     |    |    |
|            |  | Contains the BCD value of centuries. Lower nibble (four bits) contains the lower digit and operates from 0 to 9; upper nibble (two bits) contains the upper digit and operates from 0 to 9. The range for the register is 0-99 centuries. |    |                   |      |    |               |    |    |
| 0x1FFF0    | 0x0FFF0  | <b>Flags</b>  |    |                   |      |    |               |    |    |
|            |  | D7  | D6 | D5                | D4   | D3 | D2            | D1 | D0 |
|            |  | WDF   | AF | PF                | OSCF | 0  | CAL           | W  | R  |
| WDF        | Watchdog Timer Flag. This read only bit is set to 1 when the watchdog timer is allowed to reach 0 without being reset by the user. It is cleared to 0 when the Flags register is read or on power up.  |   |    |                   |      |    |               |    |    |
| AF         | Alarm Flag. This read only bit is set to 1 when the time and date match the values stored in the alarm registers with the match bits = 0. It is cleared when the Flags register is read or on power up.  |   |    |                   |      |    |               |    |    |
| PF         | Power Fail Flag. This read only bit is set to 1 when power falls below the power fail threshold $V_{SWITCH}$ . It is cleared to 0 when the Flags register is read or on power up.  |   |    |                   |      |    |               |    |    |
| OSCF       | Oscillator Fail Flag. Set to 1 on power up if the oscillator is enabled and not running in the first 5 ms of operation. This indicates that RTC backup power failed and clock value is no longer valid. This bit survives power cycle and is never cleared internally by the chip. The user must check for this condition and write '0' to clear this flag.                                |   |    |                   |      |    |               |    |    |
| CAL        | Calibration Mode. When set to 1, a 512 Hz square wave is output on the INT pin. When set to 0, the INT pin resumes normal operation. This bit defaults to 0 (disabled) on power up.  |   |    |                   |      |    |               |    |    |
| W          | Write Enable: Setting the W bit to 1 freezes updates of the RTC registers. The user can then write to RTC registers, Alarm registers, Calibration register, Interrupt register and Flags register. Setting the W bit to 0 transfers the contents of the RTC registers to the time keeping counters if the time is changed (a new base time is loaded). This bit defaults to 0 on power up. |   |    |                   |      |    |               |    |    |
| R          | Read Enable: Setting R bit to 1, stops clock updates to user RTC registers so that clock updates are not seen during the reading process. Set R bit to 0 to resume clock updates to the holding register. Setting this bit does not require W bit to be set to 1. This bit defaults to 0 on power up.  |   |    |                   |      |    |               |    |    |

## Maximum Ratings

Exceeding maximum ratings may impair the useful life of the device. These user guidelines are not tested.

Storage Temperature ..... -65°C to +150°C

Maximum Accumulated Storage Time

At 150°C Ambient Temperature..... 1000h

At 85°C Ambient Temperature..... 20 Years

Ambient Temperature with Power Applied.. -55°C to +150°C

Supply Voltage on  $V_{CC}$  Relative to GND ..... -0.5V to 4.1V

Voltage Applied to Outputs

in High-Z State..... -0.5V to  $V_{CC} + 0.5V$

Input Voltage..... -0.5V to  $V_{CC} + 0.5V$

Transient Voltage (<20 ns) on

Any Pin to Ground Potential ..... -2.0V to  $V_{CC} + 2.0V$

## DC Electrical Characteristics

Over the Operating Range ( $V_{CC} = 2.7V$  to  $3.6V$ )

| Parameter                 | Description   | Test Conditions   | Min            | Typ <sup>[14]</sup> | Max            | Unit    |
|---------------------------|---|---|----------------|---------------------|----------------|---------|
| $V_{CC}$                  | Power Supply Voltage  |   | 2.7            | 3.0                 | 3.6            | V       |
| $I_{CC1}$                 | Average $V_{CC}$ Current  | $t_{RC} = 20$ ns<br>$t_{RC} = 25$ ns<br>$t_{RC} = 45$ ns<br>Values obtained without output loads ( $I_{OUT} = 0$ mA)  | Commercial     |                     | 65             | mA      |
|                           |   | Industrial  |                |                     |                |         |
| $I_{CC2}$                 | Average $V_{CC}$ Current during STORE                               | All Inputs Don't Care, $V_{CC} = \text{Max}$ .<br>Average current for duration $t_{STORE}$  |                |                     | 10             | mA      |
| $I_{CC3}$ <sup>[14]</sup> | Average $V_{CC}$ Current at $t_{RC} = 200$ ns, $V_{CC}$ (Typ), 25°C | All I/P cycling at CMOS levels.<br>Values obtained without output loads ( $I_{OUT} = 0$ mA).  |                | 35                  |                | mA      |
| $I_{CC4}$                 | Average $V_{CAP}$ Current during AutoStore Cycle                    | All Inputs Don't Care, $V_{CC} = \text{Max}$ .<br>Average current for duration $t_{STORE}$  |                |                     | 5              | mA      |
| $I_{SB}$                  | $V_{CC}$ Standby Current  | $CE \geq (V_{CC} - 0.2V)$ . $V_{IN} \leq 0.2V$ or $\geq (V_{CC} - 0.2V)$ .<br>Standby current level after nonvolatile cycle is complete.<br>Inputs are static. $f = 0$ MHz.                 |                |                     | 5              | mA      |
| $I_{IX}$ <sup>[15]</sup>  | Input Leakage Current (except HSB)                                  | $V_{CC} = \text{Max}$ , $V_{SS} \leq V_{IN} \leq V_{CC}$  | -1             |                     | +1             | $\mu A$ |
|                           | Input Leakage Current (for HSB)                                     | $V_{CC} = \text{Max}$ , $V_{SS} \leq V_{IN} \leq V_{CC}$  | -100           |                     | +1             | $\mu A$ |
| $I_{OZ}$                  | Off State Output Leakage Current                                    | $V_{CC} = \text{Max}$ , $V_{SS} \leq V_{OUT} \leq V_{CC}$ , $\overline{CE}$ or $\overline{OE} \geq V_{IH}$ or $\overline{BHE}/\overline{BLE} \geq V_{IH}$<br>or $\overline{WE} \leq V_{IL}$ | -1             |                     | +1             | $\mu A$ |
| $V_{IH}$                  | Input HIGH Voltage  |   | 2.0            |                     | $V_{CC} + 0.5$ | V       |
| $V_{IL}$                  | Input LOW Voltage   |   | $V_{SS} - 0.5$ |                     | 0.8            | V       |
| $V_{OH}$                  | Output HIGH Voltage   | $I_{OUT} = -2$ mA   | 2.4            |                     |                | V       |
| $V_{OL}$                  | Output LOW Voltage  | $I_{OUT} = 4$ mA  |                |                     | 0.4            | V       |
| $V_{CAP}$                 | Storage Capacitor   | Between $V_{CAP}$ pin and $V_{SS}$ , 5V Rated   | 61             | 68                  | 180            | $\mu F$ |

### Notes

14. Typical values are at 25°C,  $V_{CC} = V_{CC}$  (Typ). Not 100% tested.

15. The HSB pin has  $I_{OUT} = -2$   $\mu A$  for  $V_{OH}$  of 2.4V when both active HIGH and low drivers are disabled. When they are enabled standard  $V_{OH}$  and  $V_{OL}$  are valid. This parameter is characterized but not tested.

Package Power Dissipation

Capability ( $T_A = 25^\circ C$ ) ..... 1.0W

Surface Mount Pb Soldering

Temperature (3 Seconds)..... +260°C

DC Output Current (1 output at a time, 1s duration)..... 15 mA

Static Discharge Voltage..... > 2001V  
(per MIL-STD-883, Method 3015)

Latch Up Current ..... > 200 mA

## Operating Range

| Range      | Ambient Temperature | $V_{CC}$     |
|------------|---------------------|--------------|
| Commercial | 0°C to +70°C        | 2.7V to 3.6V |
| Industrial | -40°C to +85°C      |              |

## Capacitance

| Parameter <sup>[16]</sup> | Description        | Test Conditions  | Max | Unit |
|---------------------------|--------------------|--|-----|------|
| C <sub>IN</sub>           | Input Capacitance  | T <sub>A</sub> = 25°C, f = 1 MHz,<br>V <sub>CC</sub> = V <sub>CC</sub> (Typ) | 7   | pF   |
| C <sub>OUT</sub>          | Output Capacitance |  | 7   | pF   |

## Thermal Resistance

| Parameter <sup>[16]</sup> | Description                              | Test Conditions   | 48 SSOP | 44 TSOP II | 54 TSOP II | Unit |
|---------------------------|--|---|---------|------------|------------|------|
| Θ <sub>JA</sub>           | Thermal Resistance (Junction to Ambient) | Test conditions follow standard test methods and procedures for measuring thermal impedance, in accordance with EIA/JESD51. | TBD     | 31.11      | 30.73      | °C/W |
| Θ <sub>JC</sub>           | Thermal Resistance (Junction to Case)    |   | TBD     | 5.56       | 6.08       | °C/W |

Figure 6. AC Test Loads

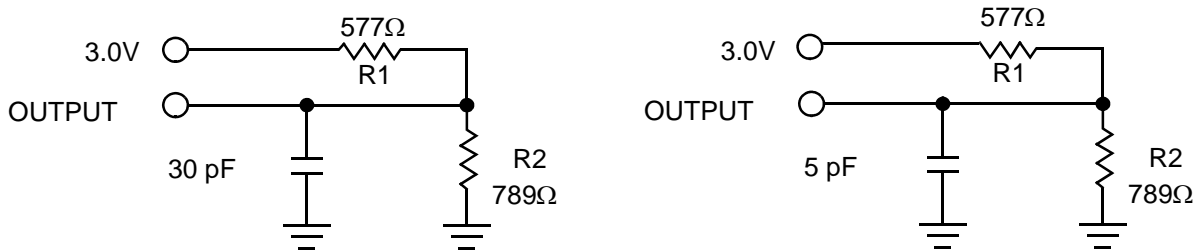

## AC Test Conditions

Input Pulse Levels .....0V to 3V  
 Input Rise and Fall Times (10% - 90%) ..... ≤3 ns  
 Input and Output Timing Reference Levels ..... 1.5V

## RTC Characteristics

| Parameters                          | Description   |                      | Min | Typ <sup>[14]</sup> | Max | Units |
|-------------------------------------|---|----------------------|-----|---------------------|-----|-------|
| V <sub>RTCbat</sub>                 | RTC Battery Pin Voltage                               |                      | 1.8 | 3.0                 | 3.3 | V     |
| I <sub>BAK</sub> <sup>[17]</sup>    | RTC Backup Current                                    | T <sub>A</sub> (Min) |     |                     | 350 | nA    |
|                                     |   | 25°C                 |     | 350                 |     | nA    |
|                                     |   | T <sub>A</sub> (Max) |     |                     | 500 | nA    |
| V <sub>RTCcap</sub> <sup>[18]</sup> | RTC Capacitor Pin Voltage                             | T <sub>A</sub> (Min) | 1.6 | 3.0                 | 3.6 | V     |
|                                     |   | 25°C                 | 1.5 | 3.0                 | 3.6 | V     |
|                                     |   | T <sub>A</sub> (Max) | 1.4 | 3.0                 | 3.6 | V     |
| t <sub>OCS</sub>                    | RTC Oscillator Time to Start                          |                      |     | 1                   | 2   | sec   |
| R <sub>BKCHG</sub>                  | RTC Backup Capacitor Charge Current-Limiting Resistor |                      | 450 |                     | 850 | Ω     |

### Notes

16. These parameters are guaranteed by design and are not tested.

17. From either V<sub>RTCcap</sub> or V<sub>RTCbat</sub>.

18. If V<sub>RTCcap</sub> > 0.3V or if no capacitor is connected to V<sub>RTCcap</sub> pin, the oscillator starts in t<sub>OCS</sub> time. If a backup capacitor is connected and vrtc cap < 0.3V, the capacitor must be allowed to charge to 0.3V for oscillator to start.



## AC Switching Characteristics

| Parameters                |                | Description                       | 20 ns |     | 25 ns |     | 45 ns |     | Unit |
|---------------------------|----------------|-----------------------------------|-------|-----|-------|-----|-------|-----|------|
| Cypress Parameters        | Alt Parameters |                                   | Min   | Max | Min   | Max | Min   | Max |      |
| <b>SRAM Read Cycle</b>    |                |                                   |       |     |       |     |       |     |      |
| $t_{ACE}$                 | $t_{ACS}$      | Chip Enable Access Time           |       | 20  |       | 25  |       | 45  | ns   |
| $t_{RC}^{[19]}$           | $t_{RC}$       | Read Cycle Time                   | 20    |     | 25    |     | 45    |     | ns   |
| $t_{AA}^{[20]}$           | $t_{AA}$       | Address Access Time               |       | 20  |       | 25  |       | 45  | ns   |
| $t_{DOE}$                 | $t_{OE}$       | Output Enable to Data Valid       |       | 10  |       | 12  |       | 20  | ns   |
| $t_{OHA}^{[20]}$          | $t_{OH}$       | Output Hold After Address Change  | 3     |     | 3     |     | 3     |     | ns   |
| $t_{LZCE}^{[16, 21]}$     | $t_{LZ}$       | Chip Enable to Output Active      | 3     |     | 3     |     | 3     |     | ns   |
| $t_{HZCE}^{[16, 21]}$     | $t_{HZ}$       | Chip Disable to Output Inactive   |       | 8   |       | 10  |       | 15  | ns   |
| $t_{LZOE}^{[16, 21]}$     | $t_{OLZ}$      | Output Enable to Output Active    | 0     |     | 0     |     | 0     |     | ns   |
| $t_{HZOE}^{[16, 21]}$     | $t_{OHZ}$      | Output Disable to Output Inactive |       | 8   |       | 10  |       | 15  | ns   |
| $t_{PU}^{[16]}$           | $t_{PA}$       | Chip Enable to Power Active       | 0     |     | 0     |     | 0     |     | ns   |
| $t_{PD}^{[16]}$           | $t_{PS}$       | Chip Disable to Power Standby     |       | 20  |       | 25  |       | 45  | ns   |
| $t_{DBE}$                 | -              | Byte Enable to Data Valid         |       | 10  |       | 12  |       | 20  | ns   |
| $t_{LZBE}^{[16]}$         | -              | Byte Enable to Output Active      | 0     |     | 0     |     | 0     |     | ns   |
| $t_{HZBE}^{[16]}$         | -              | Byte Disable to Output Inactive   |       | 8   |       | 10  |       | 15  | ns   |
| <b>SRAM Write Cycle</b>   |                |                                   |       |     |       |     |       |     |      |
| $t_{WC}$                  | $t_{WC}$       | Write Cycle Time                  | 20    |     | 25    |     | 45    |     | ns   |
| $t_{PWE}$                 | $t_{WP}$       | Write Pulse Width                 | 15    |     | 20    |     | 30    |     | ns   |
| $t_{SCE}$                 | $t_{CW}$       | Chip Enable To End of Write       | 15    |     | 20    |     | 30    |     | ns   |
| $t_{SD}$                  | $t_{DW}$       | Data Setup to End of Write        | 8     |     | 10    |     | 15    |     | ns   |
| $t_{HD}$                  | $t_{DH}$       | Data Hold After End of Write      | 0     |     | 0     |     | 0     |     | ns   |
| $t_{AW}$                  | $t_{AW}$       | Address Setup to End of Write     | 15    |     | 20    |     | 30    |     | ns   |
| $t_{SA}$                  | $t_{AS}$       | Address Setup to Start of Write   | 0     |     | 0     |     | 0     |     | ns   |
| $t_{HA}$                  | $t_{WR}$       | Address Hold After End of Write   | 0     |     | 0     |     | 0     |     | ns   |
| $t_{HZWE}^{[16, 21, 22]}$ | $t_{WZ}$       | Write Enable to Output Disable    |       | 8   |       | 10  |       | 15  | ns   |
| $t_{LZWE}^{[16, 21]}$     | $t_{OW}$       | Output Active after End of Write  | 3     |     | 3     |     | 3     |     | ns   |
| $t_{BW}$                  | -              | Byte Enable to End of Write       | 15    |     | 20    |     | 30    |     | ns   |

## Switching Waveforms

Figure 7. SRAM Read Cycle #1: Address Controlled [19, 20, 23]

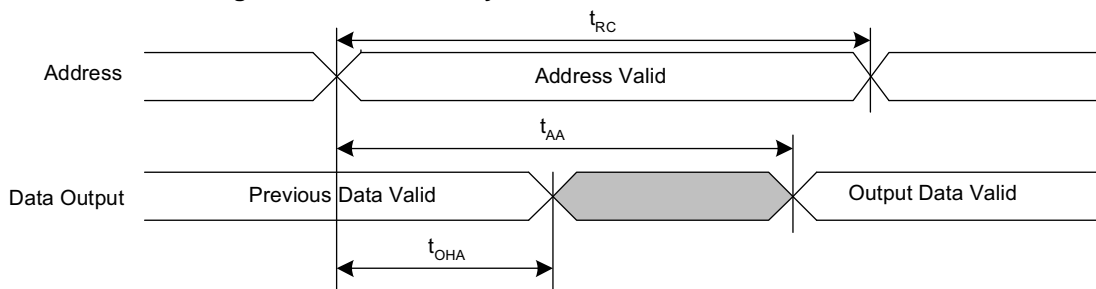

### Notes

19. WE must be HIGH during SRAM read cycles.
20. Device is continuously selected with CE, OE and BHE/BLE LOW.
21. Measured  $\pm 200$  mV from steady state output voltage.
22. If WE is low when CE goes low, the outputs remain in the high impedance state.
23. HSB must remain HIGH during Read and Write cycles.

Figure 8. SRAM Read Cycle #2:  $\overline{\text{CE}}$  Controlled [3, 19, 23]

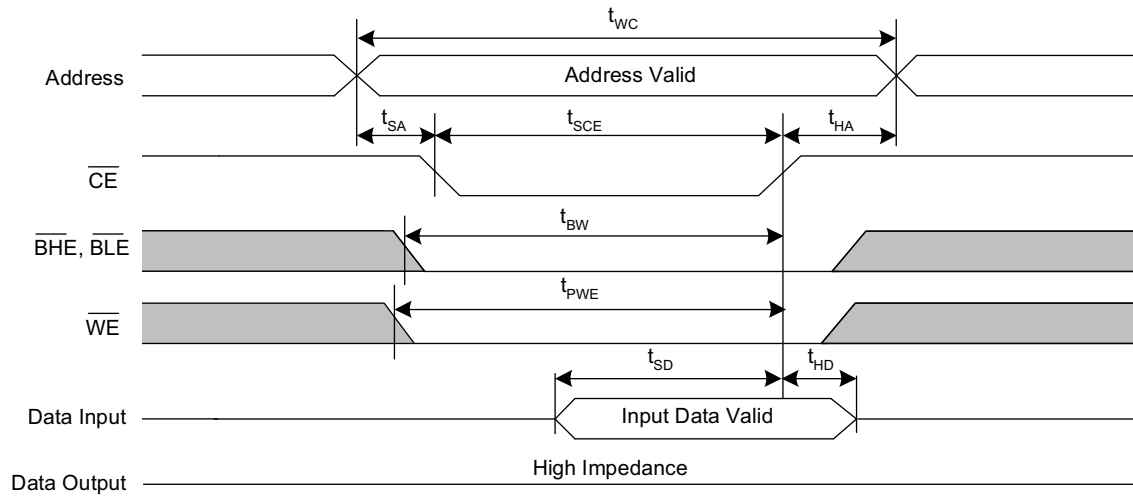
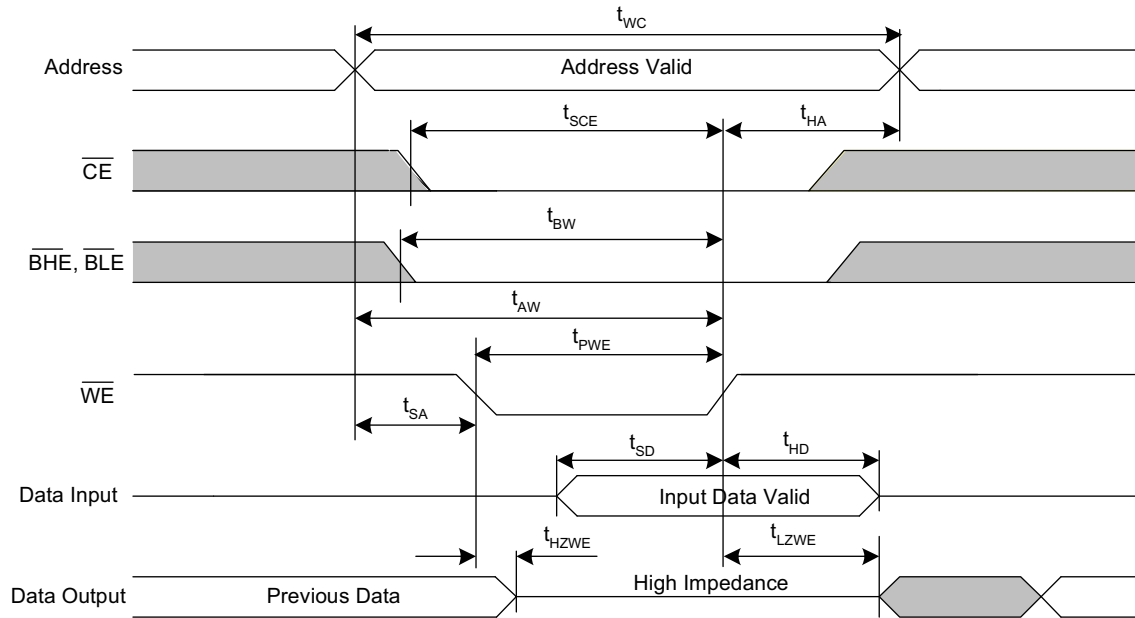

Figure 9. SRAM Write Cycle #1:  $\overline{\text{WE}}$  Controlled [3, 22, 23, 24]



**Note**

24.  $\overline{\text{CE}}$  or  $\overline{\text{WE}}$  must be  $\geq V_{IH}$  during address transitions.

Figure 10. SRAM Write Cycle #2:  $\overline{\text{CE}}$  Controlled [3, 22, 23, 24]

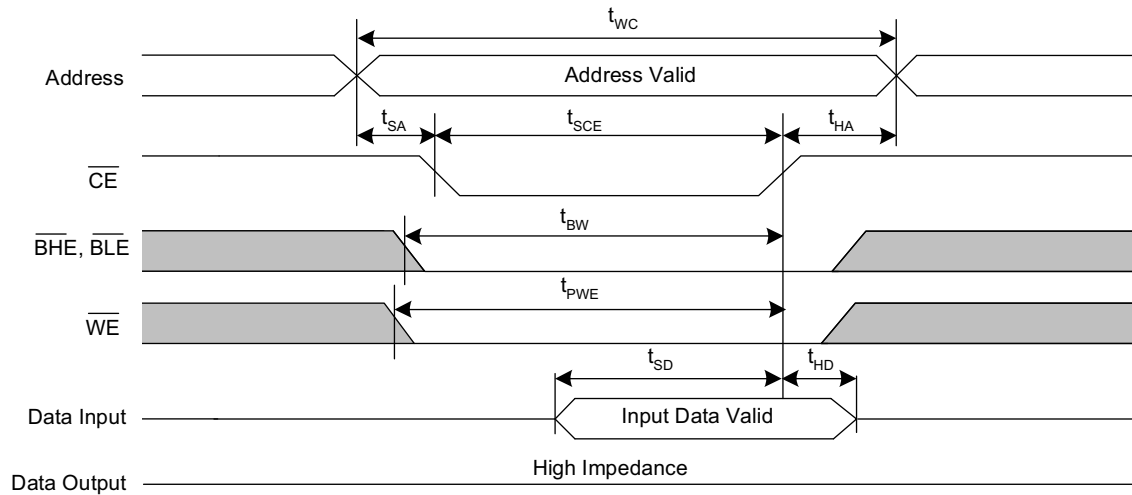
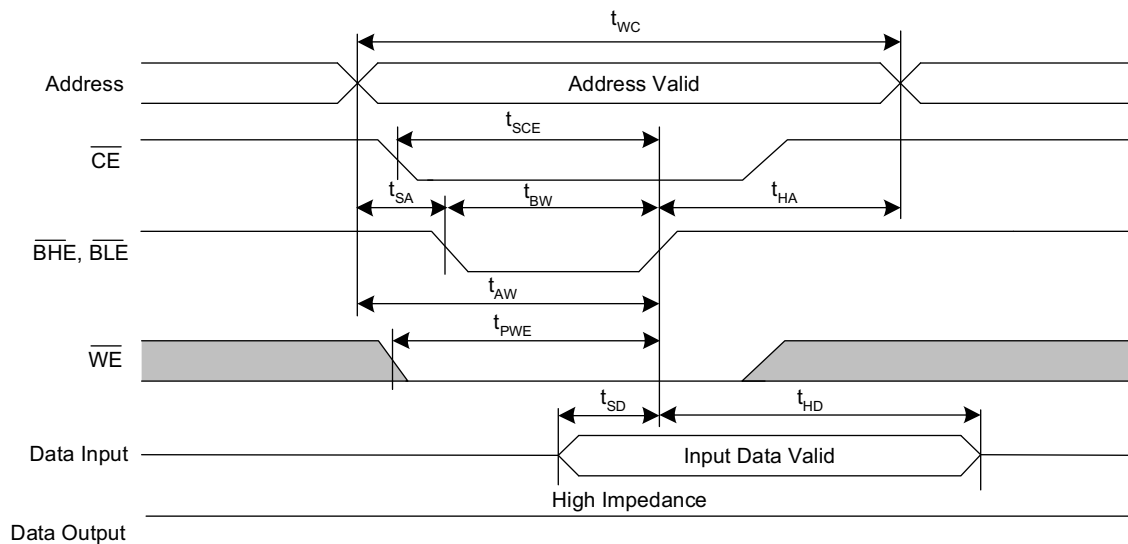

Figure 11. SRAM Write Cycle #3:  $\overline{\text{BHE}}$  and  $\overline{\text{BLE}}$  Controlled [3, 22, 23, 24, 25]  
(Not applicable for RTC register writes)



**Note**

25. Only  $\overline{\text{CE}}$  and  $\overline{\text{WE}}$  controlled writes to RTC registers are allowed.  $\overline{\text{BLE}}$  pin must be held LOW before  $\overline{\text{CE}}$  or  $\overline{\text{WE}}$  pin goes LOW for writes to RTC register.

## AutoStore/Power Up RECALL

| Parameters            | Description                               | 20ns |      | 25ns |      | 45ns |      | Unit    |
|-----------------------|---|------|------|------|------|------|------|---------|
|                       |   | Min  | Max  | Min  | Max  | Min  | Max  |         |
| $t_{HRECALL}^{[26]}$  | Power Up RECALL Duration                  |      | 20   |      | 20   |      | 20   | ms      |
| $t_{STORE}^{[27]}$    | STORE Cycle Duration                      |      | 8    |      | 8    |      | 8    | ms      |
| $t_{DELAY}^{[28]}$    | Time Allowed to Complete SRAM Write Cycle |      | 20   |      | 25   |      | 25   | ns      |
| $V_{SWITCH}$          | Low Voltage Trigger Level                 |      | 2.65 |      | 2.65 |      | 2.65 | V       |
| $t_{VCCRRISE}^{[16]}$ | VCC Rise Time                             | 150  |      | 150  |      | 150  |      | $\mu$ s |
| $V_{HDIS}^{[16]}$     | HSB Output Disable Voltage                |      | 1.9  |      | 1.9  |      | 1.9  | V       |
| $t_{LZHSB}^{[16]}$    | HSB To Output Active Time                 |      | 5    |      | 5    |      | 5    | $\mu$ s |
| $t_{HHHD}^{[16]}$     | HSB High Active Time                      |      | 500  |      | 500  |      | 500  | ns      |

## Switching Waveforms

Figure 12. AutoStore or Power Up RECALL <sup>[29]</sup>

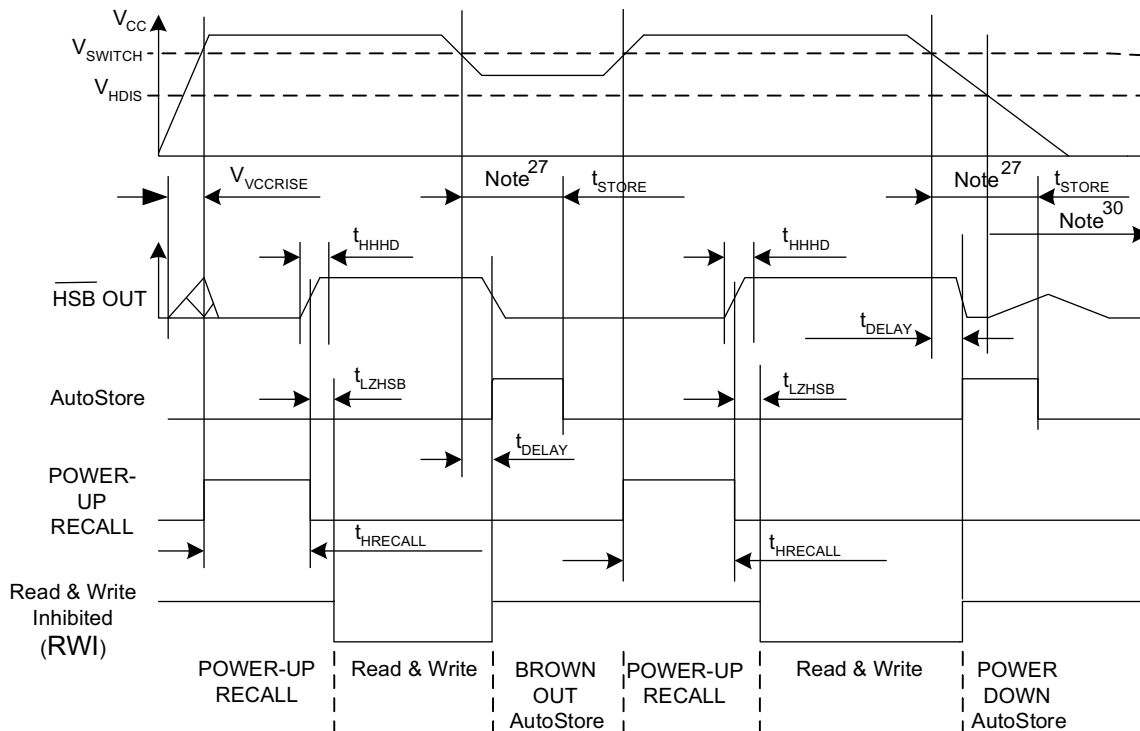

### Notes

26.  $t_{HRECALL}$  starts from the time  $V_{CC}$  rises above  $V_{SWITCH}$ .

27. If an SRAM write has not taken place since the last nonvolatile cycle, no AutoStore or Hardware STORE takes place.

28. On a Hardware Store and AutoStore initiation, SRAM write operation continues to be enabled for time  $t_{DELAY}$ .

29. Read and Write cycles are ignored during STORE, RECALL, and while  $V_{CC}$  is below  $V_{SWITCH}$ .

30. HSB pin is driven HIGH to VCC only by internal 100 k $\Omega$  resistor, HSB driver is disabled.

## Software Controlled STORE/RECALL Cycle

| Parameters <sup>[31, 32]</sup> | Description                        | 20 ns |     | 25 ns |     | 45 ns |     | Unit    |
|--------------------------------|------------------------------------|-------|-----|-------|-----|-------|-----|---------|
|                                |                                    | Min   | Max | Min   | Max | Min   | Max |         |
| $t_{RC}$                       | STORE/RECALL Initiation Cycle Time | 20    |     | 25    |     | 45    |     | ns      |
| $t_{SA}$                       | Address Setup Time                 | 0     |     | 0     |     | 0     |     | ns      |
| $t_{CW}$                       | Clock Pulse Width                  | 15    |     | 20    |     | 30    |     | ns      |
| $t_{HA}$                       | Address Hold Time                  | 0     |     | 0     |     | 0     |     | ns      |
| $t_{RECALL}$                   | RECALL Duration                    |       | 200 |       | 200 |       | 200 | $\mu$ s |
| $t_{SS}$ <sup>[33, 34]</sup>   | Soft Sequence Processing Time      |       | 100 |       | 100 |       | 100 | $\mu$ s |

## Switching Waveforms

Figure 13.  $\overline{CE}$  &  $\overline{OE}$  Controlled Software STORE/RECALL Cycle <sup>[32]</sup>

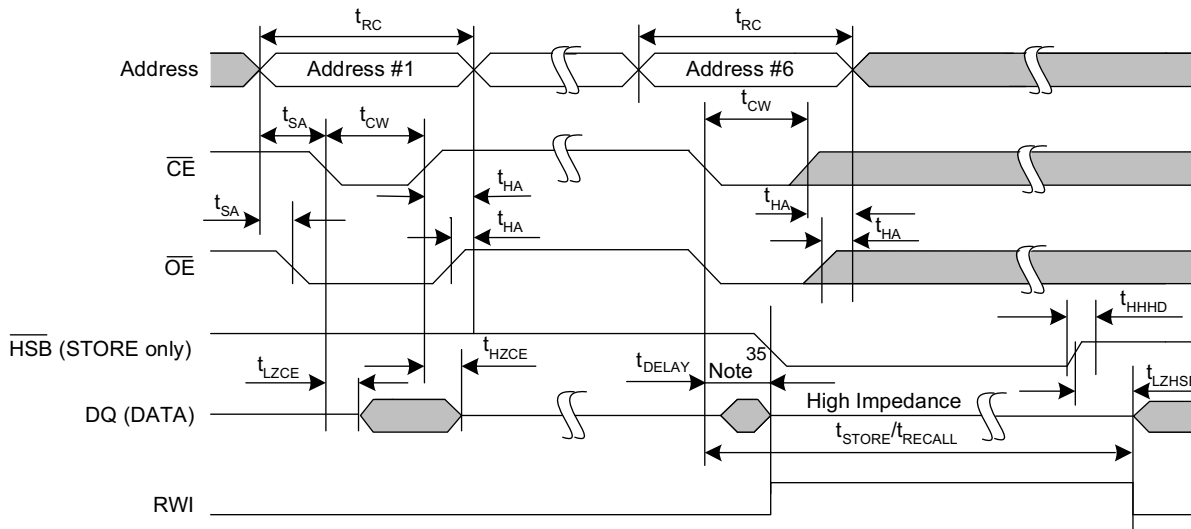
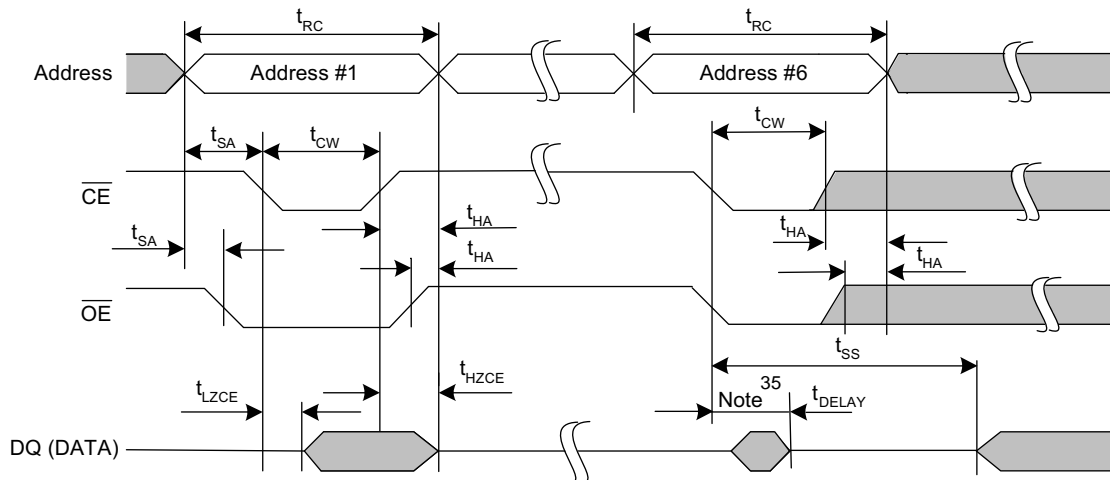

Figure 14. AutoStore Enable/Disable Cycle



### Notes

31. The software sequence is clocked with  $\overline{CE}$  controlled or  $\overline{OE}$  controlled reads.
32. The six consecutive addresses must be read in the order listed in Table 1. WE must be HIGH during all six consecutive cycles.
33. This is the amount of time it takes to take action on a soft sequence command. Vcc power must remain HIGH to effectively register command.
34. Commands such as STORE and RECALL lock out I/O until operation is complete which further increases this time. See the specific command.
35. DQ output data at the sixth read may be invalid since the output is disabled at  $t_{DELAY}$  time.

### Hardware STORE Cycle

| Parameters | Description  | 20ns |     | 25ns |     | 45ns |     | Unit |
|------------|--|------|-----|------|-----|------|-----|------|
|            |  | Min  | Max | Min  | Max | Min  | Max |      |
| $t_{DHSB}$ | HSB To Output Active Time when write latch not set |      | 20  |      | 25  |      | 25  | ns   |
| $t_{PHSB}$ | Hardware STORE Pulse Width                         | 15   |     | 15   |     | 15   |     | ns   |

### Switching Waveforms

Figure 15. Hardware STORE Cycle<sup>[27]</sup>

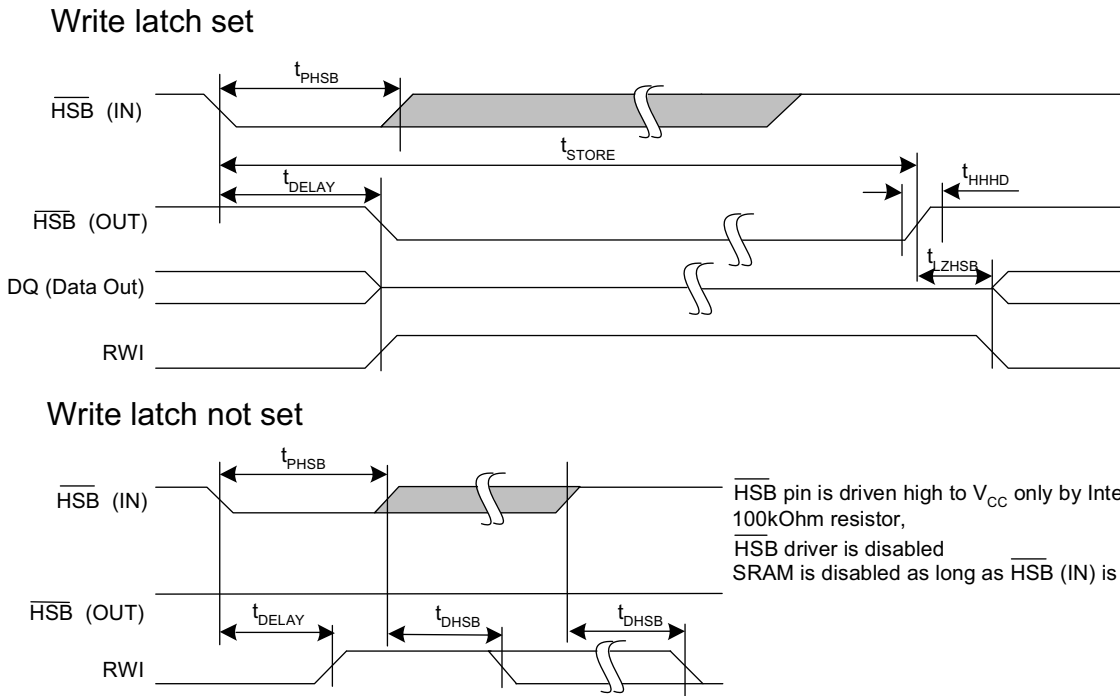
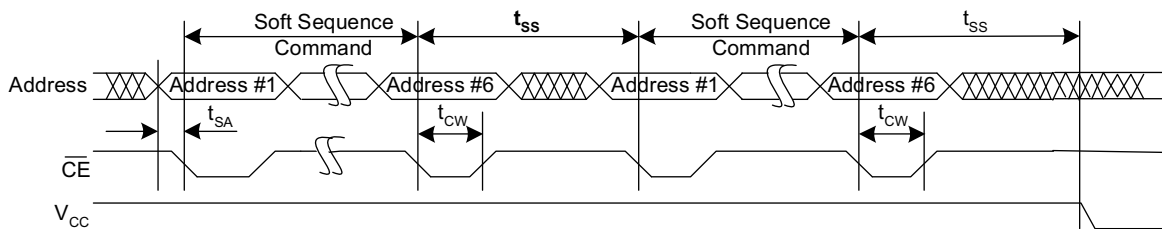

Figure 16. Soft Sequence Processing<sup>[33, 34]</sup>



## Truth Table For SRAM Operations

$\overline{\text{HSB}}$  must remain HIGH for SRAM operations.

Table 5. Truth Table for x8 Configuration

| $\overline{\text{CE}}$ | $\overline{\text{WE}}$ | $\overline{\text{OE}}$ | Inputs/Outputs <sup>[2]</sup>                | Mode                | Power   |
|------------------------|------------------------|------------------------|--|---------------------|---------|
| H                      | X                      | X                      | High Z                                       | Deselect/Power down | Standby |
| L                      | H                      | L                      | Data Out (DQ <sub>0</sub> –DQ <sub>7</sub> ) | Read                | Active  |
| L                      | H                      | H                      | High Z                                       | Output Disabled     | Active  |
| L                      | L                      | X                      | Data in (DQ <sub>0</sub> –DQ <sub>7</sub> )  | Write               | Active  |

Table 6. Truth Table for x16 Configuration

| $\overline{\text{CE}}$ | $\overline{\text{WE}}$ | $\overline{\text{OE}}$ | $\overline{\text{BHE}}$ <sup>[3]</sup> | $\overline{\text{BLE}}$ <sup>[3]</sup> | Inputs/Outputs <sup>[2]</sup>   | Mode                | Power   |
|------------------------|------------------------|------------------------|--|--|---|---------------------|---------|
| H                      | X                      | X                      | X                                      | X                                      | High-Z  | Deselect/Power down | Standby |
| L                      | X                      | X                      | H                                      | H                                      | High-Z  | Output Disabled     | Active  |
| L                      | H                      | L                      | L                                      | L                                      | Data Out (DQ <sub>0</sub> –DQ <sub>15</sub> )   | Read                | Active  |
| L                      | H                      | L                      | H                                      | L                                      | Data Out (DQ <sub>0</sub> –DQ <sub>7</sub> )<br>DQ <sub>8</sub> –DQ <sub>15</sub> in High-Z | Read                | Active  |
| L                      | H                      | L                      | L                                      | H                                      | Data Out (DQ <sub>8</sub> –DQ <sub>15</sub> )<br>DQ <sub>0</sub> –DQ <sub>7</sub> in High-Z | Read                | Active  |
| L                      | H                      | H                      | L                                      | L                                      | High-Z  | Output Disabled     | Active  |
| L                      | H                      | H                      | H                                      | L                                      | High-Z  | Output Disabled     | Active  |
| L                      | H                      | H                      | L                                      | H                                      | High-Z  | Output Disabled     | Active  |
| L                      | L                      | X                      | L                                      | L                                      | Data In (DQ <sub>0</sub> –DQ <sub>15</sub> )  | Write               | Active  |
| L                      | L                      | X                      | H                                      | L                                      | Data In (DQ <sub>0</sub> –DQ <sub>7</sub> )<br>DQ <sub>8</sub> –DQ <sub>15</sub> in High-Z  | Write               | Active  |
| L                      | L                      | X                      | L                                      | H                                      | Data In (DQ <sub>8</sub> –DQ <sub>15</sub> )<br>DQ <sub>0</sub> –DQ <sub>7</sub> in High-Z  | Write               | Active  |

## Part Numbering Nomenclature

### CY 14 B 101 K A -ZS P 20 X C T

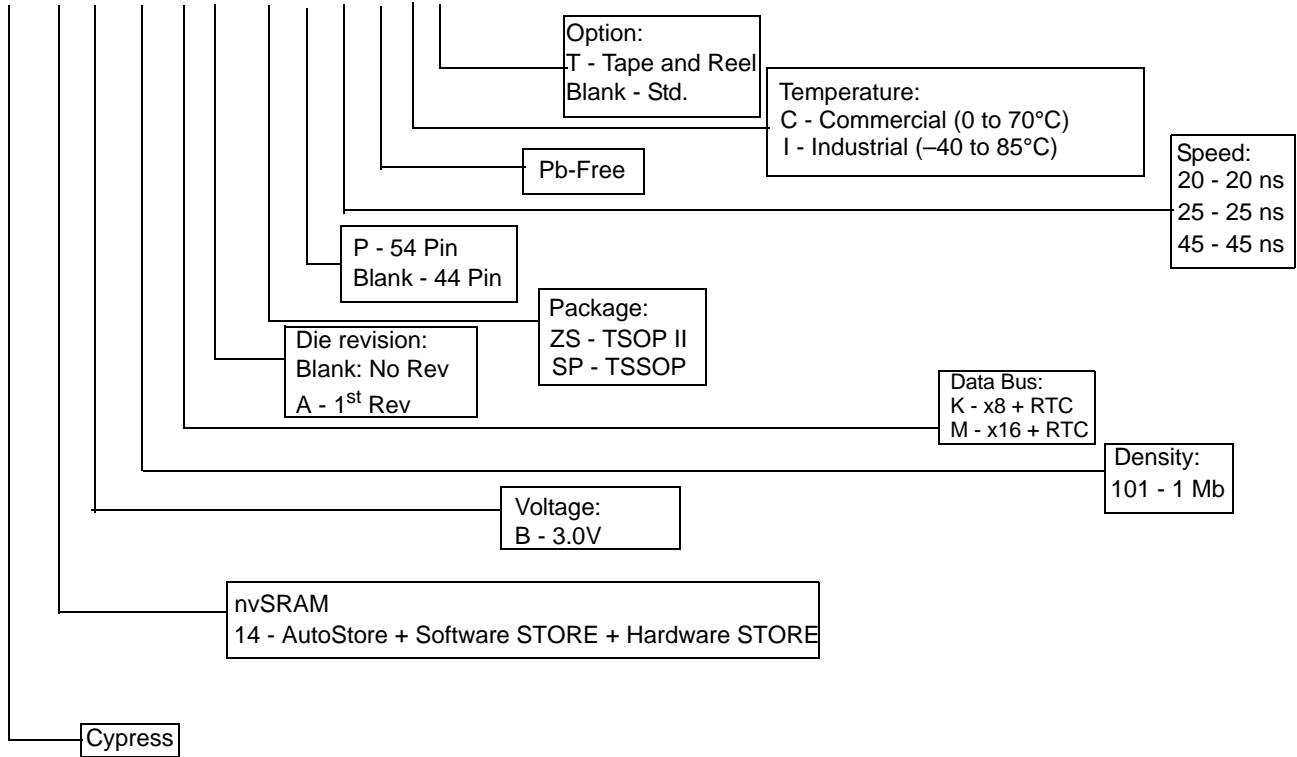



## Ordering Information

| Speed (ns) | Ordering Code       | Package Diagram     | Package Type  | Operating Range |            |
|------------|---------------------|---------------------|---------------|-----------------|------------|
| 20         | CY14B101KA-ZS20XCT  | 51-85087            | 44-pin TSOPII | Commercial      |            |
|            | CY14B101KA-ZS20XC   | 51-85087            | 44-pin TSOPII |                 |            |
|            | CY14B101MA-ZSP20XCT | 51-85160            | 54-pin TSOPII |                 |            |
|            | CY14B101MA-ZSP20XC  | 51-85160            | 54-pin TSOPII |                 |            |
|            | CY14B101KA-SP20XCT  | 51-85061            | 48-pin SSOP   |                 |            |
|            | CY14B101KA-SP20XC   | 51-85061            | 48-pin SSOP   |                 |            |
|            | 20                  | CY14B101KA-ZS20XIT  | 51-85087      | 44-pin TSOPII   | Industrial |
|            |                     | CY14B101KA-ZS20XI   | 51-85087      | 44-pin TSOPII   |            |
|            |                     | CY14B101MA-ZSP20XIT | 51-85160      | 54-pin TSOPII   |            |
|            |                     | CY14B101MA-ZSP20XI  | 51-85160      | 54-pin TSOPII   |            |
|            |                     | CY14B101KA-SP20XIT  | 51-85061      | 48-pin SSOP     |            |
|            |                     | CY14B101KA-SP20XI   | 51-85061      | 48-pin SSOP     |            |
| 25         | CY14B101KA-ZS25XCT  | 51-85087            | 44-pin TSOPII | Commercial      |            |
|            | CY14B101KA-ZS25XC   | 51-85087            | 44-pin TSOPII |                 |            |
|            | CY14B101MA-ZSP25XCT | 51-85160            | 54-pin TSOPII |                 |            |
|            | CY14B101MA-ZSP25XC  | 51-85160            | 54-pin TSOPII |                 |            |
|            | CY14B101KA-SP25XCT  | 51-85061            | 48-pin SSOP   |                 |            |
|            | CY14B101KA-SP25XC   | 51-85061            | 48-pin SSOP   |                 |            |
|            | 25                  | CY14B101KA-ZS25XIT  | 51-85087      | 44-pin TSOPII   | Industrial |
|            |                     | CY14B101KA-ZS25XI   | 51-85087      | 44-pin TSOPII   |            |
|            |                     | CY14B101MA-ZSP25XIT | 51-85160      | 54-pin TSOPII   |            |
|            |                     | CY14B101MA-ZSP25XI  | 51-85160      | 54-pin TSOPII   |            |
|            |                     | CY14B101KA-SP25XIT  | 51-85061      | 48-pin SSOP     |            |
|            |                     | CY14B101KA-SP25XI   | 51-85061      | 48-pin SSOP     |            |
| 45         | CY14B101KA-ZS45XCT  | 51-85087            | 44-pin TSOPII | Commercial      |            |
|            | CY14B101KA-ZS45XC   | 51-85087            | 44-pin TSOPII |                 |            |
|            | CY14B101MA-ZSP45XCT | 51-85160            | 54-pin TSOPII |                 |            |
|            | CY14B101MA-ZSP45XC  | 51-85160            | 54-pin TSOPII |                 |            |
|            | CY14B101KA-SP45XCT  | 51-85061            | 48-pin SSOP   |                 |            |
|            | CY14B101KA-SP45XC   | 51-85061            | 48-pin SSOP   |                 |            |
|            | 45                  | CY14B101KA-ZS45XIT  | 51-85087      | 44-pin TSOPII   | Industrial |
|            |                     | CY14B101KA-ZS45XI   | 51-85087      | 44-pin TSOPII   |            |
|            |                     | CY14B101MA-ZSP45XIT | 51-85160      | 54-pin TSOPII   |            |
|            |                     | CY14B101MA-ZSP45XI  | 51-85160      | 54-pin TSOPII   |            |
|            |                     | CY14B101KA-SP45XIT  | 51-85061      | 48-pin SSOP     |            |
|            |                     | CY14B101KA-SP45XI   | 51-85061      | 48-pin SSOP     |            |

All parts are Pb-free. This table contains Preliminary information. Contact your local Cypress sales representative for availability of these parts.

Package Diagrams

Figure 17. 44-Pin TSOP II (51-85087)

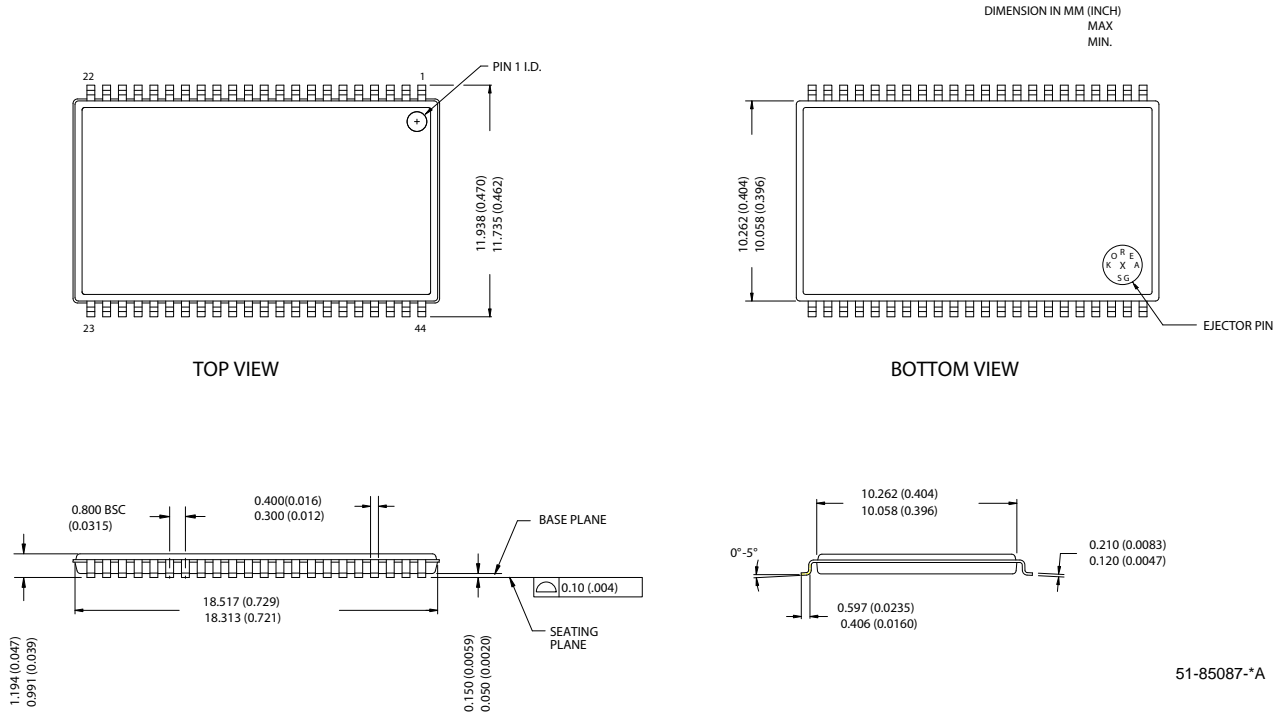
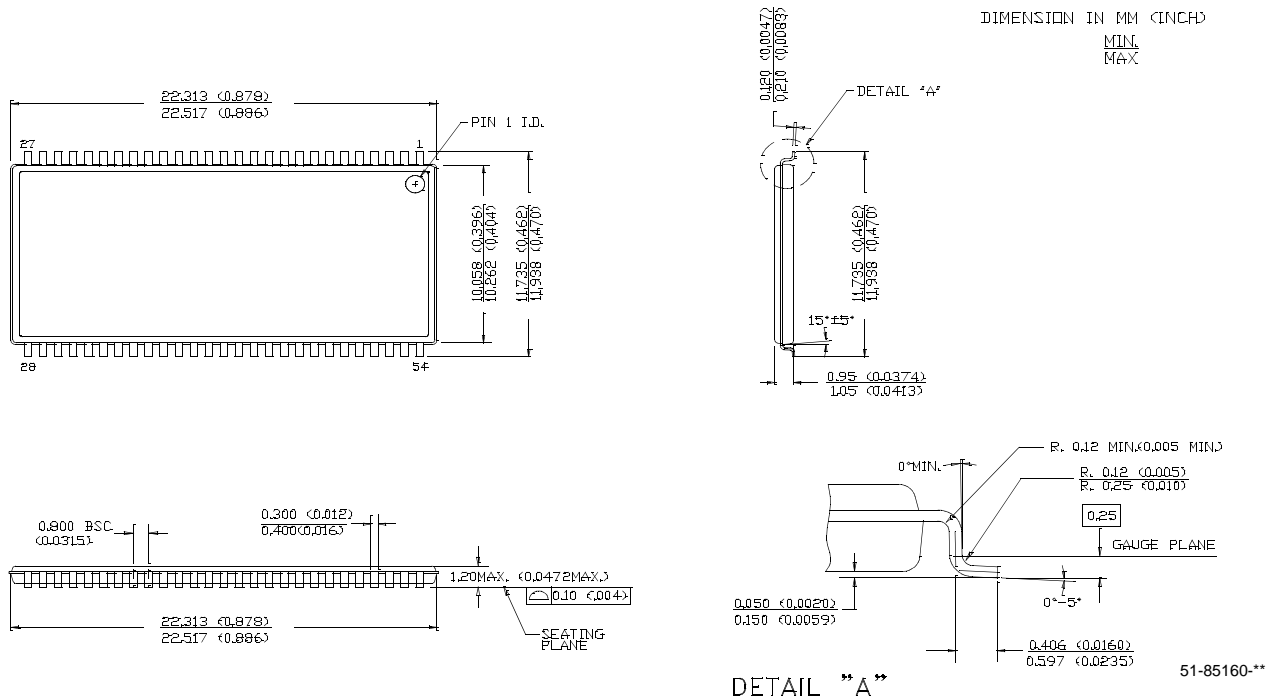
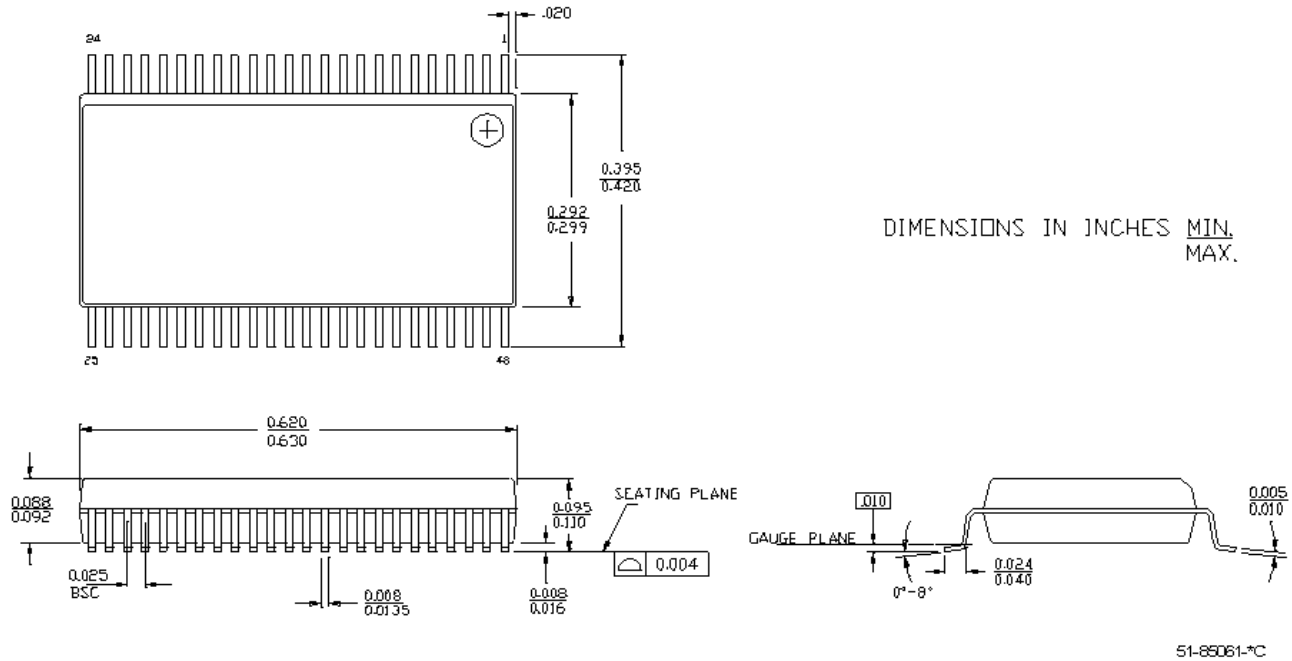

Figure 18. 54-Pin TSOP II (51-85160)



Package Diagrams (continued)

Figure 19. 48-Pin SSOP (51-85061)



**Document History Page**

| Document Title: CY14B101KA/CY14B101MA 1 Mbit (128K x 8/64K x 16) nvSRAM with Real Time Clock |         |                 |                 |   |
|--|---------|-----------------|-----------------|---|
| Document Number: 001-42880   |         |                 |                 |   |
| Rev.   | ECN No. | Submission Date | Orig. of Change | Description of Change   |
| **   | 2050747 | See ECN         | UNC/PYRS        | New Data Sheet  |
| *A   | 2607447 | 11/18/2008      | GVCH/AESA       | <p>Removed 15 ns access speed, updated "Features", added CY14B101MA (x16) part, changed title to "CY14B101KA/CY14B101MA 1 Mbit (128K x 8/64K x 16) nvSRAM with Real-Time-Clock".</p> <p>Added 54-pin TSOP II package related information, updated Logic block diagram, added footnote 1 and 2.</p> <p>Pin definition: Updated WE, HSB and NC pin description.</p> <p>Page 4: Updated SRAM READ, SRAM WRITE, Autostore operation description,</p> <p>Page 4: Updated Software store and software recall description</p> <p>Updated Figure 2, Page 4: Updated Hardware store operation and Hardware RECALL (Power up) description</p> <p>Footnote 1 and 10 referenced for Mode selection Table</p> <p>Added footnote 10, updated footnote 8 and 9</p> <p>Page 6: updated Data protection description</p> <p>Page 6: Updated starting and stopping the oscillator description</p> <p>Page 7: Updated Calibrating the clock description</p> <p>Page 8: Added Flags register</p> <p>Updated table 4, added footnote 12 and 13</p> <p>Updated Register map detail Table 5</p> <p>Maximum Ratings: Added Max. Accumulated storage time</p> <p>Changed Output short circuit current parameter name to DC output current</p> <p>Changed I<sub>CC2</sub> from 6 mA to 10 mA</p> <p>Changed I<sub>CC3</sub> from 15 mA to 35 mA</p> <p>Changed I<sub>CC4</sub> from 6 mA to 5 mA</p> <p>Changed I<sub>SB</sub> from 3 mA to 5 mA</p> <p>Added I<sub>IX</sub> for HSB</p> <p>Updated I<sub>CC1</sub>, I<sub>CC3</sub>, I<sub>SB</sub> and I<sub>OZ</sub> Test conditions</p> <p>Changed V<sub>CAP</sub> voltage min value from 68uF to 61uF</p> <p>Added V<sub>CAP</sub> voltage max value to 180uF</p> <p>Updated footnote 14 and 15, added footnote 16</p> <p>Added Data retention and Endurance Table</p> <p>Added thermal resistance value to 44/54 TSOP II packages</p> <p>Updated Input Rise and Fall time in AC test Conditions</p> <p>Changed V<sub>RTCcap min</sub> value from 1.2 to 1.5V for industrial Commercial temperature</p> <p>Changed V<sub>RTCcap min</sub> value from 2.7 to 3.6V for industrial Commercial temperature</p> <p>Updated RTC recommended component configuration values</p> <p>Updated t<sub>OCS</sub> value for minimum and room temperature from 10 and 5sec to 2 and 1sec resp.</p> <p>Referenced footnote 22 to t<sub>OHA</sub> parameter</p> <p>Updated All switching waveforms</p> <p>Updated footnote 22, added footnote 25</p> <p>Added Figure 11 (SRAM WRITE CYCLE:BHE and BLE controlled)</p> <p>Changed t<sub>STORE</sub> max value from 15ms to 8ms</p> <p>Updated t<sub>DELAY</sub> value</p> <p>Added V<sub>HDIS</sub>, t<sub>HHD</sub> and t<sub>LZHSB</sub> parameters</p> <p>Updated footnote 29, added footnote 31 and 32</p> <p>Software controlled STORE/RECALL Table: Changed t<sub>AS</sub> to t<sub>SA</sub></p> <p>Changed t<sub>GHAX</sub> to t<sub>HA</sub>, changed t<sub>HA</sub> value from 1ns to 0ns</p> <p>Added Figure 14</p> <p>Added t<sub>DHSB</sub> parameter, changed t<sub>HLHX</sub> to t<sub>PHSB</sub></p> <p>Updated t<sub>SS</sub> from 70 us to 100 us, added truth table for SRAM operations</p> <p>Updated ordering information and part numbering nomenclature</p> |

| Document Title: CY14B101KA/CY14B101MA 1 Mbit (128K x 8/64K x 16) nvSRAM with Real Time Clock |         |                 |                 |  |
|--|---------|-----------------|-----------------|--|
| Document Number: 001-42880   |         |                 |                 |  |
| Rev.   | ECN No. | Submission Date | Orig. of Change | Description of Change  |
| *B   | 2654484 | 02/05/09        | GVCH/PYRS       | Changed the data sheet from Advance information to Preliminary<br>Changed X <sub>1</sub> , X <sub>2</sub> pin names to X <sub>out</sub> , X <sub>in</sub> respectively<br>Updated Real Time Clock operation description<br>Added footnotes 11 and 12<br>Added default values to RTC Register Map" table 3<br>Updated flag register description in Register Map Detail" table 4<br>Changed C1, C2 values to 21pF, 21pF respectively<br>Changed I <sub>BAK</sub> value from 350 nA to 450 nA at hot temperature<br>Changed V <sub>RTCcap</sub> typical value from 2.4V to 3.0V<br>Referenced Note 15 to parameters t <sub>LZCE</sub> , t <sub>HZCE</sub> , t <sub>LZOE</sub> , t <sub>HZOE</sub> , t <sub>LZBE</sub> , t <sub>LZWE</sub> , t <sub>HZWE</sub> - and t <sub>HZBE</sub><br>Added footnote 24<br>Updated Figure 13 |
| *C   | 2733909 | 07/09/09        | GVCH/AESA       | Page 3; Added note to AutoStore Operation description<br>Page 4; Updated Hardware STORE (HSB) Operation description<br>Page 4; Updated Software STORE Operation description<br>Added best practices<br>Changed C1, C2 values to 10pF, 67pF respectively<br>Changed I <sub>BAK</sub> and V <sub>RTCcap</sub> parameter values<br>Added R <sub>BKCHG</sub> parameter<br>Updated V <sub>HDIS</sub> parameter description<br>Updated t <sub>DELAY</sub> parameter description<br>Updated footnote 28 and added footnote 35   |

## Sales, Solutions, and Legal Information

### Worldwide Sales and Design Support

Cypress maintains a worldwide network of offices, solution centers, manufacturer's representatives, and distributors. To find the office closest to you, visit us at [www.cypress.com/sales](http://www.cypress.com/sales).

### Products

|                  |  |
|------------------|--|
| PSoC             | <a href="http://psoc.cypress.com">psoc.cypress.com</a>         |
| Clocks & Buffers | <a href="http://clocks.cypress.com">clocks.cypress.com</a>     |
| Wireless         | <a href="http://wireless.cypress.com">wireless.cypress.com</a> |
| Memories         | <a href="http://memory.cypress.com">memory.cypress.com</a>     |
| Image Sensors    | <a href="http://image.cypress.com">image.cypress.com</a>       |

© Cypress Semiconductor Corporation, 2008-2009. The information contained herein is subject to change without notice. Cypress Semiconductor Corporation assumes no responsibility for the use of any circuitry other than circuitry embodied in a Cypress product. Nor does it convey or imply any license under patent or other rights. Cypress products are not warranted nor intended to be used for medical, life support, life saving, critical control or safety applications, unless pursuant to an express written agreement with Cypress. Furthermore, Cypress does not authorize its products for use as critical components in life-support systems where a malfunction or failure may reasonably be expected to result in significant injury to the user. The inclusion of Cypress products in life-support systems application implies that the manufacturer assumes all risk of such use and in doing so indemnifies Cypress against all charges.

Any Source Code (software and/or firmware) is owned by Cypress Semiconductor Corporation (Cypress) and is protected by and subject to worldwide patent protection (United States and foreign), United States copyright laws and international treaty provisions. Cypress hereby grants to licensee a personal, non-exclusive, non-transferable license to copy, use, modify, create derivative works of, and compile the Cypress Source Code and derivative works for the sole purpose of creating custom software and/or firmware in support of licensee product to be used only in conjunction with a Cypress integrated circuit as specified in the applicable agreement. Any reproduction, modification, translation, compilation, or representation of this Source Code except as specified above is prohibited without the express written permission of Cypress.

Disclaimer: CYPRESS MAKES NO WARRANTY OF ANY KIND, EXPRESS OR IMPLIED, WITH REGARD TO THIS MATERIAL, INCLUDING, BUT NOT LIMITED TO, THE IMPLIED WARRANTIES OF MERCHANTABILITY AND FITNESS FOR A PARTICULAR PURPOSE. Cypress reserves the right to make changes without further notice to the materials described herein. Cypress does not assume any liability arising out of the application or use of any product or circuit described herein. Cypress does not authorize its products for use as critical components in life-support systems where a malfunction or failure may reasonably be expected to result in significant injury to the user. The inclusion of Cypress' product in a life-support systems application implies that the manufacturer assumes all risk of such use and in doing so indemnifies Cypress against all charges.

Use may be limited by and subject to the applicable Cypress software license agreement.