

Model 6496 Modular Passive Oscilloscope Probe

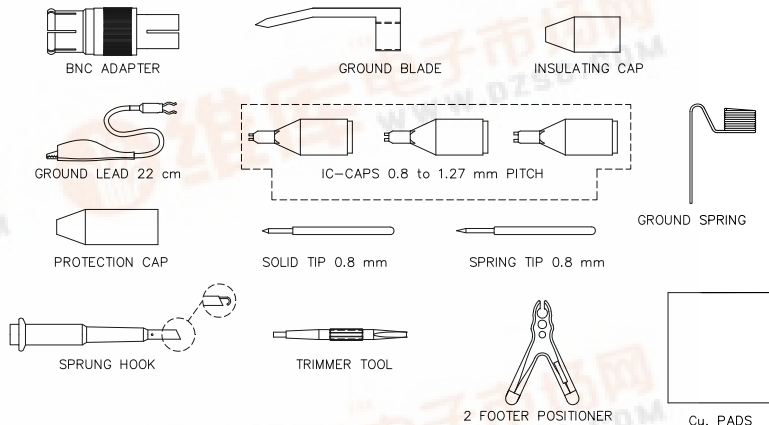

Model 6496
Modular Passive Oscilloscope Probe

Accessories included with Probe:



Features

- This probe is recommended for general purpose probing applications and is adjustable for low and high frequencies.
- The probe's entire core is made of a high quality ceramic hybrid.
- Pure coaxial design and laser trimmed resistors ensure highest signal fidelity along the signal path offering high bandwidth and fast risetimes for accurate impulse measurements.
- Probe tips are interchangeable and can be replaced easily.
- Accessories (one of each) included with Probe are:
 - BNC Adapter
 - Ground Blade
 - Ground Lead with Alligator Clip 22 cm (8.66")
 - Ground Spring
 - IC Caps: 0.8mm, 1.0mm, and 1.27mm pitch
 - Insulating Cap
 - Protection Cap
 - Solid Tip 0.8mm (0.0315")
 - Spring Tip 0.8mm (0.0315")
 - Sprung Hook
 - Trimmer Tool
 - 2 Footer Positioner
 - Copper (Cu) Pads

- Our passive probes are spring loaded, with needle sharp tips to support precise and safe measurements.

Specifications

Attenuation Ratio	10:1
Maximum Input Voltage CAT II¹	300 Vrms
Scope Bandwidth MHz	350
System Bandwidth MHz (-3 dB)	350
System Risetime (ns)	< 1
Probe Input Resistance (MΩ)	10
Probe Input Capacitance (pF)	< 14.5
Compensation Range (pF)	10 - 35
Cable Length	4 ft. (1.2 m)

¹ Rating: Per IEC 61010-031. Maximum voltage allowed on the low or ground connection including shell and housing must not exceed 30 V.

Ordering Information

Model: 6496

USA: Sales: 800-490-2361
Technical Support: technicalsupport@pomonatest.com
Fax: 425-446-5844

Europe: 31-(0) 40 2675 150 **International:** 425-446-5500

Where to Buy: www.pomonaelectronics.com

All dimensions are in inches. Tolerances (except noted): .xx = ±.02" (.51 mm), .xxx = ±.005" (.127 mm). All specifications are to the latest revisions. Specifications are subject to change without notice. Registered trademarks are the property of their respective companies.

