

# 0.05 $\mu$ V/ $^{\circ}$ C max, SINGLE-SUPPLY CMOS OPERATIONAL AMPLIFIERS Zero-Drift Series

## FEATURES

- LOW OFFSET VOLTAGE: 5 $\mu$ V (max)
- ZERO DRIFT: 0.05 $\mu$ V/ $^{\circ}$ C max
- QUIESCENT CURRENT: 750 $\mu$ A (max)
- SINGLE-SUPPLY OPERATION
- LOW BIAS CURRENT: 200pA (max)
- SHUTDOWN
- *Micro*SIZE PACKAGES
- WIDE SUPPLY RANGE: 2.7V to 12V

## APPLICATIONS

- TRANSDUCER APPLICATIONS
- TEMPERATURE MEASUREMENTS
- ELECTRONIC SCALES
- MEDICAL INSTRUMENTATION
- BATTERY-POWERED INSTRUMENTS
- HANDHELD TEST EQUIPMENT

## DESCRIPTION

The OPA734 and OPA735 series of CMOS operational amplifiers use auto-zeroing techniques to simultaneously provide low offset voltage (5 $\mu$ V max) and near-zero drift over time and temperature. These miniature, high-precision, low quiescent current amplifiers offer high input impedance and rail-to-rail output swing within 50mV of the rails. Either single or bipolar supplies can be used in the range of +2.7V to +12V ( $\pm$ 1.35V to  $\pm$ 6V). They are optimized for low-voltage, single-supply operation.

The OPA734 family includes a shutdown mode. Under logic control, the amplifiers can be switched from normal operation to a standby current that is 9 $\mu$ A (max) and the output placed in a high-impedance state.

The single version is available in the *Micro*SIZE SOT23-5 (SOT23-6 for shutdown version) and the SO-8 packages. The dual version is available in the MSOP-8 and SO-8 packages (MSOP-10 only for the shutdown version). All versions are specified for operation from  $-40^{\circ}$ C to  $+85^{\circ}$ C.

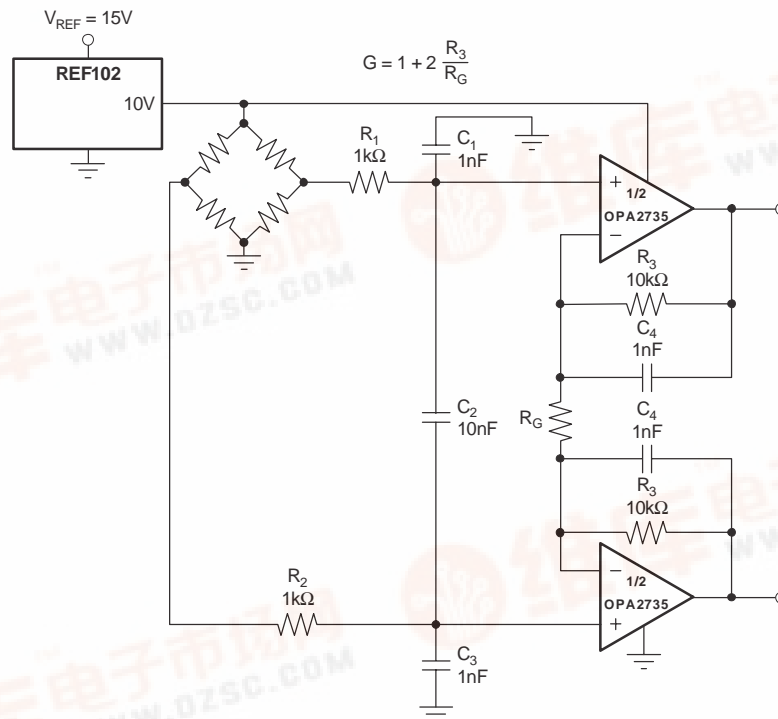

Please be aware that an important notice concerning availability, standard warranty, and use in critical applications of Texas Instruments semiconductor products and disclaimers thereto appears at the end of this data sheet.

All trademarks are the property of their respective owners.

PRODUCTION DATA: Information is current as of publication date. Products conform to specifications per the terms of Texas Instruments standard warranty. Production processing does not necessarily include testing of all parameters.



## ABSOLUTE MAXIMUM RATINGS(1)

Supply Voltage	+13.2V
Signal Input Terminals, Voltage <sup>(2)</sup>	(V-) - 0.5V to (V+) + 0.5V
Current <sup>(2)</sup>	±10mA
Output Short Circuit <sup>(3)</sup>	Continuous
Operating Temperature	-40°C to +150°C
Storage Temperature	-65°C to +150°C
Junction Temperature	+150°C
Lead Temperature (soldering, 10s)	+300°C
ESD Rating (Human Body Model), OPA734	1000V
ESD Rating (Human Body Model), OPA735, OPA2734, OPA2735	2000V



This integrated circuit can be damaged by ESD. Texas Instruments recommends that all integrated circuits be handled with appropriate precautions. Failure to observe proper handling and installation procedures can cause damage.

ESD damage can range from subtle performance degradation to complete device failure. Precision integrated circuits may be more susceptible to damage because very small parametric changes could cause the device not to meet its published specifications.

- (1) Stresses above these ratings may cause permanent damage. Exposure to absolute maximum conditions for extended periods may degrade device reliability. These are stress ratings only, and functional operation of the device at these or any other conditions beyond those specified is not implied.
- (2) Input terminals are diode-clamped to the power-supply rails. Input signals that can swing more than 0.5V beyond the supply rails should be current limited to 10mA or less.
- (3) Short-circuit to ground, one amplifier per package.

## PACKAGE/ORDERING INFORMATION(1)

PRODUCT	PACKAGE-LEAD	PACKAGE DESIGNATOR	SPECIFIED TEMPERATURE RANGE	PACKAGE MARKING	ORDERING NUMBER	TRANSPORT MEDIA, QUANTITY
<b>Shutdown Version</b>						
OPA734	SOT23-6	DBV	-40°C to +85°C	NSB	OPA734AIDBVT	Tape and Reel, 250
"	"	"	"	"	OPA734AIDBVR	Tape and Reel, 3000
OPA734	SO-8	D	-40°C to +85°C	OPA734A	OPA734AID	Rails, 100
"	"	"	"	"	OPA734AIDR	Tape and Reel, 2500
OPA2734	MSOP-10	DGS	-40°C to +85°C	BGO	OPA2734AIDGST	Tape and Reel, 250
"	"	"	"	"	OPA2734AIDGSR	Tape and Reel, 2500
<b>Non-Shutdown Version</b>						
OPA735	SOT23-5	DBV	-40°C to +85°C	NSC	OPA735AIDBVT	Tape and Reel, 250
"	"	"	"	"	OPA735AIDBVR	Tape and Reel, 3000
OPA735	SO-8	D	-40°C to +85°C	OPA735A	OPA735AID	Rails, 100
"	"	"	"	"	OPA735AIDR	Tape and Reel, 2500
OPA2735	SO-8	D	-40°C to +85°C	OPA2735A	OPA2735AID	Rails, 100
"	"	"	"	"	OPA2735AIDR	Tape and Reel, 2500
OPA2735	MSOP-8	DGK	-40°C to +85°C	BGN	OPA2735AIDGKT	Tape and Reel, 250
"	"	"	"	"	OPA2735AIDGKR	Tape and Reel, 2500

- (1) For the most current package and ordering information, see the Package Option Addendum at the end of this document, or see the TI website at [www.ti.com](http://www.ti.com).

**ELECTRICAL CHARACTERISTICS:  $V_S = \pm 5V$  ( $V_S = +10V$ )**

**Boldface** limits apply over the specified temperature range,  $T_A = -40^\circ\text{C}$  to  $+85^\circ\text{C}$ .

At  $T_A = +25^\circ\text{C}$ ,  $R_L = 10\text{k}\Omega$  connected to  $V_S/2$ , and  $V_{OUT} = V_S/2$ , unless otherwise noted.

PARAMETER	CONDITIONS	OPA734, OPA2734, OPA735, OPA2735			UNIT
		MIN	TYP	MAX	
<b>OFFSET VOLTAGE</b> Input Offset Voltage <b>vs Temperature</b> <b>vs Power Supply</b> Long-Term Stability Channel Separation, dc	$V_{OS}$ $dV_{OS}/dT$ PSRR  $V_S = 2.7V$ to $12V$ , $V_{CM} = 0V$		1 <b>0.01</b> 0.2 Note (1) 0.1	5 <b>0.05</b> 1.8	$\mu\text{V}$ $\mu\text{V}/^\circ\text{C}$ $\mu\text{V}/\text{V}$ $\mu\text{V}/\text{V}$
<b>INPUT BIAS CURRENT</b> Input Bias Current <b>over Temperature</b> Input Offset Current	$I_B$ $V_{CM} = V_S/2$ $I_{OS}$ $V_{CM} = V_S/2$		See Typical Characteristics		pA pA pA
<b>NOISE</b> Input Voltage Noise, $f = 0.01\text{Hz}$ to $1\text{Hz}$ Input Voltage Noise, $f = 0.1\text{Hz}$ to $10\text{Hz}$ Input Voltage Noise Density, $f = 1\text{kHz}$ Input Current Noise Density, $f = 1\text{kHz}$	$e_n$ $e_n$ $e_n$ $i_n$		0.8 2.5 135 40		$\mu\text{V}_{PP}$ $\mu\text{V}_{PP}$ $\text{nV}/\sqrt{\text{Hz}}$ $\text{fA}/\sqrt{\text{Hz}}$
<b>INPUT VOLTAGE RANGE</b> Common-Mode Voltage Range Common-Mode Rejection Ratio	$V_{CM}$ CMRR  $(V^-) - 0.1V < V_{CM} < (V^+) - 1.5V$	$(V^-) - 0.1$ 115	130	$(V^+) - 1.5$	V dB
<b>INPUT CAPACITANCE</b> Differential Common-Mode			2 10		pF pF
<b>OPEN-LOOP GAIN</b> Open-Loop Voltage Gain	$A_{OL}$  $(V^-) + 100\text{mV} < V_O < (V^+) - 100\text{mV}$	115	130		dB
<b>FREQUENCY RESPONSE</b> Gain-Bandwidth Product Slew Rate	GBW SR  $G = +1$		1.6 1.5		MHz V/ $\mu\text{s}$
<b>OUTPUT</b> Voltage Output Swing from Rail Short-Circuit Current Open-Loop Output Impedance Capacitive Load Drive	$I_{SC}$  $R_L = 10\text{k}\Omega$  $f = 1\text{MHz}$ , $I_O = 0$ $C_{LOAD}$		20 $\pm 20$ 125	50	mV mA $\Omega$
<b>ENABLE/SHUTDOWN</b> $t_{OFF}$ $t_{ON}^{(2)}$ $V_L$ (amplifier is shutdown) $V_H$ (amplifier is active) $I_{QSD}$ (per amplifier) Input Bias Current of Enable Pin		$V^-$ $(V^-) + 2$	1.5 150 4 3	$(V^-) + 0.8$ $V^+$ 9	$\mu\text{s}$ $\mu\text{s}$ V V $\mu\text{A}$ $\mu\text{A}$
<b>POWER SUPPLY</b> Operating Voltage Range Quiescent Current (per amplifier)	$V_S$  $I_Q$  $I_Q = 0$		2.7 to 12 ( $\pm 1.35$ to $\pm 6$ ) <b>0.6</b>		V mA
<b>TEMPERATURE RANGE</b> Specified Range Operating Range Storage Range Thermal Resistance SOT23-5, SOT23-6 MSOP-8, MSOP-10, SO-8	$\theta_{JA}$	-40 -40 -65		+85 +150 +150	$^\circ\text{C}$ $^\circ\text{C}$ $^\circ\text{C}$ $^\circ\text{C}/\text{W}$ $^\circ\text{C}/\text{W}$ $^\circ\text{C}/\text{W}$

(1) 300-hour life test at  $150^\circ\text{C}$  demonstrated randomly distributed variation in the range of measurement limits—approximately  $1\mu\text{V}$ .

(2) Device requires one complete auto-zero cycle to return to  $V_{OS}$  accuracy.

PIN CONFIGURATIONS

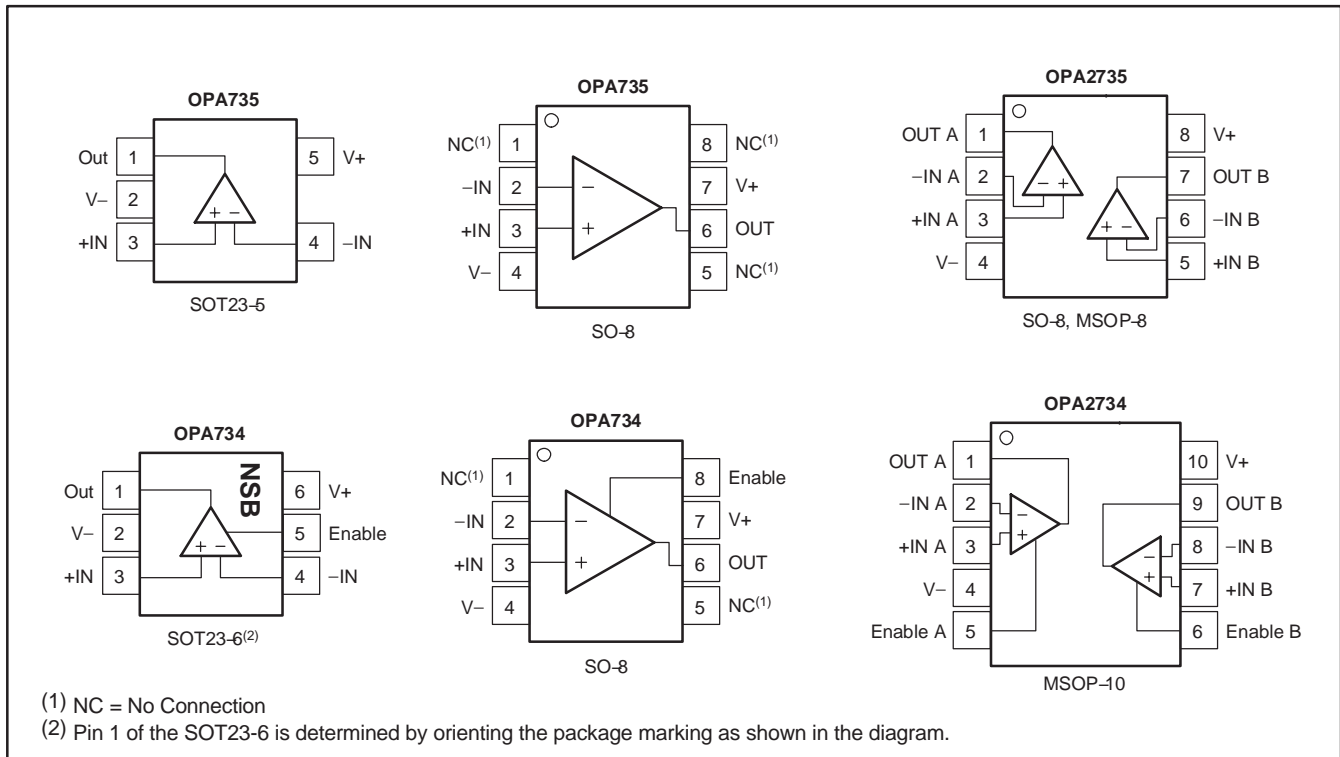

## TYPICAL CHARACTERISTICS

At  $T_A = +25^\circ\text{C}$ ,  $V_S = \pm 5\text{V}$  (same as  $+10\text{V}$ ).

OUTPUT VOLTAGE PRODUCTION DISTRIBUTION

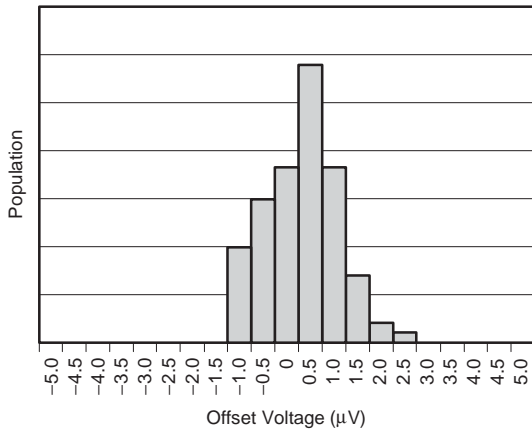

OUTPUT VOLTAGE DRIFT PRODUCTION DISTRIBUTION

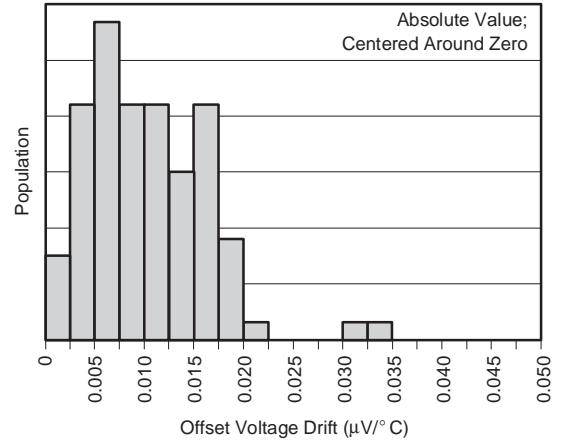

OUTPUT VOLTAGE SWING TO RAIL  
vs OUTPUT CURRENT

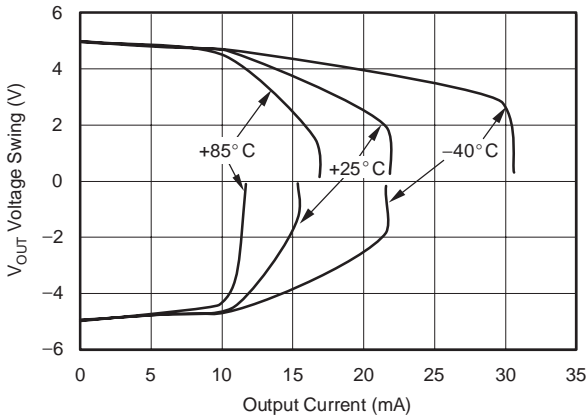

INPUT BIAS CURRENT vs TEMPERATURE

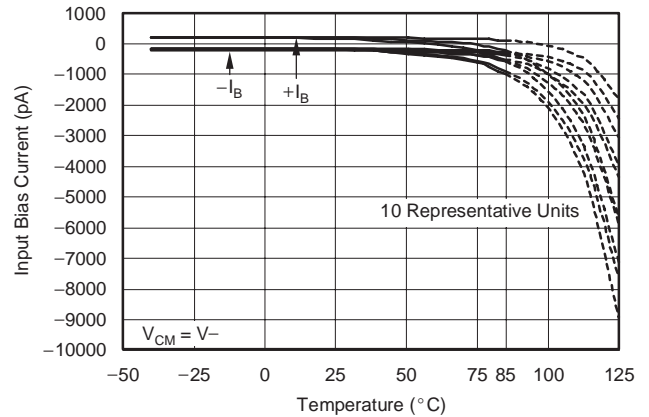

INPUT BIAS CURRENT vs TEMPERATURE

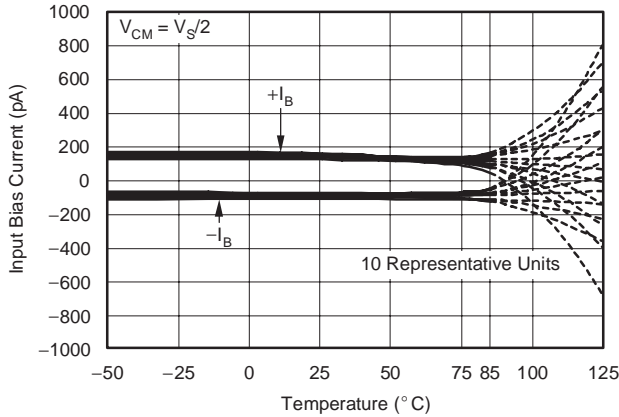

SUPPLY CURRENT vs TEMPERATURE

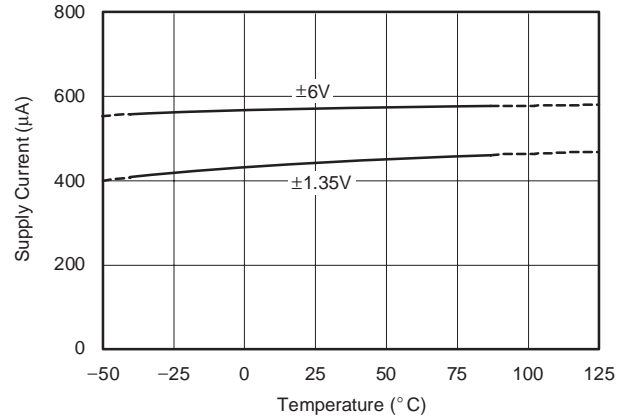

**TYPICAL CHARACTERISTICS (continued)**

At  $T_A = +25^\circ\text{C}$ ,  $V_S = \pm 5\text{V}$  (same as +10V).

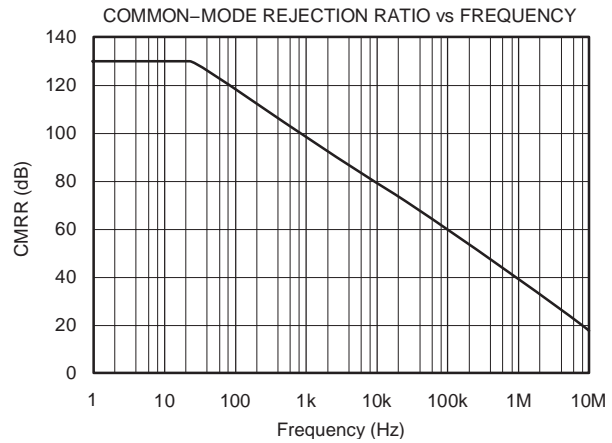
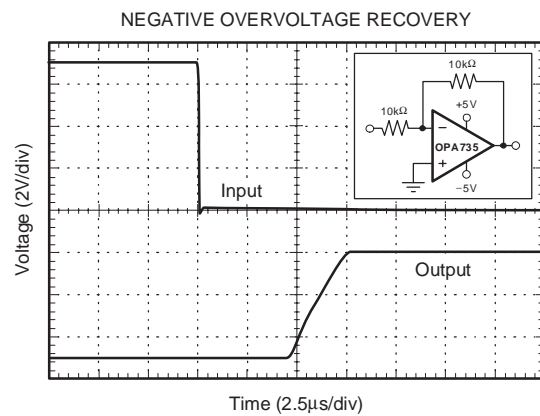
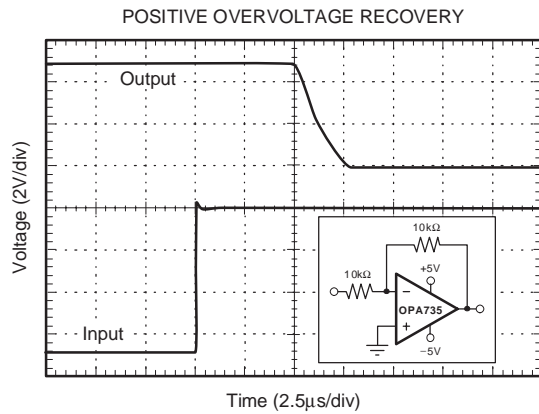
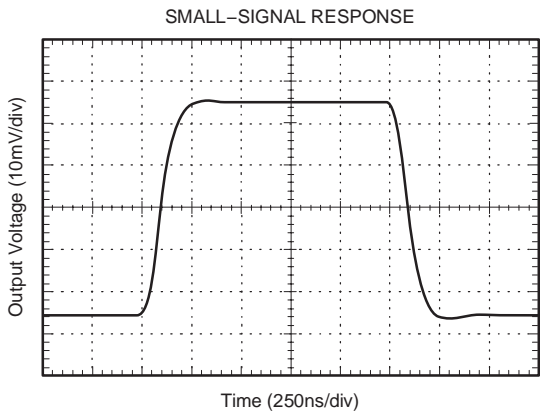
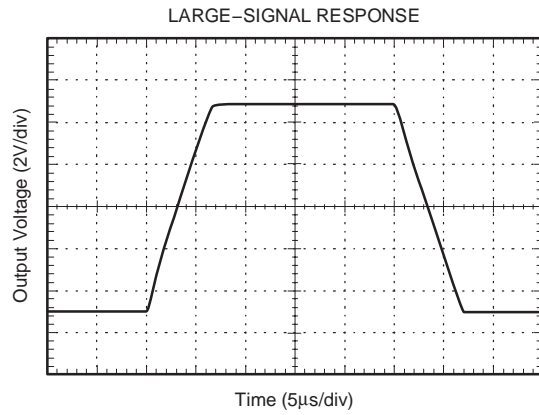
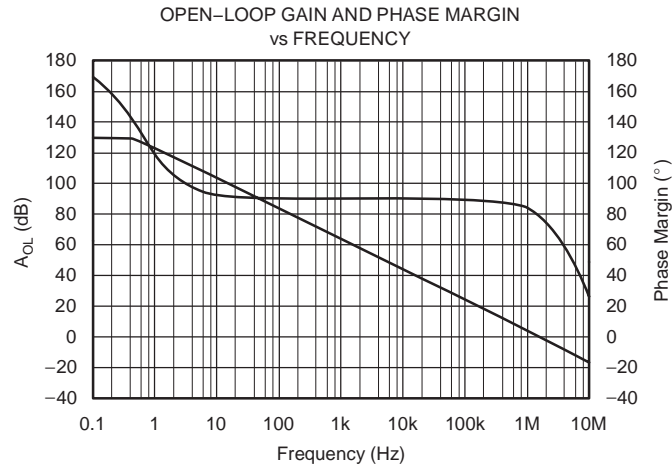

## TYPICAL CHARACTERISTICS (continued)

At  $T_A = +25^\circ\text{C}$ ,  $V_S = \pm 5\text{V}$  (same as  $+10\text{V}$ ).

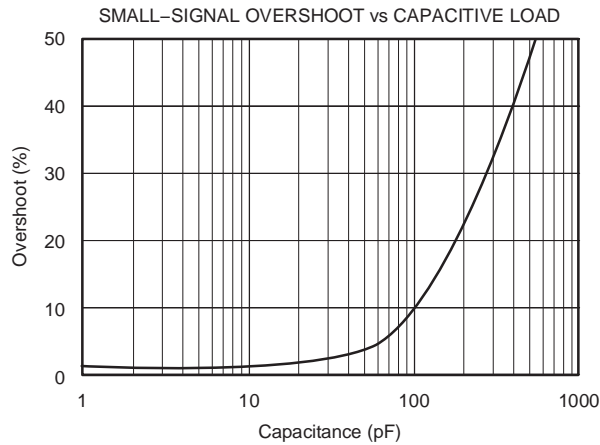
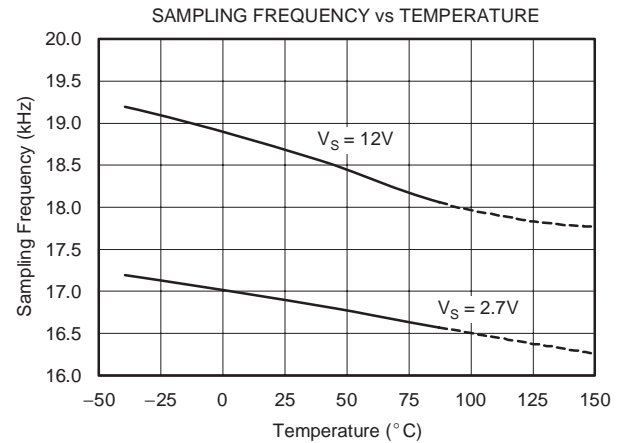
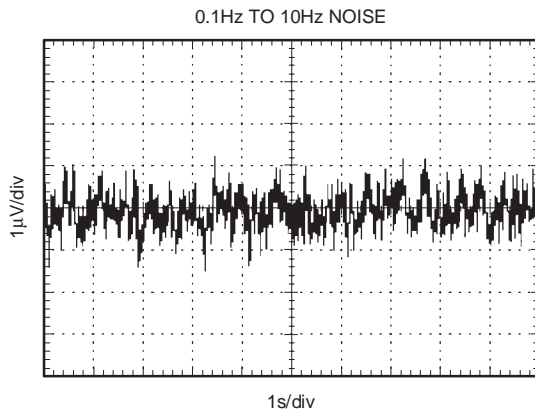
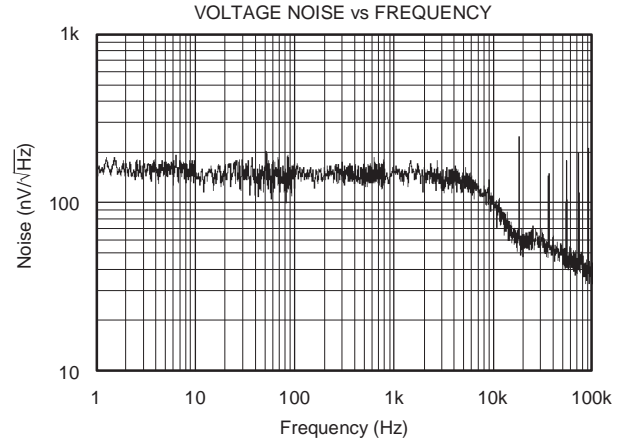
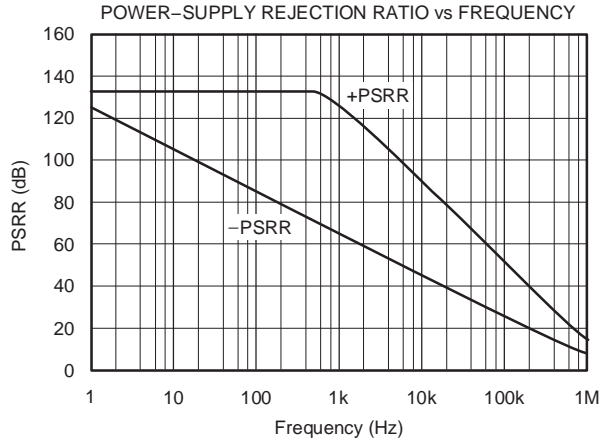

## APPLICATIONS INFORMATION

The OPA734 and OPA735 series of op amps are unity-gain stable and free from unexpected output phase reversal. They use auto-zeroing techniques to provide low offset voltage and demonstrate very low drift over time and temperature.

Good layout practice mandates the use of a 0.1- $\mu$ F capacitor placed closely across the supply pins.

For lowest offset voltage and precision performance, circuit layout and mechanical conditions should be optimized. Avoid temperature gradients that create thermoelectric (Seebeck) effects in thermocouple junctions formed from connecting dissimilar conductors. These thermally-generated potentials can be made to cancel by assuring that they are equal on both input terminals:

1. Use low thermoelectric-coefficient connections (avoid dissimilar metals).
2. Thermally isolate components from power supplies or other heat sources.
3. Shield op amp and input circuitry from air currents such as cooling fans.

Following these guidelines will reduce the likelihood of junctions being at different temperatures, which can cause thermoelectric voltages of 0.1- $\mu$ V/ $^{\circ}$ C or higher, depending on the materials used.

## OPERATING VOLTAGE

The OPA734 and OPA735 op amp family operates with a power-supply range of +2.7V to +12V ( $\pm$ 1.35V to  $\pm$ 6V). Supply voltages higher than +13.2V (absolute maximum) can permanently damage the amplifier. Parameters that vary over supply voltage or temperature are shown in the Typical Characteristics section of this data sheet.

## OPA734 ENABLE FUNCTION

The enable/shutdown digital input is referenced to the  $V_{-}$  supply voltage of the op amp. A logic HIGH enables the op amp. A valid logic HIGH is defined as  $> (V_{-}) + 2V$ . The valid logic HIGH signal can be up to the positive supply, independent of the negative power supply voltage. A valid logic LOW is defined as  $< 0.8V$  above the  $V_{-}$  supply pin. If dual or split power supplies are used, be sure that logic input signals are properly referred to the negative supply voltage. The Enable pin is connected to internal pull-up circuitry and will enable the device if this pin is left open circuit.

The logic input is a CMOS input. Separate logic inputs are provided for each op amp on the dual version. For battery-operated applications, this feature can be used to greatly reduce the average current and extend battery life.

The enable time is 150- $\mu$ s, which includes one full auto-zero cycle required by the amplifier to return to  $V_{OS}$  accuracy. Prior to returning to full accuracy, the amplifier may function properly, but with unspecified offset voltage.

Disable time is 1.5- $\mu$ s. When disabled, the output assumes a high-impedance state. The disable state allows the OPA734 to be operated as a gated amplifier, or to have the output multiplexed onto a common analog output bus.

## INPUT VOLTAGE

The input common-mode range extends from  $(V_{-}) - 0.1V$  to  $(V_{+}) - 1.5V$ . For normal operation, the inputs must be limited to this range. The common-mode rejection ratio is only valid within the specified input common-mode range. A lower supply voltage results in lower input common-mode range; therefore, attention to these values must be given when selecting the input bias voltage. For example, when operating on a single 3V power supply, common-mode range is from 0.1V below ground to half the power-supply voltage.

Normally, input bias current is approximately 100pA; however, input voltages exceeding the power supplies can cause excessive current to flow in or out of the input pins. Momentary voltages greater than the power supply can be tolerated if the input current is limited to 10mA. This is easily accomplished with an input resistor, as shown in Figure 1.

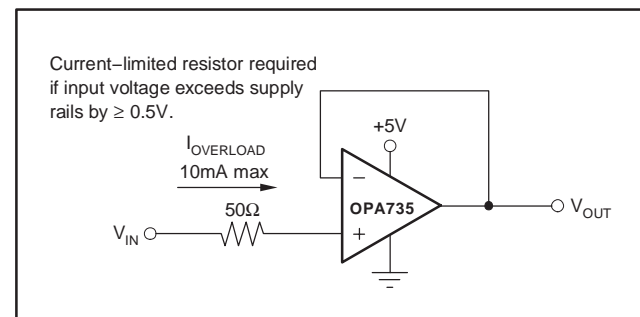

Figure 1. Input Current Protection

## INTERNAL OFFSET CORRECTION

The OPA734 and OPA735 series of op amps use an auto-zero topology with a time-continuous 1.6MHz op amp in the signal path. This amplifier is zero-corrected every 100- $\mu$ s using a proprietary technique. Upon power-up, the amplifier requires one full auto-zero cycle of approximately 100- $\mu$ s in addition to the start-up time for the bias circuitry to achieve specified  $V_{OS}$  accuracy. Prior to this time, the amplifier may function properly but with unspecified offset voltage.



查询"OPA734"供应商

Low-gain (< 20) operation demands that the auto-zero circuitry correct for common-mode rejection errors of the main amplifier. Because these errors can be larger than 0.1% of a full-scale input step change, one calibration cycle (100μs) can be required to achieve full accuracy.

The term *clock feedthrough* describes the presence of the clock frequency in the output spectrum. In auto-zeroed op amps, clock feedthrough may result from the settling of the internal sampling capacitor, or from the small amount of charge injection that occurs during the sample-and-hold of the op amp offset voltage. Feedthrough can be minimized by keeping the source impedance relatively low (< 1kΩ) and matching the source impedance on both input terminals. If the source resistance is high (> 1kΩ) feedthrough can generally be reduced with a capacitor of 1nF or greater in parallel with the source or feedback resistors. See the circuit application examples.

**LAYOUT GUIDELINES**

Attention to good layout practices is always recommended. Keep traces short. When possible, use a PCB ground plane with surface-mount components placed as close to the device pins as possible. Place a 0.1μF capacitor closely across the supply pins. These guidelines should be applied throughout the analog circuit to improve performance and provide benefits such as reducing the electromagnetic-interference (EMI) susceptibility.

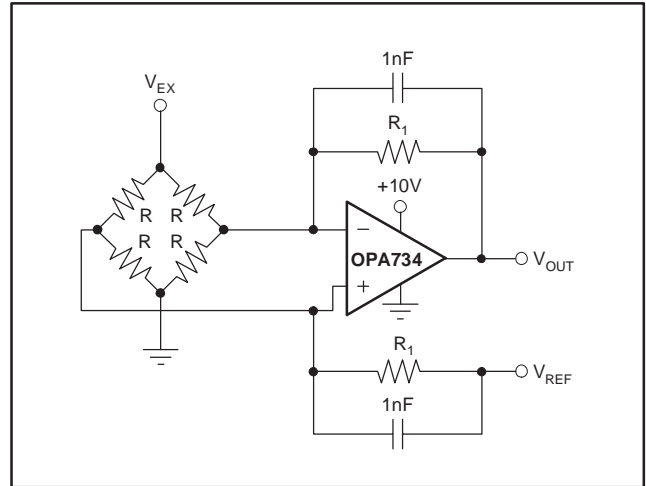

**Figure 2. Single Op Amp Bridge Amplifier Circuit**

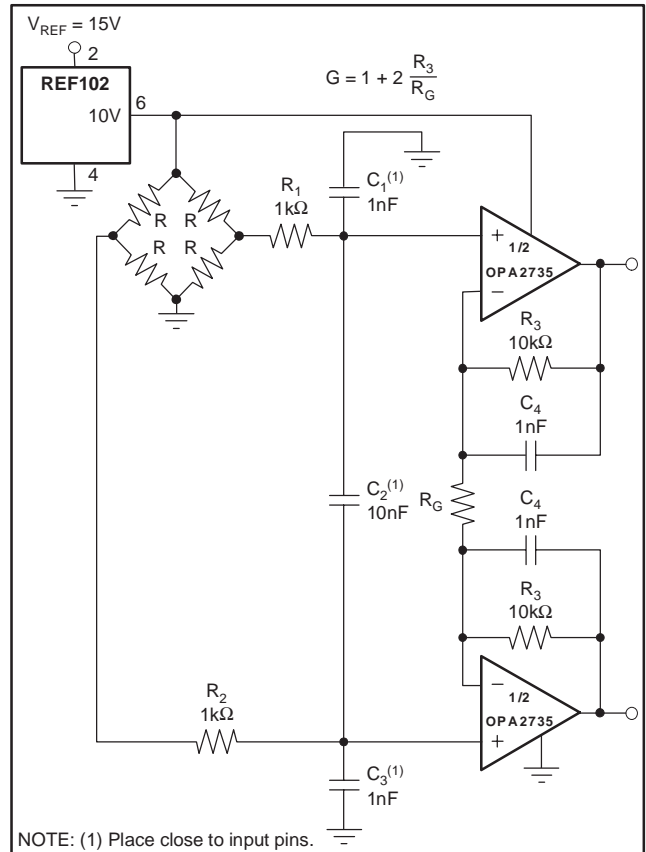

NOTE: (1) Place close to input pins.

**Figure 3. Differential Output Bridge Amplifier**

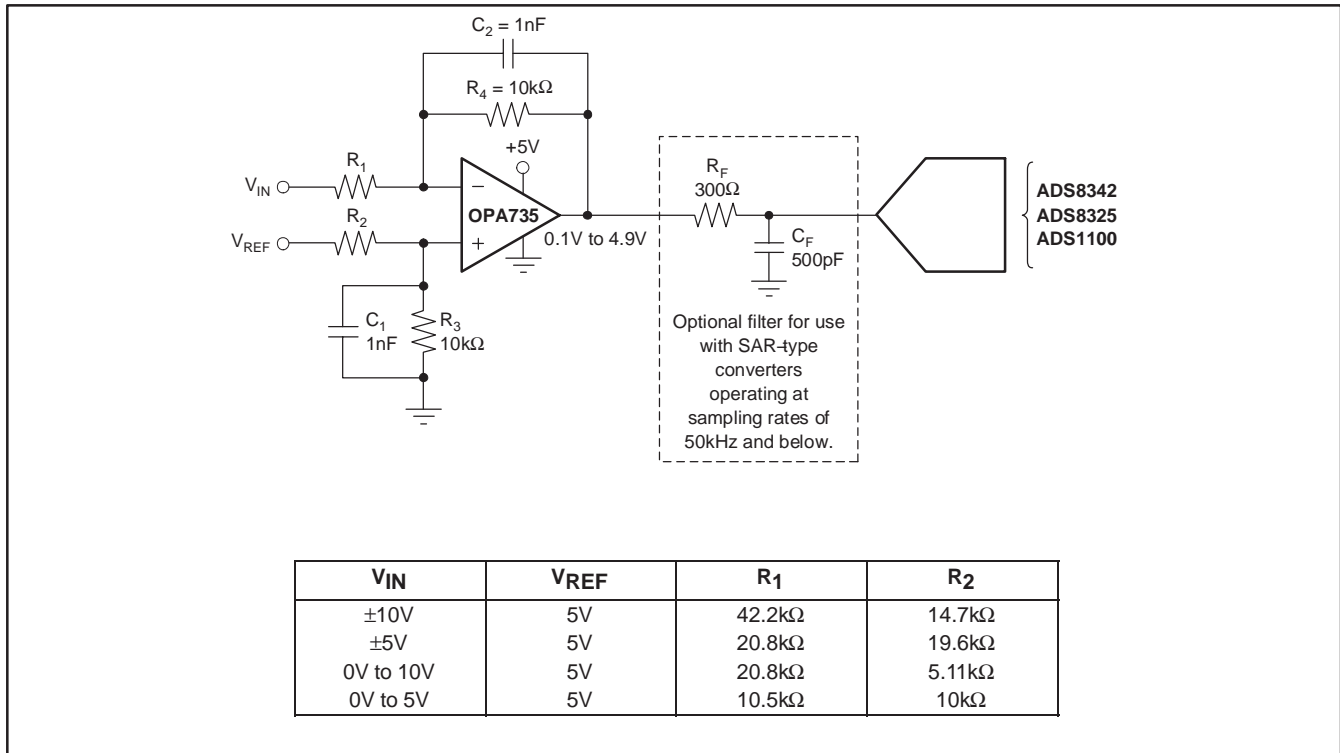

Figure 4. Driving ADC

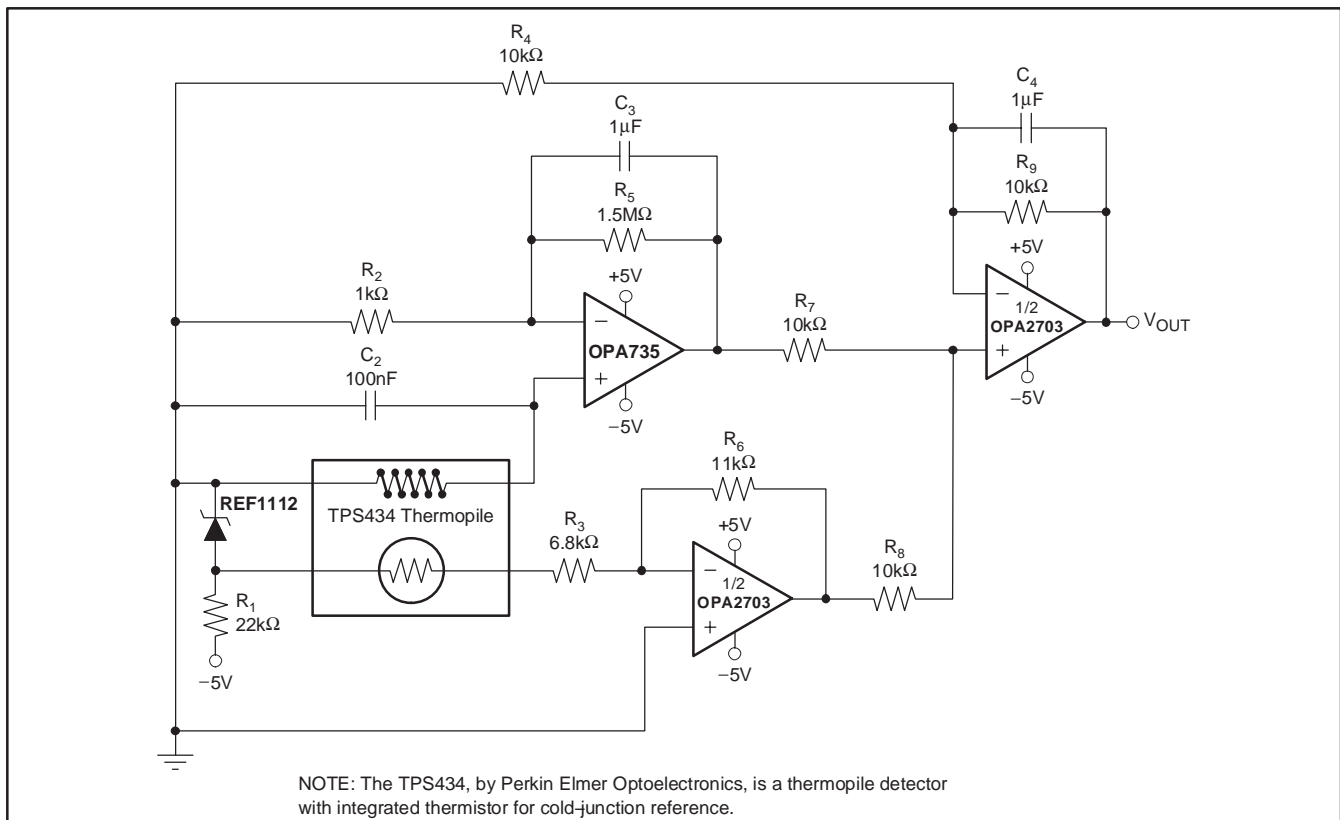

Figure 5. Thermopile Non-Contact Surface Temperature Measurement

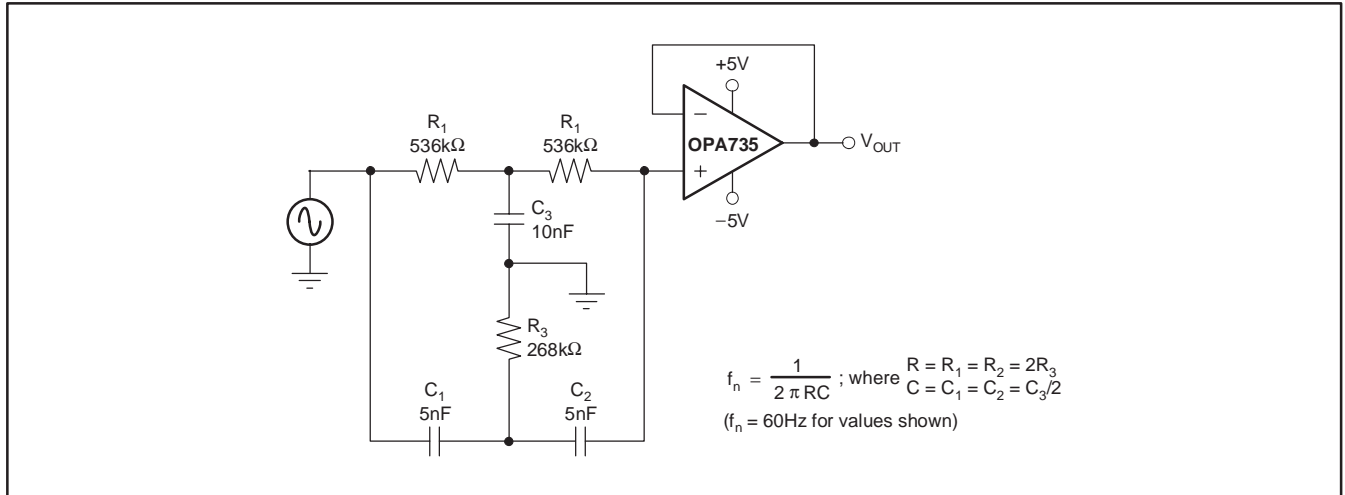

Figure 6. Twin-T Notch Filter

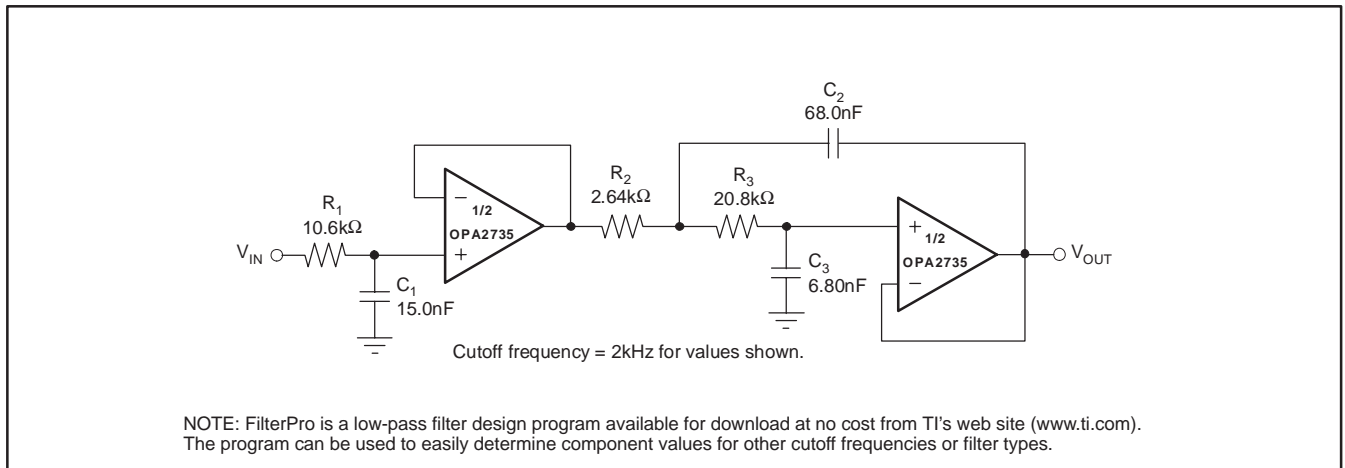

Figure 7. High DC Accuracy, 3-Pole Low-Pass Filter

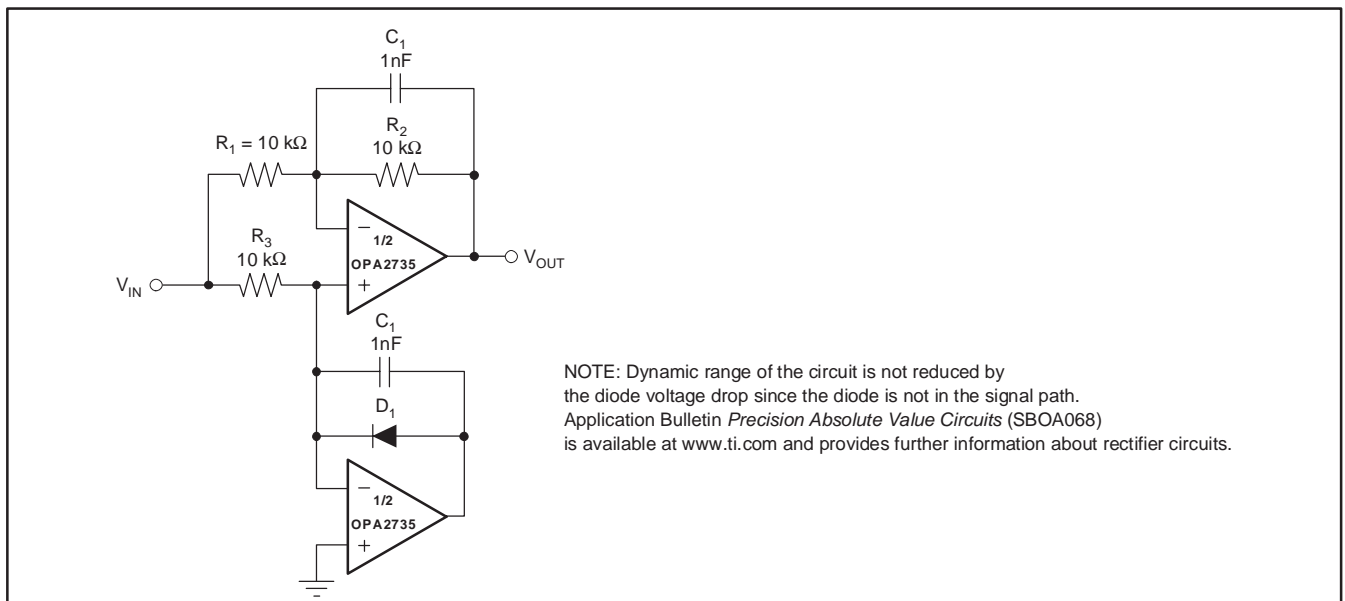

Figure 8. Precision Full-Wave Rectifier with Full Dynamic Range

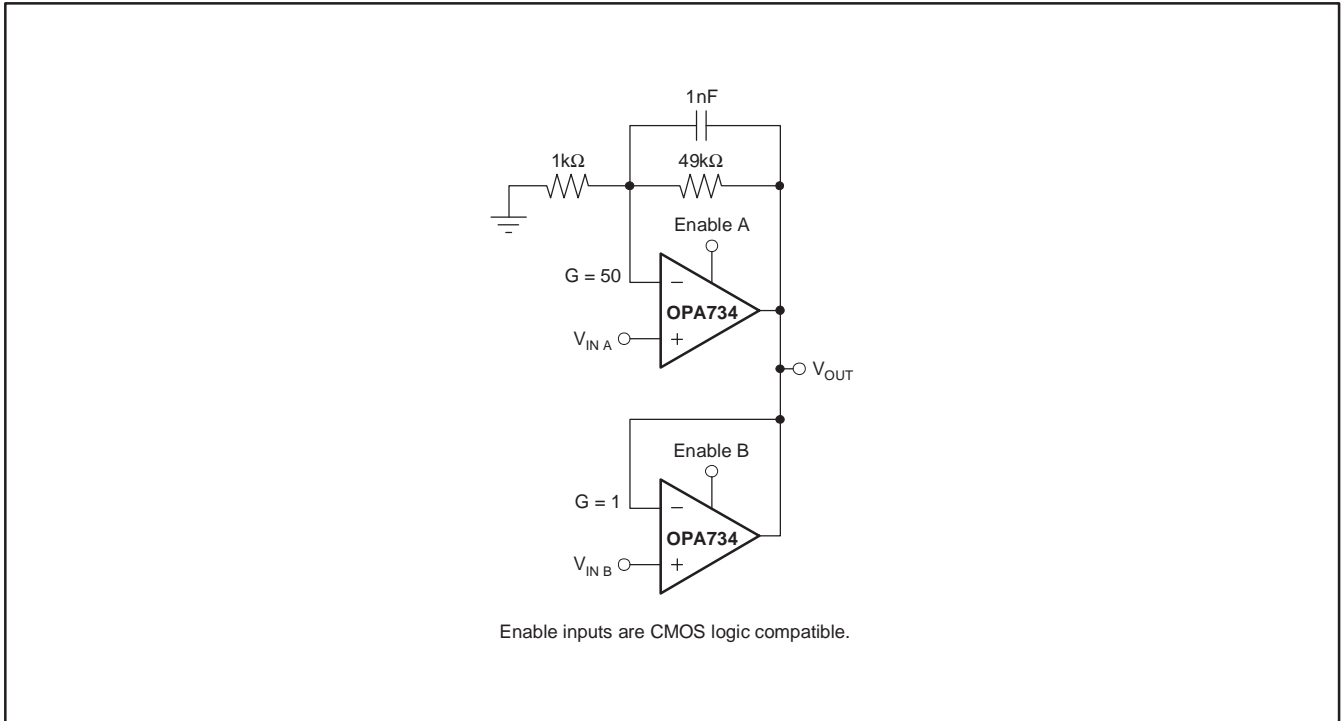

Figure 9. High-Precision 2-Input MUX for Programmable Gain

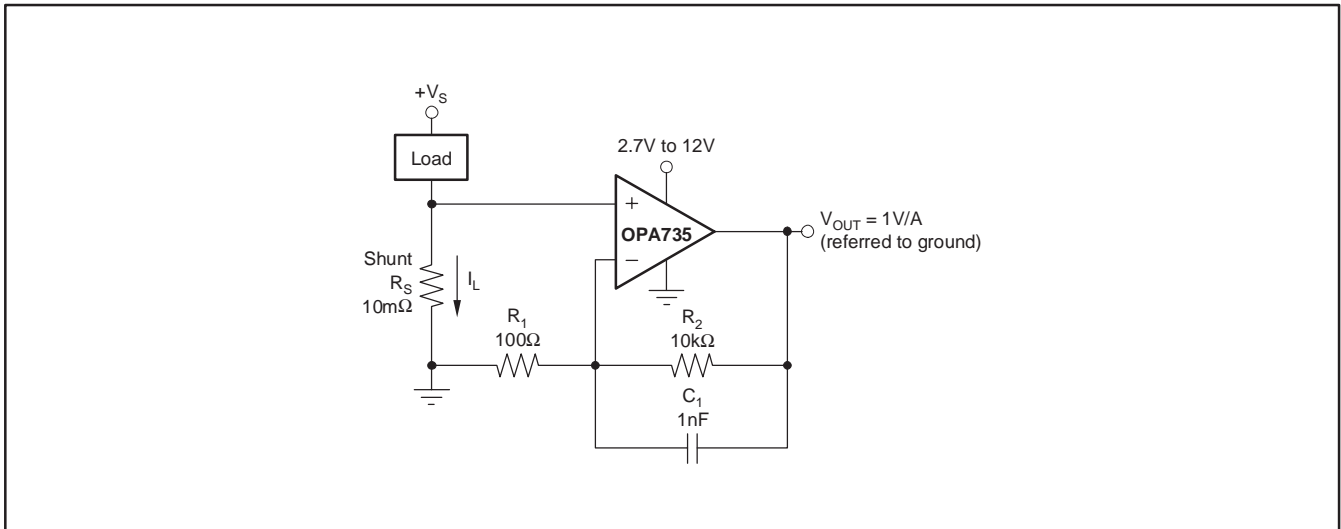

Figure 10. Low-Side Power-Supply Current Sensing



www.ti.com

PACKAG

**PACKAGING INFORMATION**

Orderable Device	Status <sup>(1)</sup>	Package Type	Package Drawing	Pins	Package Qty	Eco Plan <sup>(2)</sup>	Lead/ Ball Finish	MSL Peak
OPA2734AIDGSR	ACTIVE	MSOP	DGS	10	2500	Green (RoHS & no Sb/Br)	CU NIPDAU	Level-2-2600
OPA2734AIDGSRG4	ACTIVE	MSOP	DGS	10	2500	Green (RoHS & no Sb/Br)	CU NIPDAU	Level-2-2600
OPA2734AIDGST	ACTIVE	MSOP	DGS	10	250	Green (RoHS & no Sb/Br)	CU NIPDAU	Level-2-2600
OPA2734AIDGSTG4	ACTIVE	MSOP	DGS	10	250	Green (RoHS & no Sb/Br)	CU NIPDAU	Level-2-2600
OPA2735AID	ACTIVE	SOIC	D	8	75	Green (RoHS & no Sb/Br)	CU NIPDAU	Level-2-2600
OPA2735AIDG4	ACTIVE	SOIC	D	8	75	Green (RoHS & no Sb/Br)	CU NIPDAU	Level-2-2600
OPA2735AIDGKR	ACTIVE	MSOP	DGK	8	2500	Green (RoHS & no Sb/Br)	CU NIPDAU	Level-2-2600
OPA2735AIDGKRG4	ACTIVE	MSOP	DGK	8	2500	Green (RoHS & no Sb/Br)	CU NIPDAU	Level-2-2600
OPA2735AIDGKT	ACTIVE	MSOP	DGK	8	250	Green (RoHS & no Sb/Br)	CU NIPDAU	Level-2-2600
OPA2735AIDGKTG4	ACTIVE	MSOP	DGK	8	250	Green (RoHS & no Sb/Br)	CU NIPDAU	Level-2-2600
OPA2735AIDR	ACTIVE	SOIC	D	8	2500	Green (RoHS & no Sb/Br)	CU NIPDAU	Level-2-2600
OPA2735AIDRG4	ACTIVE	SOIC	D	8	2500	Green (RoHS & no Sb/Br)	CU NIPDAU	Level-2-2600
OPA734AID	ACTIVE	SOIC	D	8	75	Green (RoHS & no Sb/Br)	CU NIPDAU	Level-2-2600
OPA734AIDBVR	ACTIVE	SOT-23	DBV	6	3000	Green (RoHS & no Sb/Br)	CU NIPDAU	Level-2-2600
OPA734AIDBVRG4	ACTIVE	SOT-23	DBV	6	3000	Green (RoHS & no Sb/Br)	CU NIPDAU	Level-2-2600
OPA734AIDBVT	ACTIVE	SOT-23	DBV	6	250	Green (RoHS & no Sb/Br)	CU NIPDAU	Level-2-2600
OPA734AIDBVTG4	ACTIVE	SOT-23	DBV	6	250	Green (RoHS & no Sb/Br)	CU NIPDAU	Level-2-2600



www.ti.com

PACKAG

Orderable Device	Status <sup>(1)</sup>	Package Type	Package Drawing	Pins	Package Qty	Eco Plan <sup>(2)</sup>	Lead/Ball Finish	MSL Peak
OPA734AIDG4	ACTIVE	SOIC	D	8	75	Green (RoHS & no Sb/Br)	CU NIPDAU	Level-2-2600
OPA735AID	ACTIVE	SOIC	D	8	75	Green (RoHS & no Sb/Br)	CU NIPDAU	Level-2-2600
OPA735AIDBVR	ACTIVE	SOT-23	DBV	5	3000	Green (RoHS & no Sb/Br)	CU NIPDAU	Level-2-2600
OPA735AIDBVRG4	ACTIVE	SOT-23	DBV	5	3000	Green (RoHS & no Sb/Br)	CU NIPDAU	Level-2-2600
OPA735AIDBVT	ACTIVE	SOT-23	DBV	5	250	Green (RoHS & no Sb/Br)	CU NIPDAU	Level-2-2600
OPA735AIDBVTG4	ACTIVE	SOT-23	DBV	5	250	Green (RoHS & no Sb/Br)	CU NIPDAU	Level-2-2600
OPA735AIDG4	ACTIVE	SOIC	D	8	75	Green (RoHS & no Sb/Br)	CU NIPDAU	Level-2-2600
OPA735AIDR	ACTIVE	SOIC	D	8	2500	Green (RoHS & no Sb/Br)	CU NIPDAU	Level-2-2600
OPA735AIDRG4	ACTIVE	SOIC	D	8	2500	Green (RoHS & no Sb/Br)	CU NIPDAU	Level-2-2600

<sup>(1)</sup> The marketing status values are defined as follows:

**ACTIVE:** Product device recommended for new designs.

**LIFEBUY:** TI has announced that the device will be discontinued, and a lifetime-buy period is in effect.

**NRND:** Not recommended for new designs. Device is in production to support existing customers, but TI does not recommend using this part in a new design.

**PREVIEW:** Device has been announced but is not in production. Samples may or may not be available.

**OBSELETE:** TI has discontinued the production of the device.

<sup>(2)</sup> Eco Plan - The planned eco-friendly classification: Pb-Free (RoHS), Pb-Free (RoHS Exempt), or Green (RoHS & no Sb/Br) - please check <http://www.ti.com> for more information and additional product content details.

**TBD:** The Pb-Free/Green conversion plan has not been defined.

**Pb-Free (RoHS):** TI's terms "Lead-Free" or "Pb-Free" mean semiconductor products that are compatible with the current RoHS requirements for all RoHS materials, with the exception of lead (Pb), which may not exceed 0.1% by weight in homogeneous materials. Where designed to be soldered at high temperatures, TI Pb-Free products are suitable for use in applications that require high temperature soldering processes.

**Pb-Free (RoHS Exempt):** This component has a RoHS exemption for either 1) lead-based flip-chip solder bumps used between the die and package, or 2) lead-based leadframe materials used in the die and leadframe. The component is otherwise considered Pb-Free (RoHS compatible) as defined above.

**Green (RoHS & no Sb/Br):** TI defines "Green" to mean Pb-Free (RoHS compatible), and free of Bromine (Br) and Antimony (Sb) based flame retardants (as defined in homogeneous material).

<sup>(3)</sup> MSL, Peak Temp. -- The Moisture Sensitivity Level rating according to the JEDEC industry standard classifications, and peak solder temperature.

[查询"OPA734"供应商](#)



[www.ti.com](http://www.ti.com)

PACKAG

---

**Important Information and Disclaimer:** The information provided on this page represents TI's knowledge and belief as of the date that it is provided. TI does not warrant the accuracy of the information provided by third parties, and makes no representation or warranty as to the accuracy of such information. Efforts are underway to better integrate information from third parties and TI continues to take reasonable steps to provide representative and accurate information but may not have conducted destructive testing or chemical analysis on all samples. TI and TI suppliers consider certain information to be proprietary, and thus CAS numbers and other limited information may not be available for release.

In no event shall TI's liability arising out of such information exceed the total purchase price of the TI part(s) at issue in this document sold by TI to Customer.

TAPE AND REEL INFORMATION

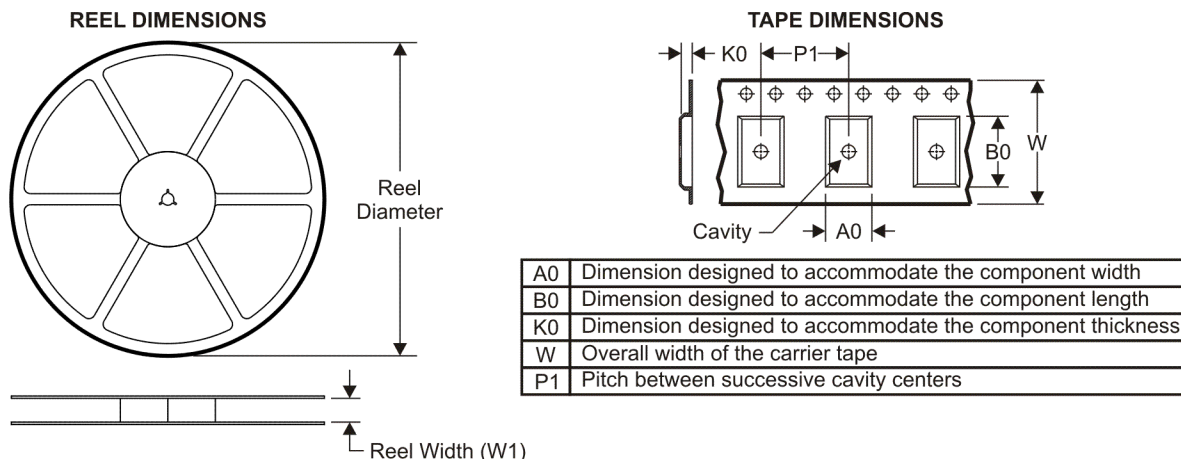

QUADRANT ASSIGNMENTS FOR PIN 1 ORIENTATION IN TAPE

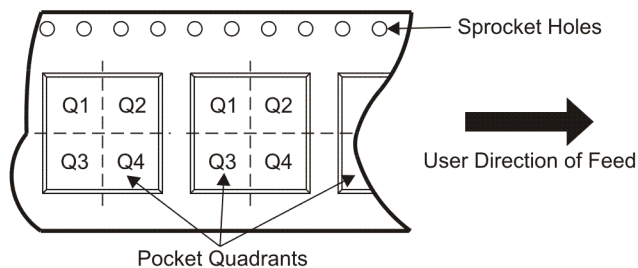

\*All dimensions are nominal

Device	Package Type	Package Drawing	Pins	SPQ	Reel Diameter (mm)	Reel Width W1 (mm)	A0 (mm)	B0 (mm)	K0 (mm)	P1 (mm)	W (mm)	Pin1 Quadrant
OPA2734AIDGSR	MSOP	DGS	10	2500	330.0	12.4	5.3	3.4	1.4	8.0	12.0	Q1
OPA2734AIDGST	MSOP	DGS	10	250	180.0	12.4	5.3	3.4	1.4	8.0	12.0	Q1
OPA2735AIDGKR	MSOP	DGK	8	2500	330.0	12.4	5.3	3.4	1.4	8.0	12.0	Q1
OPA2735AIDGKT	MSOP	DGK	8	250	180.0	12.4	5.3	3.4	1.4	8.0	12.0	Q1
OPA2735AIDR	SOIC	D	8	2500	330.0	12.4	6.4	5.2	2.1	8.0	12.0	Q1
OPA734AIDBVR	SOT-23	DBV	6	3000	180.0	8.4	3.2	3.1	1.39	4.0	8.0	Q3
OPA734AIDBVT	SOT-23	DBV	6	250	180.0	8.4	3.2	3.1	1.39	4.0	8.0	Q3
OPA735AIDBVR	SOT-23	DBV	5	3000	180.0	8.4	3.2	3.1	1.39	4.0	8.0	Q3
OPA735AIDBVT	SOT-23	DBV	5	250	180.0	8.4	3.2	3.1	1.39	4.0	8.0	Q3
OPA735AIDR	SOIC	D	8	2500	330.0	12.4	6.4	5.2	2.1	8.0	12.0	Q1



**TAPE AND REEL BOX DIMENSIONS**

\*All dimensions are nominal

Device	Package Type	Package Drawing	Pins	SPQ	Length (mm)	Width (mm)	Height (mm)
OPA2734AIDGSR	MSOP	DGS	10	2500	346.0	346.0	29.0
OPA2734AIDGST	MSOP	DGS	10	250	190.5	212.7	31.8
OPA2735AIDGKR	MSOP	DGK	8	2500	346.0	346.0	29.0
OPA2735AIDGKT	MSOP	DGK	8	250	190.5	212.7	31.8
OPA2735AIDR	SOIC	D	8	2500	346.0	346.0	29.0
OPA734AIDBVR	SOT-23	DBV	6	3000	190.5	212.7	31.8
OPA734AIDBVT	SOT-23	DBV	6	250	190.5	212.7	31.8
OPA735AIDBVR	SOT-23	DBV	5	3000	190.5	212.7	31.8
OPA735AIDBVT	SOT-23	DBV	5	250	190.5	212.7	31.8
OPA735AIDR	SOIC	D	8	2500	346.0	346.0	29.0

## DBV (R-PDSO-G5)

## PLASTIC SMALL-OUTLINE PACKAGE

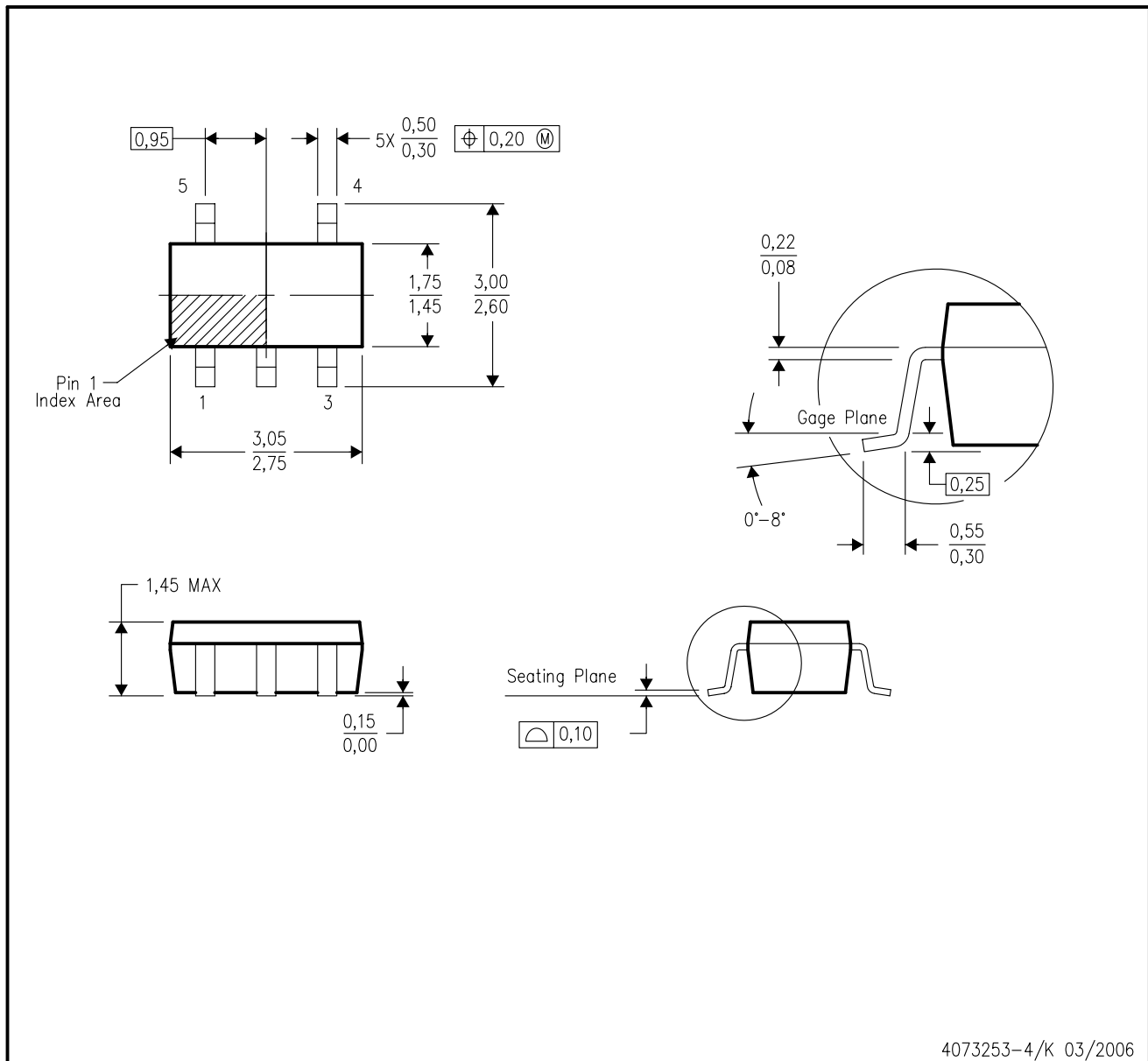

- NOTES:
- All linear dimensions are in millimeters.
  - This drawing is subject to change without notice.
  - Body dimensions do not include mold flash or protrusion. Mold flash and protrusion shall not exceed 0.15 per side.
  - Falls within JEDEC MO-178 Variation AA.

## DBV (R-PDSO-G6)

## PLASTIC SMALL-OUTLINE PACKAGE

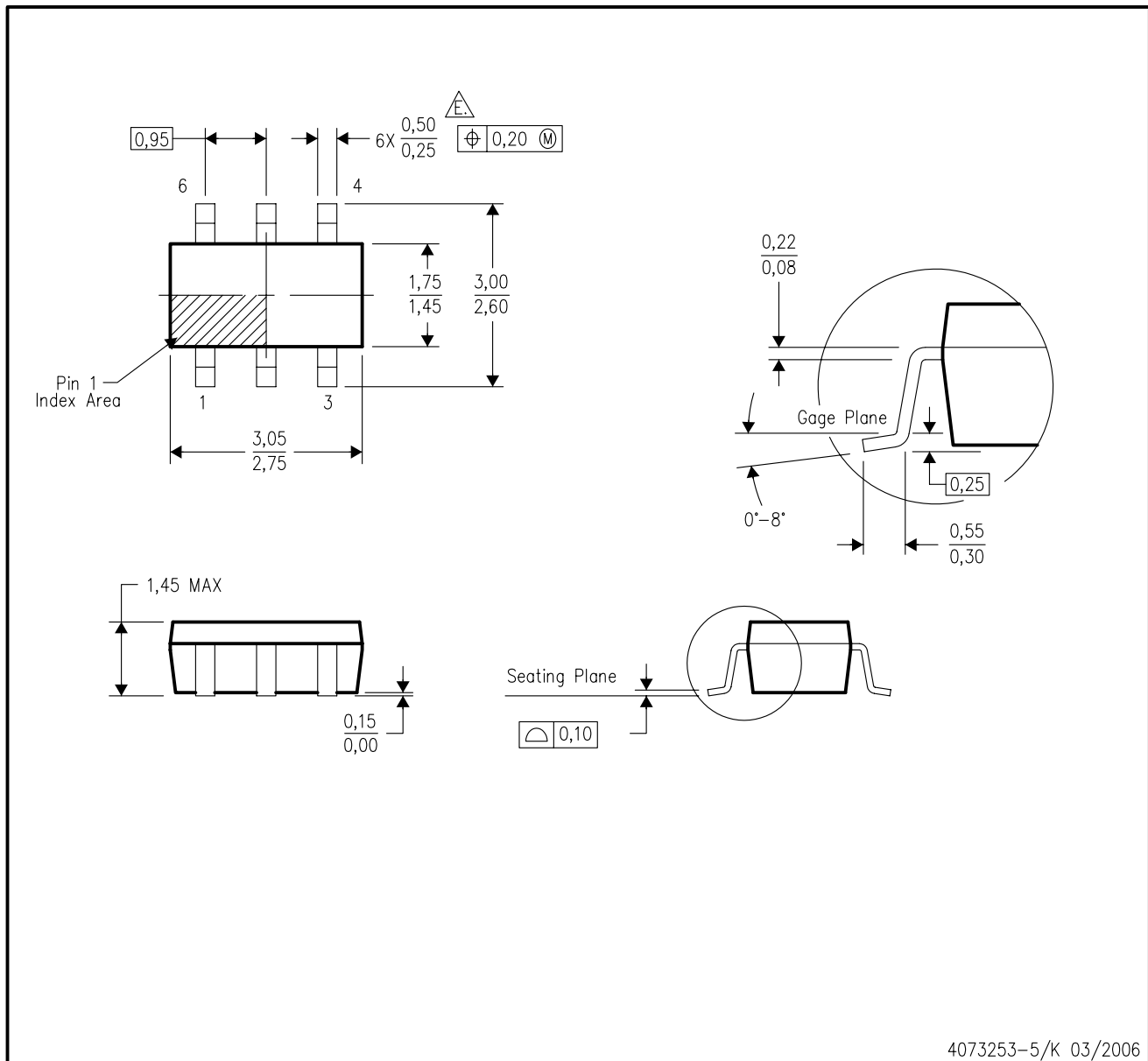

- NOTES:
- All linear dimensions are in millimeters.
  - This drawing is subject to change without notice.
  - Body dimensions do not include mold flash or protrusion. Mold flash and protrusion shall not exceed 0.15 per side.
  - Leads 1,2,3 may be wider than leads 4,5,6 for package orientation.
- Falls within JEDEC MO-178 Variation AB, except minimum lead width.

## DGK (S-PDSO-G8)

## PLASTIC SMALL-OUTLINE PACKAGE

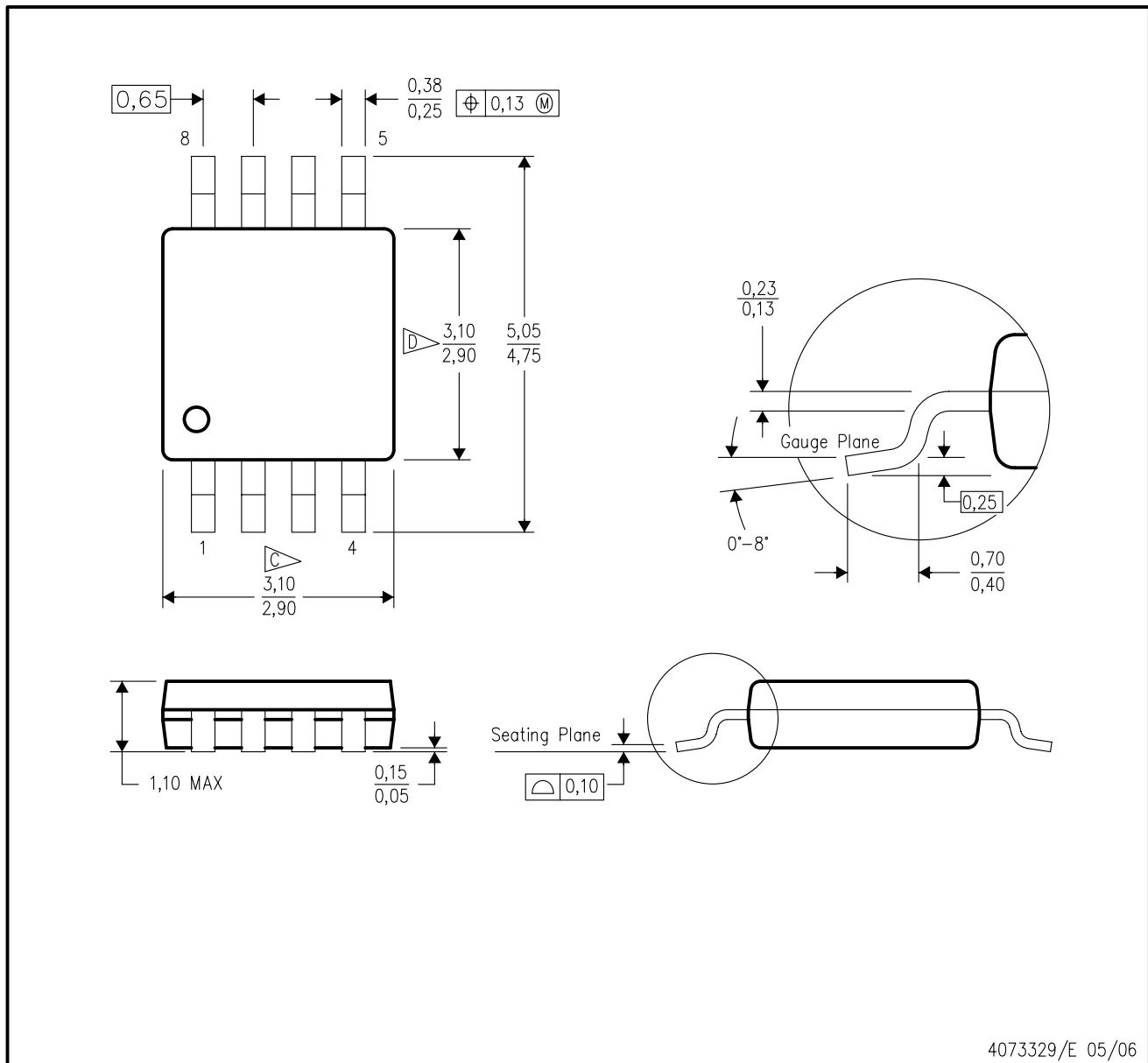

- NOTES:
- All linear dimensions are in millimeters.
  - This drawing is subject to change without notice.
  - Body length does not include mold flash, protrusions, or gate burrs. Mold flash, protrusions, or gate burrs shall not exceed 0.15 per end.
  - Body width does not include interlead flash. Interlead flash shall not exceed 0.50 per side.
  - Falls within JEDEC MO-187 variation AA, except interlead flash.

## DGS (S-PDSO-G10)

## PLASTIC SMALL-OUTLINE PACKAGE

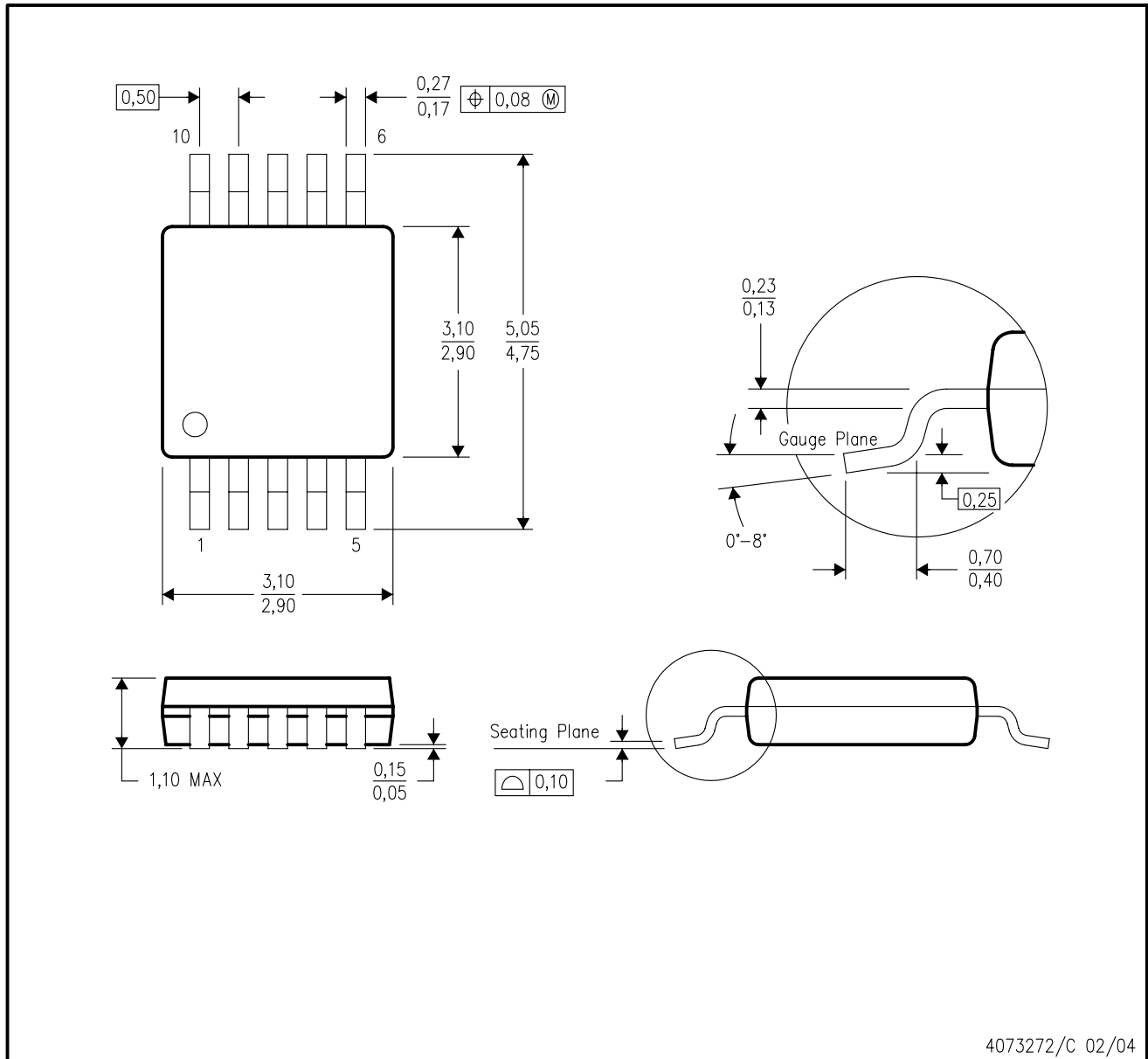

- NOTES:
- All linear dimensions are in millimeters.
  - This drawing is subject to change without notice.
  - Body dimensions do not include mold flash or protrusion.
  - Falls within JEDEC MO-187 variation BA.

D (R-PDSO-G8)

PLASTIC SMALL-OUTLINE PACKAGE

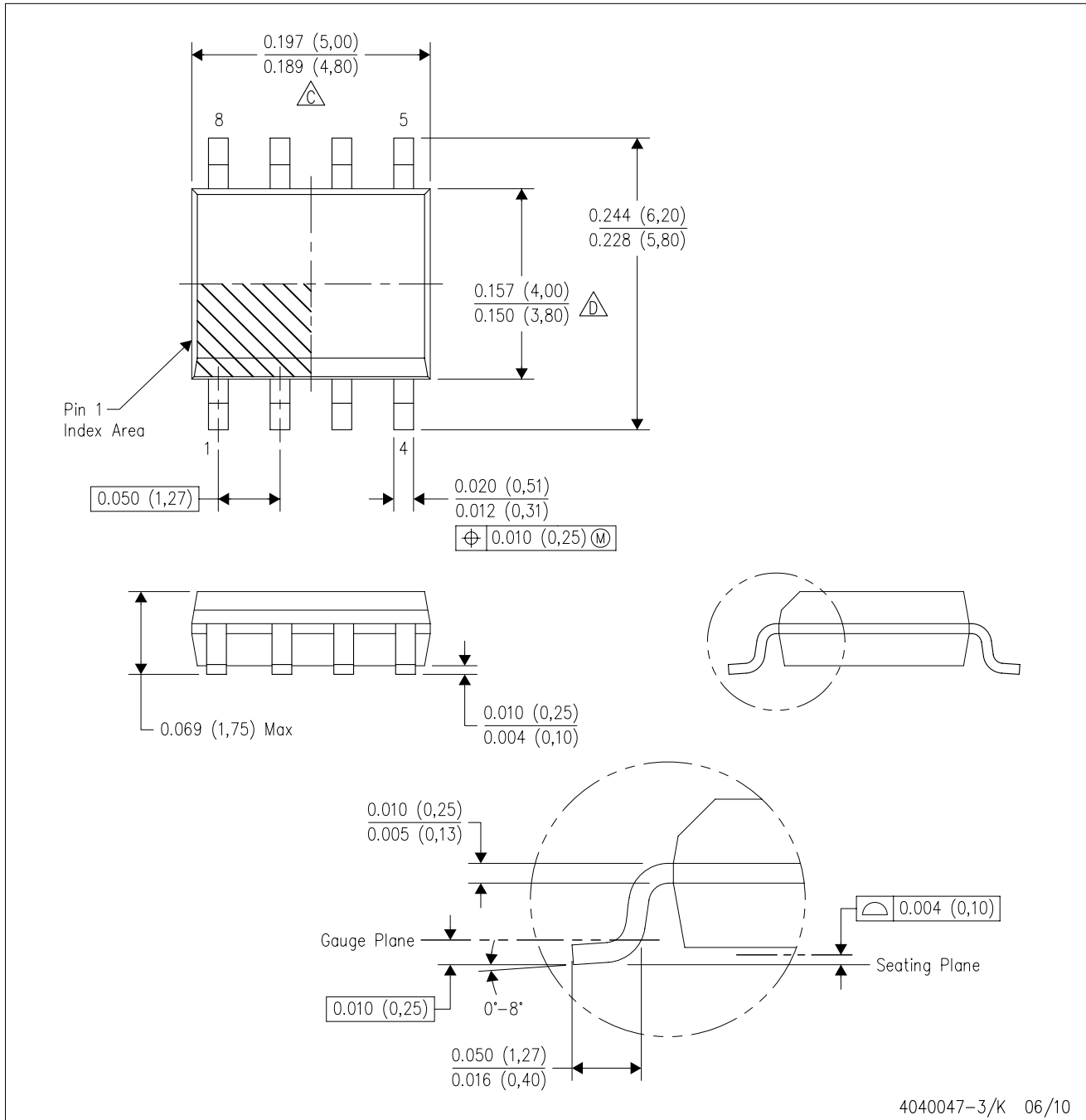

- NOTES:
- A. All linear dimensions are in inches (millimeters).
  - B. This drawing is subject to change without notice.
  - Body length does not include mold flash, protrusions, or gate burrs. Mold flash, protrusions, or gate burrs shall not exceed .006 (0,15) per end.
  - Body width does not include interlead flash. Interlead flash shall not exceed .017 (0,43) per side.
  - E. Reference JEDEC MS-012 variation AA.

D (R-PDSO-G8)

PLASTIC SMALL OUTLINE

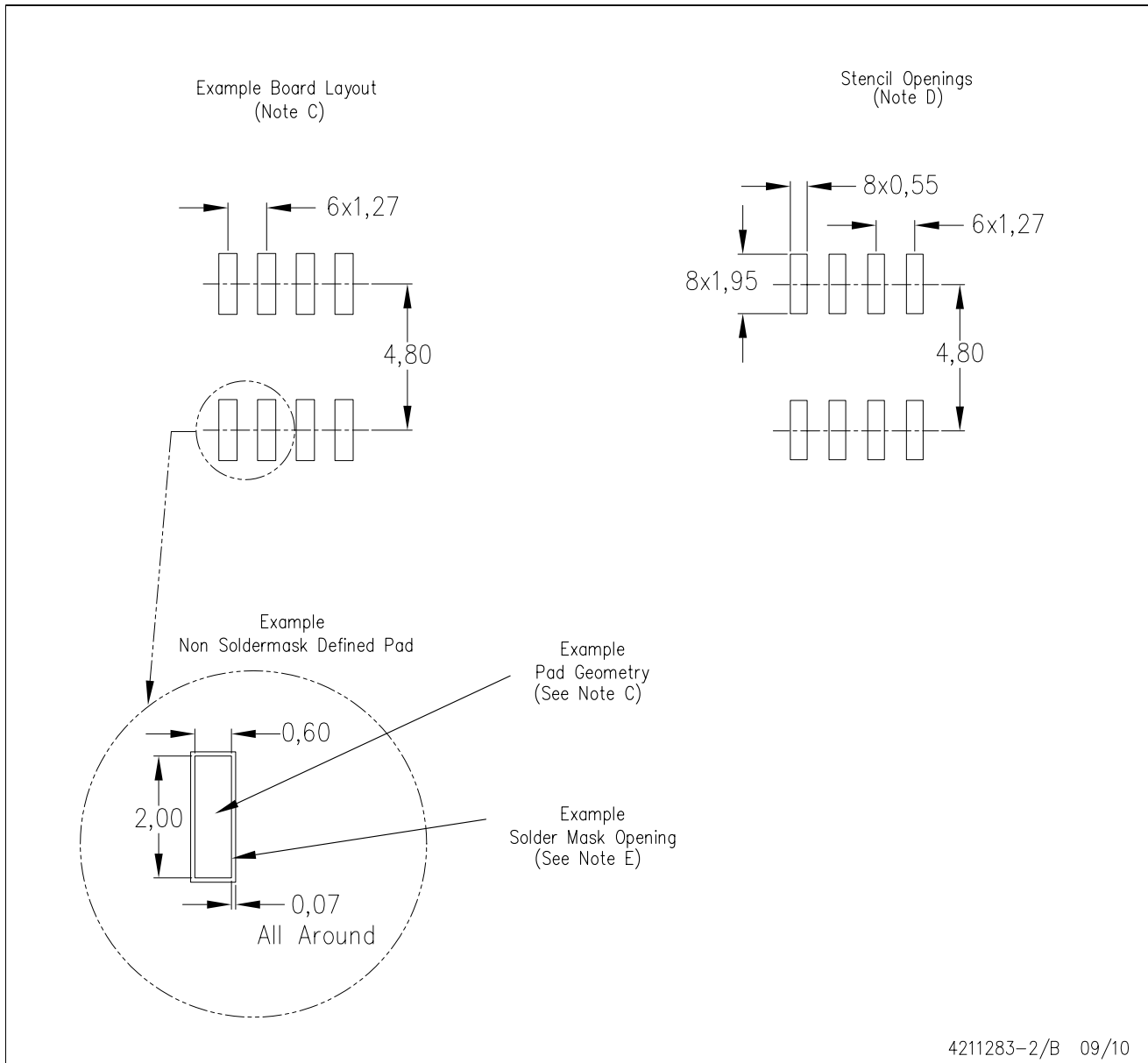

- NOTES:
- All linear dimensions are in millimeters.
  - This drawing is subject to change without notice.
  - Publication IPC-7351 is recommended for alternate designs.
  - Laser cutting apertures with trapezoidal walls and also rounding corners will offer better paste release. Customers should contact their board assembly site for stencil design recommendations. Refer to IPC-7525 for other stencil recommendations.
  - Customers should contact their board fabrication site for solder mask tolerances between and around signal pads.

## IMPORTANT NOTICE

Texas Instruments Incorporated and its subsidiaries (TI) reserve the right to make corrections, modifications, enhancements, improvements, and other changes to its products and services at any time and to discontinue any product or service without notice. Customers should obtain the latest relevant information before placing orders and should verify that such information is current and complete. All products are sold subject to TI's terms and conditions of sale supplied at the time of order acknowledgment.

TI warrants performance of its hardware products to the specifications applicable at the time of sale in accordance with TI's standard warranty. Testing and other quality control techniques are used to the extent TI deems necessary to support this warranty. Except where mandated by government requirements, testing of all parameters of each product is not necessarily performed.

TI assumes no liability for applications assistance or customer product design. Customers are responsible for their products and applications using TI components. To minimize the risks associated with customer products and applications, customers should provide adequate design and operating safeguards.

TI does not warrant or represent that any license, either express or implied, is granted under any TI patent right, copyright, mask work right, or other TI intellectual property right relating to any combination, machine, or process in which TI products or services are used. Information published by TI regarding third-party products or services does not constitute a license from TI to use such products or services or a warranty or endorsement thereof. Use of such information may require a license from a third party under the patents or other intellectual property of the third party, or a license from TI under the patents or other intellectual property of TI.

Reproduction of TI information in TI data books or data sheets is permissible only if reproduction is without alteration and is accompanied by all associated warranties, conditions, limitations, and notices. Reproduction of this information with alteration is an unfair and deceptive business practice. TI is not responsible or liable for such altered documentation. Information of third parties may be subject to additional restrictions.

Resale of TI products or services with statements different from or beyond the parameters stated by TI for that product or service voids all express and any implied warranties for the associated TI product or service and is an unfair and deceptive business practice. TI is not responsible or liable for any such statements.

TI products are not authorized for use in safety-critical applications (such as life support) where a failure of the TI product would reasonably be expected to cause severe personal injury or death, unless officers of the parties have executed an agreement specifically governing such use. Buyers represent that they have all necessary expertise in the safety and regulatory ramifications of their applications, and acknowledge and agree that they are solely responsible for all legal, regulatory and safety-related requirements concerning their products and any use of TI products in such safety-critical applications, notwithstanding any applications-related information or support that may be provided by TI. Further, Buyers must fully indemnify TI and its representatives against any damages arising out of the use of TI products in such safety-critical applications.

TI products are neither designed nor intended for use in military/aerospace applications or environments unless the TI products are specifically designated by TI as military-grade or "enhanced plastic." Only products designated by TI as military-grade meet military specifications. Buyers acknowledge and agree that any such use of TI products which TI has not designated as military-grade is solely at the Buyer's risk, and that they are solely responsible for compliance with all legal and regulatory requirements in connection with such use.

TI products are neither designed nor intended for use in automotive applications or environments unless the specific TI products are designated by TI as compliant with ISO/TS 16949 requirements. Buyers acknowledge and agree that, if they use any non-designated products in automotive applications, TI will not be responsible for any failure to meet such requirements.

Following are URLs where you can obtain information on other Texas Instruments products and application solutions:

<b>Products</b>		<b>Applications</b>	
Amplifiers	<a href="http://amplifier.ti.com">amplifier.ti.com</a>	Audio	<a href="http://www.ti.com/audio">www.ti.com/audio</a>
Data Converters	<a href="http://dataconverter.ti.com">dataconverter.ti.com</a>	Automotive	<a href="http://www.ti.com/automotive">www.ti.com/automotive</a>
DLP® Products	<a href="http://www.dlp.com">www.dlp.com</a>	Communications and Telecom	<a href="http://www.ti.com/communications">www.ti.com/communications</a>
DSP	<a href="http://dsp.ti.com">dsp.ti.com</a>	Computers and Peripherals	<a href="http://www.ti.com/computers">www.ti.com/computers</a>
Clocks and Timers	<a href="http://www.ti.com/clocks">www.ti.com/clocks</a>	Consumer Electronics	<a href="http://www.ti.com/consumer-apps">www.ti.com/consumer-apps</a>
Interface	<a href="http://interface.ti.com">interface.ti.com</a>	Energy	<a href="http://www.ti.com/energy">www.ti.com/energy</a>
Logic	<a href="http://logic.ti.com">logic.ti.com</a>	Industrial	<a href="http://www.ti.com/industrial">www.ti.com/industrial</a>
Power Mgmt	<a href="http://power.ti.com">power.ti.com</a>	Medical	<a href="http://www.ti.com/medical">www.ti.com/medical</a>
Microcontrollers	<a href="http://microcontroller.ti.com">microcontroller.ti.com</a>	Security	<a href="http://www.ti.com/security">www.ti.com/security</a>
RFID	<a href="http://www.ti-rfid.com">www.ti-rfid.com</a>	Space, Avionics & Defense	<a href="http://www.ti.com/space-avionics-defense">www.ti.com/space-avionics-defense</a>
RF/IF and ZigBee® Solutions	<a href="http://www.ti.com/lprf">www.ti.com/lprf</a>	Video and Imaging	<a href="http://www.ti.com/video">www.ti.com/video</a>
		Wireless	<a href="http://www.ti.com/wireless-apps">www.ti.com/wireless-apps</a>