

Integrated Silicon Pressure Sensor On-Chip Signal Conditioned, Temperature Compensated, and Calibrated

The MPXV4115V series piezoresistive transducer is a state-of-the-art monolithic silicon pressure sensor designed for a wide range of applications, particularly those employing a microcontroller with A/D inputs. This transducer combines advanced micromachining techniques, thin-film metallization and bipolar processing to provide an accurate, high-level analog output signal that is proportional to the applied pressure/vacuum. The small form factor and high reliability of on-chip integration make the sensor a logical and economical choice for the automotive system designer. [Figure 1](#) shows a block diagram of the internal circuitry integrated on a pressure sensor chip.

Features

- 1.5% Maximum error over 0° to 85°C
- Temperature Compensated from -40° + 125°C
- Ideally Suited for Microprocessor or Microcontroller-Based Systems
- Durable Thermoplastic (PPS) Surface Mount Package

Typical Applications

- Vacuum Pump Monitoring
- Brake Booster Monitoring

The MPXV4115V series pressure sensors are available in the basic element package or with a pressure port. Two packing options are also offered.

ORDERING INFORMATION				
Device Type	Case No.	MPX Series Order No.	Packing Options	Device Marking
SMALL OUTLINE PACKAGE (MPXV4115V SERIES)				
Basic Elements	482	MPXV4115V6U	Rails	MPXV4115V
	482	MPXV4115V6T1	Tape & Reel	MPXV4115V
Ported Elements	482A	MPXV4115VC6U	Rails	MPXV4115V

MPXV4115V SERIES

INTEGRATED
PRESSURE SENSOR
-115 to 0 kPa (-16.7 to 2.2 psi)
0.2 to 4.6 V OUTPUT

SMALL OUTLINE PACKAGE

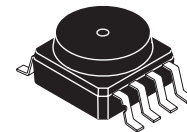

MPXV4115V6U/6T1
CASE 482-01

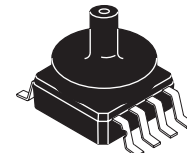

MPXV4115VC6U
CASE 482A-01

PIN NUMBER⁽¹⁾

1	N/C	5	N/C
2	V _S	6	N/C
3	GND	7	N/C
4	V _{OUT}	8	N/C

1. Pins 1, 5, 6, 7, and 8 are internal device connections. Do not connect to external circuitry or ground. Pin 1 is noted by the notch in the lead.

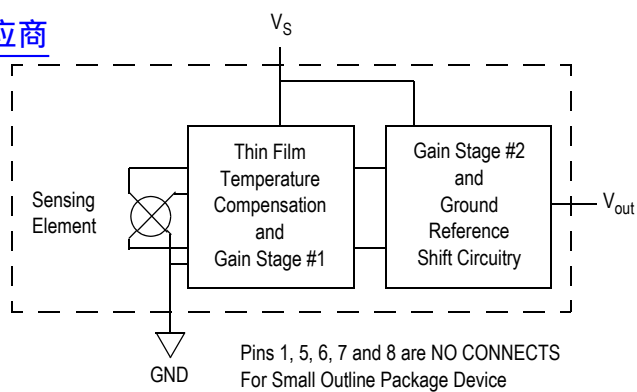

Figure 1. Fully Integrated Pressure Sensor Schematic

Table 1. Maximum Ratings⁽¹⁾

Rating	Symbol	Value	Unit
Maximum Pressure	P_{max}	400	kPa
Storage Temperature	T_{stg}	-40 to +125	°C
Operating Temperature	T_A	-40 to +125	°C

1. Exposure beyond the specified limits may cause permanent damage or degradation to the device.

Table 2. Operating Characteristics ($V_S = 5 \text{ Vdc}$, $T_A = 25^\circ\text{C}$ unless otherwise noted. Decoupling circuit shown in Figure 3 required to meet electrical specifications.)

Characteristic	Symbol	Min	Typ	Max	Unit
Pressure Range (Differential mode, Vacuum on metal cap side, Atmospheric pressure on back side)	P_{OP}	-115	—	0	kPa
Supply Voltage ⁽¹⁾	V_S	4.75	5.0	5.25	Vdc
Supply Current	I_o	—	6.0	10	mAdc
Full Scale Output ⁽²⁾ ($P_{diff} = 0 \text{ kPa}$) ²	V_{FSO}	4.535	4.6	4.665	Vdc
Full Scale Span ⁽³⁾ @ $V_S = 5.0 \text{ V}$	V_{FSS}	—	4.4	—	Vdc
Accuracy ⁽⁴⁾	—	—	—	1.5%	% V_{FSS}
Sensitivity	V/P	—	38.26	—	mV/kPa
Response Time ⁽⁵⁾	t_R	—	1.0	—	ms
Output Source Current at Full Scale Output	I_o	—	0.1	—	mAdc
Warm-Up Time ⁽⁶⁾	—	—	20	—	ms
Offset Stability ⁽⁷⁾	—	—	± 0.5	—	% V_{FSS}

1. Device is ratiometric within this specified excitation range.
2. Full Scale Output is defined as the output voltage at the maximum or full-rated pressure.
3. Full Scale Span is defined as the algebraic difference between the output voltage at full-rated pressure and the output voltage at the minimum-rated pressure.
4. Accuracy is the deviation in actual output from nominal output over the entire pressure range and temperature range as a percent of span at 25°C due to all sources of errors, including the following:
 - Linearity: Output deviation from a straight line relationship with pressure over the specified pressure range.
 - Temperature Hysteresis: Output deviation at any temperature within the operating temperature range, after the temperature is cycled to and from the minimum or maximum operating temperature points, with zero differential pressure applied.
 - Pressure Hysteresis: Output deviation at any pressure within the specified range, when this pressure is cycled to and from minimum or maximum rated pressure at 25°C .
 - TcSpan: Output deviation over the temperature range of 0° to 85°C , relative to 25°C .
 - TcOffset: Output deviation with minimum pressure applied, over the temperature range of 0° to 85°C , relative to 25°C .
5. Response Time is defined as the time for the incremental change in the output to go from 10% to 90% of its final value when subjected to a specified step change in pressure.
6. Warm-up Time is defined as the time required for the product to meet the specified output voltage after the Pressure has been stabilized.
7. Offset Stability is the product's output deviation when subjected to 1000 hours of Pulsed Pressure, Temperature Cycling with Bias Test.

ON-CHIP TEMPERATURE COMPENSATION, CALIBRATION, AND SIGNAL CONDITIONING

查询"MPXV4115VGT1"供应商

The performance over temperature is achieved by integrating the shear-stress strain gauge, temperature compensation, calibration and signal conditioning circuitry onto a single monolithic chip.

Figure 2 illustrates the gauge configuration in the basic chip carrier (Case 482). A fluorosilicone gel isolates the die surface and wire bonds from the environment, while allowing the pressure signal to be transmitted to the silicon diaphragm.

The MPXV4115V series sensor operating characteristics are based on use of dry air as pressure media. Media, other than dry air, may have adverse effects on sensor performance and long-term reliability. Internal reliability and qualification test for dry air, and other media, are available

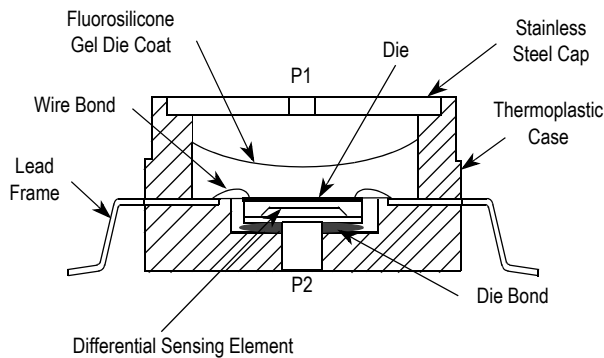

Figure 2. Cross-Sectional Diagram (not to scale)

from the factory. Contact the factory for information regarding media tolerance in your application.

Figure 3 shows the recommended decoupling circuit for interfacing the output of the integrated sensor to the A/D input of a microprocessor or microcontroller. Proper decoupling of the power supply is recommended.

Figure 4 shows the sensor output signal relative to differential pressure input. Typical, minimum and maximum output curves are shown for operation over a temperature range of 0°C to 85°C using the decoupling circuit shown in Figure 3. The output will saturate outside of the specified pressure range.

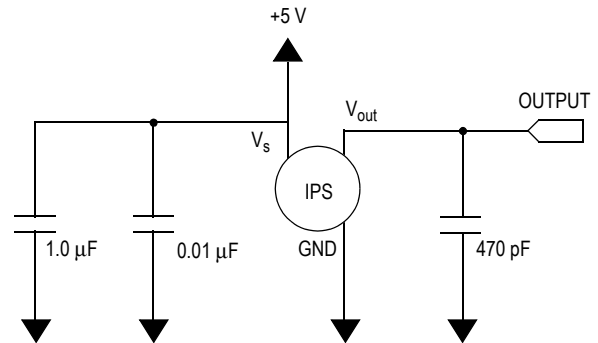

Figure 3. Recommended Power Supply Decoupling and Output Filtering
(For additional output filtering, please refer to Application Note AN1646.)

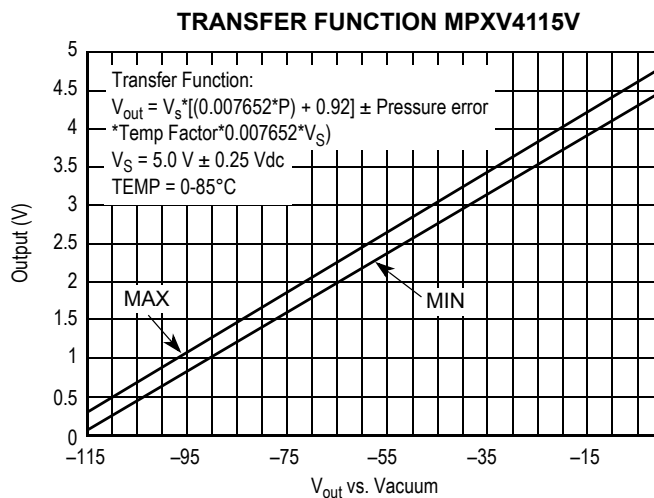

Figure 4. Applied Vacuum in kPa (below atmospheric pressure)

MINIMUM RECOMMENDED FOOTPRINT FOR SURFACE MOUNTED APPLICATIONS

[查询"MPXV4115V6T1"供应商](#)

Surface mount board layout is a critical portion of the total design. The footprint for the surface mount packages must be the correct size to ensure proper solder connection interface between the board and the package. With the correct

footprint, the packages will self align when subjected to a solder reflow process. It is always recommended to design boards with a solder mask layer to avoid bridging and shorting between solder pads.

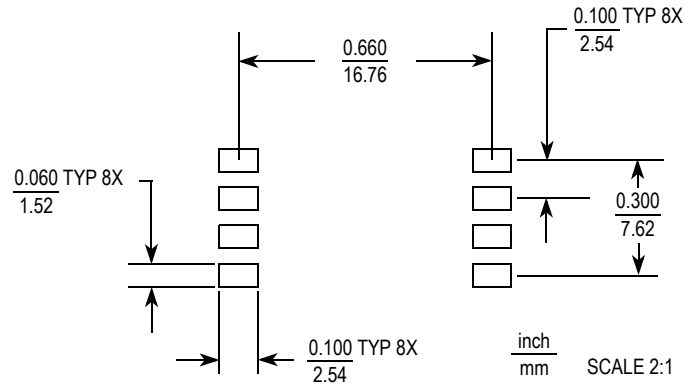
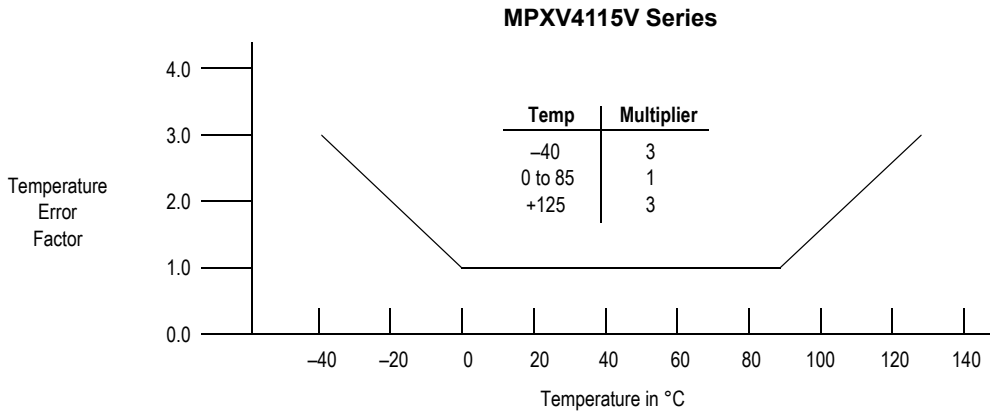

Figure 5. SOP Footprint (Case 482)

[查询"MPXV4115V01"供应商](#)

Nominal Transfer Value: $V_{out} = V_S (P \times 0.007652) + 0.92$
 $\pm (\text{Pressure Error} \times \text{Temp. Factor} \times 0.007652 \times V_S)$
 $V_S = 5 \text{ V} \pm 0.25 \text{ Vdc}$

Temperature Error Band



NOTE: The Temperature Multiplier is a linear response from 0°C to -40°C and from 85°C to 125°C.

Pressure Error Band

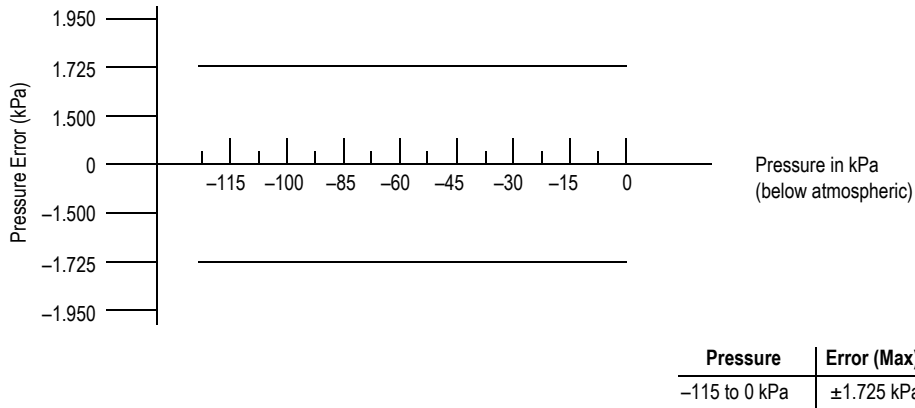

PACKAGE DIMENSIONS

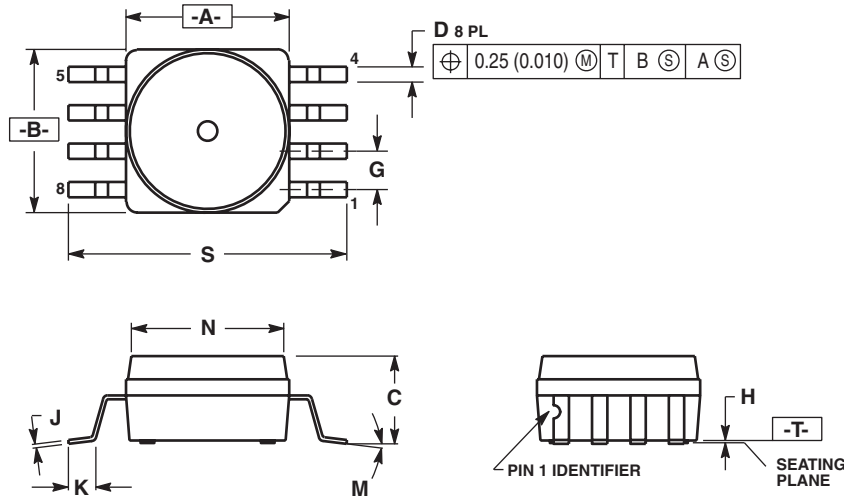

- NOTES:
1. DIMENSIONING AND TOLERANCING PER ANSI Y14.5M, 1982.
 2. CONTROLLING DIMENSION: INCH.
 3. DIMENSION A AND B DO NOT INCLUDE MOLD PROTRUSION.
 4. MAXIMUM MOLD PROTRUSION 0.15 (0.006).
 5. ALL VERTICAL SURFACES 5° TYPICAL DRAFT.

DIM	INCHES		MILLIMETERS	
	MIN	MAX	MIN	MAX
A	0.415	0.425	10.54	10.79
B	0.415	0.425	10.54	10.79
C	0.212	0.230	5.38	5.84
D	0.038	0.042	0.96	1.07
G	0.100 BSC		2.54 BSC	
H	0.002	0.010	0.05	0.25
J	0.009	0.011	0.23	0.28
K	0.061	0.071	1.55	1.80
M	0°	7°	0°	7°
N	0.405	0.415	10.29	10.54
S	0.709	0.725	18.01	18.41

CASE 482-01
 ISSUE O
 SMALL OUTLINE PACKAGE

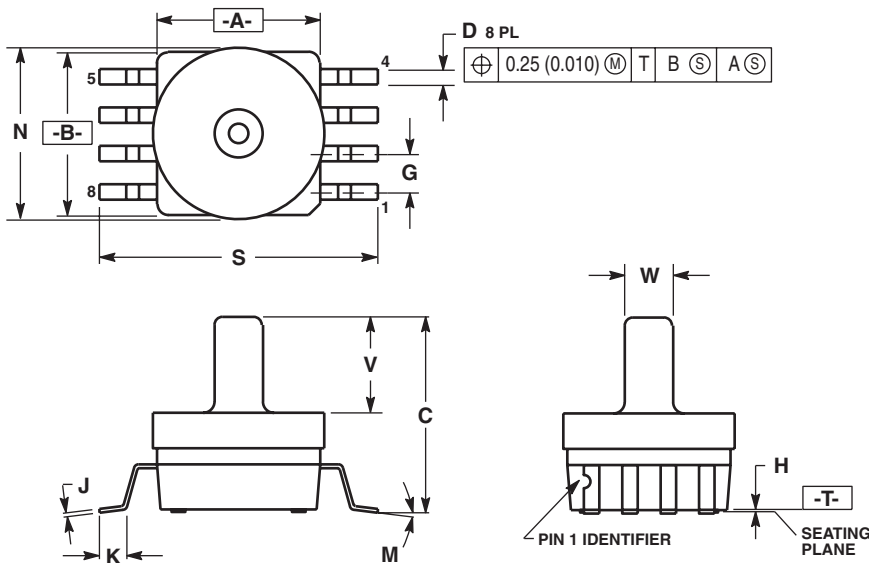

- NOTES:
1. DIMENSIONING AND TOLERANCING PER ANSI Y14.5M, 1982.
 2. CONTROLLING DIMENSION: INCH.
 3. DIMENSION A AND B DO NOT INCLUDE MOLD PROTRUSION.
 4. MAXIMUM MOLD PROTRUSION 0.15 (0.006).
 5. ALL VERTICAL SURFACES 5° TYPICAL DRAFT.

DIM	INCHES		MILLIMETERS	
	MIN	MAX	MIN	MAX
A	0.415	0.425	10.54	10.79
B	0.415	0.425	10.54	10.79
C	0.500	0.520	12.70	13.21
D	0.038	0.042	0.96	1.07
G	0.100 BSC		2.54 BSC	
H	0.002	0.010	0.05	0.25
J	0.009	0.011	0.23	0.28
K	0.061	0.071	1.55	1.80
M	0°	7°	0°	7°
N	0.444	0.448	11.28	11.38
S	0.709	0.725	18.01	18.41
V	0.245	0.255	6.22	6.48
W	0.115	0.125	2.92	3.17

CASE 482A-01
 ISSUE A
 SMALL OUTLINE PACKAGE

[查询"MPXV4115V6T1"供应商](#)

How to Reach Us:

Home Page:

www.freescale.com

E-mail:

support@freescale.com

USA/Europe or Locations Not Listed:

Freescale Semiconductor
Technical Information Center, CH370
1300 N. Alma School Road
Chandler, Arizona 85224
+1-800-521-6274 or +1-480-768-2130
support@freescale.com

Europe, Middle East, and Africa:

Freescale Halbleiter Deutschland GmbH
Technical Information Center
Schatzbogen 7
81829 Muenchen, Germany
+44 1296 380 456 (English)
+46 8 52200080 (English)
+49 89 92103 559 (German)
+33 1 69 35 48 48 (French)
support@freescale.com

Japan:

Freescale Semiconductor Japan Ltd.
Headquarters
ARCO Tower 15F
1-8-1, Shimo-Meguro, Meguro-ku,
Tokyo 153-0064
Japan
0120 191014 or +81 3 5437 9125
support.japan@freescale.com

Asia/Pacific:

Freescale Semiconductor Hong Kong Ltd.
Technical Information Center
2 Dai King Street
Tai Po Industrial Estate
Tai Po, N.T., Hong Kong
+800 2666 8080
support.asia@freescale.com

For Literature Requests Only:

Freescale Semiconductor Literature Distribution Center
P.O. Box 5405
Denver, Colorado 80217
1-800-441-2447 or 303-675-2140
Fax: 303-675-2150
LDCForFreescaleSemiconductor@hibbertgroup.com

Information in this document is provided solely to enable system and software implementers to use Freescale Semiconductor products. There are no express or implied copyright licenses granted hereunder to design or fabricate any integrated circuits or integrated circuits based on the information in this document.

Freescale Semiconductor reserves the right to make changes without further notice to any products herein. Freescale Semiconductor makes no warranty, representation or guarantee regarding the suitability of its products for any particular purpose, nor does Freescale Semiconductor assume any liability arising out of the application or use of any product or circuit, and specifically disclaims any and all liability, including without limitation consequential or incidental damages. "Typical" parameters that may be provided in Freescale Semiconductor data sheets and/or specifications can and do vary in different applications and actual performance may vary over time. All operating parameters, including "Typicals", must be validated for each customer application by customer's technical experts. Freescale Semiconductor does not convey any license under its patent rights nor the rights of others. Freescale Semiconductor products are not designed, intended, or authorized for use as components in systems intended for surgical implant into the body, or other applications intended to support or sustain life, or for any other application in which the failure of the Freescale Semiconductor product could create a situation where personal injury or death may occur. Should Buyer purchase or use Freescale Semiconductor products for any such unintended or unauthorized application, Buyer shall indemnify and hold Freescale Semiconductor and its officers, employees, subsidiaries, affiliates, and distributors harmless against all claims, costs, damages, and expenses, and reasonable attorney fees arising out of, directly or indirectly, any claim of personal injury or death associated with such unintended or unauthorized use, even if such claim alleges that Freescale Semiconductor was negligent regarding the design or manufacture of the part.

Freescale™ and the Freescale logo are trademarks of Freescale Semiconductor, Inc. All other product or service names are the property of their respective owners.

© Freescale Semiconductor, Inc. 2005. All rights reserved.

