

54F/74F174 Hex D Flip-Flop with Master Reset

General Description

The 'F174 is a high-speed hex D flip-flop. The device is used primarily as a 6-bit edge-triggered storage register. The information on the D inputs is transferred to storage during the LOW-to-HIGH clock transition. The device has a Master Reset to simultaneously clear all flip-flops.

Features

- Edge-triggered D-type inputs
- Buffered positive edge-triggered clock
- Asynchronous common reset
- Guaranteed 4000V minimum ESD protection

Ordering Code: See Section 11

Commercial	Military	Package Number	Package Description
74F174PC		N16E	16-Lead (0.300" Wide) Molded Dual-In-Line
	54F174DM (Note 2)	J16A	16-Lead Ceramic Dual-In-Line
74F174SC (Note 1)		M16A	16-Lead (0.150" Wide) Molded Small Outline, JEDEC
74F174SJ (Note 1)		M16D	16-Lead (0.300" Wide) Molded Small Outline, EIAJ
	54F174FM (Note 2)	W16A	16-Lead Cerpack
	54F174LM (Note 2)	E20A	20-Lead Ceramic Leadless Chip Carrier, Type C

Note 1: Devices also available in 13" reel. Use Suffix = SCX and SJX.

Note 2: Military grade device with environmental and burn-in processing. Use suffix = DMQB, FMQB and LMQB.

Logic Symbols

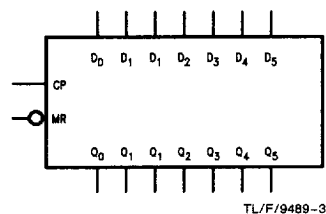

IEEE/IEC

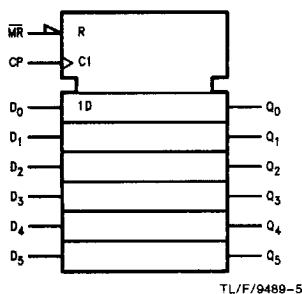

Connection Diagrams

Pin Assignment for DIP, SOIC and Flatpak

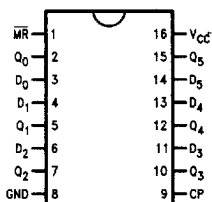

Pin Assignment for LCC

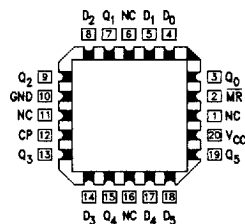

Unit Loading/Fan Out: See Section 2 for U.L. Definitions

Pin Names	Description	54F/74F	
		U.L. HIGH/LOW	Input I_{IH}/I_{IL} Output I_{OH}/I_{OL}
D ₀ -D ₅	Data Inputs	1.0/1.0	20 μ A/ -0.6 mA
CP	Clock Pulse Input (Active Rising Edge)	1.0/1.0	20 μ A/ -0.6 mA
MR	Master Reset Input (Active LOW)	1.0/1.0	20 μ A/ -0.6 mA
Q ₀ -Q ₅	Outputs	50/33.3	-1 mA/20 mA

Functional Description

The 'F174 consists of six edge-triggered D flip-flops with individual D inputs and Q outputs. The Clock (CP) and Master Reset (MR) are common to all flip-flops. Each D input's state is transferred to the corresponding flip-flop's output following the LOW-to-HIGH Clock (CP) transition. A LOW input to the Master Reset (MR) will force all outputs LOW independent of Clock or Data inputs. The 'F174 is useful for applications where the true output only is required and the Clock and Master Reset are common to all storage elements.

Truth Table

Inputs			Outputs
MR	CP	D _n	Q _n
L	X	X	L
H	\nearrow	H	H
H	\searrow	L	L

H = HIGH Voltage Level

L = LOW Voltage Level

X = Immaterial

\nearrow = LOW-to-HIGH Clock Transition

Logic Diagram

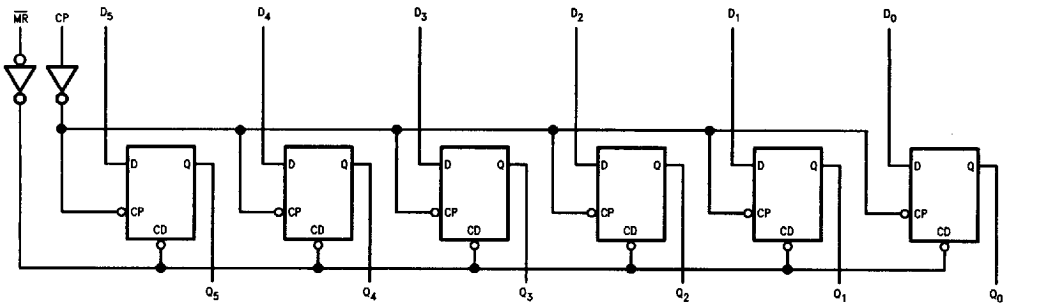

Please note that this diagram is provided only for the understanding of logic operations and should not be used to estimate propagation delays.

Absolute Maximum Ratings (Note 1)

If Military/Aerospace specified devices are required, please contact the National Semiconductor Sales Office/Distributors for availability and specifications.

Storage Temperature	-65°C to +150°C
Ambient Temperature under Bias	-55°C to +125°C
Junction Temperature under Bias	-55°C to +175°C
Plastic	-55°C to +150°C
V _{CC} Pin Potential to Ground Pin	-0.5V to +7.0V
Input Voltage (Note 2)	-0.5V to +7.0V
Input Current (Note 2)	-30 mA to +5.0 mA
Voltage Applied to Output in HIGH State (with V _{CC} = 0V)	
Standard Output	-0.5V to V _{CC}
TRI-STATE® Output	-0.5V to +5.5V
Current Applied to Output in LOW State (Max)	twice the rated I _{OL} (mA)
ESD Last Passing Voltage (Min)	4000V

Note 1: Absolute maximum ratings are values beyond which the device may be damaged or have its useful life impaired. Functional operation under these conditions is not implied.

Note 2: Either voltage limit or current limit is sufficient to protect inputs.

Recommended Operating Conditions

Free Air Ambient Temperature	
Military	-55°C to +125°C
Commercial	0°C to +70°C
Supply Voltage	
Military	+4.5V to +5.5V
Commercial	+4.5V to +5.5V

DC Electrical Characteristics

Symbol	Parameter	54F/74F			Units	V _{CC}	Conditions
		Min	Typ	Max			
V _{IH}	Input HIGH Voltage	2.0			V		Recognized as a HIGH Signal
V _{IL}	Input LOW Voltage				V		Recognized as a LOW Signal
V _{CD}	Input Clamp Diode Voltage				V	Min	I _{IN} = -18 mA
V _{OH}	Output HIGH Voltage	54F 10% V _{CC}	2.5		V	Min	I _{OH} = -1 mA
		74F 10% V _{CC}	2.5				I _{OH} = -1 mA
		74F 5% V _{CC}	2.7				I _{OH} = -1 mA
V _{OL}	Output LOW Voltage	54F 10% V _{CC}		0.5	V	Min	I _{OL} = 20 mA
		74F 10% V _{CC}		0.5			I _{OL} = 20 mA
I _{IH}	Input HIGH Current	54F		20.0	μA	Max	V _{IN} = 2.7V
		74F		5.0			
I _{BVI}	Input HIGH Current Breakdown Test	54F		100	μA	Max	V _{IN} = 7.0V
		74F		7.0			
I _{CEX}	Output HIGH Leakage Current	54F		250	μA	Max	V _{OUT} = V _{CC}
		74F		50			
V _{ID}	Input Leakage Test	74F	4.75		V	0.0	I _{ID} = 1.9 μA All Other Pins Grounded
I _{OD}	Output Leakage Circuit Current	74F		3.75	μA	0.0	V _{IOD} = 150 mV All Other Pins Grounded
I _{IL}	Input LOW Current				mA	Max	V _{IN} = 0.5V
I _{OS}	Output Short-Circuit Current				mA	Max	V _{OUT} = 0V
I _{CC}	Power Supply Current				mA	Max	CP =  D _n = MR = HIGH
I _{CCL}	Power Supply Current				mA	Max	V _O = LOW

AC Electrical Characteristics: See Section 2 for Waveforms and Load Configurations

[查询"54F174DMQB"供应商](#)

Symbol	Parameter	74F			54F		74F		Units	Fig. No.
		T _A = +25°C V _{CC} = +5.0V C _L = 50 pF			T _A , V _{CC} = Mil C _L = 50 pF		T _A , V _{CC} = Com C _L = 50 pF			
		Min	Typ	Max	Min	Max	Min	Max		
f _{max}	Maximum Clock Frequency	80			70		80		MHz	2-1
t _{PLH}	Propagation Delay CP to Q _n	3.5	5.5	8.0	3.0	10.0	3.5	9.0	ns	2-3
t _{PHL}	Propagation Delay M _R to Q _n	4.0	7.0	10.0	4.0	12.0	4.0	11.0		
t _{PHL}	Propagation Delay M _R to Q _n	5.0	10.0	14.0	5.0	16.0	5.0	15.0	ns	2-3

AC Operating Requirements: See Section 2 for Waveforms

Symbol	Parameter	74F		54F		74F		Units	Fig. No.
		T _A = +25°C V _{CC} = +5.0V		T _A , V _{CC} = Mil		T _A , V _{CC} = Com			
		Min	Max	Min	Max	Min	Max		
t _s (H)	Setup Time, HIGH or LOW D _n to CP	4.8		5.0		4.8		ns	2-6
t _s (L)		4.0		5.0		4.0			
t _h (H)	Hold Time, HIGH or LOW D _n to CP	0		2.0		0		ns	2-6
t _h (L)		0		2.0		0			
t _w (H)	CP Pulse Width	4.0		5.0		4.0		ns	2-4
t _w (L)	HIGH or LOW	6.0		7.5		6.0			
t _w (L)	M _R Pulse Width, LOW	5.0		6.5		5.0		ns	2-4
t _{rec}	Recovery Time, M _R to CP	5.0		6.0		5.0			2-6