

REVISIONS

LTR	DESCRIPTION	DATE (YR-MO-DA)	APPROVED
	查询"5962-9471301QXC"供应商		

REV																				
SHEET																				
REV																				
SHEET	15	16	17	18	19															

REV STATUS OF SHEETS	REV																			
	SHEET	1	2	3	4	5	6	7	8	9	10	11	12	13	14					
PMIC N/A	PREPARED BY Kenneth Rice	DEFENSE ELECTRONICS SUPPLY CENTER DAYTON, OHIO 45444																		
STANDARD MICROCIRCUIT DRAWING THIS DRAWING IS AVAILABLE FOR USE BY ALL DEPARTMENTS AND AGENCIES OF THE DEPARTMENT OF DEFENSE AMSC N/A	CHECKED BY Jeff Bowling																			
	APPROVED BY Michael A. Frye	MICROCIRCUIT, MEMORY, DIGITAL, CMOS ELECTRICALLY ALTERABLE FLASH PROGRAMMABLE LOGIC DEVICE, MONOLITHIC SILICON																		
	DRAWING APPROVAL DATE 96-03-14		SIZE A CAGE CODE 67268 5962-94713																	
	REVISION LEVEL	SHEET 1 OF 19																		

DESC FORM 193 JUL 94 DISTRIBUTION STATEMENT A. Approved for public release; distribution is unlimited. 5962-E276-96

9004708 0019940 44T

1. SCOPE

1.1 Scope. This drawing documents two product assurance class levels consisting of high reliability (device classes Q and M) and Space 47301 (X) (Device class V). A choice of case outlines and lead finishes are available and are reflected in the Part or Identifying Number (PIN). When available, a choice of Radiation Hardness Assurance (RHA) levels are reflected in the PIN.

1.2 PIN. The PIN is be as shown in the following example:

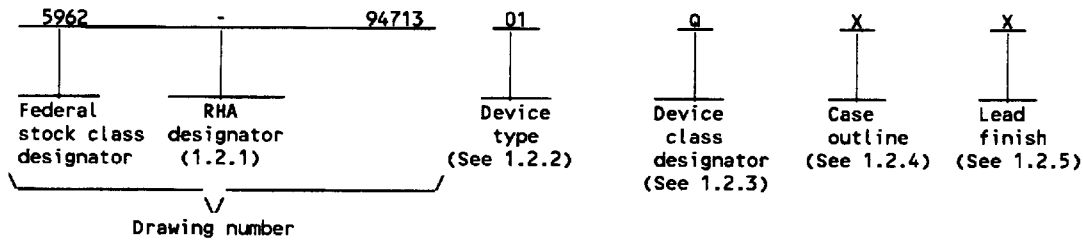

1.2.1 RHA designator. Device classes Q and V RHA marked devices meet the MIL-PRF-38535 specified RHA levels and are marked with the appropriate RHA designator. Device class M RHA marked devices meet the MIL-PRF-38535, appendix A specified RHA levels and are marked with the appropriate RHA designator. A dash (-) indicates a non-RHA device.

1.2.2 Device type(s). The device type(s) shall identify the circuit function as follows:

Device type	Generic number	Circuit function	Toggle Speed (Mhz)
01	7C374	128 Macrocell CPLD	66
02	7C374	128 Macrocell CPLD	83

1.2.3 Device class designator. The device class designator is a single letter identifying the product assurance level as follows:

Device class	Device requirements documentation
M	Vendor self-certification to the requirements for MIL-STD-883 compliant, non-JAN class level B microcircuits in accordance with MIL-PRF-38535, appendix A
Q or V	Certification and qualification to MIL-PRF-38535

1.2.4 Case outline(s). The case outline(s) are as designated in MIL-STD-1835 and as follows:

Outline letter	Descriptive designator	Terminals	Package style
X	CMGA15-P84C	84	Pin grid array
Y	GQCC1-J84	84	J leaded chip carrier

1.2.5 Lead finish. The lead finish is as specified in MIL-PRF-38535 for device classes Q and V or MIL-PRF-38535, appendix A for device class M.

1.3 Absolute maximum ratings. 1/

Supply voltage range (V_{CC})	-2.0 V dc to +7.0 V dc
Programming supply voltage range (V_{PP})	-2.0 V dc to +13.5 V dc 2/
DC input voltage range	-2.0 V dc to +7.0 V dc 2/
Maximum power dissipation	2.5 W 3/
Lead temperature (soldering, 10 seconds)	+260°C
Thermal resistance, junction-to-case (θ_{JC}):	
Case outline X and Y	See MIL-STD-1835
Junction temperature (T_J)	+175°C 4/
Storage temperature range	-65°C to +150°C
Endurance	25 erase/write cycles (minimum)
Data retention	10 years (minimum)

- 1/ Stresses above the absolute maximum rating may cause permanent damage to the device. Extended operation at the maximum levels may degrade performance and affect reliability.
- 2/ Minimum dc input voltage is -0.5 V, which may overshoot to -2.0 V for periods less than 20 ns. Maximum dc voltage on output pins is $V_{CC} + 0.5$ V, which may overshoot to +7.0 V for periods less than 20 ns under load conditions.
- 3/ Must withstand the added P_D due to short circuit test (e.g., IOS).
- 4/ Maximum junction temperature shall not be exceeded except for allowable short duration burn-in screening conditions in accordance with method 5004 of MIL-STD-883.

STANDARD MICROCIRCUIT DRAWING DEFENSE ELECTRONICS SUPPLY CENTER DAYTON, OHIO 45444	SIZE A		5962-94713
		REVISION LEVEL	SHEET 2

1.4 Recommended operating conditions. 5/

Case operating temperature Range (T_c)	-55°C to +125°C
Supply voltage relative to ground (V _{CC})	+4.5 V dc minimum to +5.5 V dc maximum
Ground voltage (GND)	0 V dc
Input high voltage (V _{IH})	2.2 V dc minimum
Input low voltage (V _{IL})	0.8 V dc maximum
Input rise time (t _R)	100 ns maximum
Input fall time (t _F)	100 ns maximum

1.5 Digital logic testing for device classes Q and V.

Fault coverage measurement of manufacturing logic tests (MIL-STD-883, test method 5012) - - - - - 6/ percent

2. APPLICABLE DOCUMENTS

2.1 Government specification, standards, and handbooks. The following specification, standards, and handbooks form a part of this drawing to the extent specified herein. Unless otherwise specified, the issues of these documents are those listed in the issue of the Department of Defense Index of Specifications and Standards (DoDISS) and supplement thereto, cited in the solicitation.

SPECIFICATION

MILITARY

MIL-PRF-38535 - Integrated Circuits, Manufacturing, General Specification for.

STANDARDS

MILITARY

MIL-STD-883 - Test Methods and Procedures for Microelectronics.
 MIL-STD-973 - Configuration Management.
 MIL-STD-1835 - Microcircuit Case Outlines.

HANDBOOKS

MILITARY

MIL-HDBK-103 - List of Standard Microcircuit Drawings (SMD's).
 MIL-HDBK-780 - Standard Microcircuit Drawings.

(Unless otherwise indicated, copies of the specification, standards, and handbooks are available from the Standardization Document Order Desk, 700 Robbins Avenue, Building 4D, Philadelphia, PA 19111-5094.)

2.2 Non-Government publications. The following documents form a part of this document to the extent specified herein. Unless otherwise specified, the issues of the documents which are DoD adopted are those listed in the issue of the DoDISS cited in the solicitation. Unless otherwise specified, the issues of documents not listed in the DoDISS are the issues of the documents cited in the solicitation.

AMERICAN SOCIETY FOR TESTING AND MATERIALS (ASTM)

ASTM Standard F1192-88 - Standard Guide for the Measurement of Single Event Phenomena from Heavy Ion Irradiation of Semiconductor Devices.

(Applications for copies of ASTM publications should be addressed to the American Society for Testing and Materials, 1916 Race Street, Philadelphia, PA 19103.)

ELECTRONICS INDUSTRIES ASSOCIATION (EIA)

JEDEC Standard No. 17 - A Standardized Test Procedure for the Characterization of Latch-up in CMOS Integrated Circuits.

(Applications for copies should be addressed to the Electronics Industries Association, 2500 Wilson Blvd., Arlington, VA 22201.)

(Non-Government standards and other publications are normally available from the organizations that prepare or distribute the documents. These documents also may be available in or through libraries or other informational services.)

5/ All voltage values in this drawing are with respect to V_{SS}.
 6/ Values will be added when they become available.

STANDARD MICROCIRCUIT DRAWING DEFENSE ELECTRONICS SUPPLY CENTER DAYTON, OHIO 45444	SIZE A		5962-94713
		REVISION LEVEL	SHEET 3

2.3 Order of precedence. In the event of a conflict between the text of this drawing and the references cited herein, the text of this drawing takes precedence. Nothing in this document, however, supersedes applicable laws and regulations unless a specific exemption has been obtained.

3. REQUIREMENTS

3.1 Item requirements. The individual item requirements for device classes Q and V shall be in accordance with MIL-PRF-38535 and as specified herein or as modified in the device manufacturer's Quality Management (QM) plan. The modification in the QM plan shall not affect the form, fit, or function as described herein. The individual item requirements for device class M shall be in accordance with MIL-PRF-38535, appendix A for non-JAN class level B devices and as specified herein.

3.2 Design, construction, and physical dimensions. The design, construction, and physical dimensions shall be as specified in MIL-PRF-38535 and herein for device classes Q and V or MIL-PRF-38535, appendix A and herein for device class M.

3.2.1 Case outline(s). The case outline(s) shall be in accordance with 1.2.4 herein.

3.2.2 Terminal connections. The terminal connections shall be as specified on and figure 1.

3.2.3 Truth table. The truth table shall be as specified in figure 2.

3.3 Electrical performance characteristics and postirradiation parameter limits. Unless otherwise specified herein, the electrical performance characteristics and postirradiation parameter limits are as specified in table I and shall apply over the full case operating temperature range.

3.4 Electrical test requirements. The electrical test requirements shall be the subgroups specified in table IIA. The electrical tests for each subgroup are defined in table I.

3.5 Marking. The part shall be marked with the PIN listed in 1.2 herein. In addition, the manufacturer's PIN may also be marked as listed in MIL-HDBK-103. For packages where marking of the entire SMD PIN number is not feasible due to space limitations, the manufacturer has the option of not marking the "5962-" on the device. For RHA product using this option, the RHA designator shall still be marked. Marking for device classes Q and V shall be in accordance with MIL-PRF-38535. Marking for device class M shall be in accordance with MIL-PRF-38535, appendix A.

3.5.1 Certification/compliance mark. The certification mark for device classes Q and V shall be a "QML" or "Q" as required in MIL-PRF-38535. The compliance mark for device class M shall be a "C" as required in MIL-PRF-38535, appendix A.

3.6 Certificate of compliance. For device classes Q and V, a certificate of compliance shall be required from a QML-38535 listed manufacturer in order to supply to the requirements of this drawing (see 6.6.1 herein). For device class M, a certificate of compliance shall be required from a manufacturer in order to be listed as an approved source of supply in MIL-HDBK-103 (see 6.6.2 herein). The certificate of compliance submitted to DESC-EC prior to listing as an approved source of supply for this drawing shall affirm that the manufacturer's product meets, for device classes Q and V, the requirements of MIL-PRF-38535 and herein or for device class M, the requirements of MIL-PRF-38535, appendix A and herein.

3.7 Certificate of conformance. A certificate of conformance as required for device classes Q and V in MIL-PRF-38535 or for device class M in MIL-PRF-38535, appendix A shall be provided with each lot of microcircuits delivered to this drawing.

3.8 Notification of change for device class M. For device class M, notification to DESC-EC of change of product (see 6.2 herein) involving devices acquired to this drawing is required for any change as defined in MIL-STD-973.

3.9 Verification and review for device class M. For device class M, DESC, DESC's agent, and the acquiring activity retain the option to review the manufacturer's facility and applicable required documentation. Offshore documentation shall be made available onshore at the option of the reviewer.

3.10 Microcircuit group assignment for device class M. Device class M devices covered by this drawing shall be in microcircuit group number 42 (see MIL-PRF-38535, appendix A).

3.11 Processing CPLDs. All testing requirements and quality assurance provisions herein shall be satisfied by the manufacturer prior to delivery.

3.11.1 Erasure of CPLDs. When specified, devices shall be erased in accordance with the procedures and characteristics specified in 4.6 herein.

3.11.2 Programmability of CPLDs. When specified, devices shall be programmed to the specified pattern using the procedures and characteristics specified in 4.7 herein.

STANDARD MICROCIRCUIT DRAWING DEFENSE ELECTRONICS SUPPLY CENTER DAYTON, OHIO 45444	SIZE A		5962-94713
		REVISION LEVEL	SHEET 4

DESC FORM 193A
JUL 94

9004708 0019943 159

3.11.3 Verification of erasure or programmed CPLDs. When specified, devices shall be verified as either programmed (see 4.7 herein) to the specified pattern or erased (see 4.6 herein). As a minimum, verification shall consist of performing a functional test (subgroup 7) to verify that all bits are in the proper state. Any bit that does not verify to be in the proper state shall constitute a device failure, and shall be removed from the lot.

查询 5962-94713 QXC 供应商

3.12 Endurance. A reprogrammability test shall be completed as part of the vendor's reliability monitor. This reprogrammability test shall be done only for initial characterization and after any design or process changes which may affect the reprogrammability of the device. The methods and procedures may be vendor specific, but shall be under document control and shall be made available upon request.

3.13 Data Retention. A data retention stress test shall be completed as part of the vendor's reliability monitors. This test shall be done for initial characterization and after any design or process changes which may affect data retention. The methods and procedures may be vendor specific, but shall guarantee the number of years listed in section 1.3 herein over the full military temperature range. The vendor's procedure shall be kept under document control and shall be made available upon request of the acquiring or preparing activity, along with the test data.

4. QUALITY ASSURANCE PROVISIONS

4.1 Sampling and inspection. For device classes Q and V, sampling and inspection procedures shall be in accordance with MIL-PRF-38535 or as modified in the device manufacturer's Quality Management (QM) plan. The modification in the QM plan shall not affect the form, fit, or function as described herein. For device class M, sampling and inspection procedures shall be in accordance with MIL-PRF-38535, appendix A.

4.2 Screening. For device classes Q and V, screening shall be in accordance with MIL-PRF-38535, and shall be conducted on all devices prior to qualification and technology conformance inspection. For device class M, screening shall be in accordance with method 5004 of MIL-STD-883, and shall be conducted on all devices prior to quality conformance inspection.

4.2.1 Additional criteria for device class M.

- a. Delete the sequence specified as initial (pre-burn-in) electrical parameters through interim (post-burn-in) electrical parameters of method 5004 and substitute lines 1 through 6 of table IIA herein.
- b. Prior to burn-in, the devices shall be programmed (see 4.7 herein) with a checkerboard pattern or equivalent (manufacturers at their option may employ an equivalent pattern provided it is topologically true alternating bit pattern). The pattern shall be read before and after burn-in. Devices having bits not in the proper state after burn-in shall constitute a device failure and shall be removed from the lot. The manufacturer as an option may use built-in test circuitry by testing the entire lot to verify programmability and AC performance without programming the user array.
- c. For device class M, the test circuit shall be maintained by the manufacturer under document revision level control and shall be made available to the preparing or acquiring activity upon request. For device class M the test circuit shall specify the inputs, outputs, biases, and power dissipation, as applicable, in accordance with the intent specified in test method 1015.
- d. Interim and final electrical test parameters shall be as specified in table IIA herein.

4.2.2 Additional criteria for device classes Q and V.

- a. The burn-in test duration, test condition and test temperature, or approved alternatives shall be as specified in the device manufacturer's QM plan in accordance with MIL-PRF-38535. The burn-in test circuit shall be maintained under document revision level control of the device manufacturer's Technology Review Board (TRB) in accordance with MIL-PRF-38535 and shall be made available to the acquiring or preparing activity upon request. The test circuit shall specify the inputs, outputs, biases, and power dissipation, as applicable, in accordance with the intent specified in test method 1015 of MIL-STD-883.
- b. Interim and final electrical test parameters shall be as specified in table IIA herein.
- c. Additional screening for device class V beyond the requirements of device class Q shall be as specified in MIL-PRF-38535, appendix B.

4.3 Qualification inspection for device classes Q and V. Qualification inspection for device classes Q and V shall be in accordance with MIL-PRF-38535. Inspections to be performed shall be those specified in MIL-PRF-38535 and herein for groups A, B, C, D, and E inspections (see 4.4.1 through 4.4.4).

STANDARD MICROCIRCUIT DRAWING DEFENSE ELECTRONICS SUPPLY CENTER DAYTON, OHIO 45444	SIZE A		5962-94713
		REVISION LEVEL	SHEET 5

TABLE I. Electrical performance characteristics.

Test Symbol	Conditions 4.5 V ≤ V _{CC} ≤ 5.5 V -55°C ≤ T _C ≤ +125°C unless otherwise specified	Group A Subgroups	Device type	Limits		Unit	
				Min	Max		
High Level output voltage	V _{OH}	V _{CC} = 4.5 V, V _{IL} = 0.8V I _{OH} = -2.0 mA, V _{IH} = 2.0 V	1,2,3	All	2.4	V	
Low level output voltage	V _{OL}	V _{CC} = 4.5 V, I _{OL} = 12.0V V _{IL} = 0.8 V, V _{IH} = 2.0 V	1,2,3	All	0.5	V	
High level input voltage 1/	V _{IH}		1,2,3	All	2.0	7.0	V
Low level input voltage 1/	V _{IL}		1,2,3	All	0.5	0.8	V
Input leakage current	I _{IX}	V _{CC} = 5.5 V, V _{IN} = 0 V and 5.5 V	1,2,3	All	-10	+10	μA
Output leakage current	I _{OZ}	V _{CC} = 5.5 V, V _{IN} = output disabled and 5.5 V	1,2,3	All	-50	+50	μA
Output short circuit current 2/ 3/	I _{OS}	V _{CC} = 5.5 V, V _{OUT} = 0.5 V	1,2,3	All	-30	-90	mA
Power supply current 4/	I _{CC}	V _{CC} = 5.5 V, I _{OUT} = 0 mA, V _{IN} = 0 V and 5.5 V f = 1.0 MHz	1,2,3	All		370	mA
Input capacitance 2/	C _{IN}	See 4.4.1e	4	All		10	pF
Output capacitance 2/	C _{OUT}	See 4.4.1e	4	All		12	pF
Functional test		See 4.4.1c	7,8A,8B	All			
Input to combinatorial output 5/	t _{PD}	See figures 3 and 4 (circuit A)	9,10,11	01		20	ns
				02		15	
Input to output through transparent input or output latch 5/ 6/	t _{PDL}			01		22	ns
				02		18	
Input to output through transparent input or output latches 5/ 6/	t _{PDLL}			01		24	ns
				02		19	
Input to output enable 5/ 6/	t _{EA}			01		24	ns
				02		19	
Input to output disable 5/ 6/	t _{ER}			01		24	ns
				02		19	
Clock or Latch enable input High time 2/ 5/	t _{WH}	See figures 3 and 4 (circuit A)		01	5	ns	
				02	4		

See footnotes at end of table.

STANDARD MICROCIRCUIT DRAWING DEFENSE ELECTRONICS SUPPLY CENTER DAYTON, OHIO 45444	SIZE A		5962-94713
		REVISION LEVEL	SHEET 6

DESC FORM 193A
JUL 94

9004708 0019945 T21

TABLE I. Electrical performance characteristics - Continued.

Test	Symbol	Conditions 4.5 V ≤ V _{CC} ≤ 5.5 V -55°C ≤ T _C ≤ +125°C unless otherwise specified	Group A Subgroups	Device type	Limits		Unit
					Min	Max	
Clock or latch enable input low time 2/ 5/	t _{WL}	See figures 3 and 4 (circuit A)	9,10,11	01	5		ns
				02	4		
Input register or latch set-up time 5/	t _{IS}			01	4		ns
				02	3		
Input register or latch hold time 5/	t _{IH}			01	4		ns
				02	3		
Input register clock or latch enable to combinatorial output 5/	t _{ICO}			01		24	ns
				02		19	
Input register clock or latch enable to output through transparent output latch 5/ 6/	t _{ICOL}			01		26	ns
				02		21	
Clock or latch enable to output 5/	t _{CO}			01		10	ns
				02		8	
Register or latch data hold time 5/	t _H			All	0		ns
Set-up time from input to clock or latch enable 5/	t _S	01	10		ns		
		02	8				
Set-up time from input through transparent latch to output register clock or latch enable 5/ 6/	t _{SL}	01	20		ns		
		02	15				
Output clock or latch enable to output delay (through memory array) 5/ 6/	t _{CO2}	01		24	ns		
		02		19			
Output clock or latch enable to output clock or latch enable (through memory array) 5/ 6/	t _{SCS}	01	15		ns		
		02	12				
Hold time for input through transparent latch from output register clock or latch enable 5/ 6/	t _{HL}	All	0		ns		

See footnotes at end of table.

STANDARD MICROCIRCUIT DRAWING DEFENSE ELECTRONICS SUPPLY CENTER DAYTON, OHIO 45444	SIZE A		5962-94713
		REVISION LEVEL	SHEET 7

DESC FORM 193A
JUL 94

9004708 0019946 968

TABLE I. Electrical performance characteristics - Continued.

Test Symbol	Conditions 4.5 V ≤ V _{CC} ≤ 5.5 V -55°C ≤ T _C ≤ +125°C unless otherwise specified	Group A Subgroups	Device type	Limits		Unit
				Min	Max	
Maximum frequency with internal feedback in output register mode (least of 1/t _{SCS} , 1/(t _S + 1/t _H), or 1/t _{CO}) 2/ 5/	f _{MAX1}	9,10,11	01	66		MHz
			02	83		
Maximum frequency data path in output register/latched mode (lesser of 1/(t _{WL} + t _{WH}), 1/(t _S + t _H), or 1/t _{CO}) 2/ 5/	f _{MAX2}	9,10,11	01	100		MHz
			02	125		
Maximum frequency with external feedback (lesser of 1/(t _{CO} + t _S) or 1/(t _{WL} + t _{WH}) 2/ 5/	f _{MAX3}	9,10,11	01	50		MHz
			02	67.5		
Maximum frequency in pipelined mode (least of 1/(t _{CO} + t _{IS}), 1/t _{ICS} , 1/(t _{WL} + t _{WH}), 1/(t _{IS} + t _{IH}), or 1/t _{SCS}) 2/ 5/	f _{MAX4}	9,10,11	01	66.6		MHz
			02	83.3		
Output data stable from	t _{DH}		All	0		ns
Input register clock to output register clock 5/	t _{ICS}	9,10,11	01	15		ns
			02	12		
Asynchronous preset width 2/ 5/ 6/	t _{PW}	9,10,11	01	20		ns
			02	15		
Asynchronous preset recovery time 2/ 5/ 6/	t _{PR}	9,10,11	01	22		ns
			02	17		
Asynchronous preset to output 5/ 6/	t _{PO}	9,10,11	01		26	ns
			02		21	
Asynchronous reset width 5/ 6/	t _{RW}	9,10,11	01	20		ns
			02	15		
Asynchronous reset recovery time 5/ 6/	t _{RR}	9,10,11	01	22		ns
			02	17		
Asynchronous reset to output 5/ 6/	t _{RO}	9,10,11	01		26	ns
			02		21	
Power on reset 2/ 5/	t _{POR}		All		1	μs

See footnotes at end of table.

STANDARD MICROCIRCUIT DRAWING DEFENSE ELECTRONICS SUPPLY CENTER DAYTON, OHIO 45444	SIZE A		5962-94713
		REVISION LEVEL	SHEET 8

DESC FORM 193A
JUL 94

9004708 0019947 8T4

TABLE I. Electrical performance characteristics - Continued.

- 1/ These are absolute ratings with respect to device ground, and all overshoots due to system or tester noise are included.
- 2/ Tested initially and after any design or process changes that affect this parameter.
- 3/ Not more than one output should be tested at a time. Duration of the short circuit should not exceed 1 second. $V_{OUT} = 0.5$ V has been chosen to avoid test problems caused by tester ground degradation.
- 4/ Measured with 16-bit counter programmed into each logic block.
- 5/ All AC parameters are measured with 16 outputs switching.
- 6/ May not be tested but shall be guaranteed to the limits specified in table I.
- 7/ This specification is intended to guarantee interface compatibility with the other members of the device family, contact manufacturer for additional information.

4.4 Conformance inspection. Technology conformance inspection for classes Q and V shall be in accordance with MIL-PRF-38535 including groups A, B, C, D, and E inspections and as specified herein except where option 2 of MIL-PRF-38535 permits alternate in-line control testing. Quality conformance inspection for device class M shall be in accordance with MIL-PRF-38535, appendix A and as specified herein. Inspections to be performed for device class M shall be those specified in method 5005 of MIL-STD-883 and herein for groups A, B, C, D, and E inspections (see 4.4.1 through 4.4.4).

4.4.1 Group A inspection.

- a. Tests shall be as specified in table IIA herein.
- b. Subgroups 5 and 6 of table I of method 5005 of MIL-STD-883 shall be omitted.
- c. For device class M subgroups 7, 8A and 8B tests shall consist of verifying functionality of the device. These tests form a part of the vendors test tape and shall be maintained and available upon request. For device classes Q and V subgroups 7, 8A and 8B shall include verifying the functionality of the device; these tests shall have been fault graded in accordance with MIL-STD-883, test method 5012 (see 1.5 herein).
- d. O/V (latch-up) tests shall be measured only for initial qualification and after any design or process changes which may affect the performance of the device. For device class M procedures and circuits shall be maintained under document revision level control by the manufacturer and shall be made available to the preparing activity or acquiring activity upon request. For device classes Q and V, the procedures and circuits shall be under the control of the device manufacturer's technical review board (TRB) in accordance with MIL-PRF-38535 and shall be made available to the preparing activity or acquiring activity upon request. Testing shall be on all pins, on 5 devices with zero failures. Latch-up test shall be considered destructive. Information contained in JEDEC Standard number 17 may be used for reference.
- e. Subgroup 4 (C_{IN} and C_{OUT} measurements) shall be measured only for initial qualification and after any process or design changes which may affect input or output capacitance. Capacitance shall be measured between the designated terminal and GND at a frequency of 1 MHz. Sample size is three devices with no failures, and all input and output terminals tested.

4.4.2 Group C inspection. The group C inspection end-point electrical parameters shall be as specified in table IIA herein. Delta limits shall apply only to subgroup 1 of group C inspection and shall consist of tests specified in table IIB herein.

4.4.2.1 Additional criteria for device class M. Steady-state life test conditions, method 1005 of MIL-STD-883:

- a. Test condition D. For device class M, the test circuit shall be maintained by the manufacturer under document revision level control and shall be made available to the preparing or acquiring activity upon request. For device classes M the test circuit shall specify the inputs, outputs, biases, and power dissipation, as applicable, in accordance with the intent specified in test method 1005.
- b. $T_A = +125^\circ\text{C}$, minimum.
- c. Test duration: 1,000 hours, except as permitted by method 1005 of MIL-STD-883.

STANDARD MICROCIRCUIT DRAWING DEFENSE ELECTRONICS SUPPLY CENTER DAYTON, OHIO 45444	SIZE A		5962-94713
		REVISION LEVEL	SHEET 9

Case outline X

[查询"5962-947130"供应商](#)

Terminal number	Terminal symbol	Terminal number	Terminal symbol
A1	I/O	G1	CLK/I
A2	I/O	G2	I/O
A3	I/O	G3	GND
A4	I/O	G9	CLK/I
A5	V _{CC}	G10	I/O
A6	GND	G11	I/O
A7	I/O	H1	I/O
A8	I/O	H2	I/O
A9	I/O	H10	I/O
A10	I/O	H11	I/O
A11	I/O	J1	I/O
B1	I/O	J2	I/O
B2	GND	J5	I/O
B3	I/O	J6	V _{CC}
B4	I/O	J7	GND
B5	I/O	J10	I/O
B6	I/O	J11	I/O
B7	I/O	K1	I/O
B8	I/O	K2	GND
B9	I/O	K3	I/O
B10	GND	K4	I/O
B11	I/O	K5	I/O
C1	I/O	K6	I
C2	I/O	K7	I/O
C5	I/O	K8	I/O
C6	V _{CC}	K9	I/O
C7	I	K10	GND
C10	I/O	K11	I/O
C11	I/O	L1	I/O
D1	I/O	L2	I/O
D2	I/O	L3	I/O
D10	I/O	L4	I/O
D11	I/O	L5	I/O
E1	I/O	L6	I/O
E2	I/O	L7	V _{CC}
E3	I/O	L8	I/O
E9	I/O	L9	I/O
E10	I/O	L10	I/O
E11	CLK/I	L11	I/O
F1	I/O		
F2	CLK/I		
F3	V _{CC}		
F9	V _{CC}		
F10	I/O		
F11	GND		

FIGURE 1. Terminal connections.

STANDARD
MICROCIRCUIT DRAWING
DEFENSE ELECTRONICS SUPPLY CENTER
DAYTON, OHIO 45444

SIZE
A

5962-94713

REVISION LEVEL

SHEET

10

Case outline Y

Device type	ALL	Device type	ALL	Device type	ALL
Terminal number	Terminal symbol	Terminal number	Terminal symbol	Terminal number	Terminal symbol
1	GND	29	I/O	57	I/O
2	V _{CC}	30	I/O	58	I/O
3	I/O	31	I/O	59	I/O
4	I/O	32	GND	60	I/O
5	I/O	33	I/O	61	I/O
6	I/O	34	I/O	62	CLK/I
7	I/O	35	I/O	63	V _{CC}
8	I/O	36	I/O	64	GND
9	I/O	37	I/O	65	CLK/I
10	I/O	38	I/O	66	I/O
11	GND	39	I/O	67	I/O
12	I/O	40	I/O	68	I/O
13	I/O	41	I	69	I/O
14	I/O	42	V _{CC}	70	I/O
15	I/O	43	GND	71	I/O
16	I/O	44	V _{CC}	72	I/O
17	I/O	45	I/O	73	I/O
18	I/O	46	I/O	74	GND
19	I/O	47	I/O	75	I/O
20	CLK/I	48	I/O	76	I/O
21	V _{CC}	49	I/O	77	I/O
22	GND	50	I/O	78	I/O
23	CLK/I	51	I/O	79	I/O
24	I/O	52	I/O	80	I/O
25	I/O	53	GND	81	I/O
26	I/O	54	I/O	82	I/O
27	I/O	55	I/O	83	I
28	I/O	56	I/O	84	V _{CC}

FIGURE 1. Terminal connections - Continued.

STANDARD MICROCIRCUIT DRAWING DEFENSE ELECTRONICS SUPPLY CENTER DAYTON, OHIO 45444	SIZE A		5962-94713
		REVISION LEVEL	SHEET 11

DESC FORM 193A
JUL 94

■ 9004708 0019950 399 ■

Truth table		
Input pins		Output pins
I/CLK	I	I/O
X	X	Z

- NOTES:
 1. X = Don't care
 2. Z = High impedance

FIGURE 2. Truth table (unprogrammed).

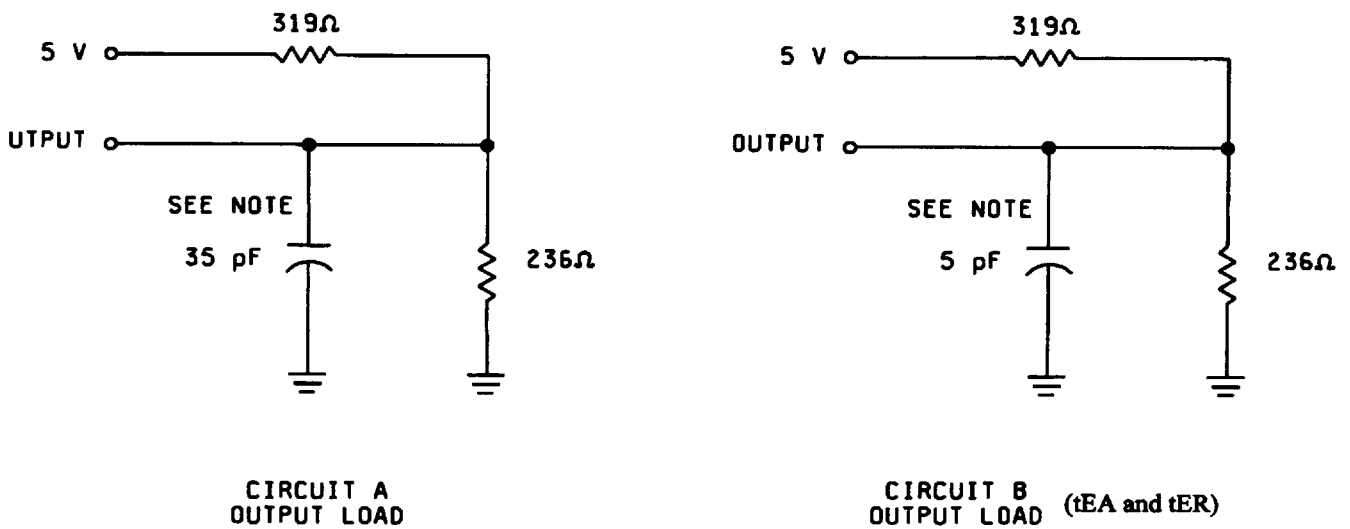

THEVENIN EQUIVALENT

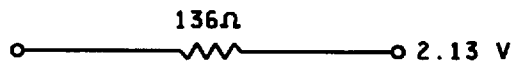

NOTE: INCLUDING SCOPE AND JIG (MINIMUM VALUES).

FIGURE 3. Output load circuits and test conditions.

STANDARD MICROCIRCUIT DRAWING DEFENSE ELECTRONICS SUPPLY CENTER DAYTON, OHIO 45444	SIZE A		5962-94713
		REVISION LEVEL	SHEET 12

Test Waveforms

Input pulses

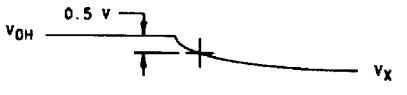
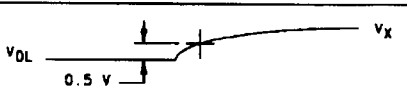
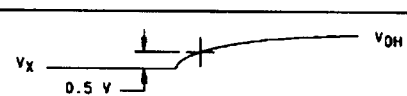
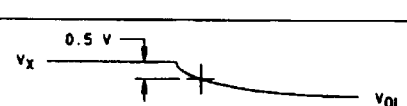
PARAMETER	V _X	OUTPUT WAVEFORM - MEASUREMENT LEVEL
t _{ER(-)}	1.5 V	
t _{ER(+)}	2.6 V	
t _{EA(+)}	1.5 V	
t _{EA(-)}	V _{LHC}	

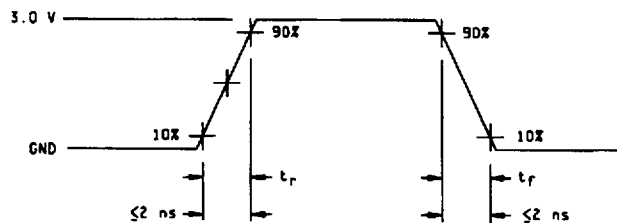

FIGURE 3. Output load circuits and test conditions - Continued.

STANDARD MICROCIRCUIT DRAWING DEFENSE ELECTRONICS SUPPLY CENTER DAYTON, OHIO 45444	SIZE A		5962-94713
		REVISION LEVEL	SHEET 13

DESC FORM 193A
JUL 94

9004708 0019952 161

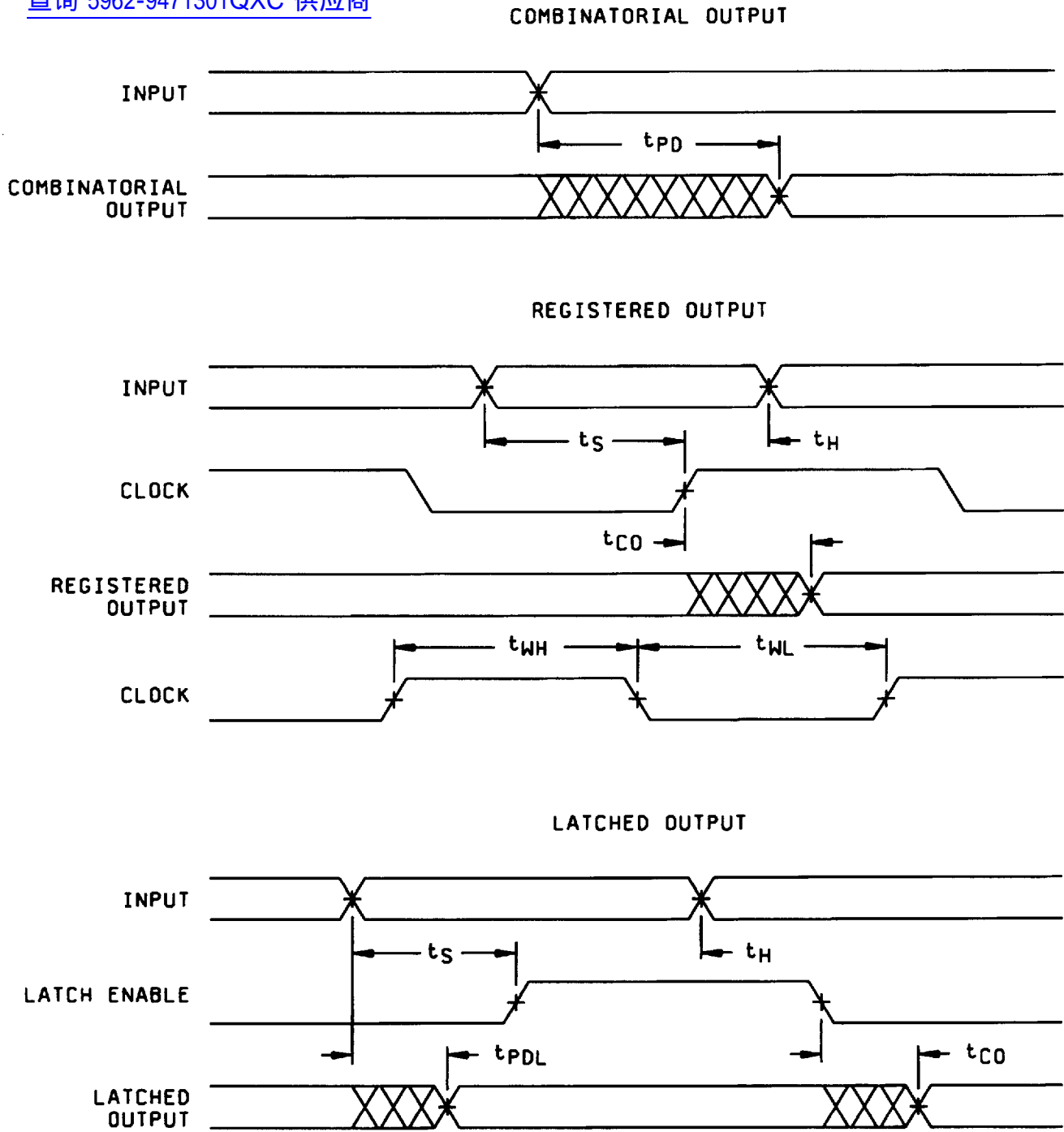

FIGURE 4. Switching waveforms.

STANDARD MICROCIRCUIT DRAWING DEFENSE ELECTRONICS SUPPLY CENTER DAYTON, OHIO 45444	SIZE A		5962-94713
		REVISION LEVEL	SHEET 14

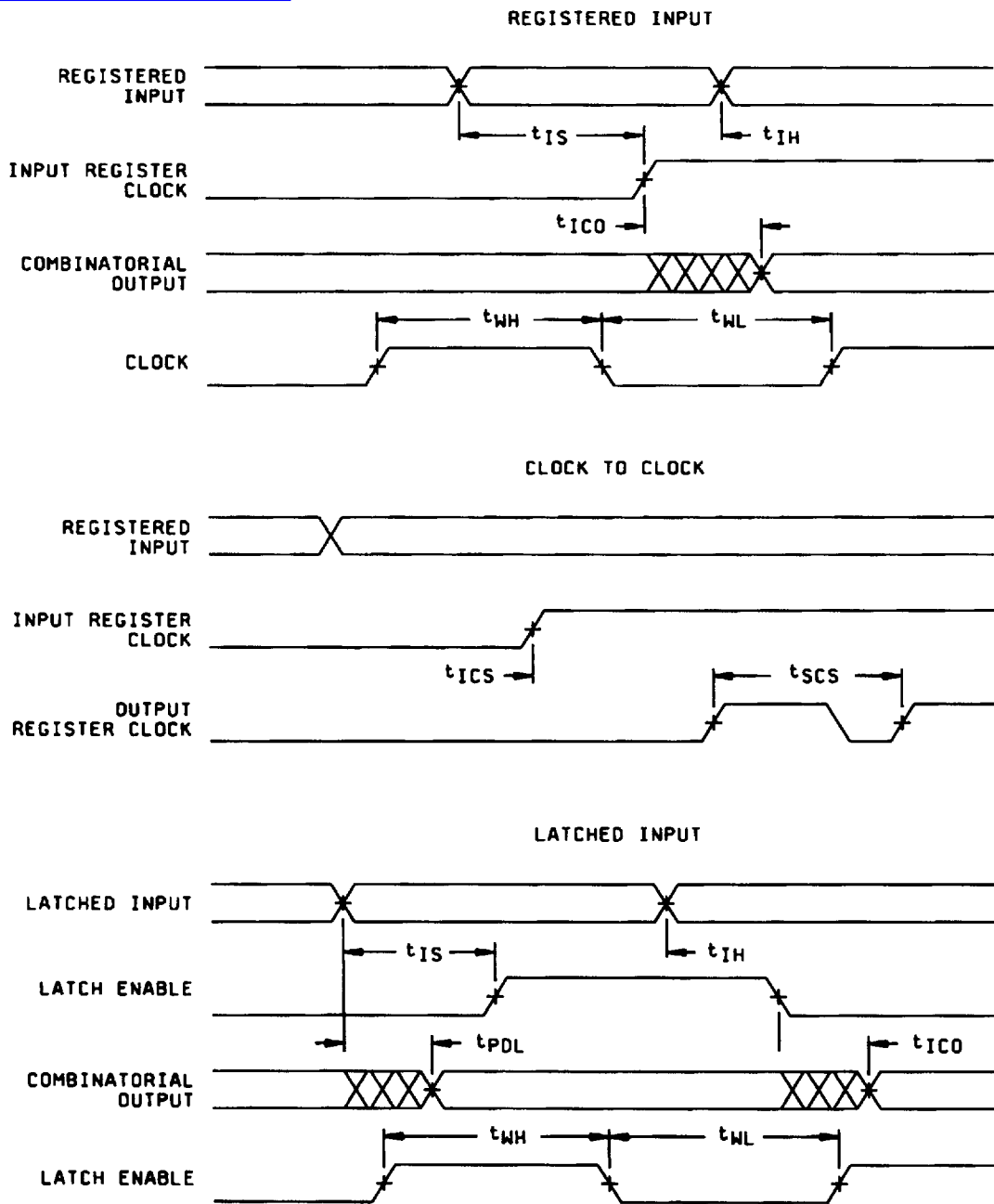
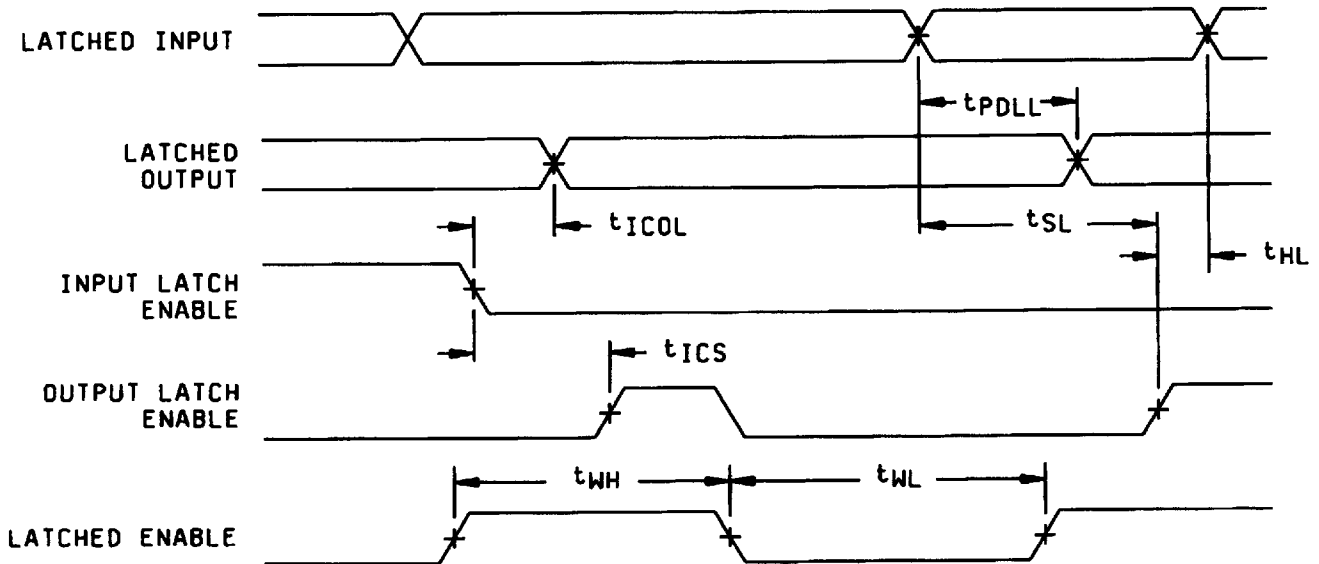

FIGURE 4. Switching waveforms - Continued.

STANDARD MICROCIRCUIT DRAWING DEFENSE ELECTRONICS SUPPLY CENTER DAYTON, OHIO 45444	SIZE A		5962-94713
		REVISION LEVEL	SHEET 15

LATCHED INPUT AND OUTPUT



ASYNCHRONOUS RESET

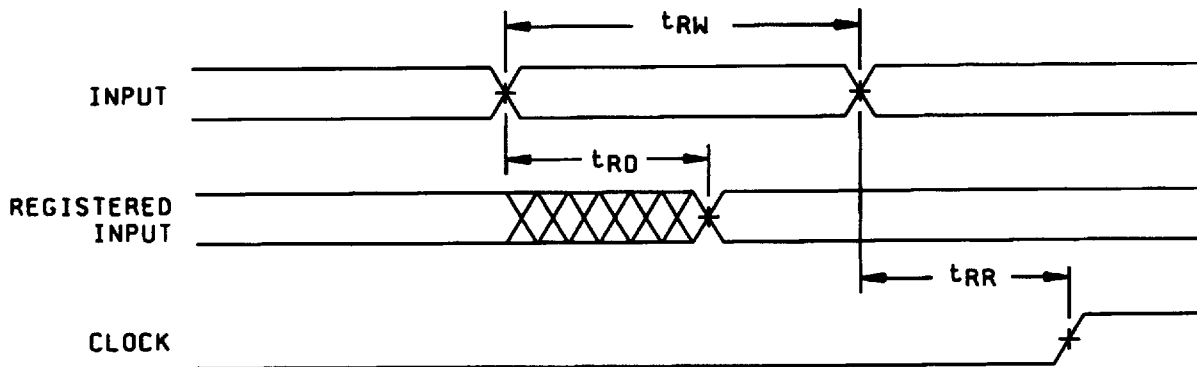

FIGURE 4. Switching waveforms - Continued.

STANDARD MICROCIRCUIT DRAWING DEFENSE ELECTRONICS SUPPLY CENTER DAYTON, OHIO 45444	SIZE A		5962-94713
		REVISION LEVEL	SHEET 16

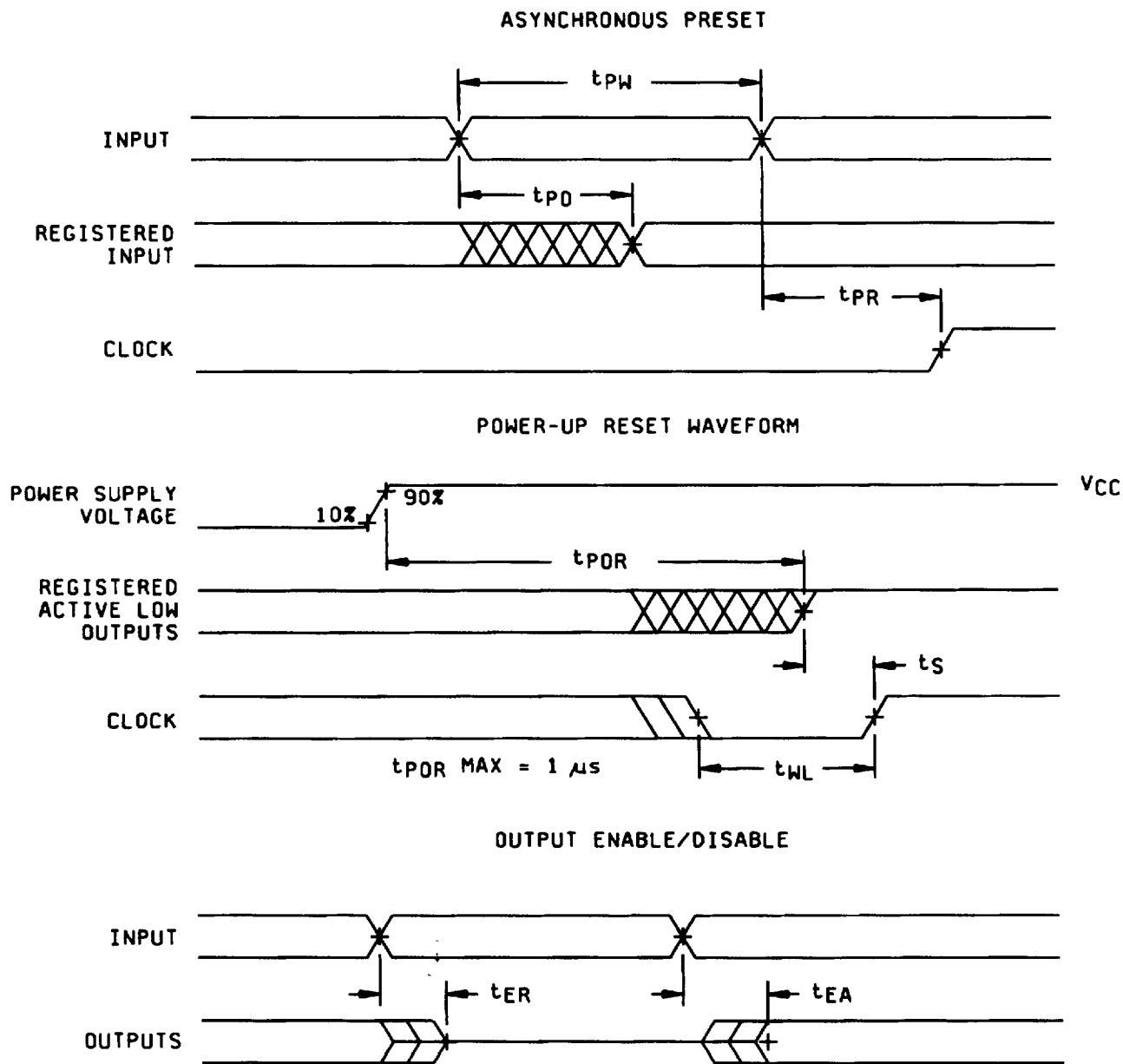

FIGURE 4. Switching waveforms - Continued.

STANDARD MICROCIRCUIT DRAWING DEFENSE ELECTRONICS SUPPLY CENTER DAYTON, OHIO 45444	SIZE A		5962-94713
		REVISION LEVEL	SHEET 17

DESC FORM 193A
JUL 94

9004708 0019956 807

TABLE IIA. Electrical test requirements. 1/ 2/ 3/ 4/ 5/ 6/ 7/

查询"5962-9471301QXC"供应商

Line no.	Test requirements	Subgroups (in accordance with MIL-STD-883, method 5005, table I)		
		Device class M	Device class Q	Device class V
1	Interim electrical parameters (see 4.2)		1,7,9	1,7,9 or 2,8A,10
2	Static burn-in (method 1015)	Not Required	Not Required	Required
3	Same as line 1			1*,7* Δ
4	Dynamic burn-in (method 1015)	Required	Required	Required
5	Final electrical parameters	1*,2,3,7*,8A,8B,9,10,11	1*,2,3,7*,8A,8B,9,10,11	1*,2,3,7*,8A,8B,9,10,11
6	Group A test requirements	1,2,3,4**,7,8A,8B,9,10,11	1,2,3,4**,7,8A,8B,9,10,11	1,2,3,4**,7,8A,8B,9,10,11
7	Group C end-point electrical parameters	2,3,7,8A,8B	2,3,7,8A,8B	1,2,3,7,8A,8B,9,10,11 Δ
8	Group D end-point electrical parameters	2,3,8A,8B	2,3,8A,8B	2,3,8A,8B
9	Group E end-point electrical parameters	1,7,9	1,7,9	1,7,9

- 1/ Blank spaces indicate tests are not applicable.
- 2/ Any or all subgroups may be combined when using high-speed testers.
- 3/ Subgroups 7 and 8 functional tests shall verify the truth table.
- 4/ * indicates PDA applies to subgroup 1 and 7.
- 5/ ** see 4.4.1e.
- 6/ Δ indicates delta limit (see table IIB) shall be required where specified, and the delta values shall be computed with reference to the previous interim electrical parameters (see line 1).
- 7/ See 4.4.1d.

TABLE IIB. Delta limits at +25°C.

Parameter 1/	Device types
	All
¹ OZ	±10% of the specified value in table I
¹ IX	±10% of the specified value in table I

- 1/ The above parameter shall be recorded before and after the required burn-in and life tests to determine the delta Δ.

STANDARD MICROCIRCUIT DRAWING DEFENSE ELECTRONICS SUPPLY CENTER DAYTON, OHIO 45444	SIZE A		5962-94713
		REVISION LEVEL	SHEET 18

4.4.2.2 Additional criteria for device classes Q and V. The steady-state life test duration, test condition and test temperature, or approved alternatives shall be as specified in the device manufacturer's QM plan in accordance with MIL-PRF-38535. The test circuit shall be maintained under document revision level control by the device manufacturer's TRB in accordance with MIL-PRF-38535 and shall be made available to the acquiring or preparing activity upon request. The test circuit shall specify the inputs, outputs, biases, and power dissipation, as applicable, in accordance with the intent specified in test method 1005 of MIL-STD-883.

4.4.3 Group D inspection. The group D inspection end-point electrical parameters shall be as specified in table IIA herein.

4.4.4 Group E inspection. Group E inspection is required only for parts intended to be marked as radiation hardness assured (see 3.5 herein). RHA levels for device classes Q and V shall be M, D, L, R, F, G, and H and for device class M shall be M and D.

- a. End-point electrical parameters shall be as specified in table IIA herein.
- b. For device classes Q and V, the devices or test vehicle shall be subjected to radiation hardness assured tests as specified in MIL-PRF-38535 for the RHA level being tested. For device class M, the devices shall be subjected to radiation hardness assured tests as specified in MIL-PRF-38535, appendix A for the RHA level being tested. All device classes must meet the postirradiation end-point electrical parameter limits as defined in table I at $T_A = +25^{\circ}\text{C} \pm 5^{\circ}\text{C}$, after exposure, to the subgroups specified in table IIA herein.
- c. When specified in the purchase order or contract, a copy of the RHA delta limits shall be supplied.

4.5 Delta measurements for device class V. Delta measurements, as specified in table IIA, shall be made and recorded before and after the required burn-in screens and steady-state life tests to determine delta compliance. The electrical parameters to be measured, with associated delta limits are listed in table IIB. The device manufacturer may, at his option, either perform delta measurements or within 24 hours after life test perform final electrical parameter tests, subgroups 1, 7, and 9.

4.6 Erasure procedures. Erasure procedures shall be as specified by the device manufacturer and shall be made available upon request.

4.7 Programming procedures. The programming procedures shall be as specified by the device manufacturer and shall be made available upon request.

5. PACKAGING

5.1 Packaging requirements. The requirements for packaging shall be in accordance with MIL-PRF-38535 for device classes Q and V or MIL-PRF-38535, appendix A for device class M.

6. NOTES

6.1 Intended use. Microcircuits conforming to this drawing are intended for use for Government microcircuit applications (original equipment), design applications, and logistics purposes.

6.1.1 Replaceability. Microcircuits covered by this drawing will replace the same generic device covered by a contractor-prepared specification or drawing.

6.1.2 Substitutability. Device class Q devices will replace device class M devices.

6.2 Configuration control of SMD's. All proposed changes to existing SMD's will be coordinated with the users of record for the individual documents. This coordination will be accomplished in accordance with MIL-STD-973 using DD Form 1692, Engineering Change Proposal.

6.3 Record of users. Military and industrial users should inform Defense Electronics Supply Center when a system application requires configuration control and which SMD's are applicable to that system. DESC will maintain a record of users and this list will be used for coordination and distribution of changes to the drawings. Users of drawings covering microelectronic devices (FSC 5962) should contact DESC-EC, telephone (513) 296-6047.

6.4 Comments. Comments on this drawing should be directed to DESC-EC, Dayton, Ohio 45444-5270, or telephone (513) 296-5377.

6.5 Abbreviations, symbols, and definitions. The abbreviations, symbols, and definitions used herein are defined in MIL-PRF-38535, MIL-HDBK-1331.

6.6 Sources of supply.

6.6.1 Sources of supply for device classes Q and V. Sources of supply for device classes Q and V are listed in QML-38535. The vendors listed in QML-38535 have submitted a certificate of compliance (see 3.6 herein) to DESC-EC and have agreed to this drawing.

6.6.2 Approved sources of supply for device class M. Approved sources of supply for class M are listed in MIL-HDBK-103. The vendors listed in MIL-HDBK-103 have agreed to this drawing and a certificate of compliance (see 3.6 herein) has been submitted to and accepted by DESC-EC.

STANDARD MICROCIRCUIT DRAWING DEFENSE ELECTRONICS SUPPLY CENTER DAYTON, OHIO 45444	SIZE A		5962-94713
		REVISION LEVEL	SHEET 19