

High Intensity Red Low Current Seven Segment Display

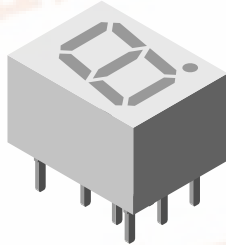

19235

DESCRIPTION

This series defines a new standard for low current displays. It is a single digit 7-segment LED display utilizing AlInGaP technology in color red.

The supreme light intensity allows applications under direct sunlight or "black front" designs by using tinted filter glass in front of the display.

Typical 1500 μcd at 1 mA is best in class performance for applications with very limited power supply. The maximum forward current of 10 mA is allowed for an ambient temperature range of - 40 °C to + 85 °C without current derating.

Crosstalk between segments is possible at drive currents above 5 mA per segment. Therefore it is recommend to apply more than 5 mA only under direct sunlight or with tinted filter glass.

FEATURES

- 1500 μcd typical at 1 mA
- Very low power consumption
- Wide viewing angle
- Grey package surface
- Light intensity categorized at $I_F = 1 \text{ mA}$
- Compliant to RoHS directive 2002/95/EC and in accordance to WEEE 2002/96/EC



RoHS
COMPLIANT

APPLICATIONS

- Battery driven instruments
- Telecom devices
- Home appliances
- Instrumentation
- POS terminals

PRODUCT GROUP AND PACKAGE DATA

- Product group: display
- Package: 7 mm
- Product series: low current
- Angle of half intensity: $\pm 50^\circ$

PARTS TABLE

PART	COLOR	LUMINOUS INTENSITY AT 1 mA	CIRCUITRY
TDSR0750	Red	$I_V = (180 \text{ to } 2200) \mu\text{cd}$	Common anode
TDSR0750-HI	Red	$I_V = (700 \text{ to } 2200) \mu\text{cd}$	Common anode
TDSR0760	Red	$I_V = (180 \text{ to } 2200) \mu\text{cd}$	Common cathode

ABSOLUTE MAXIMUM RATINGS ⁽¹⁾ TDSR0750, TDSR0750-HI, TDSR0760

PARAMETER	TEST CONDITION	SYMBOL	VALUE	UNIT
Reverse voltage per segment		V_R	5	V
DC forward current per segment		I_F	10	mA
Peak forward current per segment	$t_p \leq 10 \mu\text{s}$, duty cycle 1/10	I_{FM}	50	mA
Power dissipation	$T_{amb} \leq 85^\circ\text{C}$	P_V	185	mW
Junction temperature		T_j	105	$^\circ\text{C}$
Operating temperature range		T_{amb}	- 40 to + 85	$^\circ\text{C}$
Storage temperature range		T_{stg}	- 40 to + 85	$^\circ\text{C}$
Soldering temperature	$t \leq 3 \text{ s}$, 2 mm below seating plane	T_{sd}	260	$^\circ\text{C}$
Thermal resistance LED junction/ambient		R_{thJA}	100	K/W

Note

(1) $T_{amb} = 25^\circ\text{C}$, unless otherwise specified



TDSR0750, TDSR0760



Vishay Semiconductors

High Intensity Red Low Current
Seven Segment Display

OPTICAL AND ELECTRICAL CHARACTERISTICS ⁽¹⁾ TDSR0750, TDSR0750-HI, TDSR0760, RED							
PARAMETER	TEST CONDITION	PART	SYMBOL	MIN.	TYP.	MAX.	UNIT
Luminous intensity per segment (digit average)	$I_F = 1 \text{ mA}$	TDSR0750	I_V	180	-	2200	μcd
		TDSR0760		180	-	2200	
		TDSR0750-HI		700	-	2200	
Dominant wavelength	$I_F = 1 \text{ mA}$	TDSR0750, TDSR0750-HI, TDSR0760	λ_d	-	640	-	nm
Peak wavelength	$I_F = 1 \text{ mA}$		λ_p	-	650	-	nm
Forward voltage per segment or DP	$I_F = 1 \text{ mA}$		V_F	-	1.8	2.4	V
Reverse voltage per segment or DP	$V_R = 6 \text{ V}$		I_R	-	10	-	μA

Note

(1) $T_{\text{amb}} = 25 \text{ }^\circ\text{C}$, unless otherwise specified

LUMINOUS INTENSITY CLASSIFICATION			
GROUP	LIGHT INTENSITY (μcd)		
	STANDARD	MIN.	MAX.
E		180	360
F		280	560
G		450	900
H		700	1400
I		1100	2200

Note

The above type numbers represent the order groups which include only a few brightness groups. Only one group will be shipped in one tube (there will be no mixing of two groups in one tube). In order to ensure availability, single brightness groups will not be orderable.

TYPICAL CHARACTERISTICS

$T_{\text{amb}} = 25 \text{ }^\circ\text{C}$, unless otherwise specified

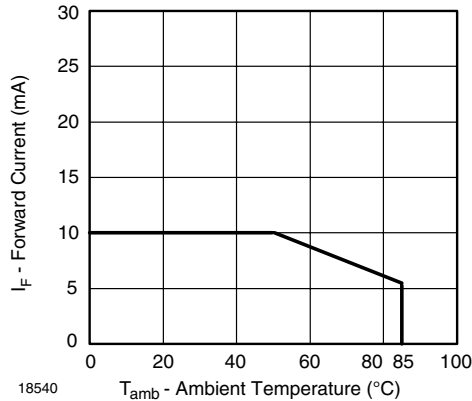

Fig. 1 - Forward Current vs. Ambient Temperature

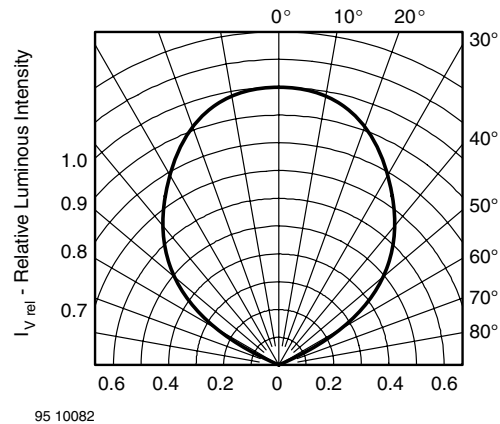

Fig. 2 - Rel. Luminous Intensity vs. Angular Displacement

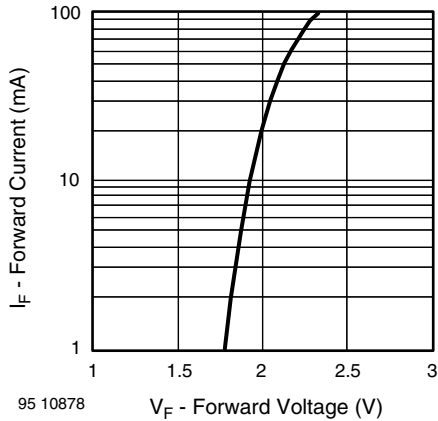

Fig. 3 - Forward Current vs. Forward Voltage

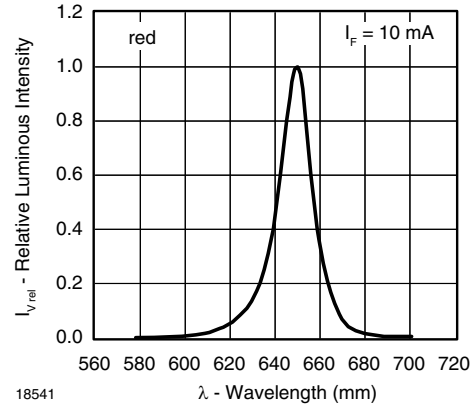

Fig. 6 - Rel. Luminous Intensity vs. Ambient Temperature

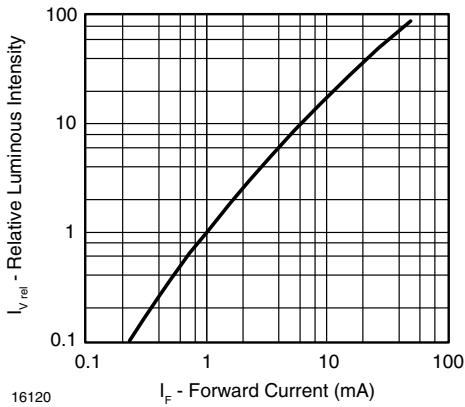

Fig. 4 - Relative Luminous Intensity vs. Forward Current

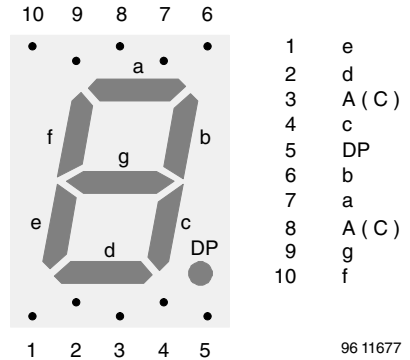

Fig. 7 - TDSR07..

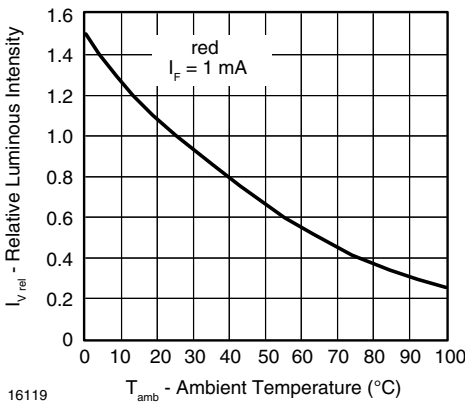

Fig. 5 - Rel. Luminous Intensity vs. Ambient Temperature

TDSR0750, TDSR0760



Vishay Semiconductor

High Intensity Red Low Current
Seven Segment Display

PACKAGE DIMENSIONS FOR TDSR07.. in millimeters

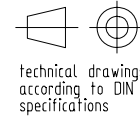
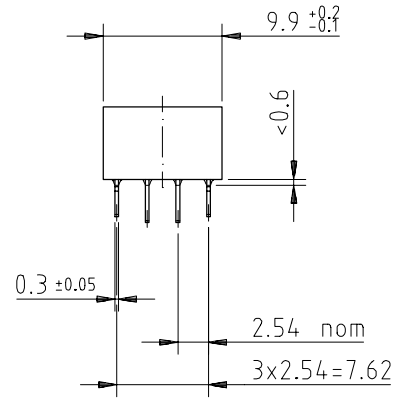
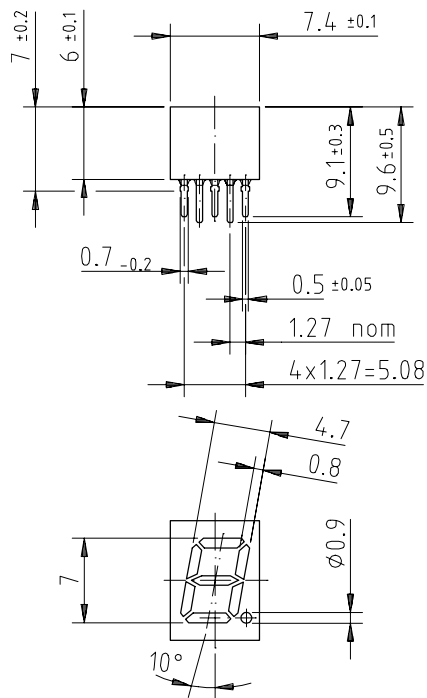

Drawing-No.: 6.544-5083.01-4
Issue: 1; 21.11.95
95 11342

Disclaimer

All product specifications and data are subject to change without notice.

Vishay Intertechnology, Inc., its affiliates, agents, and employees, and all persons acting on its or their behalf (collectively, "Vishay"), disclaim any and all liability for any errors, inaccuracies or incompleteness contained herein or in any other disclosure relating to any product.

Vishay disclaims any and all liability arising out of the use or application of any product described herein or of any information provided herein to the maximum extent permitted by law. The product specifications do not expand or otherwise modify Vishay's terms and conditions of purchase, including but not limited to the warranty expressed therein, which apply to these products.

No license, express or implied, by estoppel or otherwise, to any intellectual property rights is granted by this document or by any conduct of Vishay.

The products shown herein are not designed for use in medical, life-saving, or life-sustaining applications unless otherwise expressly indicated. Customers using or selling Vishay products not expressly indicated for use in such applications do so entirely at their own risk and agree to fully indemnify Vishay for any damages arising or resulting from such use or sale. Please contact authorized Vishay personnel to obtain written terms and conditions regarding products designed for such applications.

Product names and markings noted herein may be trademarks of their respective owners.