

**Specifications and Applications
Information**

MONOLITHIC VOLTAGE REGULATOR

The MC1569/MC1469 is a positive voltage regulator designed to deliver continuous load current up to 500 mA dc. Output voltage is adjustable from 2.5 V dc to 37 V dc. The MC1569 is specified for use within the military temperature range (-55 to +125°C) and the MC1469 within the 0 to +70°C temperature range.

For systems requiring a positive regulated voltage, the MC1569 can be used with performance nearly identical to the MC1563 negative voltage regulator. Systems requiring both a positive and negative regulated voltage can use the MC1569 and MC1563 as complementary regulators with a common input ground.

- Electronic "Shut-Down" Control
- Excellent Load Regulation (Low Output Impedance - 20 milliohms typ)
- High Power Capability: up to 17.5 Watts
- Excellent Temperature Stability: ±0.002 %/°C typ
- High Ripple Rejection: 0.002 %/V typ

**FIGURE 1 - ±15 V, ±400 mA COMPLEMENTARY TRACKING
VOLTAGE REGULATOR**

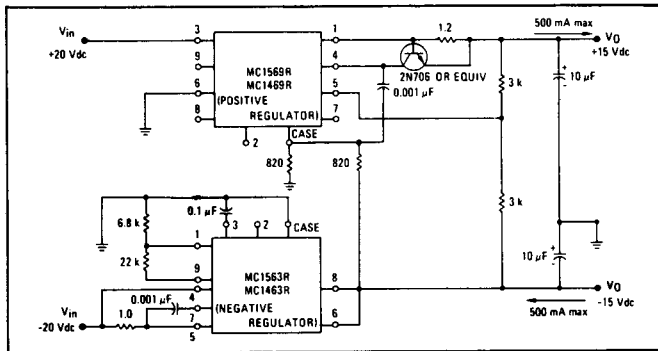

**FIGURE 2 - TYPICAL CIRCUIT CONNECTION
(3.5 ≤ V_O ≤ 37 V dc, 1 ≤ I_L ≤ 500 mA)**

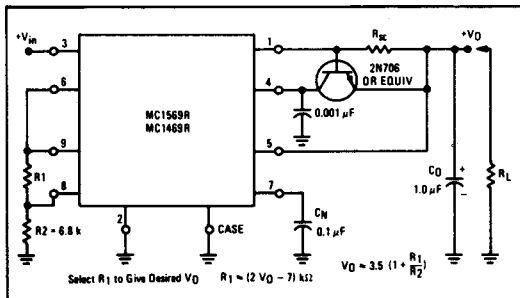

**FIGURE 3 - TYPICAL NPN CURRENT BOOST CONNECTION
(V_O = 5.0 V dc, I_L = 10 A dc (max))**

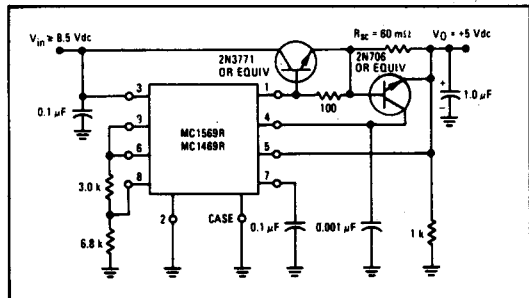

**POSITIVE VOLTAGE REGULATOR
INTEGRATED CIRCUIT**

**SILICON MONOLITHIC
EPITAXIAL PASSIVATED**



**G SUFFIX
METAL PACKAGE
CASE 603-04**

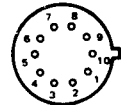

(Bottom View)

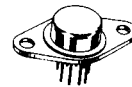

**R SUFFIX
METAL PACKAGE
CASE 614-02**

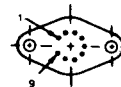

(Bottom View)

ORDERING INFORMATION

DEVICE	TEMPERATURE RANGE	PACKAGE
MC1469G	0° C to +70° C	Metal Can
MC1469R	0° C to +70° C	Metal Power
MC1569G	-55° C to +125° C	Metal Can
MC1569R	-55° C to +125° C	Metal Power

MC1469, MC1569

MAXIMUM RATINGS ($T_C = +25^\circ\text{C}$ unless otherwise noted)

Rating	Symbol	Value	Unit
Input Voltage	V_{in}	35 40	Vdc
Peak Load Current	I_{PK}	G Package: 250 R Package: 600	mA
Current, Pin 2	$I_{pin 2}$	10	mA
Current, Pin 9	$I_{pin 9}$	5.0	mA
Power Dissipation and Thermal Characteristics			
$T_A = +25^\circ\text{C}$	P_D	0.68	Watts
Derate above $T_A = +25^\circ\text{C}$	$1/\theta_{JA}$	5.44	mW/ $^\circ\text{C}$
Thermal Resistance, Junction to Air	θ_{JA}	184	$^\circ\text{C}/\text{W}$
$T_C = +25^\circ\text{C}$	P_D	1.8	Watts
Derate above $T_C = +25^\circ\text{C}$	$1/\theta_{JC}$	14.4	mW/ $^\circ\text{C}$
Thermal Resistance, Junction to Case	θ_{JC}	69.4	$^\circ\text{C}/\text{W}$
Operating and Storage Junction Temperature	T_J, T_{stg}	-65 to +150	$^\circ\text{C}$

OPERATING TEMPERATURE RANGE

Ambient Temperature	T_A	$^\circ\text{C}$
MC1469 MC1569	0 to +70 -55 to +125	

ELECTRICAL CHARACTERISTICS

($T_C = +25^\circ\text{C}$ unless otherwise noted) (Load Current = 100 mA for "R" Package device, unless otherwise noted)
= 10 mA for "G" Package device,

Characteristic	Fig.	Note	Symbol	MC1569			MC1469			Unit
				Min	Typ	Max	Min	Typ	Max	
Input Voltage ($T_A = T_{low}$ ① to T_{high} ②)	4	1	V_{in}	8.5	—	40	9.0	—	35	Vdc
Output Voltage Range	4,5		V_O	2.5	—	37	2.5	—	32	Vdc
Reference Voltage (Pin 8 to Ground, $V_{in} = 15\text{ V}$)	4		V_{ref}	3.4	3.5	3.6	3.2	3.5	3.8	Vdc
Minimum Input-Output Voltage Differential ($R_{sc} = 0$)	4	2	$V_{in} - V_O$	—	2.1	2.7	—	2.1	3.0	Vdc
Bias Current ($V_{in} = 15\text{ V}$) ($I_L = 1.0\text{ mAdc}$, $R_2 = 6.8\text{ k ohms}$, $I_{IB} = I_{in} - I_L$)	4		I_{IB}	—	4.0	9.0	—	5.0	12	mAdc
Output Noise ($C_N = 0.1\ \mu\text{F}$, $f = 10\text{ Hz}$ to 5.0 MHz)	4		V_n	—	0.150	—	—	0.150	—	mV(rms)
Temperature Coefficient of Output Voltage	4	3	TCV_O	—	± 0.002	—	—	± 0.002	—	%/ $^\circ\text{C}$
Operating Load Current Range ($R_{sc} \leq 0.3\text{ ohms}$) R Package ($R_{sc} \leq 2.0\text{ ohms}$) G Package	4		I_L	1.0 1.0	— —	500 200	1.0 1.0	— —	500 200	mAdc
Input Regulation	6	4	Reg_{line}	—	0.002	0.015	—	0.003	0.030	%/ V_O
Load Regulation ($T_J = \text{Constant}$ [$1.0\text{ mA} \leq I_L \leq 20\text{ mA}$]) R Package ($T_C = +25^\circ\text{C}$ [$1.0\text{ mA} \leq I_L \leq 50\text{ mA}$]) R Package G Package	7	5	Reg_{load}	— — —	0.4 0.005 0.01	1.6 0.05 0.13	— — —	0.7 0.005 0.01	2.4 0.05 0.13	mV %
Output Impedance ($C_C = 0.001\ \mu\text{F}$, $R_{sc} = 1.0\text{ ohm}$, $f = 1.0\text{ kHz}$, $V_{in} = +14\text{ Vdc}$, $V_O = +10\text{ Vdc}$)	8	6	z_O	—	20	—	—	35	—	milliohms
Shutdown Current ($V_{in} = +35\text{ Vdc}$)	9		I_{sd}	—	70	150	—	140	500	μAdc

① $T_{low} = 0^\circ\text{C}$ for MC1469
= -55°C for MC1569

② $T_{high} = +70^\circ\text{C}$ for MC1469
= $+125^\circ\text{C}$ for MC1569

Note 1. "Minimum Input Voltage" is the minimum "total instantaneous input voltage" required to properly bias the internal zener reference diode. For output voltages greater than 5.0 Vdc, the minimum "total instantaneous input voltage" must increase to the extent that it will always exceed the output voltage by at least the "input-output voltage differential".

Note 2. This parameter states that the MC1569/MC1469 will regulate properly with the input-output voltage differential ($V_{in} - V_O$) as low as 2.7 Vdc and 3.0 Vdc respectively. Typical units will regulate properly with ($V_{in} - V_O$) as low as 2.1 Vdc as shown in the typical column. (See Figure 2.1.)

Note 3. "Temperature Coefficient of Output Voltage" is defined as:

$$MC1569, TCV_O = \frac{\pm (V_O \text{ max} - V_O \text{ min}) (100)}{(180^\circ C) (V_O @ 25^\circ C)} = \%/^\circ C$$

$$MC1469, TCV_O = \frac{\pm (V_O \text{ max} - V_O \text{ min}) (100)}{(75^\circ C) (V_O @ 25^\circ C)} = \%/^\circ C$$

The output-voltage adjusting resistors (R1 and R2) must have matched temperature characteristics in order to maintain a constant ratio independent of temperature.

Note 4. Input regulation is the percentage change in output voltage per volt change in the input voltage and is expressed as

$$\text{Input Regulation} = \frac{V_O}{V_O (v_{in})} 100 (\%/V_O)$$

where v_O is the change in the output voltage V_O for the input change v_{in} .

The following example illustrates how to compute maximum output voltage change for the conditions given:

$$\begin{aligned} \text{Regline} &= 0.015 \%/V_O \\ V_O &= 10 \text{ Vdc} \\ v_{in} &= 1.0 \text{ V (rms)} \\ v_O &= \frac{\text{Regline} (v_{in}) (V_O)}{100} \\ &= \frac{(0.015) (1.0) (10)}{100} \\ &= 0.0015 \text{ V (rms)} \end{aligned}$$

Note 5. Load regulation is specified for small ($\leq +17^\circ C$) changes in junction temperature. Temperature drift effect must be taken into account separately for conditions of high junction temperature changes due to the thermal feedback that exists on the monolithic chip.

$$\text{Load Regulation} = \frac{[V_O]_{I_L = 1.0 \text{ mA}} - [V_O]_{I_L = 50 \text{ mA}}}{V_O |_{I_L = 1.0 \text{ mA}}} \times 100$$

Note 6. The resulting low level output signal (v_O) will require the use of a tuned voltmeter to obtain a reading. Special care should be used to insure that the measurement technique does not include connection resistance, wire resistance, and wire lead inductance (i.e., measure close to the case). Note that No. 22 AWG hook-up wire has approximately 4.0 milliohms/in. dc resistance and an inductive reactance of approximately 10 milliohms/in. at 100 kHz. Avoid use of alligator clips or banana plug-jack combination.

TEST CIRCUITS

FIGURE 4 - CONNECTION FOR $V_O \geq 3.5 \text{ Vdc}$

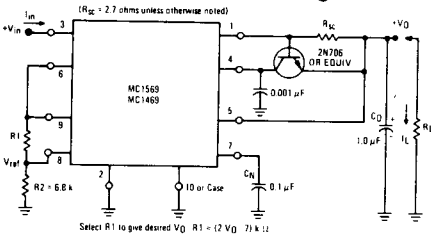

Select R1 to give desired V_O . R1 = (2 V_O) k Ω .

FIGURE 5 - CONNECTION FOR $2.5 \text{ Vdc} \geq V_O \leq 3.5 \text{ Vdc}$

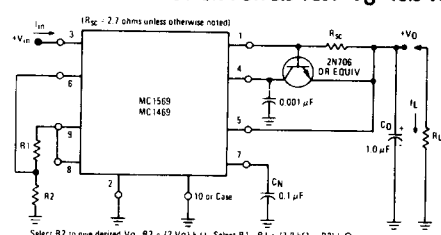

Select R2 to give desired V_O . R2 = (2 V_O) k Ω . Select R1 = (7.0 k Ω - R2) k Ω .

FIGURE 6 - INPUT REGULATION

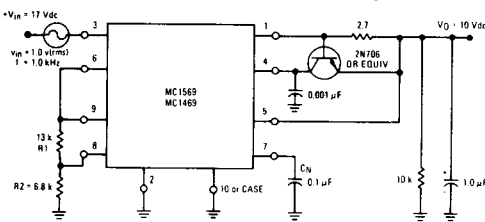

FIGURE 7 - LOAD REGULATION

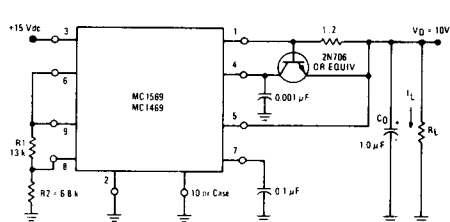

FIGURE 8 - OUTPUT IMPEDANCE

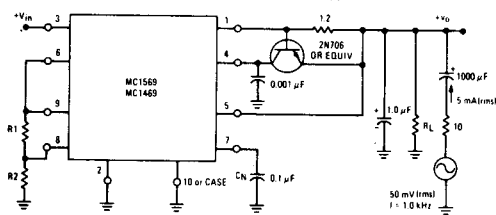
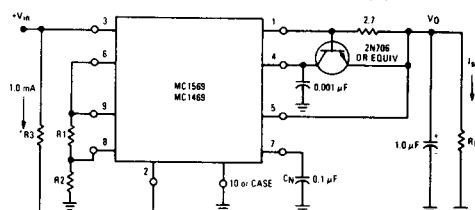

FIGURE 9 - SHUTDOWN CURRENT



R3 = ($V_{in} - 1.5$) k Ω .

GENERAL DESIGN INFORMATION

1. Output Voltage, V_O

For $V_O \geq 3.5$ Vdc, the output voltage is set by resistors R1 and R2 (see Figure 4). Set R2 = 6.8 k ohms and determine R1 from the graph of Figure 10 or from the equation:

$$R1 \approx (2 V_O - 7) \text{ k}\Omega$$

b) For $2.5 \leq V_O \leq 3.5$ Vdc - Output voltage is set by resistors R1 and R2 (see Figure 5). Resistors R1 and R2 can be determined from the graph of Figure 11 or from the equations:

$$R2 \approx 2 (V_O) \text{ k}\Omega$$

$$R1 \approx (7 \text{ k}\Omega - R2) \text{ k}\Omega$$

- c) Output voltage, V_O , is determined by the ratio of R1 and R2, therefore optimum temperature performance can be achieved if R1 and R2 have the same temperature coefficient.
- d) Output voltage can be varied by making R1 adjustable as shown in Figure 43.
- e) If $V_O = 3.5$ Vdc (to supply MRTL* for example), tie pins 6, 8 and 9 together. R1 and R2 are not needed in this case.

2. Short Circuit Current, I_{sc}

Short Circuit Current, I_{sc} , is determined by R_{sc} . R_{sc} may be chosen with the aid of Figure 12 or the expression:

$$R_{sc} \approx \frac{0.6 \text{ ohm}}{I_{sc}}$$

where I_{sc} is measured in amperes. This expression is also valid when current is boosted as shown in Figure 2.

3. Compensation, C_C

A 0.001 μF capacitor, C_C , from pin 4 to ground will provide adequate compensation in most applications, with or without current boost. Smaller values of C_C will reduce stability and larger values of C_C will degrade pulse response and output impedance versus frequency. The physical location of C_C should be close to the MC1569/MC1469 with short lead lengths.

4. Noise Filter Capacitor, C_N

A 0.1 μF capacitor, C_N , from pin 7 to ground will typically reduce the output noise voltage to 150 μV (rms). The value of C_N can be increased or decreased, depending on the noise voltage requirements of a particular application. A minimum value of 0.001 μF is recommended.

5. Output Capacitor, C_O

The value of C_O should be at least 1.0 μF in order to provide good stability. The maximum value recommended is a function of current limit resistor R_{sc} :

$$C_O \text{ max} \approx \frac{250 \mu\text{F}}{R_{sc}}$$

where R_{sc} is measured in ohms. Values of C_O greater than this will degrade the pulse response characteristics and increase the settling time.

6. Shut-Down Control

One method of turning "OFF" the regulator is to apply a dc voltage at pin 2. This control can be used to eliminate power consumption by circuit loads which can be put in "standby" mode. Examples include, an ac or dc "squelch" control for communications circuits, and a dissipation control to protect the regulator under sustained output short-circuiting. As the magnitude of the input-threshold voltage at Pin 2 depends directly upon the junction temperature of the integrated circuit chip, a fixed dc voltage at Pin 2 will cause automatic shut-down for high junction temperatures. This will protect the chip, independent of the heat sinking used, the ambient temperature, or the input or output voltage levels. Standard Logic levels of MRTL*, MDTL* or MTTL* can also be used to turn the regulator "ON" or "OFF".

7. Remote Sensing

The connection to pin 5 can be made with a separate lead direct to the load. Thus, "remote sensing" can be achieved and the effect of undesired impedances (including that of the milliammeter used to measure I_L) on Z_O can be greatly reduced.

FIGURE 10 - R1 versus V_O
($V_O \geq 3.5$ Vdc, See Figure 4)

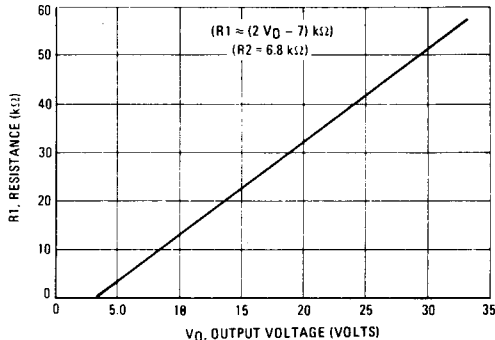

FIGURE 11 - R1 and R2 versus V_O
($2.5 \leq V_O \leq 3.5$ Vdc, See Figure 5)

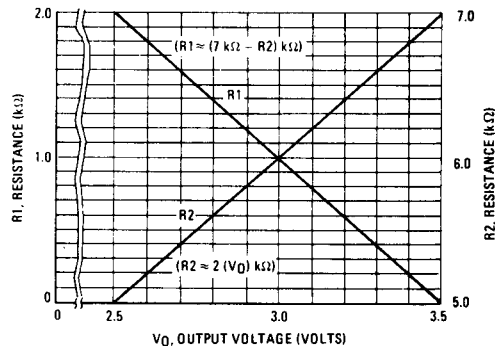
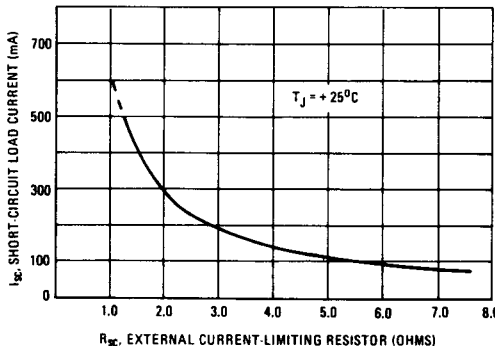

FIGURE 12 - I_{sc} versus R_{sc}



TYPICAL CHARACTERISTICS

Unless otherwise noted: $C_N = 0.1 \mu F$, $C_C = 0.001 \mu F$, $C_O = 1.0 \mu F$, $T_C = +25^\circ C$,
 $V_{in \text{ nom}} = +9.0 \text{ Vdc}$, $V_O \text{ nom} = +5.0 \text{ Vdc}$,
 $I_L > 200 \text{ mA}$ for R package only.

查询"MC1469R"供应商

FIGURE 13 – DEPENDENCE OF OUTPUT IMPEDANCE ON OUTPUT VOLTAGE

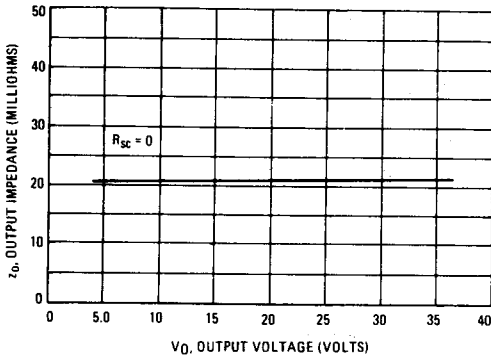

FIGURE 14 – OUTPUT IMPEDANCE versus R_{sc}

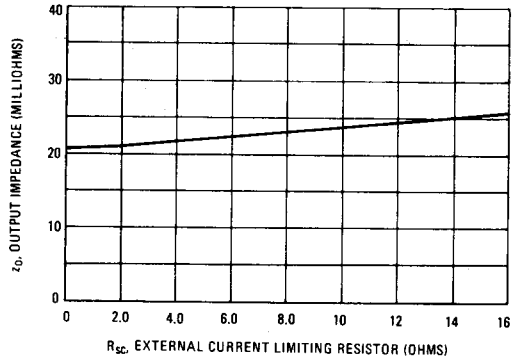

FIGURE 15 – FREQUENCY DEPENDENCE OF INPUT REGULATION, $C_O = 10 \mu F$

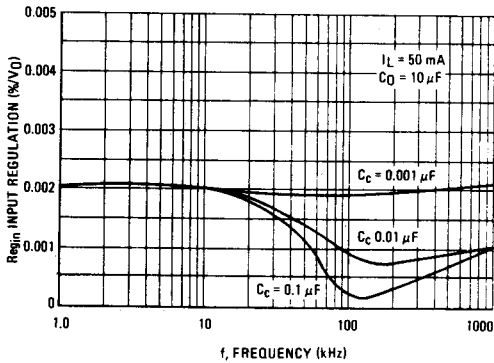

FIGURE 16 – FREQUENCY DEPENDENCE OF INPUT REGULATION, $C_O = 2.0 \mu F$

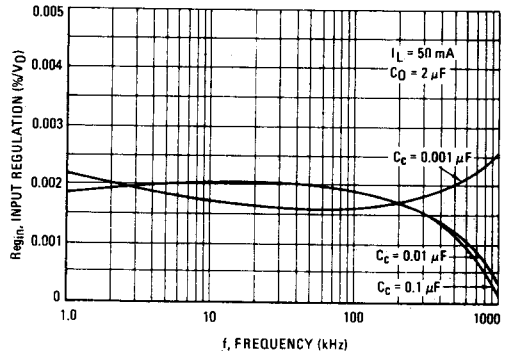

FIGURE 17 – CURRENT-LIMITING CHARACTERISTICS

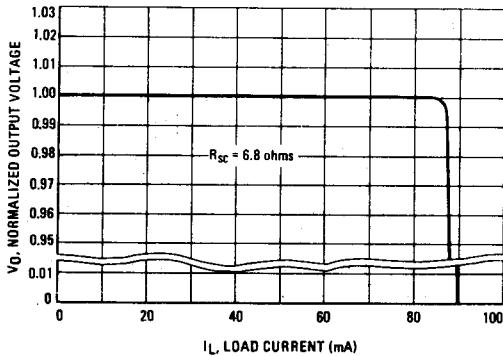
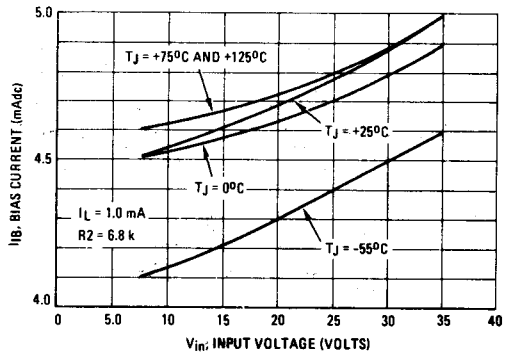

FIGURE 18 – BIAS CURRENT versus INPUT VOLTAGE



TYPICAL CHARACTERISTICS (continued)

查询"MC1469R"供应商

Unless otherwise noted: $C_N = 0.1 \mu F$, $C_C = 0.001 \mu F$, $C_O = 1.0 \mu F$, $T_C = +25^\circ C$,

$V_{in} \text{ nom} = +9.0 \text{ Vdc}$, $V_O \text{ nom} = +5.0 \text{ Vdc}$,

$I_L > 200 \text{ mA}$ for R package only.

FIGURE 19 – EFFECT OF LOAD CURRENT ON INPUT-OUTPUT VOLTAGE DIFFERENTIAL

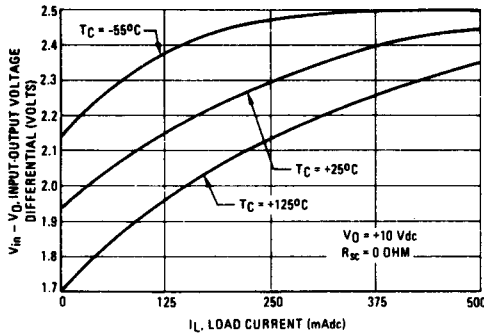

FIGURE 20 – EFFECT OF INPUT-OUTPUT VOLTAGE DIFFERENTIAL ON INPUT REGULATION

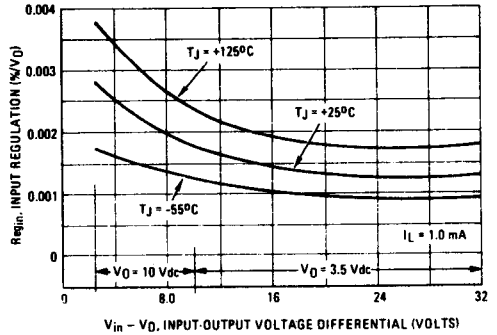

FIGURE 21 – INPUT TRANSIENT RESPONSE

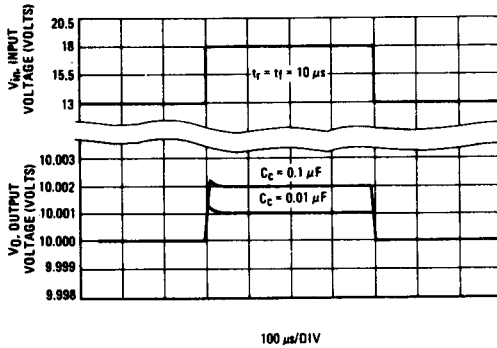

FIGURE 22 – TEMPERATURE DEPENDENCE OF SHORT-CIRCUIT LOAD CURRENT

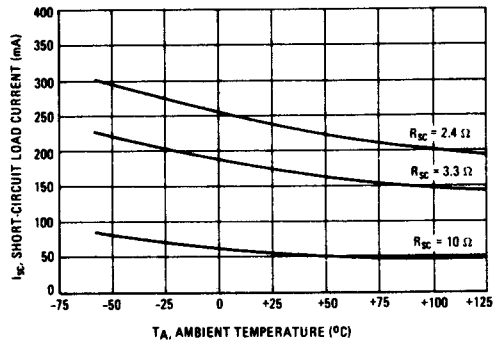

FIGURE 23 – FREQUENCY DEPENDENCE OF OUTPUT IMPEDANCE, $C_O = 10 \mu F$

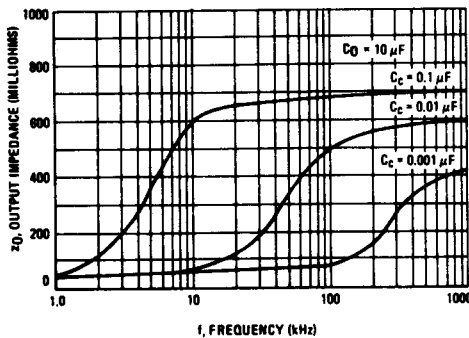
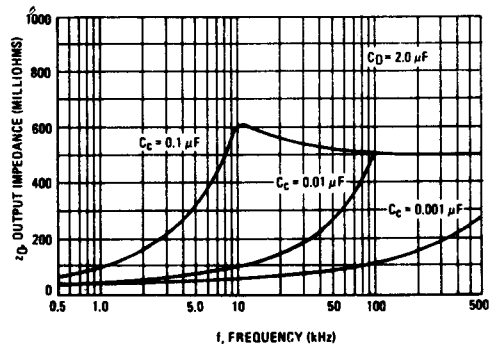

FIGURE 24 – FREQUENCY DEPENDENCE OF OUTPUT IMPEDANCE, $C_O = 2.0 \mu F$



查询"MC1469R"供应商 OPERATIONS AND APPLICATIONS

This section describes the operation and design of the MC1569 positive voltage regulator and also provides information on useful applications.

SUBJECT SEQUENCE

Theory of Operation NPN Current Boosting PNP Current Boosting Switching Regulator Positive and Negative Power Supplies	Shutdown Techniques Voltage Boosting Remote Sensing An Adjustable-Zero-Temperature-Coefficient Voltage Source	Thermal Shutdown Thermal Considerations Latch-Up
--	--	--

THEORY OF OPERATION

The usual series voltage regulator shown in Figure 25, consists of a reference voltage, an error amplifier, and a series control element. The error amplifier compares the output voltage with the reference voltage and adjusts the output accordingly until the error is essentially zero. For applications requiring output voltages larger than the reference, there are two options. The first is to use a resistive divider across the output and compare only a fraction of the output voltage to the reference. This approach suffers from reduced feedback to the error amplifier due to the attenuation of the resistive divider. This degrades load regulation especially at high voltage levels.

The alternative is to eliminate the resistive divider and to shift the reference voltage instead. To accomplish this, another amplifier is employed to amplify (or level shift) the reference voltage using an operational amplifier as shown in Figure 26. The gain-determining resistors may be external, enabling a wide range of output voltages. This

is exactly the same approach used in the first option. That is, the output is being resistively divided to match the reference voltage. There is however, one big difference in that the output of this "regulator" is driving the input of another regulator (the error amplifier). The output of the reference amplifier has a relatively low impedance as compared to the input impedance of the error amplifier. Changes in the load of the output of the error amplifier are buffered to the extent that they have virtually no effect on the reference amplifier. If the feedback resistors are external (as they are on the MC1569) a wide range of reference voltages can be established.

The error amplifier can now be operated at unity gain to provide excellent regulation. In fact, this "regulator-within-a-regulator" concept permits the load regulation to be specified in terms of output impedance rather than as some percentage change of the output voltage. This approach was used in the design of the MC1569 positive-voltage regulator.

FIGURE 25 - SERIES VOLTAGE REGULATOR

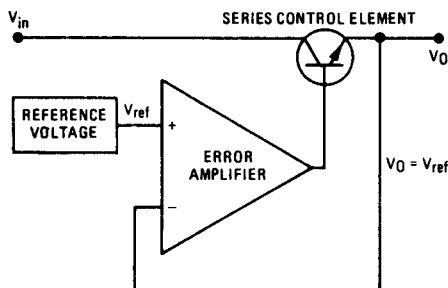
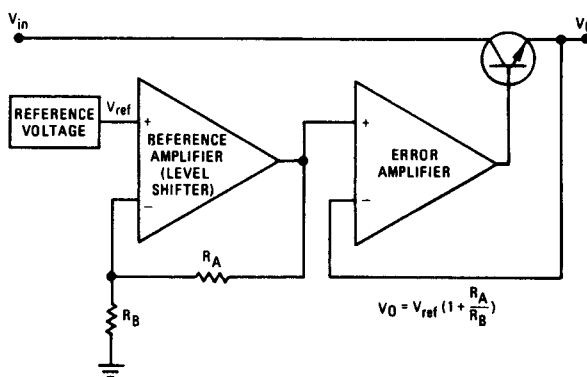
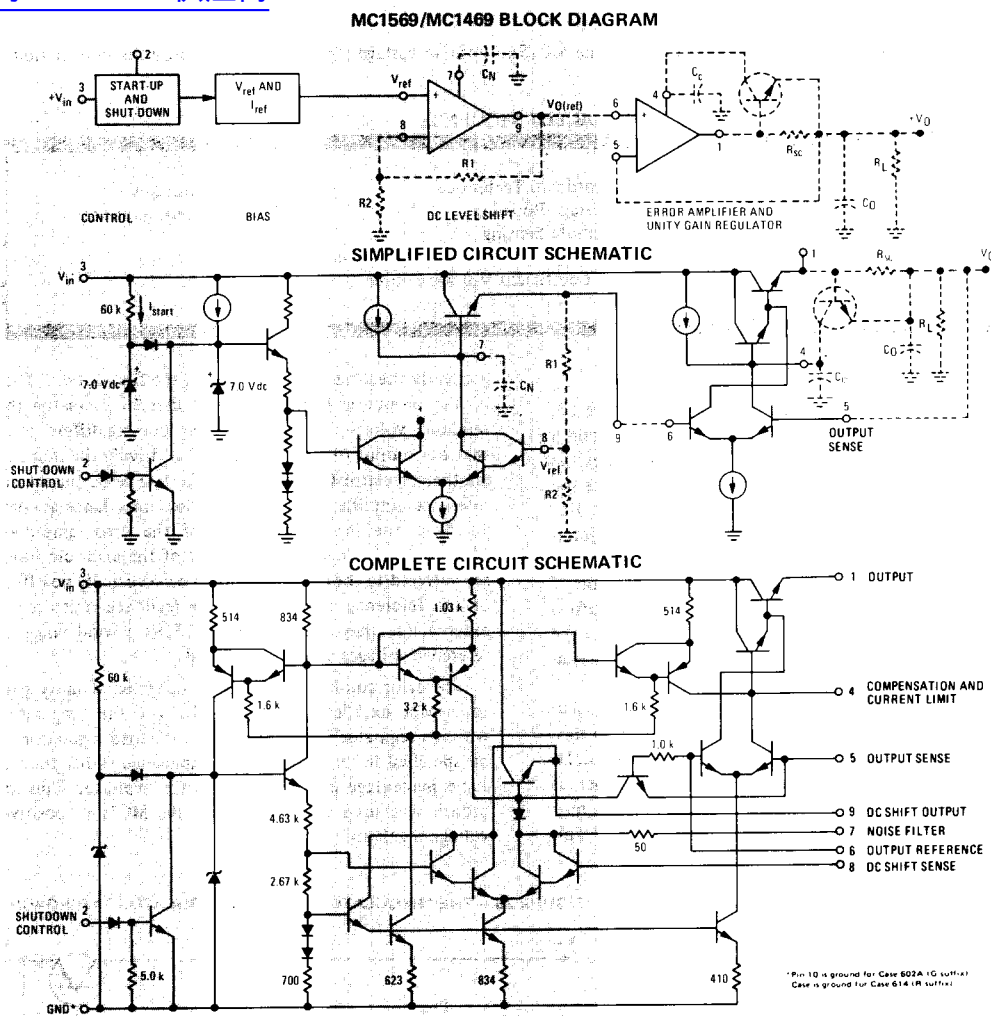

FIGURE 26 - THE "REGULATOR-WITHIN-A-REGULATOR" APPROACH



查询"MC1469R"供应商 (Recommended External Circuitry is Depicted With Dotted Lines.)

FIGURE 27



4

MC1569 Operation

Figure 27 shows the MC1569 Regulator block diagram, simplified schematic, and complete schematic. The four basic sections of the regulator are: Control, Bias, DC Level Shift, and Output (unity gain) Regulator. Each section is detailed in the following paragraphs.

Control

The control section involves two basic functions, start-up and shutdown. A start-up function is required since the biasing is essentially independent of the unregulated

input voltage. It makes use of two zener diodes having the same breakdown voltage. A first or auxiliary zener is driven directly from the input voltage line through a resistor (60 kΩ) and permits the regulator to initially achieve the desired bias conditions. This permits the second, or reference zener to be driven from a current source. When the reference zener enters breakdown, the auxiliary zener is isolated from the rest of the regulator circuitry by a diode disconnect technique. This is necessary to keep the added noise and ripple of the auxiliary zener from degrading the performance of the regulator.

The shutdown control consists of an NPN transistor across the reference zener diode. When this transistor is turned "ON", via pin 2, the reference voltage is reduced to essentially zero volts and the regulator is forced to shut-down. During shutdown the current drain of the complete IC regulator drops to $V_{in}/60\text{ k}\Omega$ or $500\text{ }\mu\text{A}$ for a 30 V input.

Bias

A zener diode is the main reference element and forms the heart of the bias circuitry. Its positive temperature coefficient is balanced by the negative temperature coefficients of forward biased diodes in a ratio determined by the resistors in the diode string. The result is a reference voltage of approximately 3.5 Vdc with a typical temperature coefficient of $0.002\text{ }\%/^{\circ}\text{C}$. In addition, this circuit also provides a reference current which is used to bias all current sources in the remaining regulator circuitry.

DC Level Shift

The reference voltage is used as the input to a Darlington differential amplifier. The gain of this amplifier is quite high and it therefore may be considered to function as a conventional operational amplifier. Consequently, negative feedback can be employed using two external resistors (R1 and R2) to set the closed-loop gain and to boost the reference voltage to the desired output voltage. A capacitor, C_N , is introduced externally into the level shift network (via pin 7) to stabilize the amplifier and to filter the zener noise. The recommended value for this capacitor is $0.1\text{ }\mu\text{F}$ and should have a voltage rating in excess of the desired output voltage. Smaller capacitors ($0.001\text{ }\mu\text{F}$ minimum) may be used but will cause a slight increase in output noise. Larger values of C_N will reduce the noise as well as delay the start-up of the regulator.

Output Regulator

The output of the level shift amplifier (pin 9) is fed to the noninverting input (pin 6) of the output error amplifier. The inverting input to this amplifier is the Output Sense connection (pin 5) of the regulator. A Darlington connected NPN power transistor is used to handle the load current. The short-circuit current limiting resistor, R_{SC} , is connected in the emitter of this transistor to sample the full load current. By placing an external low-level NPN transistor across R_{SC} as shown in Figure 27, output current can be limited to a predetermined value:

$$I_L \text{ max} \approx \frac{0.6}{R_{SC}} \text{ or } R_{SC} = \frac{0.6}{I_L \text{ max}}$$

where $I_L \text{ max}$ is the maximum load current (amperes) and R_{SC} is the value of the current limiting resistor (ohms).

Stability and Compensation

As has been seen, the MC1569 employs two amplifiers, each using negative feedback. This implies the possibility of instability due to excessive phase shift at high frequencies. Since the error amplifier is normally used at unity gain (the worst case for stability) a high impedance node is brought out for compensation. For normal operation, a capacitor is connected between this point (pin 4) and ground. The recommended value of $0.001\text{ }\mu\text{F}$ will insure stability and still provide acceptable transient response (see Figure 28, A and B). It is also necessary to use an output capacitor, C_O (typically $1.0\text{ }\mu\text{F}$) from the output, V_O , to ground. When an external transistor is used to boost the current, $C_O = 1.0\text{ }\mu\text{F}$ is also recommended (see Figure 2).

FIGURE 28A – LOAD TRANSIENT RESPONSE

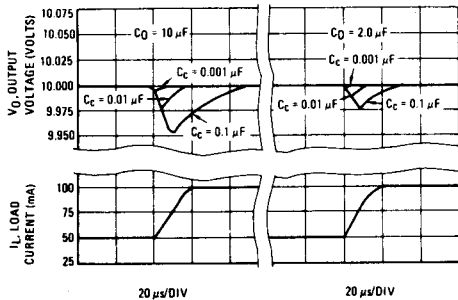
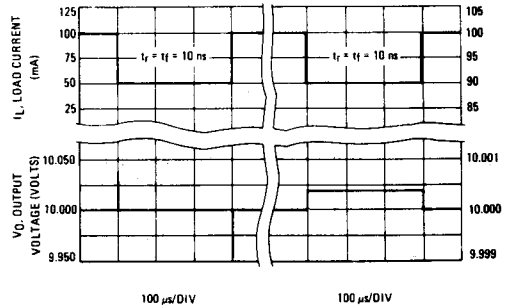
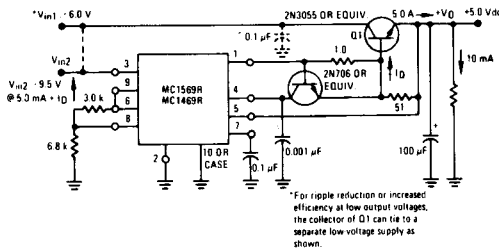

FIGURE 28B – LOAD TRANSIENT RESPONSE



TYPICAL NPN CURRENT BOOST CONNECTIONS
 查询"MC1469R"供应商
 FIGURE 29A - 5-VOLT 5-AMPERE REGULATOR



*For ripple reduction or increased efficiency at low output voltages, the collector of Q1 can tie to a separate low voltage supply as shown.

FIGURE 29B - 5-VOLT 5-AMPERE REGULATOR

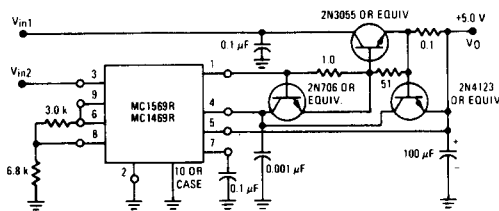
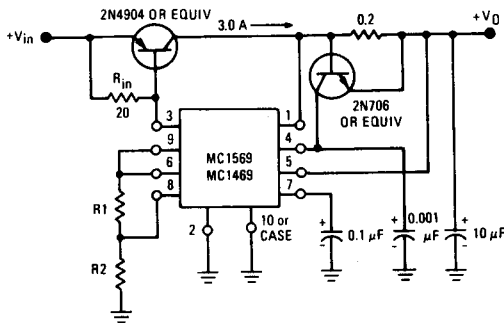

FIGURE 30 - PNP CURRENT BOOST CONNECTION



NPN CURRENT BOOSTING

For applications requiring more than 500 mA of load current, or for minimizing voltage variations due to temperature changes in the IC regulator arising from changes of the internal power dissipation, the NPN current-boost circuits of Figure 3 or 29 are recommended. The transistor shown in Figure 29A, the 2N3055 can supply currents to 5.0 amperes (subject, of course, to the safe area limitations). To improve the efficiency of the NPN

boost configuration, particularly for small output voltages, the circuit of Figure 29 is recommended. An auxiliary 9.5-volt supply is used to power the IC regulator and the heavy load current is obtained from a second supply of lower voltage. For the 5.0 ampere regulator of Figure 29 this represents a savings of 17.5 watts when compared with operating the regulator from the single 9.5 V supply. It can supply current to 5.0 amperes while requiring an input voltage to the collector of the pass transistor of 6.0 volts minimum. The pass transistor is limited to 5.0 amperes by the added short-circuit current network in its emitter (R_{SC}), (Figure 29B).

PNP CURRENT BOOSTING

A typical PNP current boost circuit is shown in Figure 30. Voltages from 2.5 Vdc to 37 Vdc and currents of many amperes can be obtained with this circuit.

Since the PNP transistor must not be turned on by the MC1569 bias current (I_{IB}) the resistor R_{in} must meet the following condition

$$R_{in} < \frac{V_{BE}}{I_{IB}}$$

where V_{BE} is the base-to-emitter voltage required to turn on the PNP pass transistor, (typically 0.6 Vdc for silicon and 0.2 Vdc for germanium).

For germanium pass transistors, a silicon diode may be placed in series with the emitter to provide an additional voltage drop. This allows a larger value of R_{in} than would be possible if the diode were omitted. The diode will, however, be required to carry the maximum load current.

SELF-OSCILLATING SWITCHING REGULATOR

In all of the current boosting circuits shown thus far it has been assumed that the input-output voltage differential can be minimized to obtain maximum efficiency in both the external pass element as well as the MC1569. This may not be possible in applications where only a single supply voltage is available and high current levels preclude zener diode pre-regulating approaches. In such applications a switching-mode voltage regulator is highly desirable since the pass device is either ON or OFF. The theoretical efficiency of an ideal switching regulator is 100%. Realizable efficiencies of 90% are within the realm of possibility thus obviating the need for large power dissipating components. The output voltage will contain a ripple component; however, this can be made quite small if the switching frequency is made relatively high so filtering techniques are effective. Figure 31 shows a functional diagram for a self-oscillating voltage regulator. The comparator-driver will sense the voltage across the inductor, this voltage being related to the load current, I_L , by

查询"MC1469"的供应商

For a first approximation this can be assumed to be a linear relationship.

Initially, V_O will be low and Q1 will be ON. The voltage at the non-inverting input will approach $\beta_1 V_{in}$, when:

$$\beta_1 V_{in} = \frac{V_{ref} R_a}{R_a + R_b} + \frac{V_c R_b}{R_a + R_b}$$

When this output voltage is reached the comparator will switch, turning Q1 OFF. The diode, CR1, will now become forward biased and will supply a path for the inductor current. This current and the sense voltage will start to decrease until the output voltage reaches

$$\beta_2 V_{in} = \frac{V_{ref} R_a}{R_a + R_b}$$

where the comparator will again switch turning Q1 ON, and the cycle repeats. Thus the output voltage is approximately V_{ref} plus a ripple component.

The frequency of oscillation can be shown to be

$$f = \frac{V_O (V_{in} - V_O)}{L V_C I(\max) - I_O} \quad (1)$$

where

$I(\max)$ = The maximum value of inductor current

I_O = The minimum inductor current.

Normally this frequency will be in the range of approximately 2 kHz to 6 kHz. In this range, inductor values can be small and are compatible with the switching times of the pass transistor and diode. The switching time of the comparator is quite fast since positive feedback aids both turn-on and turn-off times. The limiting factors are the diode and pass transistor rise and fall times which should be quite fast or efficiency will suffer.

Figure 32 shows a self oscillating switching regulator which in many respects is similar to the PNP current boost previously discussed. The 6.8 kΩ resistor in conjunction with R1 sets the reference voltage, V_{ref} . Q1 and CR1 are selected for fast switching times as well as the necessary power dissipation ratings. Since a linear inductor is assumed, the inductor cannot be allowed to saturate at maximum load currents and should be chosen accordingly. If core saturation does occur, peak transistor and diode currents will be large and power dissipation will increase.

FIGURE 31 – BASIC SELF-OSCILLATING SWITCHING REGULATOR

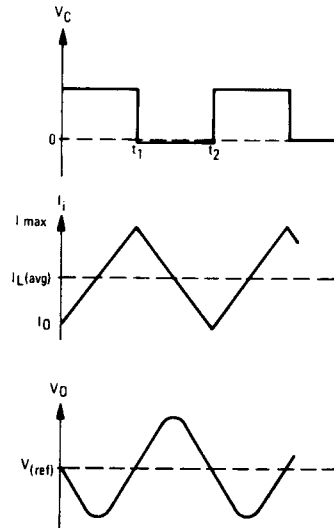
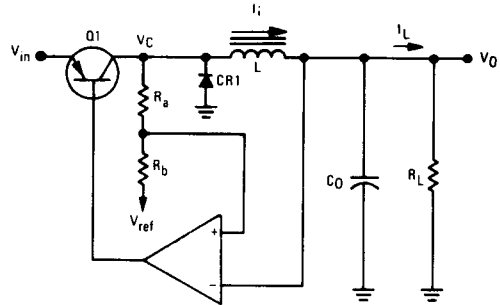
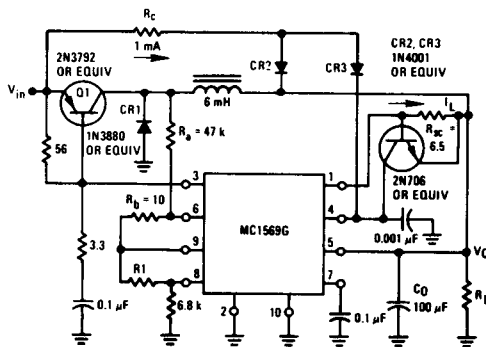

FIGURE 32 – MC1569 SELF-OSCILLATING SWITCHING REGULATOR



查询"MC1469"供应商

As a design center is required for a practical circuit, assume the following requirements:

$$V_{in} = +28 \text{ Volts}$$

$$V_O = +10 \text{ Volts}$$

$$\Delta V_O = 50 \text{ mV}$$

$$f \cong 5 \text{ kHz}$$

$$I(\text{max}) = 1.125 \text{ A}$$

$$I_O = 1 \text{ A}$$

$$\Delta V \approx V_{in} \frac{R_b}{R_a} \quad (2)$$

Using Equation (1), the inductor value can be found:

$$L = \frac{(28-10)}{2(1.125-1)} \frac{10}{28} \left(\frac{1}{5 \times 10^3} \right)$$

$$\approx 7 \text{ mH.}$$

For the test circuit, a value of 6 mH was selected. Using for a first approximation

$$C_O = \frac{(V_{in} - V_O)(V_O)}{8L f^2 V_{in} (\Delta V)}$$

$$= \frac{(28 - 10)10}{8(7 \times 10^{-3})(5 \times 10^3)^2 (28)(50 \times 10^{-3})}$$

$$\approx 95 \mu\text{F.}$$

As shown, a value of 100 μF was selected. Since little current is required at pin 6, R_a can be large. Assume $R_a = 47 \text{ k}\Omega$ and then use Equation (2) to determine R_b :

$$50 \times 10^{-3} = \frac{28}{47 \text{ k}\Omega} R_b$$

$$R_b = \frac{47}{28} 50 \approx 85\Omega.$$

Since the internal impedance presented by pin 9 is on the order of 60 Ω , a value of $R_b = 10\Omega$ is adequate.

Diodes CR2, CR3, and R_C may be added to prevent saturation of the error amplifier to increase switching

speed. When the output stage of the error amplifier approaches saturation, CR2 becomes forward biased and clamps the error amplifier. Resistor R_C should be selected to supply a total of 1 mAdc to CR2 and CR3.

To show correlation between the predicted and tested specifications the following data was obtained:

$$V_{in} = +28 (\pm 1\%) \text{ Volts}$$

$$V_O = +10 \text{ Volts}$$

$$\Delta V_O = 60 \text{ mV}$$

$$f = 7 \text{ kHz}$$

$$@ I_L = 1 \text{ A}$$

which checks quite well with the predicted values. R_b can be adjusted to minimize the ripple component as well as to trim the operating frequency. Also this frequency will change with varying loads as is normal with this type of circuit. Pin 2 can still be used for shut-down if so desired. R_{SC} should be set such that the ratio of load current to base drive current is 10:1 in this case $I_1 \approx 100 \text{ mA}$ and $R_{SC} = 6.5\Omega$.

POSITIVE AND NEGATIVE POWER SUPPLIES

If the MC1569 is driven from a floating source it is possible to use it as a negative regulator by grounding the positive output terminal. The MC1569 may also be used with the MC1563 to provide completely independent positive and negative voltage regulators with comparable performance.

Some applications may require complementary tracking in which both supplies arrive at the voltage level simultaneously, and variations in the magnitudes of the two voltages track. Figures 1 and 33 illustrate this approach. In this application, the MC1563 is used as the reference regulator, establishing the negative output voltage. The MC1569 positive regulator is used in a tracking mode by grounding one side of the differential amplifier (pin 6 of the MC1569) and using the other side (pin 5 of the MC1569) to sense the voltage developed at the junction of the two 3-k ohm resistors. This differential amplifier controls the MC1569 series pass transistor such that the voltage at pin 5 will be zero. When the voltage at pin 5 equals zero, $+V_O$ must equal $-V_O$.

For the configuration shown in Figure 33, the level shift amplifier in the MC1569 is employed to generate an auxiliary +5-volt supply which is boosted to a 2-ampere capability by Q1 and Q2. (The +5-volt supply, as shown,

is shown in Figure 33. The -15 -volt supply varies less than 0.1 mV over a zero to -300 mA dc current range and the $+15$ -volt supply tracks this variation. The $+15$ -volt supply varies 20 mV over the zero to $+300$ mA dc load current range. The $+5$ -volt supply varies less than 5 mV for $0 \leq I_L \leq 200$ mA with the other two voltages remaining unchanged. See page 19 for additional information.

SHUTDOWN TECHNIQUES

Pin 2 of the MC1569 is provided for the express purpose of shutting the regulator "OFF". Referring to the schematic, it can be seen that pin 2 goes to the base of an NPN transistor; which, if turned "ON", will turn the zener "OFF" and deny current to all the biasing current sources. This action causes the output to go to essentially

zero volts and the only current drawn by the IC regulator will be the small start current through the 60 -k-ohm start resistor ($V_{in}/60$ k Ω). This feature provides additional versatility in the applications of the MC1569. Various subsystems may be placed in a "standby" mode to conserve power until actually needed. Or the power may be turned "OFF" in response to other occurrences such as overheating, over-voltage, shorted output, etc.

To activate shutdown, one simply applies a potential greater than two diode drops with a current capability of 1 mA. Note that if a hard supply (i.e., $+3$ V) is applied directly to pin 2, the shutdown circuitry will be destroyed since there is no inherent current limiting. Maximum rating for the drive current into pin 2 is 10 mA, while 1 mA is adequate for shutdown.

FIGURE 33 - A ± 15 Vdc COMPLEMENTARY TRACKING REGULATOR WITH AUXILIARY $+5.0$ V SUPPLY

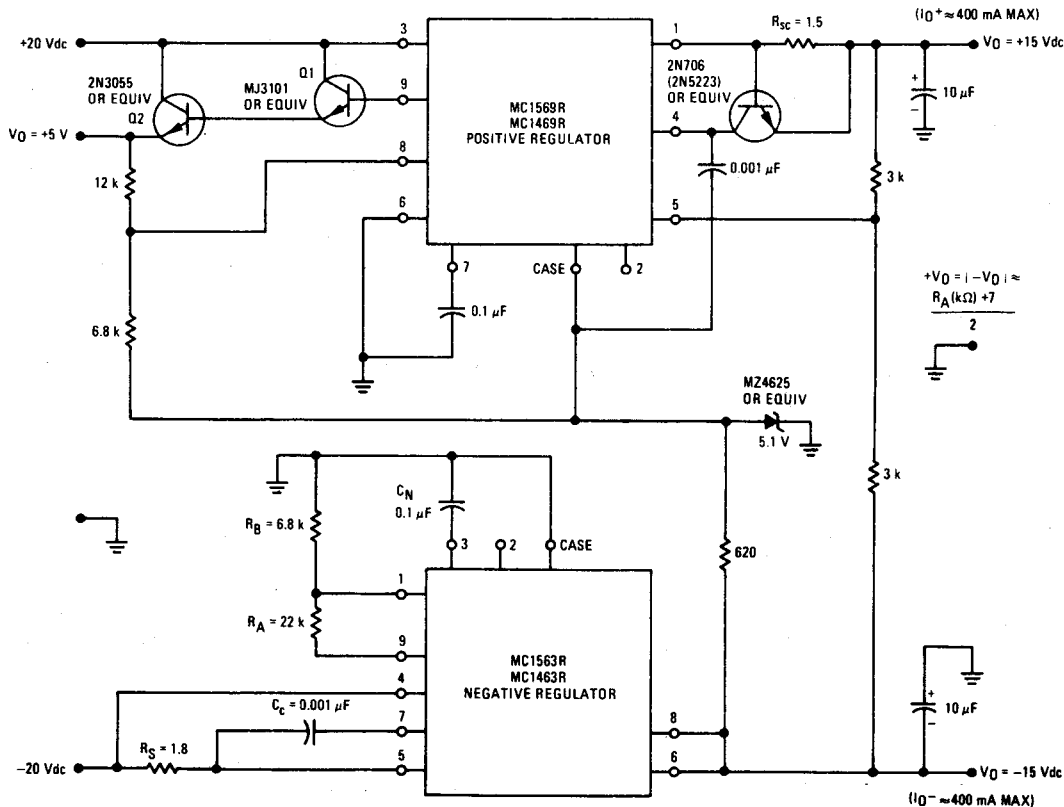

FIGURE 34 - ELECTRONIC SHUT-DOWN USING A MDTL GATE

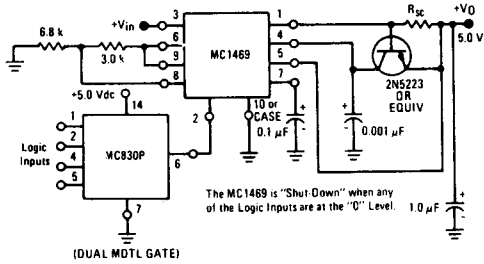

FIGURE 35 - AUTOMATIC LATCH INTO SHUT-DOWN WHEN OUTPUT IS SHORT-CIRCUITED WITH MANUAL RE-START

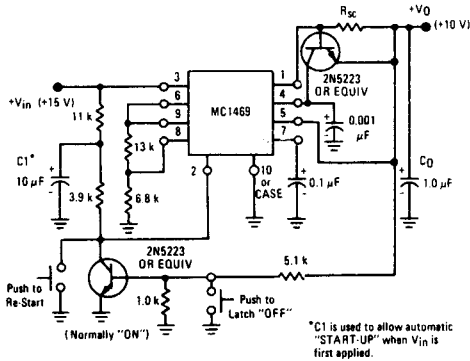

FIGURE 36 - VOLTAGE BOOSTING CIRCUIT

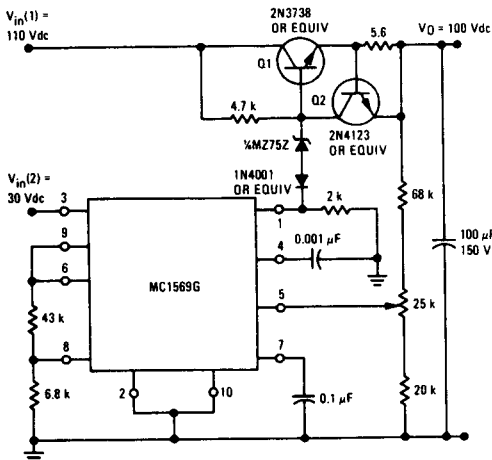

Figure 34 shows how the regulator can be controlled by a logic gate. Here, it is assumed that the regulator operates in its normal mode — as a positive regulator referenced to ground — and that the logic gate is of the saturating type, operating from a positive supply to ground. The high logic level should be greater than about 1.5 V and should source no more than 10 mA into pin 2.

The gate shown is of the MDTL type. MRTTL and MTTL can also be used as long as the drive current is within safe limits (this is important when using MTTL, where the output stage uses an active pull-up).

In some cases a regulator can be designed which can handle the power dissipation resulting from normal operation but cannot safely dissipate the power resulting from a sustained short-circuit. The circuit of Figure 35 solves this problem by shutting down the regulator when the output is short-circuited.

VOLTAGE BOOSTING

The MC1569 has a maximum output voltage capability of 37 volts which covers the bulk of the user requirements. However, it is possible to obtain higher output voltages. One such voltage boosting circuit is shown in Figure 36.

Since high voltage NPN silicon devices are readily available, the only problem is the voltage limitations of the MC1569. This can be overcome by using voltage shift techniques to limit the voltage to 35 volts across the MC1569 while referencing to a higher output voltage.

The zener diode in the base lead of the NPN device is used to shift the output voltage of the MC1569 by approximately 75 volts to the desired high voltage level, in this case 100 volts. Another voltage shift is accomplished by the resistor divider on the output to accommodate the required 25 volt reference to the MC1569. The 2 kΩ resistor is used to bias the zener diode so the current through the 4.7 kΩ resistor can be controlled by the MC1569. The 1N4001 diode protects the MC1569 from supplying load current under short circuit conditions and Q2 serves to limit base current to Q1. For R_{sc} as shown, the short circuit current will be approximately 100 mA.

In order to use a single supply voltage, $V_{in}(2)$ can be derived from $V_{in}(1)$ with a zener diode, shunt pre-regulator.

It can be seen that loop gain has been reduced by the resistor divider and hence the closed loop bandwidth will be less. This of course will result in a more stable system, but regulator performance is degraded to some degree.

REMOTE SENSING

The MC1569 offers a remote sensing capability. This is important when the load is remote from the regulator,

as the resistance of the interconnecting lines (V_O and GND) is added directly to the output impedance of the regulator. By remote sensing, this resistance is included inside the control loop of the regulator and is essentially eliminated. Figure 37 shows how remote sensing is accomplished using both a separate sense line from pin 8 and a separate ground line from the regulator to the remote load.

AN ADJUSTABLE ZERO-TEMPERATURE-COEFFICIENT (0-TC) VOLTAGE REFERENCE SOURCE.

The MC1569, when used in conjunction with low TC resistors, makes an excellent reference-voltage generator. If the 3.5 volt reference voltage of the IC regulator is a satisfactory value, then pins 8 and 9 can be tied together and no resistors are needed. This will provide a voltage

reference having a typical temperature coefficient of 0.002%/°C. By adding two resistors, R1 and R2, any voltage between 3.5 Vdc and 37 Vdc can be obtained with the same low TC (see Figure 38).

THERMAL SHUTDOWN

By setting a fixed voltage at pin 2, the MC1569 chip can be protected against excessive junction temperatures caused by power dissipation in the IC regulator. This is based on the negative temperature coefficient of the base-emitter junction of the shutdown transistor and the diode in series with pin 2 ($-3.4 \times 10^{-3}V/°C$). By setting 1.0 Vdc externally at pin 2, the regulator will shutdown when the chip temperature reaches approximately +140°C. Figure 39 shows a circuit that uses a zero-TC zener diode and a resistive divider to obtain this voltage.

FIGURE 37 – REMOTE SENSING CIRCUIT

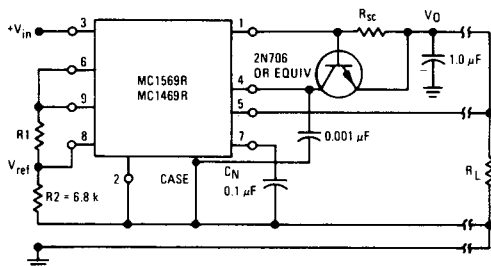
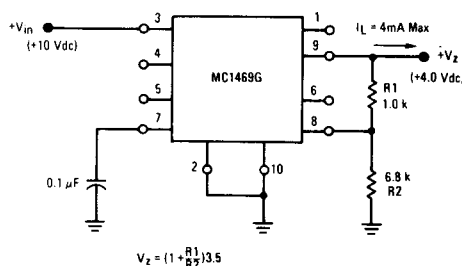

FIGURE 38 – AN ADJUSTABLE “ZERO-TC” VOLTAGE SOURCE



$$V_z = (1 + \frac{R_1}{R_2}) 3.5$$

FIGURE 39 – JUNCTION TEMPERATURE LIMITING SHUTDOWN CIRCUIT

FIGURE 39A – USING A ZERO TC REFERENCE

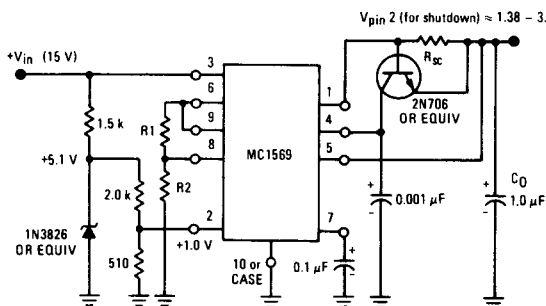

FIGURE 39B – USING A T_A REFERENCE

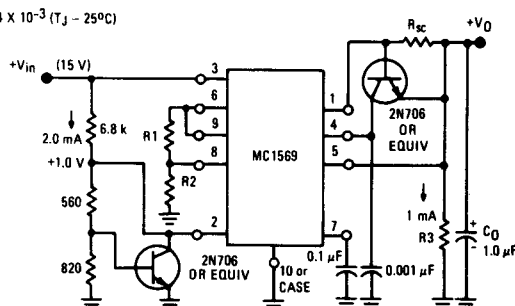
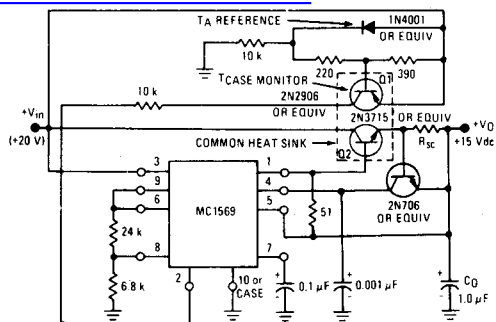

FIGURE 40 — THERMAL SHUTDOWN WHEN USING EXTERNAL PASS TRANSISTORS



4

In the case where an external pass transistor is employed, its temperature, rather than that of the IC regulator, requires control. A technique similar to the one just discussed can be used by directly monitoring the case temperature of the pass transistor as is indicated in Figure 40. The case of the normally "OFF" thermal monitoring transistor, Q2, should be in thermal contact with, but electrically isolated from, the case of the boost transistor, Q1.

THERMAL CONSIDERATIONS

Monolithic voltage regulators are subjected to internal heating similar to a power transistor. Since the degree of internal heating is a function of the specific application, the designer must use caution not to exceed the specified maximum junction temperature (+150°C). Exceeding this limit will reduce reliability at an exponential rate. Good heatsinking not only reduces the junction temperature for a given power dissipation; it also tends to improve the dc stability of the output voltage by reducing the junction temperature change resulting from a change in the power dissipation of the IC regulator. By using the derating factors or thermal resistance values given in the Maximum Ratings Table of this data sheet, junction temperature can be computed for any given application in the same manner as for a power transistor*. A short-circuit on the output terminal can produce a "worst-case" thermal condition especially if the maximum input voltage is applied simultaneously with the maximum value of short-circuit load current. Care should be taken not to

*For more detailed information of methods used to compute junction temperature, see Motorola Application Note AN-226, Measurement of Thermal Properties of Semiconductors.

FIGURE 41 — DC SAFE OPERATING AREA

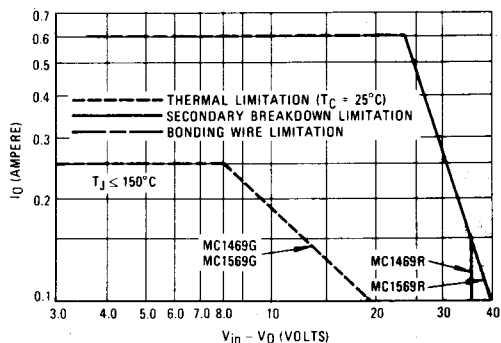

exceed the maximum junction temperature rating during this fault condition and, in addition, the dc safe operating area limit (see Figure 41).

Thermal characteristics for a voltage regulator are useful in predicting performance since dc load and line regulation are affected by changes in junction temperature. These temperature changes can result from either a change in the ambient temperature, TA, or a change in the power dissipated in the IC regulator. The effects of ambient temperature change on the dc output voltage can be estimated from the "Temperature Coefficient of Output Voltage" characteristic parameter shown as ±0.002%/°C, typical. Power dissipation is typically changed in the IC regulator by varying the dc load current. To estimate the dc change in output voltage due to a change in the dc load current, three effects must be considered:

1. junction temperature change due to the change in the power dissipation
2. output voltage decrease due to the finite output impedance of the control amplifier
3. thermal gradient on the IC chip.

A temperature differential does exist across a power IC chip and can cause a dc shift in the output voltage. A "gradient coefficient," GCV0, can be used to describe this effect and is typically -0.06%/watt for the MC1569. For an example of the relative magnitudes of these effects, consider the following conditions:

Given MC1569
 with $V_{in} = 10 \text{ Vdc}$
 $V_0 = 5 \text{ Vdc}$

查询"MC1469"供应商

$(\Delta I_L = 100 \text{ mA})$

assume $T_A = +25^\circ\text{C}$

TO-66 Case with heatsink

assume $\theta_{CS} = 0.2^\circ\text{C/W}$

and $\theta_{SA} = 2^\circ\text{C/W}$

$\theta_{JC} = 7.15^\circ\text{C/W}$ (from maximum ratings table)

It is desired to find the ΔV_O which results from this ΔI_L . Each of the three previously stated effects on V_O can now be separately considered.

1. ΔV_O due to ΔT_J

$\Delta V_O = (V_O)(\Delta P_D)(TCV_O)(\theta_{JC} + \theta_{CS} + \theta_{SA})$

OR

$\Delta V_O = (5V)(5 \text{ V} \times 0.1A)(\pm 0.002\%/^\circ\text{C})(9.35^\circ\text{C/W})$

$\Delta V_O \approx \pm 0.5 \text{ mV}$

2. ΔV_O due to z_o

$|\Delta V_O| = (-z_o)(\Delta I_L)$

$|\Delta V_O| = -(2 \times 10^{-2})(10^{-1}) = -2 \text{ mV}$

3. ΔV_O due to gradient coefficient, GCV_O

$|\Delta V_O| = (GCV_O)(V_O)(\Delta P_D)$

$|\Delta V_O| = (-6 \times 10^{-4}/\text{W})(5 \text{ volts})(5 \times 10^{-1}\text{W})$

$|\Delta V_O| = -1.6 \text{ mV}$

Therefore the total ΔV_O is given by

$|\Delta V_O \text{ total}| = \pm 0.5 - 2.0 - 1.6 \text{ mV}$

OR

$-4.1 \text{ mV} \leq |V_O \text{ total}| \leq -3.1 \text{ mV}$

Other operating conditions may be substituted and computed in a similar manner to evaluate the relative effects of the parameters.

TYPICAL PRINTED CIRCUIT BOARD LAYOUT

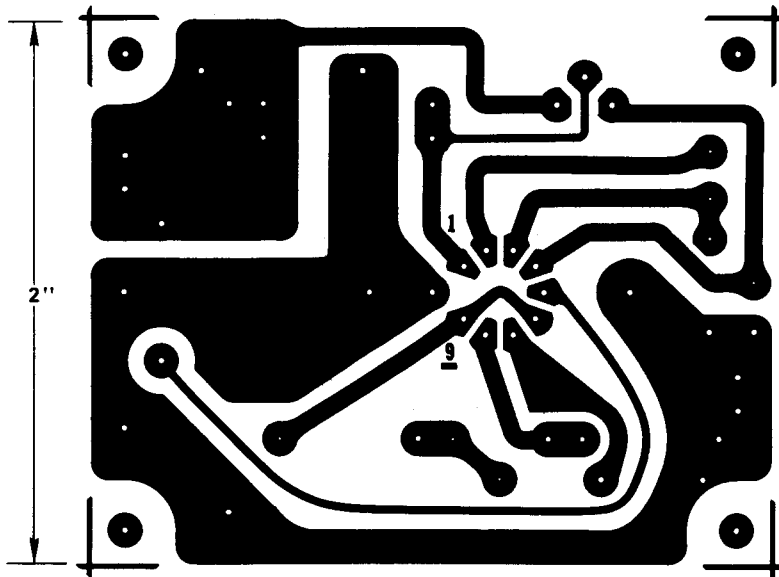

查询"MC1469R"供应商

4

FIGURE 42 – LOCATION OF COMPONENTS

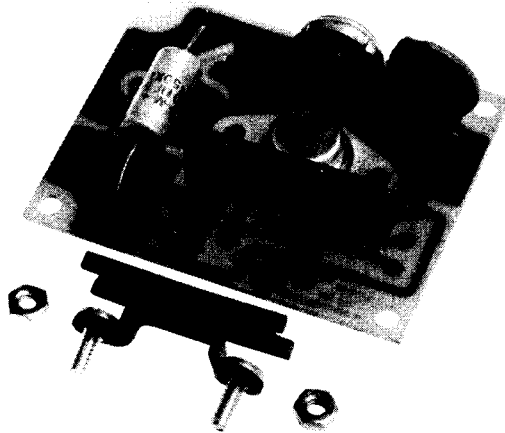
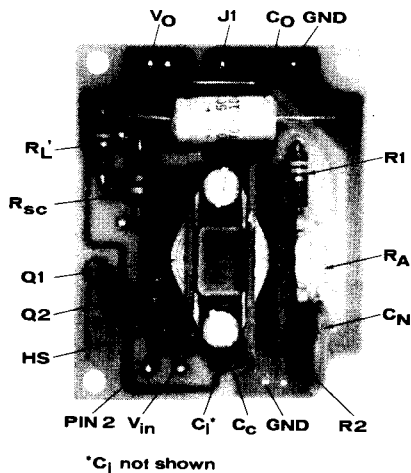
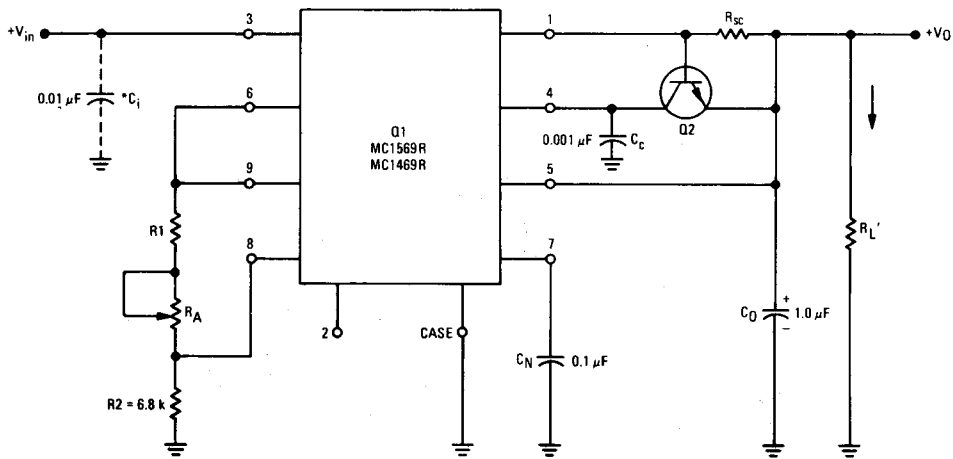

FIGURE 43 – CIRCUIT SCHEMATIC FOR PRINTED CIRCUIT BOARD (Pg. 17)
 $3.5 \text{ V} \leq V_O \leq 37 \text{ V}$, $1 \text{ mA} \leq I_L \leq 500 \text{ mA}$



Select R1 to give desired V_O: $R1 \approx (2 V_O - 7) \text{ k}\Omega$

*C_j – May be required if long input leads are used.

查询"MC1469R"供应商

PARTS LIST

Component	Value	Description
R1	Select	1/4 or 1/2 watt carbon
R2	6.8 k	
*R _A	Select	IRC Model X-201 Mallory Model MTC-1 or equivalent
R _{sc}	Select	1/2 watt carbon
*R _L	Select	For minimum current of 1 mA _{dc}
C _O	1.0 μF	Sprague 1500 Series, Dickson D10C series or equivalent
C _N	0.1 μF } 0.001 μF } 0.01 μF }	Ceramic Disc – Centralab DDA 104, Sprague TG-P10, or equivalent
C _c		
*C _i		
Q1	MC1569R or MC1469R	Heatsink Thermalloy #6168B
Q2	2N5223, 2N706, or equivalent	
*HS	—	Robinson Nugent #0001306
*Socket	(Not Shown)	Electronic Molding Corp. #6341-210-1, 6348-188-1, 6349-188-1
PC Board	—	Circuit Dot, Inc. #PC1113
*Optional		1155 W. 23rd St., Tempe, Ariz. 85281

4

LATCH-UP

Latch-up of these and other regulators can occur if:

1. There are plus and minus voltages available
2. A load exists between V_O⁺ and V_O⁻ (This "common load" may be something inconspicuous – e.g. an operational amplifier. Nearly everyone who uses + and – voltages will have a common load from V_{CC} to V_{EE}.)
3. V_{in}⁺ and V_{in}⁻ are not applied at the same time.

The above conditions result in one of the two outputs becoming reverse-biased which prevents the regulator from turning ON. Latch-up can be prevented by the circuit configurations shown in Figures 44 and 45.

FIGURE – 44

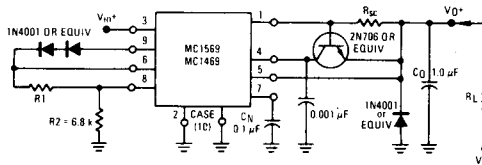

Note: This configuration increases minimum input-output differential voltage by ~ 0.7 V.

FIGURE – 45

