

查询"5962-9758401Q2A"供应商																		REVISIONS																	
LTR			DESCRIPTION												DATE(YR-MO-DA)			APPROVED																	
A			Add vendor cage 27014 for device 01. Technical changes in 1.3. - tdn												97-07-18			Raymond Monnin																	
REV																																			
SHEET																																			
REV																																			
SHEET																																			
REV STATUS OF SHEETS			REV		A	A	A	A	A	A	A	A	A	A	A	A	A																		
			SHEET		1	2	3	4	5	6	7	8	9	10	11	12	13																		
PMIC N/A			PREPARED BY Tuan Nguyen						<b>DEFENSE SUPPLY CENTER COLUMBUS COLUMBUS, OHIO 43216</b>																										
<b>STANDARD MICROCIRCUIT DRAWING</b>			CHECKED BY Larry Shaw						<b>MICROCIRCUIT, DIGITAL, BIPOLAR, ADVANCED SCHOTTKY TTL, DUAL 4-INPUT POSITIVE-NAND GATE, MONOLITHIC SILICON</b>																										
THIS DRAWING IS AVAILABLE FOR USE BY ALL DEPARTMENTS  AND AGENCIES OF THE DEPARTMENT OF DEFENSE			APPROVED BY Raymond Monnin																																
			DRAWING APPROVAL DATE 97-05-30																																
AMSC N/A			REVISION LEVEL						SIZE A		CAGE CODE 67268		<b>5962-97584</b>																						
									SHEET		1 OF 13																								

DSCC FORM 2233  
APR 97

5962-E252-97

DISTRIBUTION STATEMENT A: Approved for public release; distribution is unlimited.

■ 9004708 0029821 505 ■

1. SCOPE

1.1 Scope. This drawing documents two product assurance class levels consisting of high reliability (device classes Q and M) and space application (device class V). A choice of case outlines and lead finishes are available and are reflected in the Part or Identifying Number (PIN). When available, a choice of Radiation Hardness Assurance (RHA) levels are reflected in the PIN.

1.2 PIN. The PIN is as shown in the following example:

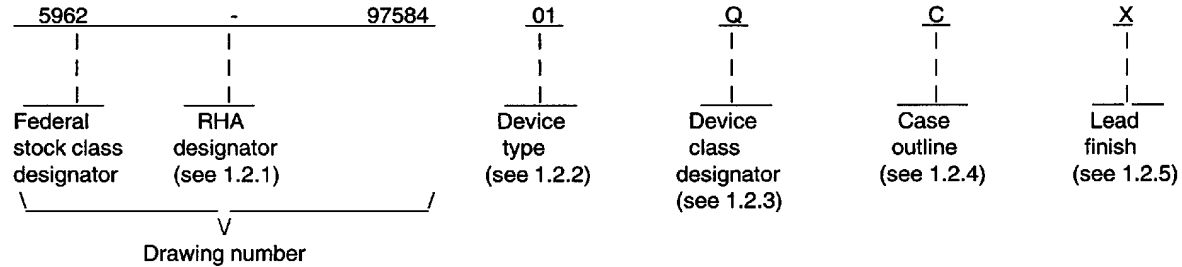

1.2.1 RHA designator. Device classes Q and V RHA marked devices meet the MIL-PRF-38535 specified RHA levels and are marked with the appropriate RHA designator. Device class M RHA marked devices meet the MIL-PRF-38535, appendix A specified RHA levels and are marked with the appropriate RHA designator. A dash (-) indicates a non-RHA device.

1.2.2 Device type(s). The device type(s) identify the circuit function as follows:

<u>Device type</u>	<u>Generic number</u>	<u>Circuit function</u>
01	54F20	Dual 4-input positive-nand gate

1.2.3 Device class designator. The device class designator is a single letter identifying the product assurance level as follows:

<u>Device class</u>	<u>Device requirements documentation</u>
M	Vendor self-certification to the requirements for MIL-STD-883 compliant, non-JAN class level B microcircuits in accordance with MIL-PRF-38535, appendix A
Q or V	Certification and qualification to MIL-PRF-38535

1.2.4 Case outline(s). The case outline(s) are as designated in MIL-STD-1835 and as follows:

<u>Outline letter</u>	<u>Descriptive designator</u>	<u>Terminals</u>	<u>Package style</u>
C	GDIP1-T14 or CDIP2-T14	14	dual-in-line
D	GDFP1-F14 or CDFP2-F14	14	flat pack
2	CQCC1-N20	20	leadless square chip carrier

1.2.5 Lead finish. The lead finish is as specified in MIL-PRF-38535 for device classes Q and V or MIL-PRF-38535, appendix A for device class M.

<b>STANDARD MICROCIRCUIT DRAWING</b>	<b>SIZE A</b>		<b>5962-97584</b>
<b>DEFENSE SUPPLY CENTER COLUMBUS COLUMBUS, OHIO 43216-5000</b>		REVISION LEVEL <b>A</b>	SHEET <b>2</b>

1.3 Absolute maximum ratings. 1/

Supply voltage range (V <sub>CC</sub> ) .....	-0.5V dc to +7.0 V dc
Input voltage (V <sub>IN</sub> ).....	-1.2 V at -18 mA to +7.0 V dc
Input current range (I <sub>I</sub> ) .....	-30 mA to 5 mA
Voltage range applied to any output in the high state .....	-0.5 V to V <sub>CC</sub>
Current into any output in the low state .....	40mA
Maximum power dissipation (P <sub>D</sub> ).....	80mW
Operating free air temperature range.....	-55 °C to +125 °C
Storage temperature range .....	-65 °C to +150 °C
Thermal resistance, junction-to-case (θ <sub>JC</sub> ).....	See MIL-STD-1835
Junction temperature (T <sub>J</sub> ) .....	+175 °C

1.4 Recommended operating conditions.

Supply voltage range (V <sub>CC</sub> ).....	4.5 V dc to 5.5 V dc
High-level input voltage (V <sub>IH</sub> ) .....	2V min
Low-level input voltage (V <sub>IL</sub> ) .....	0.8 V min
Input clamp current (I <sub>IK</sub> ) .....	-18 mA max
High-level output current (I <sub>OH</sub> ).....	-1mA max
Low-level output current (I <sub>OL</sub> ) .....	20mA max
Case operating temperature range (T <sub>C</sub> ).....	-55 °C to +125 °C

1.5 Digital logic testing for device classes Q and V.

Fault coverage measurement of manufacturing logic tests (MIL-STD-883, test method 5012).....XXpercent 2/

2. APPLICABLE DOCUMENTS

2.1 Government specification, standards, and handbooks. The following specification, standards, and handbooks form a part of this drawing to the extent specified herein. Unless otherwise specified, the issues of these documents are those listed in the issue of the Department of Defense Index of Specifications and Standards (DoDISS) and supplement thereto, cited in the solicitation.

SPECIFICATION

MILITARY

MIL-PRF-38535 - Integrated Circuits, Manufacturing, General Specification for.

1/ Stresses above the absolute maximum rating may cause permanent damage to the device. Extended operation at the maximum levels may degrade performance and affect reliability.  
 2/ Values will be added when they become available.

<b>STANDARD MICROCIRCUIT DRAWING</b>  <b>DEFENSE SUPPLY CENTER COLUMBUS COLUMBUS, OHIO 43216-5000</b>	SIZE <b>A</b>		<b>5962-97584</b>
		REVISION LEVEL <b>A</b>	SHEET <b>3</b>

MILITARY

- MIL-STD-883 - Test Methods and Procedures for Microelectronics.
- MIL-STD-973 - Configuration Management.
- MIL-STD-1835 - Microcircuit Case Outlines.

HANDBOOKS

MILITARY

- MIL-HDBK-103 - List of Standard Microcircuit Drawings (SMD's).
- MIL-HDBK-780 - Standard Microcircuit Drawings.

(Unless otherwise indicated, copies of the specification, standards, and handbooks are available from the Standardization Document Order Desk, 700 Robbins Avenue, Building 4D, Philadelphia, PA 19111-5094.)

2.2 Order of precedence. In the event of a conflict between the text of this drawing and the references cited herein, the text of this drawing takes precedence. Nothing in this document, however, supersedes applicable laws and regulations unless a specific exemption has been obtained.

3. REQUIREMENTS

3.1 Item requirements. The individual item requirements for device classes Q and V shall be in accordance with MIL-PRF-38535 and as specified herein or as modified in the device manufacturer's Quality Management (QM) plan. The modification in the QM plan shall not affect the form, fit, or function as described herein. The individual item requirements for device class M shall be in accordance with MIL-PRF-38535, appendix A for non-JAN class level B devices and as specified herein.

3.2 Design, construction, and physical dimensions. The design, construction, and physical dimensions shall be as specified in MIL-PRF-38535 and herein for device classes Q and V or MIL-PRF-38535, appendix A and herein for device class M.

3.2.1 Case outline. The case outline shall be in accordance with 1.2.4 herein .

3.2.2 Terminal connections. The terminal connections shall be as specified on figure 1.

3.2.3 Truth table. The truth table shall be as specified on figure 2.

3.2.4 Logic diagram. The logic diagram shall be as specified on figure 3.

3.2.5 Switching waveforms and test circuit. The switching waveforms and test circuit shall be as specified on figure 4.

3.3 Electrical performance characteristics and postirradiation parameter limits. Unless otherwise specified herein, the electrical performance characteristics and postirradiation parameter limits are as specified in table I and shall apply over the full case operating temperature range.

3.4 Electrical test requirements. The electrical test requirements shall be the subgroups specified in table II. The electrical tests for each subgroup are defined in table I.

3.5 Marking. The part shall be marked with the PIN listed in 1.2 herein. In addition, the manufacturer's PIN may also be marked as listed in MIL-HDBK-103. For packages where marking of the entire SMD PIN number is not feasible due to space limitations, the manufacturer has the option of not marking the "5962-" on the device. For RHA product using this option, the RHA designator shall still be marked. Marking for device classes Q and V shall be in accordance with MIL-PRF-38535. Marking for device class M shall be in accordance with MIL-PRF-38535, appendix A.

<b>STANDARD MICROCIRCUIT DRAWING</b>  <b>DEFENSE SUPPLY CENTER COLUMBUS COLUMBUS, OHIO 43216-5000</b>	<b>SIZE A</b>		<b>5962-97584</b>
		<b>REVISION LEVEL A</b>	<b>SHEET 4</b>

3.5.1 Certification/compliance mark. The certification mark for device classes Q and V shall be a "QML" or "Q" as required in MIL-PRF-38535. The compliance mark for device class M shall be a "C" as required in MIL-PRF-38535, appendix A.

3.6 Certificate of compliance. For device classes Q and V, a certificate of compliance shall be required from a QML-38535 listed manufacturer in order to supply to the requirements of this drawing (see 6.6.1 herein). For device class M, a certificate of compliance shall be required from a manufacturer in order to be listed as an approved source of supply in MIL-HDBK-103 (see 6.6.2 herein). The certificate of compliance submitted to DSCC-VA prior to listing as an approved source of supply for this drawing shall affirm that the manufacturer's product meets, for device classes Q and V, the requirements of MIL-PRF-38535 and herein or for device class M, the requirements of MIL-PRF-38535, appendix A and herein.

3.7 Certificate of conformance. A certificate of conformance as required for device classes Q and V in MIL-PRF-38535 or for device class M in MIL-PRF-38535, appendix A shall be provided with each lot of microcircuits delivered to this drawing.

3.8 Notification of change for device class M. For device class M, notification to DSCC-VA of change of product (see 6.2 herein) involving devices acquired to this drawing is required for any change as defined in MIL-STD-973.

3.9 Verification and review for device class M. For device class M, DSCC, DSCC's agent, and the acquiring activity retain the option to review the manufacturer's facility and applicable required documentation. Offshore documentation shall be made available onshore at the option of the reviewer.

3.10 Microcircuit group assignment for device class M. Device class M devices covered by this drawing shall be in microcircuit group number 8 (see MIL-PRF-38535, appendix A).

4. QUALITY ASSURANCE PROVISIONS

4.1 Sampling and inspection. For device classes Q and V, sampling and inspection procedures shall be in accordance with MIL-PRF-38535 or as modified in the device manufacturer's Quality Management (QM) plan. The modification in the QM plan shall not affect the form, fit, or function as described herein. For device class M, sampling and inspection procedures shall be in accordance with MIL-PRF-38535, appendix A.

4.2 Screening. For device classes Q and V, screening shall be in accordance with MIL-PRF-38535, and shall be conducted on all devices prior to qualification and technology conformance inspection. For device class M, screening shall be in accordance with method 5004 of MIL-STD-883, and shall be conducted on all devices prior to quality conformance inspection.

4.2.1 Additional criteria for device class M.

- a. Burn-in test, method 1015 of MIL-STD-883.
  - (1) Test condition A, B, C or D. The test circuit shall be maintained by the manufacturer under document revision level control and shall be made available to the preparing or acquiring activity upon request. The test circuit shall specify the inputs, outputs, biases, and power dissipation, as applicable, in accordance with the intent specified in test method 1015.
  - (2)  $T_A = +125\text{ }^\circ\text{C}$ , minimum.
- b. Interim and final electrical test parameters shall be as specified in table II herein.

<b>STANDARD MICROCIRCUIT DRAWING</b>  <b>DEFENSE SUPPLY CENTER COLUMBUS COLUMBUS, OHIO 43216-5000</b>	<b>SIZE A</b>		<b>5962-97584</b>
		<b>REVISION LEVEL A</b>	<b>SHEET 5</b>

TABLE I. Electrical performance characteristics.

Test	Symbol	Test Conditions -55°C ≤ T <sub>c</sub> ≤ +125°C unless otherwise specified	Group A subgroups	Limits		Unit
				Min	Max	
Input clamp voltage	V <sub>IK</sub>	V <sub>CC</sub> = 4.5 V, I <sub>I</sub> = -18 mA	1, 2, 3		-1.2	
High level output voltage	V <sub>OH</sub>	V <sub>CC</sub> = 4.5 V, I <sub>OH</sub> = -1 mA	1, 2, 3	2.5		V
Low-level output voltage	V <sub>OL</sub>	V <sub>CC</sub> = 4.5 V, I <sub>OL</sub> = 20 mA	1, 2, 3		0.5	V
Input current at maximum input voltage	I <sub>I</sub>	V <sub>CC</sub> = 5.5 V, V <sub>I</sub> = 7 V	1, 2, 3		0.1	mA
High-level input current	I <sub>IH</sub>	V <sub>CC</sub> = 5.5 V, V <sub>I</sub> = 2.7 V	1, 2, 3		20	μA
Low-level input current	I <sub>IL</sub>	V <sub>CC</sub> = 5.5 V, V <sub>I</sub> = 0.5 V	1, 2, 3		-0.6	mA
Short-circuit output current	I <sub>OS</sub> 1/	V <sub>CC</sub> = 5.5 V, V <sub>O</sub> = 0	1, 2, 3	-60	-150	mA
Supply current	I <sub>CCH</sub>	V <sub>CC</sub> = 5.5 V, V <sub>I</sub> = 0	1, 2, 3		1.4	mA
	I <sub>CCL</sub>	V <sub>CC</sub> = 5.5 V, V <sub>I</sub> = 4.5 V	1, 2, 3		5.1	
Functional test		V <sub>IN</sub> = V <sub>IH</sub> Min or V <sub>IL</sub> Max, Verify output V <sub>O</sub> , See 4.4.1b	7, 8			

See footnotes at end of table.

<b>STANDARD MICROCIRCUIT DRAWING</b>  <b>DEFENSE SUPPLY CENTER COLUMBUS</b> <b>COLUMBUS, OHIO 43216-5000</b>	<b>SIZE A</b>		<b>5962-97584</b>
		<b>REVISION LEVEL A</b>	<b>SHEET 6</b>

TABLE I. Electrical performance characteristics.

Test	Symbol	Conditions -55°C ≤ T <sub>C</sub> ≤ +125°C unless otherwise specified	Group A subgroups	Limits		Unit
				Min	Max	
Propagation delay time, low-to-high level Y output from A, B, C, or D input	t <sub>PLH</sub>	See figure 4 2/ 3/	9	1.6	5	ns
			10, 11	1.2	7	
Propagation delay time, high-to-low level Y output from A, B, C, or D input	t <sub>PHL</sub>		9	1	4.3	ns
			10, 11	1	6.5	

1/ Not more than one output should be shorted at a time, and the duration of the short circuit should not exceed one second.

2/ For group A subgroup 9, V<sub>CC</sub> = 5.0 V, C<sub>L</sub> = 50 pF, R<sub>L</sub> = 500 Ω

3/ For group A subgroups 10 and 11, V<sub>CC</sub> = 4.5 V to 5.5 V, C<sub>L</sub> = 50 pF, R<sub>L</sub> = 500 Ω

4.2.2 Additional criteria for device classes Q and V.

- a. The burn-in test duration, test condition and test temperature, or approved alternatives shall be as specified in the device manufacturer's QM plan in accordance with MIL-PRF-38535. The burn-in test circuit shall be maintained under document revision level control of the device manufacturer's Technology Review Board (TRB) in accordance with MIL-PRF-38535 and shall be made available to the acquiring or preparing activity upon request. The test circuit shall specify the inputs, outputs, biases, and power dissipation, as applicable, in accordance with the intent specified in test method 1015 of MIL-STD-883.
- b. Interim and final electrical test parameters shall be as specified in table II herein.
- c. Additional screening for device class V beyond the requirements of device class Q shall be as specified in MIL-PRF-38535, appendix B.

4.3 Qualification inspection for device classes Q and V. Qualification inspection for device classes Q and V shall be in accordance with MIL-PRF-38535. Inspections to be performed shall be those specified in MIL-PRF-38535 and herein for groups A, B, C, D, and E inspections (see 4.4.1 through 4.4.4).

4.4 Conformance inspection. Technology conformance inspection for classes Q and V shall be in accordance with MIL-PRF-38535 including groups A, B, C, D, and E inspections and as specified herein except where option 2 of MIL-PRF-38535 permits alternate in-line control testing. Quality conformance inspection for device class M shall be in accordance with MIL-PRF-38535, appendix A and as specified herein. Inspections to be performed for device class M shall be those specified in method 5005 of MIL-STD-883 and herein for groups A, B, C, D, and E inspections (see 4.4.1 through 4.4.4).

<b>STANDARD MICROCIRCUIT DRAWING</b>  <b>DEFENSE SUPPLY CENTER COLUMBUS COLUMBUS, OHIO 43216-5000</b>	<b>SIZE A</b>		<b>5962-97584</b>
		<b>REVISION LEVEL A</b>	<b>SHEET 7</b>

Device type	01	
Case outlines	C, D	2
Terminal number	Terminal symbol	
1	1A	NC
2	1B	1A
3	NC	1B
4	1C	NC
5	1D	NC
6	1Y	1C
7	GND	NC
8	2Y	1D
9	2A	1Y
10	2B	GND
11	NC	NC
12	2C	2Y
13	2D	2A
14	V <sub>cc</sub>	2B
15	---	NC
16	---	NC
17	---	NC
18	---	2C
19	---	2D
20	---	V <sub>cc</sub>

FIGURE 1. Terminal connections.

<b>STANDARD MICROCIRCUIT DRAWING</b>  <b>DEFENSE SUPPLY CENTER COLUMBUS COLUMBUS, OHIO 43216-5000</b>	<b>SIZE A</b>		<b>5962-97584</b>
		REVISION LEVEL A	SHEET 8

DSCC FORM 2234  
APR 97

■ 9004708 0029828 96T ■



INPUTS				OUTPUT
A	B	C	D	Y
H	H	H	H	L
L	X	X	X	H
X	L	X	X	H
X	X	L	X	H
X	X	X	L	H

FIGURE 2. Truth table.

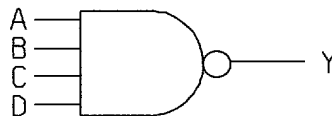
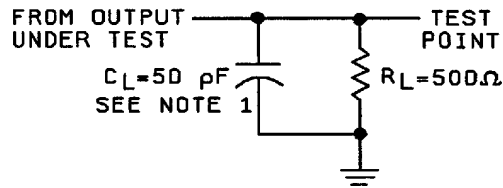
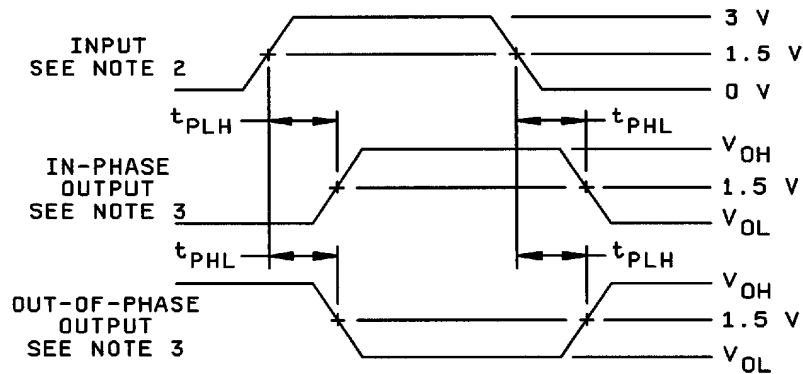

FIGURE 3. Logic diagram.

<b>STANDARD MICROCIRCUIT DRAWING</b>  <b>DEFENSE SUPPLY CENTER COLUMBUS COLUMBUS, OHIO 43216-5000</b>	SIZE <b>A</b>		<b>5962-97584</b>
		REVISION LEVEL A	SHEET 9



LOAD CIRCUIT FOR TOTEM-POLE OUTPUTS



VOLTAGE WAVEFORMS PROPAGATION DELAY TIMES

NOTES:

1.  $C_L$  includes probe and jig capacitance.
2. All input pulses are supplied by generators having the following characteristics:  $PRR \leq 1 \text{ MHz}$ ,  $t_r = t_f \leq 2.5 \text{ ns}$ , duty cycle = 50 %.
3. The outputs are measured one at a time with one transition per measurement.

FIGURE 4. Test circuit and switching waveforms.

<b>STANDARD MICROCIRCUIT DRAWING</b>  <b>DEFENSE SUPPLY CENTER COLUMBUS COLUMBUS, OHIO 43216-5000</b>	<b>SIZE A</b>		<b>5962-97584</b>
		REVISION LEVEL A	SHEET 10

DSCC FORM 2234  
APR 97

9004708 0029830 518

4.4.1 Group A inspection.

- a. Tests shall be as specified in table II herein.
- b. For device class M, subgroups 7 and 8 tests shall be sufficient to verify the truth table. For device classes Q and V, subgroups 7 and 8 shall include verifying the functionality of the device; these tests shall have been fault graded in accordance with MIL-STD-883, test method 5012 (see 1.5 herein).
- c. Subgroups 4, 5, and 6 in table I, method 5005 of MIL-STD-883 shall be omitted.

4.4.2 Group C inspection. The group C inspection end-point electrical parameters shall be as specified in table II herein.

4.4.2.1 Additional criteria for device class M. Steady-state life test conditions, method 1005 of MIL-STD-883:

- a. Test condition A, B, C or D. The test circuit shall be maintained by the manufacturer under document revision level control and shall be made available to the preparing or acquiring activity upon request. The test circuit shall specify the inputs, outputs, biases, and power dissipation, as applicable, in accordance with the intent specified in test method 1005 of MIL-STD-883.
- b.  $T_A = +125$  °C, minimum.
- c. Test duration: 1,000 hours, except as permitted by method 1005 of MIL-STD-883.

TABLE II. Electrical test requirements.

Test requirements	Subgroups (in accordance with MIL-STD-883, method 5005, table I)	Subgroups (in accordance with MIL-PRF-38535, table III)	
	Device class M	Device class Q	Device class V
Interim electrical parameters (see 4.2)			
Final electrical parameters (see 4.2)	<u>1/</u> 1, 2, 3, 7, 8, 9, 10, 11	<u>1/</u> 1, 2, 3, 7, 8, 9, 10, 11	<u>2/</u> 1, 2, 3, 7, 8, 9, 10, 11
Group A test requirements (see 4.4)	1, 2, 3, 7, 8, 9, 10, 11	1, 2, 3, 7, 8, 9, 10, 11	1, 2, 3, 7, 8, 9, 10, 11
Group C end-point electrical parameters (see 4.4)	1, 2, 3	1, 2, 3	1, 2, 3, 7, 8, 9
Group D end-point electrical parameters (see 4.4)	1, 2, 3	1, 2, 3	1, 2, 3
Group E end-point electrical parameters (see 4.4)	1, 7, 9	1, 7, 9	1, 7, 9

1/ PDA applies to subgroup 1.  
2/ PDA applies to subgroups 1 and 7.

<b>STANDARD MICROCIRCUIT DRAWING</b>	<b>SIZE A</b>		<b>5962-97584</b>
		REVISION LEVEL A	SHEET 11
<b>DEFENSE SUPPLY CENTER COLUMBUS COLUMBUS, OHIO 43216-5000</b>			

4.4.2.2 Additional criteria for device classes Q and V. The steady-state life test duration, test condition and test temperature, or approved alternatives shall be as specified in the device manufacturer's QM plan in accordance with MIL-PRF-38535. The test circuit shall be maintained under document revision level control by the device manufacturer's TRB in accordance with MIL-PRF-38535 and shall be made available to the acquiring or preparing activity upon request. The test circuit shall specify the inputs, outputs, biases, and power dissipation, as applicable, in accordance with the intent specified in test method 1005 of MIL-STD-883.

4.4.3 Group D inspection. The group D inspection end-point electrical parameters shall be as specified in table II herein.

4.4.4 Group E inspection. Group E inspection is required only for parts intended to be marked as radiation hardness assured (see 3.5 herein).

- a. End-point electrical parameters shall be as specified in table II herein.
- b. For device classes Q and V, the devices or test vehicle shall be subjected to radiation hardness assured tests as specified in MIL-PRF-38535 for the RHA level being tested. For device class M, the devices shall be subjected to radiation hardness assured tests as specified in MIL-PRF-38535, appendix A for the RHA level being tested. All device classes must meet the postirradiation end-point electrical parameter limits as defined in table I at  $T_A = +25^{\circ}\text{C} \pm 5^{\circ}\text{C}$ , after exposure, to the subgroups specified in table II herein.
- c. When specified in the purchase order or contract, a copy of the RHA delta limits shall be supplied.

5. PACKAGING

5.1 Packaging requirements. The requirements for packaging shall be in accordance with MIL-PRF-38535 for device classes Q and V or MIL-PRF-38535, appendix A for device class M.

6. NOTES

6.1 Intended use. Microcircuits conforming to this drawing are intended for use for Government microcircuit applications (original equipment), design applications, and logistics purposes.

6.1.1 Replaceability. Microcircuits covered by this drawing will replace the same generic device covered by a contractor-prepared specification or drawing.

6.1.2 Substitutability. Device class Q devices will replace device class M devices.

6.2 Configuration control of SMD's. All proposed changes to existing SMD's will be coordinated with the users of record for the individual documents. This coordination will be accomplished in accordance with MIL-STD-973 using DD Form 1692, Engineering Change Proposal.

6.3 Record of users. Military and industrial users should inform Defense Supply Center Columbus when a system application requires configuration control and which SMD's are applicable to that system. DSCC will maintain a record of users and this list will be used for coordination and distribution of changes to the drawings. Users of drawings covering microelectronic devices (FSC 5962) should contact DSCC-VA, telephone (614) 692-0525.

6.4 Comments. Comments on this drawing should be directed to DSCC-VA, Columbus, Ohio 43216-5000, or telephone (614) 692-0674.

6.5 Abbreviations, symbols, and definitions. The abbreviations, symbols, and definitions used herein are defined in MIL-PRF-38535 and MIL-HDBK-1331.

<b>STANDARD MICROCIRCUIT DRAWING</b>  <b>DEFENSE SUPPLY CENTER COLUMBUS COLUMBUS, OHIO 43216-5000</b>	<b>SIZE A</b>		<b>5962-97584</b>
		<b>REVISION LEVEL A</b>	<b>SHEET 12</b>

6.6 Sources of supply.

6.6.1 Sources of supply for device classes Q and V. Sources of supply for device classes Q and V are listed in QML-38535. The vendors listed in QML-38535 have submitted a certificate of compliance (see 3.6 herein) to DSCC-VA and have agreed to this drawing.

6.6.2 Approved sources of supply for device class M. Approved sources of supply for class M are listed in MIL-HDBK-103. The vendors listed in MIL-HDBK-103 have agreed to this drawing and a certificate of compliance (see 3.6 herein) has been submitted to and accepted by DSCC-VA.

<b>STANDARD MICROCIRCUIT DRAWING</b>	<b>SIZE A</b>		<b>5962-97584</b>
	<b>DEFENSE SUPPLY CENTER COLUMBUS COLUMBUS, OHIO 43216-5000</b>	<b>REVISION LEVEL A</b>	<b>SHEET 13</b>

DSCC FORM 2234  
APR 97

■ 9004708 0029833 227 ■

DATE: 97-07-18

Approved sources of supply for SMD 5962-97584 are listed below for immediate acquisition information only and shall be added to MIL-HDBK-103 and QML-38535 during the next revision. MIL-HDBK-103 and QML-38535 will be revised to include the addition or deletion of sources. The vendors listed below have agreed to this drawing and a certificate of compliance has been submitted to and accepted by DSCC-VA. This bulletin is superseded by the next dated revision of MIL-HDBK-103 and QML-38535.

Standard microcircuit drawing PIN <u>1/</u>	Vendor CAGE number	Vendor similar PIN <u>2/</u>
5962-9758401QCA	01295 27014	SNJ54F20J 54F20DMQB
5962-9758401QDA	01295 27014	SNJ54F20W 54F20FMQB
5962-9758401Q2A	01295 27014	SNJ54F20FK 54F20LMQB

1/ The lead finish shown for each PIN representing a hermetic package is the most readily available from the manufacturer listed for that part. If the desired lead finish is not listed, contact the vendor to determine its availability.

2/ **Caution.** Do not use this number for item acquisition. Items acquired to this number may not satisfy the performance requirements of this drawing.

Vendor CAGE  
number

Vendor name  
and address

01295

Texas Instruments Incorporated  
13500 N. Central Expressway  
P.O. Box 655303  
Dallas, TX 75265  
Point of contact: I-20 at FM 1788  
Midland, TX 79711-0448

27014

National Semiconductor  
2900 Semiconductor Drive  
P. O. Box 58090  
Santa Clara, CA 95052-8090  
Point of contact: 333 Western Avenue  
South Portland, ME 04106

The information contained herein is disseminated for convenience only and the Government assumes no liability whatsoever for any inaccuracies in the information bulletin.

■ 9004708 0029834 163 ■