



## DESCRIPTION

The AD2C541 is a bi-directional, single-pole, single-throw, normally open high power solid-state relay. The relay consists of IR LED optically coupled to an IC that drives two rugged source-to-source low on-resistance enhancement type DMOS transistors. With high load current rating (500mA), high isolation (5kV) and compact package size, the AD2C541 is ideally suited to high power applications where board space is at a premium.

## FEATURES

- Low On-Resistance (1 ohm MAX)
- High Load Current (500mA)
- Small package outline (4DIP) - reduces board space
- High input-to-output Isolation (5kV)
- Low input control power consumption (2.5mA TYP)
- Long life / Solid State reliability

## OPTIONS/SUFFIXES\*

- -S Surface Mount leadform option (65 pcs / tube)
- -TR Tape & Reel option (2,000 pcs / reel)
- -V VDE0884 compliant lead spacing (0.4" / 10.16mm)

NOTE: Suffixes listed above are not included in marking on device for part number identification.

## SCHEMATIC DIAGRAM

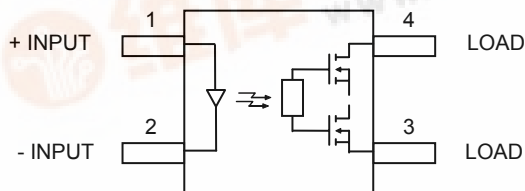

## APPLICATIONS

- Reed relay replacement
- Meter reading systems
- Medical equipment
- Battery monitoring
- Multiplexers

## ABSOLUTE MAXIMUM RATINGS\*

PARAMETER	UNIT	MIN	TYP	MAX
Storage Temperature	°C	-40		150
Operating Temperature	°C	-40		85
Continuous Input Current	mA			50
Transient Input Current (1us)	mA			400
Reverse Input Control Voltage	V			5
Output Power Dissipation	mW			500

\*The values indicated are absolute stress ratings. Functional operation of the device is not implied at these or any conditions in excess of those defined in electrical characteristics section of this document. Exposure to Absolute Ratings may cause permanent damage to the device and may adversely affect reliability.

## APPROVALS

- UL/C-UL Approved: File E201932

**ELECTRICAL CHARACTERISTICS - 25°C**

PARAMETER	UNIT	MIN	TYP	MAX	TEST CONDITIONS
<b>INPUT SPECIFICATIONS</b>					
LED Forward Voltage	V		1.2	1.5	If = 10mA
LED Reverse Voltage	V	6	12		Ir = 10uA
Turn-On Current	m A		2.5	5	Io = 500mA
Turn-Off Current	m A		0.5		
<b>OUTPUT SPECIFICATIONS</b>					
Blocking Voltage	V	60			Io = 1uA
Continuous Load Current	m A			500	If = 5mA
On-Resistance	Ω		0.7	1	Io = 500mA
Leakage Current	μ A		0.07	1	Vo = 60V
Output Capacitance	p F		125	200	Vo = 25V, f = 1.0MHz
Offset Voltage	m V			0.2	If = 5mA
<b>COUPLED SPECIFICATIONS</b>					
Isolation Voltage	V	5000			T = 1 minute
Turn-On Time	m s		1	5	If = 5mA, Io = 500mA
Turn-Off Time	m s		0.075	2	If = 0mA, Io = 500mA
Isolation Resistance	G Ω	100			
Coupled Capacitance	p F		2		
Contact Transient Ratio	V / μ s	2000	7000		dV = 50V

**PERFORMANCE DATA**

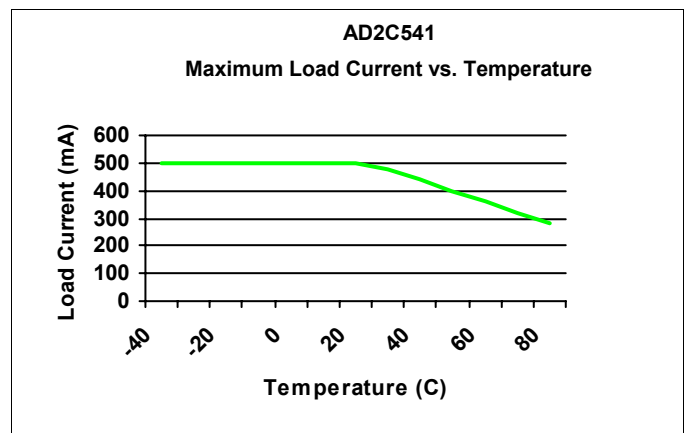
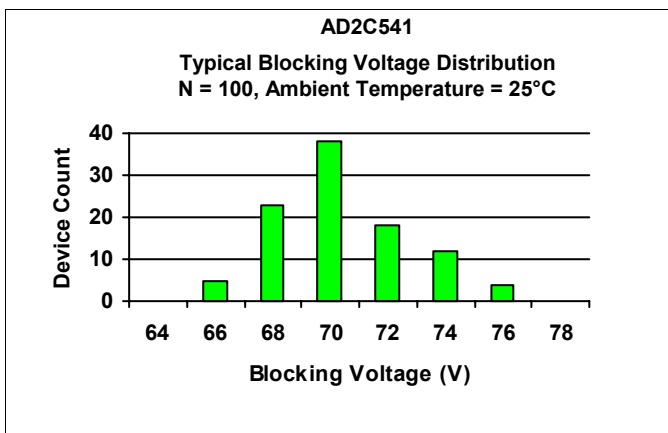
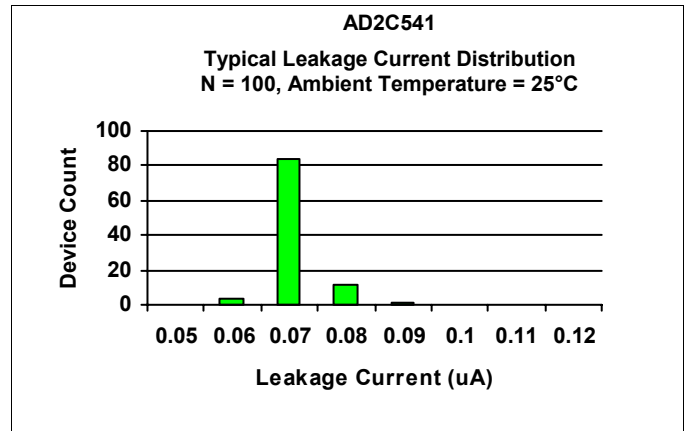
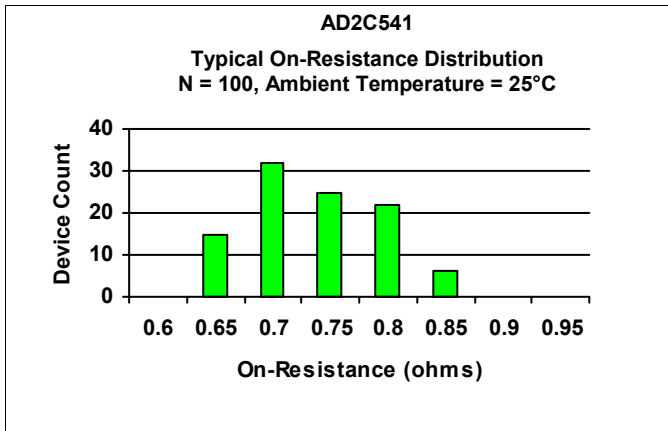
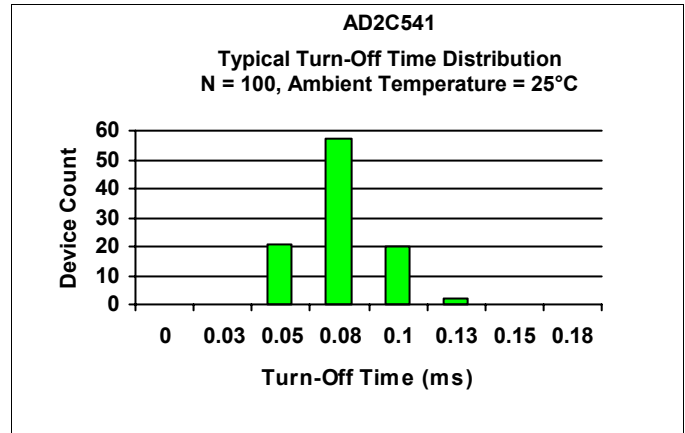
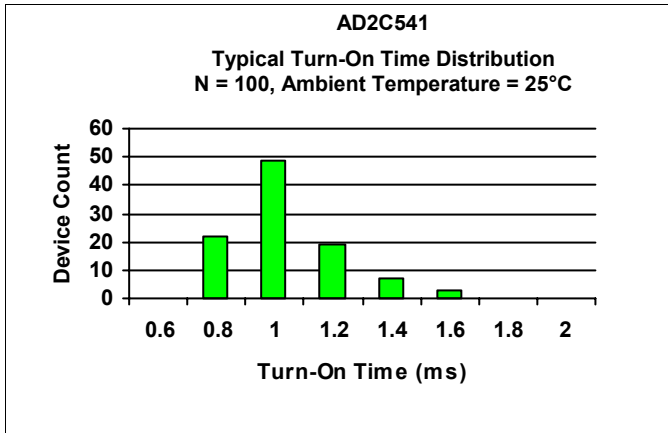

**MECHANICAL DIMENSIONS**

**4 PIN DUAL IN-LINE PACKAGE**

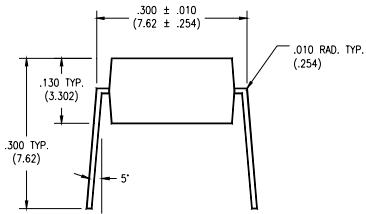

END VIEW

**4 PIN SURFACE MOUNT DEVICE**

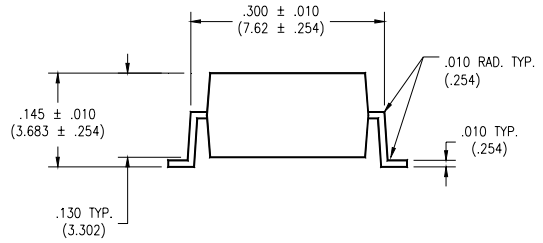

END VIEW

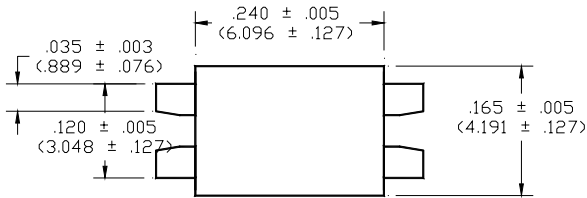

TOP VIEW

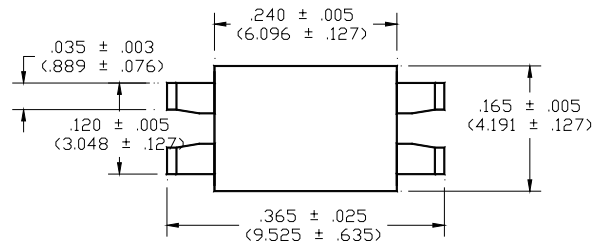

TOP VIEW

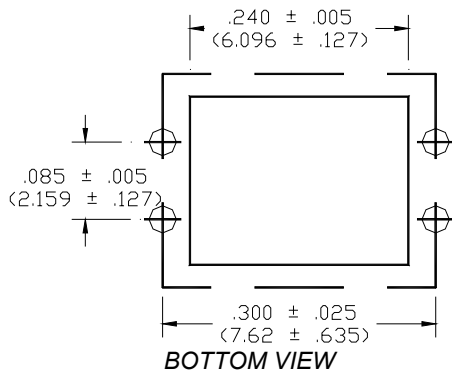

BOTTOM VIEW

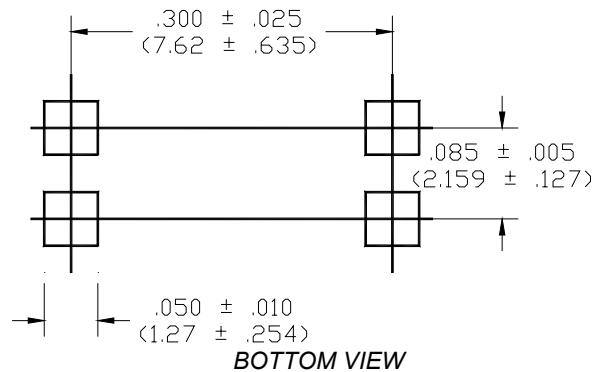

BOTTOM VIEW

## DISCLAIMER

---

*Solid State Optronics (SSO) makes no warranties or representations with regards to the completeness and accuracy of this document. SSO reserves the right to make changes to product description, specifications at any time without further notice. SSO shall not assume any liability arising out of the application or use of any product or circuit described herein. Neither circuit patent licenses nor indemnity are expressed or implied. Except as specified in SSO's Standard Terms & Conditions, SSO disclaims liability for consequential or other damage, and we make no other warranty, expressed or implied, including merchantability and fitness for particular use.*

## LIFE SUPPORT POLICY

---

*SSO does not authorize use of its devices in life support applications wherein failure or malfunction of a device may lead to personal injury or death. Users of SSO devices in life support applications assume all risks of such use and agree to indemnify SSO against any and all damages resulting from such use. Life support devices are defined as devices or systems which, (a) are intended for surgical implant into the body, or (b) support or sustain life, and (c) whose failure to perform when used properly in accordance with instructions for use can be reasonably expected to result in significant injury to the user, or (d) a critical component in any component of a life support device or system whose failure can be reasonably expected to cause failure of the life support device or system, or to affect its safety or effectiveness.*