



# MBRS1090 THRU MBRS10100

## 10.0 AMPS. Schottky Barrier Rectifiers



Voltage Range  
90 to 100 Volts  
Current  
10.0 Amperes

### Features

- ✦ Plastic material used carries Underwriters Laboratory Classifications 94V-0
- ✦ Metal silicon junction, majority carrier conduction
- ✦ Low power loss, high efficiency
- ✦ High current capability, low forward voltage drop
- ✦ High surge capability
- ✦ For use in low voltage, high frequency inverters, free wheeling, and polarity protection applications
- ✦ Guardring for overvoltage protection
- ✦ High temperature soldering guaranteed:  
260°C/10 seconds, 0.25"(6.35mm) from case

### Mechanical Data

- ✦ Cases: JEDEC D2PAK molded plastic body
- ✦ Terminals: Lead solderable per MIL-STD-750, Method 2026
- ✦ Polarity: As marked
- ✦ Mounting position: Any
- ✦ Mounting torque: 5 in. - lbs. max
- ✦ Weight: 0.08 ounce, 2.24 grams

### D<sup>2</sup>PAK

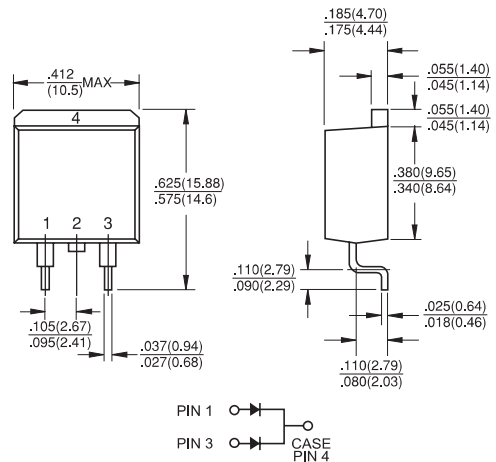

Dimensions in inches and (millimeters)

### Maximum Ratings and Electrical Characteristics

Rating at 25°C ambient temperature unless otherwise specified.

Single phase, half wave, 60 Hz, resistive or inductive load.

For capacitive load, derate current by 20%

Type Number	Symbol	MBRS1090	MBRS10100	Units
Maximum Recurrent Peak Reverse Voltage	$V_{RRM}$	90	100	V
Maximum RMS Voltage	$V_{RMS}$	63	70	V
Maximum DC Blocking Voltage	$V_{DC}$	90	100	V
Maximum Average Forward Rectified Current See Fig. 1	$I_{(AV)}$	10		A
Peak Forward Surge Current, 8.3 ms Single Half Sine-wave Superimposed on Rated Load (JEDEC method)	$I_{FSM}$	150		A
Peak Repetitive Reverse Surge Current (Note 1)	$I_{RRM}$	0.5		A
Maximum Instantaneous Forward Voltage at (Note 2) $I_F=5.0A, T_C=25^\circ C$ $I_F=5.0A, T_C=125^\circ C$ $I_F=10A, T_C=25^\circ C$ $I_F=10A, T_C=125^\circ C$	$V_F$	0.80 0.65 0.95 0.75		V
Maximum Instantaneous Reverse Current @ $T_J=25^\circ C$ at Rated DC Blocking Voltage (Note 2) @ $T_J=100^\circ C$	$I_R$	100 6.0		$\mu A$ mA
Maximum Thermal Resistance, Junction to Case	$R_{\theta JA}$ $R_{\theta JC}$	60 2.0		$^\circ C/W$
Operating Junction Temperature Range	$T_J$	-65 to +175		$^\circ C$
Storage Temperature Range	TSTG	-65 to +175		$^\circ C$

Notes: 1. 2.0us Pulse Width, f=1.0 KHz

2. Pulse Test: 300us Pulse Width, 1% Duty Cycle

RATINGS AND CHARACTERISTIC CURVES (MBRS1090 THRU MBRS10100)

FIG.1- FORWARD CURRENT DERATING CURVE

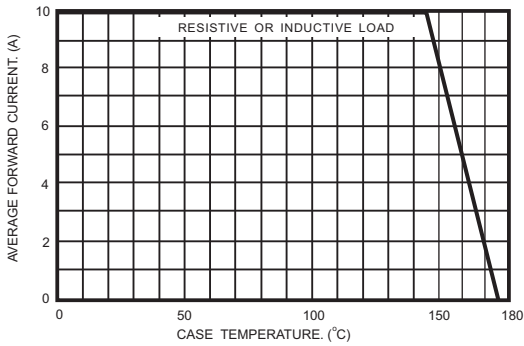

FIG.2- MAXIMUM NON-REPETITIVE PEAK FORWARD SURGE CURRENT PER LEG

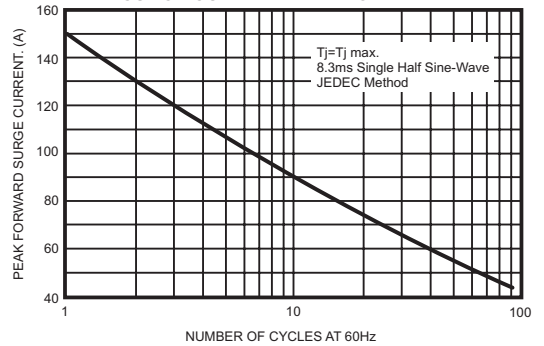

FIG.3- TYPICAL INSTANTANEOUS FORWARD CHARACTERISTICS PER LEG

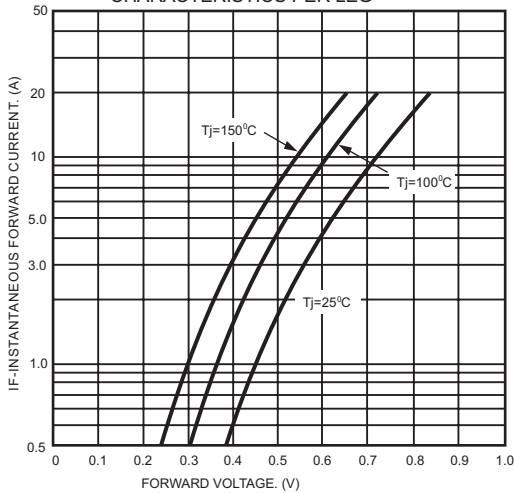

FIG.4- TYPICAL REVERSE CHARACTERISTICS PER LEG

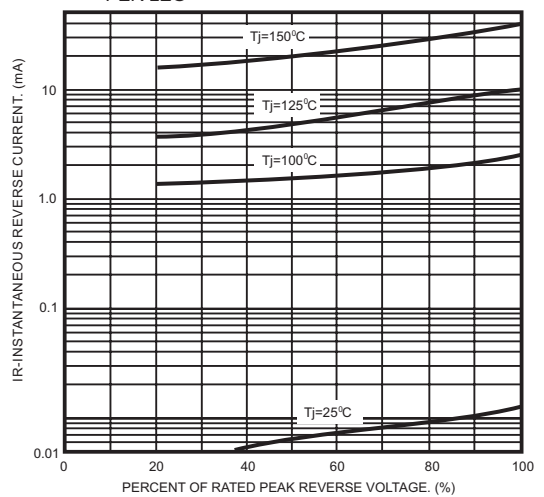

FIG.5- TYPICAL TRANSIENT THERMAL IMPEDANCE PER LEG

