

THIS DRAWING IS UNPUBLISHED. RELEASED FOR PUBLICATION, 19

© COPYRIGHT 19

BY AMP INCORPORATED. ALL INTERNATIONAL RIGHTS RESERVED.

[查询"206138-1"供应商](#)

MOD	LOC	DIST	P	F	ZONE	LTR	DESCRIPTION	DATE	APPD
4	BD	35				L	REDRAWN	4/23/91	-
						M	REV PER ECN BD6815	10/16/92	KB
						M1	ADDED -6 NPR 4832	07/06/93	AF
						N	OBSOLETE -3 PER EC0020-857-93	12/17/93	AF

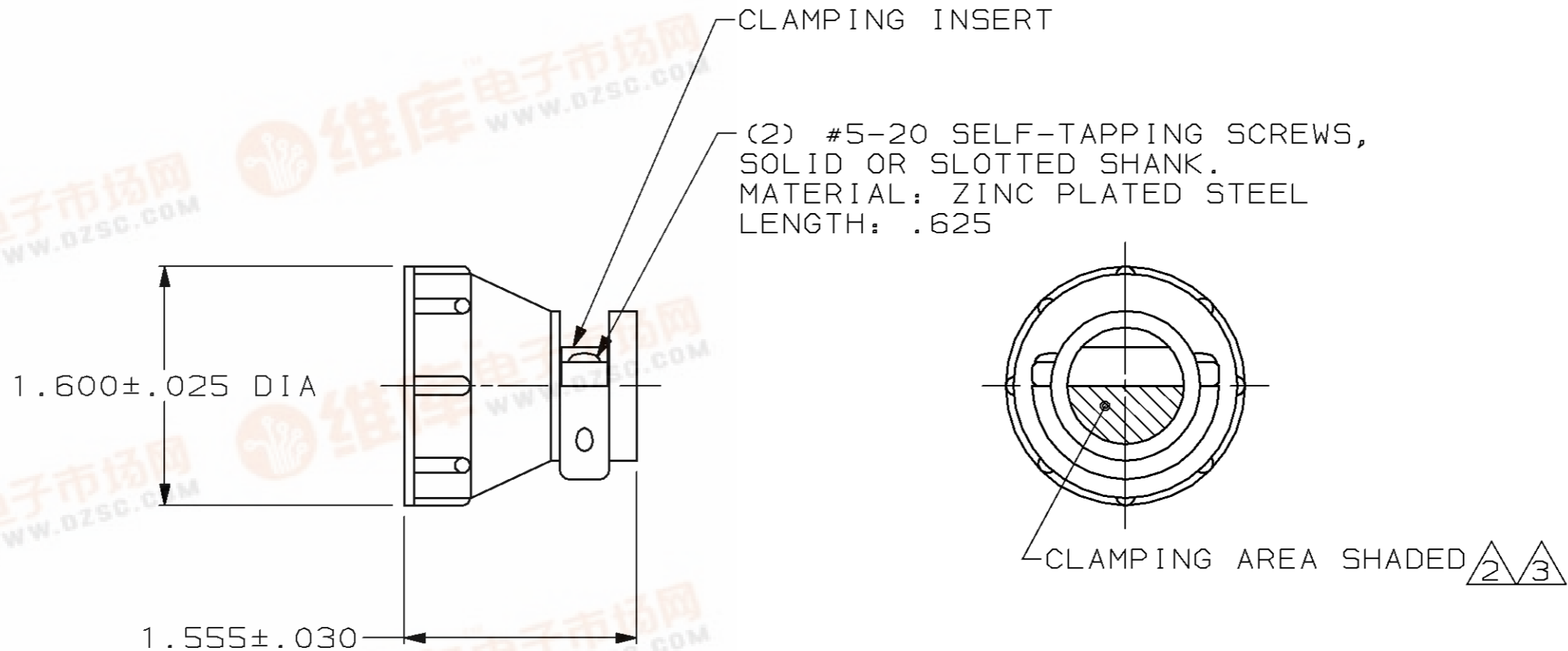

1. PARTS PACKAGED UNASSEMBLED.
2. CABLE CLAMPING AREA ADJUSTABLE FROM .100 TO .410 SQ IN BY REVERSING CLAMPING INSERTS. (2 INSERTS SUPPLIED, -1 AND -2 ONLY)
3. CABLE CLAMPING AREA ADJUSTABLE FROM .100 TO .410 SQ IN BY CHANGING CLAMPING INSERTS. (4 INSERTS SUPPLIED, -3 ONLY)
4. .703 MAXIMUM CABLE OUTSIDE DIAMETER.
5. BULK PACKAGED KITS TO BE ORDERED IN MULTIPLES OF 100 ONLY.

	SMALL PACK	206138-6
OBSOLETE	5 BULK	206138-3
	5 BULK	206138-2
	INDIVIDUAL	206138-1
	PACKAGING	PART NUMBER

DO NOT SCALE PRINT. UNLESS SPECIFIED DIMENSIONS IN INCHES TOLERANCES ON: 2 PLC DEC ± - 3 PLC DEC ± - ANGLES ± -	DR 4/23/91 A GRAFF	AMP Incorporated Harrisburg, PA 17105-3608
	CHK 7-22-92 W.G. LENKER	
	APPD 7-22-92 K. BEAVER	
	APPD 7-22-92 C. ROHDE	
MATERIAL THERMOPLASTIC, BLACK	PRODUCT SPEC 108-10024	NAME CABLE CLAMP KIT, STANDARD, SHELL SIZE 23, CPC
FINISH -	APPLICATION SPEC -	
	WEIGHT -	SIZE B CAGE CODE 00779 DRAWING NO 206138 SCALE 1:1 SHEET 1 OF 1

CUSTOMER DRAWING

