

# **SPECIFICATIONS**

|                 |                          |
|-----------------|--------------------------|
| <b>MODEL</b>    | <b>INFRARED LAMP LED</b> |
| <b>PART NO.</b> | <b>LI521</b>             |

[Contents]

|     |                                       |    |
|-----|---------------------------------------|----|
| 1.  | Devices -----                         | 2  |
| 2.  | Outline Dimensions -----              | 2  |
| 3.  | Absolute Maximum Ratings -----        | 3  |
| 4.  | Electro-Optical Characteristics ----- | 4  |
| 5.  | Reliability Tests -----               | 5  |
| 6.  | Characteristic Diagrams -----         | 6  |
| 7.  | Bin Code Description -----            | 8  |
| 8.  | Packing -----                         | 9  |
| 9.  | Soldering Profile -----               | 12 |
| 10. | Reference -----                       | 13 |
| 11. | Precaution For Use -----              | 14 |

---

<050201> Rev. 0.0

LI521



**SEOUL SEMICONDUCTOR CO., LTD.**

148-29, Kasan-Dong, Keumchun-Gu, Seoul, Korea

TEL : 82-2-3281-6269 FAX : 82-2-857-5430

## 1. DEVICES

| Part Number | Lens        |              | Source      |          |
|-------------|-------------|--------------|-------------|----------|
|             | Color       | Diffusion    | Dice Source | Color    |
| LI521       | Water Clear | Non-Diffused | GaAlAs/GaAs | Infrared |

## 2. OUTLINE DEMENSIONS

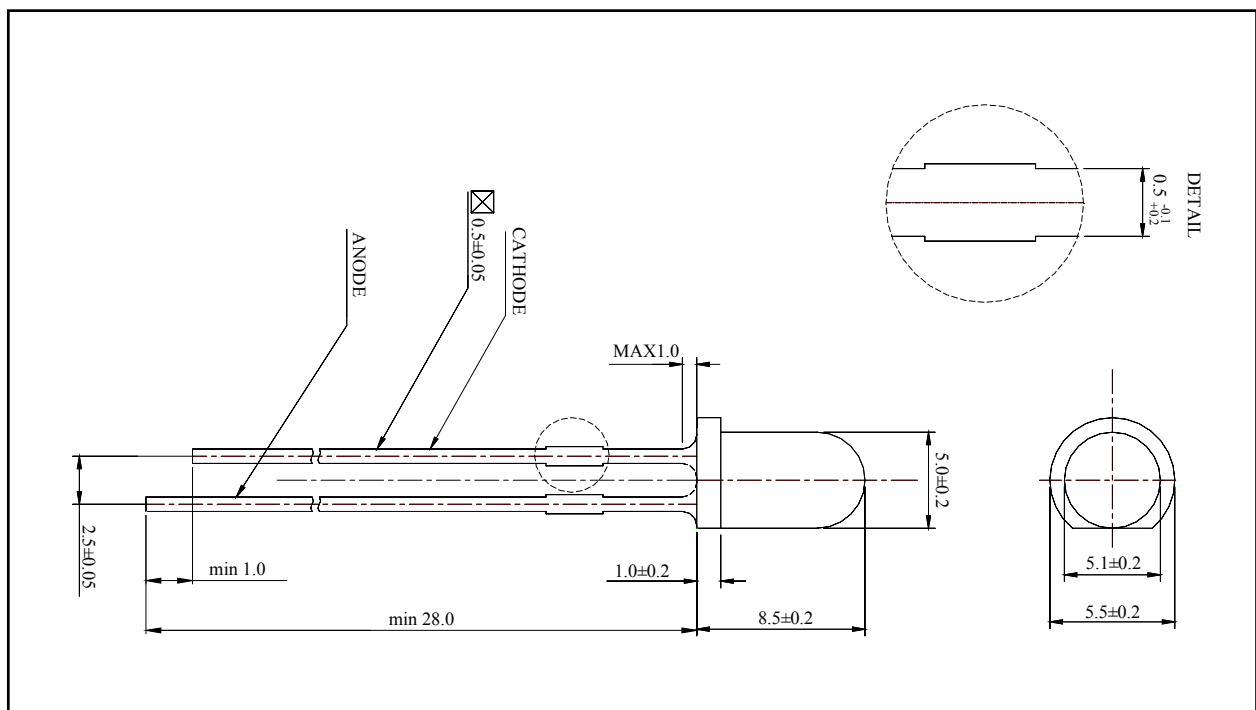

- Notes : 1. All dimensions are in millimeters.  
 2. Protruded epoxy is 1.0mm maximum.

<050201> Rev. 0.0

LI521



**SEOUL SEMICONDUCTOR CO., LTD.**  
 148-29, Kasan-Dong, Keumchun-Gu, Seoul, Korea  
 TEL : 82-2-3281-6269 FAX : 82-2-857-5430

### 3. ABSOLUTE MAXIMUM RATINGS (at $T_a = 25^\circ\text{C}$ )

| Item                       | Symbol     | Value                             | Unit |
|----------------------------|------------|-----------------------------------|------|
| DC Forward Current         | $I_F$      | 100                               | mA   |
| Forward Peak Pulse Current | $I_{FP}^1$ | 1000                              | mA   |
| Reverse Voltage            | $V_R$      | 5                                 | V    |
| Power Dissipation          | $P_D$      | 150                               | mW   |
| Operating Temperature      | $T_{opr}$  | -40 ~ 100                         | °C   |
| Storage Temperature        | $T_{stg}$  | -40 ~ 105                         | °C   |
| Solder Temperature         | $T_S$      | 260 °C for 10 second <sup>2</sup> | °C   |

Notes : 1.  $t \leq 0.1\text{ms}$ ,  $D = 1/10$

2. 3mm bellow seating plane

#### 4. ELECTRO-OPTICAL CHARACTERISTICS (at $I_F = 50\text{mA}$ , $T_a = 25^\circ\text{C}$ )

| Item                                    | Symbol          | Value |      |      | Unit          |
|-----------------------------------------|-----------------|-------|------|------|---------------|
|                                         |                 | Min.  | Typ. | Max. |               |
| Radiant Intensity <sup>1</sup>          | $I_E$           | 80    | 120  | -    | mW/sr         |
| Peak Wavelength                         | $\lambda_P$     | -     | 870  | -    | nm            |
| Forward Voltage                         | $V_F$           | -     | 1.5  | 1.8  | V             |
| View Angle                              | $2\theta_{1/2}$ | 20    |      |      | deg.          |
| Reverse Current (at $V_R = 5\text{V}$ ) | $I_R$           | -     | -    | 10   | $\mu\text{A}$ |

Note : 1. Radiant Intensity Tolerance  $\pm 10\%$

## 5. RELIABILITY TESTS

| Item                           | Condition                                                                                              | Note      | Failures |
|--------------------------------|--------------------------------------------------------------------------------------------------------|-----------|----------|
| Life Test                      | $T_a = RT, I_F = 50mA$                                                                                 | 1000hrs   | 0/22     |
| High Temperature Operating     | $T_a = 100^{\circ}C, I_F = 10mA$                                                                       | 1000hrs   | 0/22     |
| Low Temperature Operating      | $T_a = -40^{\circ}C, I_F = 20mA$                                                                       | 1000hrs   | 0/22     |
| Thermal Shock                  | $T_a = -40^{\circ}C$ (30min) ~ $105^{\circ}$ (30min)<br>(Transfer time : 5sec, 1Cycle = 1hr)           | 100cycles | 0/50     |
| Temperature Cycle              | $T_a = -40^{\circ}C$ (25min) ~ $25^{\circ}C$ (5min) ~<br>$105^{\circ}C$ (25min) ~ $25^{\circ}C$ (5min) | 100cycles | 0/50     |
| Moisture Resistance Cycle      | $T_a = 25^{\circ}C \sim 65^{\circ}C \sim -10^{\circ}C, RH = 90\%$<br>(1Cycle = 24hrs)                  | 10cycles  | 0/50     |
| Resistance to soldering Heat   | $T_s = 260 \pm 5^{\circ}C, t = 10 \pm 1sec$                                                            | 1 time    | 0/50     |
| ESD<br>(Human Body Model)      | 1kV, 1.5k $\Omega$ ; 100pF                                                                             | 1 time    | 0/22     |
| High Temperature Storage       | $T_a = 105^{\circ}C$                                                                                   | 1000hrs   | 0/50     |
| Low Temperature Storage        | $T_a = -40^{\circ}C$                                                                                   | 1000hrs   | 0/50     |
| Temperature Humidity Storage   | $T_a = 85^{\circ}C, RH = 85\%$                                                                         | 1000hrs   | 0/50     |
| Temperature Humidity Operating | $T_a = 85^{\circ}C, RH = 85\%$<br>$I_F = 15mA$                                                         | 100hrs    | 0/22     |

### < Judging Criteria For Reliability Tests >

|       |                        |
|-------|------------------------|
| $V_F$ | USL <sup>1</sup> X 1.2 |
| $I_R$ | USL X 2.0              |
| $I_V$ | LSL <sup>2</sup> X 0.7 |

Notes : 1. USL : Upper Standard Level

2. LSL : Lower Standard Level.

<050201> Rev. 0.0

LI521



**SEOUL SEMICONDUCTOR CO., LTD.**

148-29, Kasan-Dong, Keumchun-Gu, Seoul, Korea

TEL : 82-2-3281-6269 FAX : 82-2-857-5430

## 6. CHARACTERISTIC DIAGRAMS

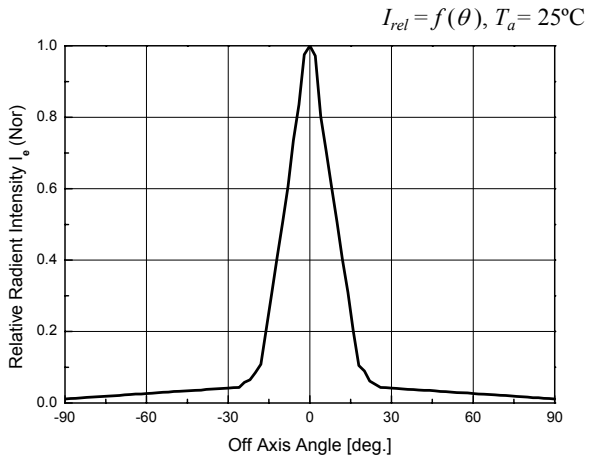

Off Axis Angle vs. Relative Intensity

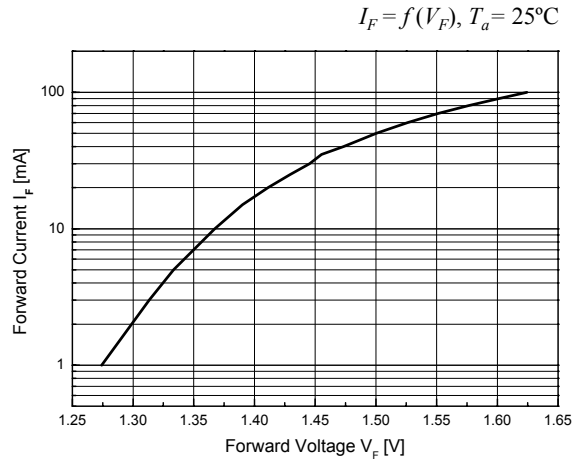

Forward Voltage vs. Forward Current

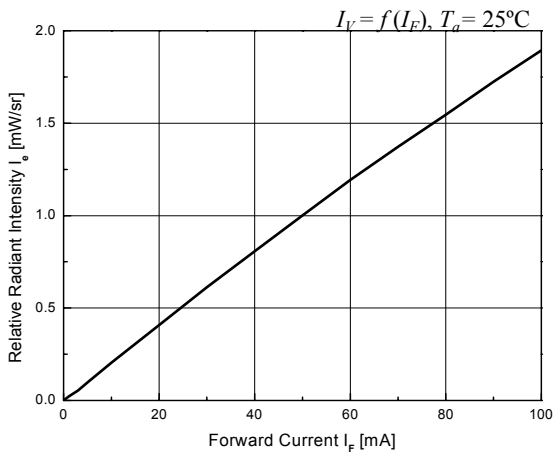

Forward Current vs. Relative Intensity

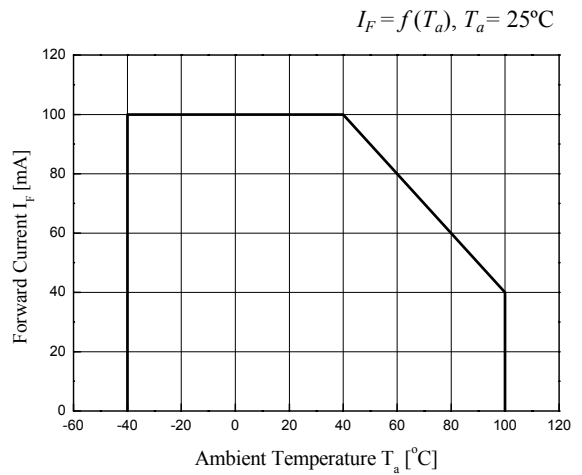

Ambient Temperature vs. Forward Current

<050201> Rev. 0.0

LI521



**SEOUL SEMICONDUCTOR CO., LTD.**

148-29, Kasan-Dong, Keumchun-Gu, Seoul, Korea

TEL : 82-2-3281-6269 FAX : 82-2-857-5430

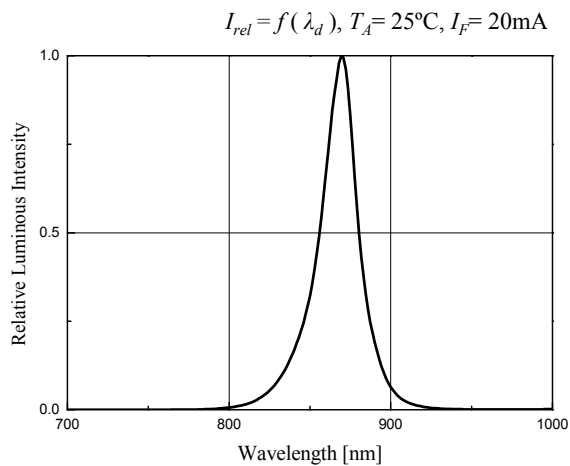

**Wavelength vs. Relative Intensity**

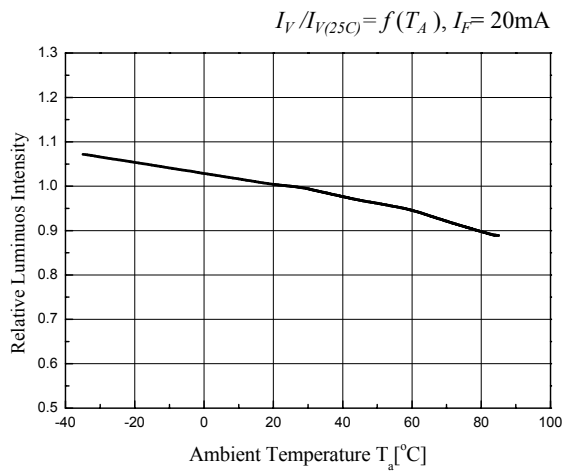

**Ambient Temperature vs. Relative Intensity**

## 7. BIN CODE DESCRIPTION

| BIN CODE          |   |                 |
|-------------------|---|-----------------|
| Radiant Intensity | * | Forward Voltage |
| A                 | * | 1               |



| Radiant Intensity (mW/sr)<br>@ $I_F = 50\text{mA}$ |      |      |
|----------------------------------------------------|------|------|
| BIN CODE                                           | Min. | Max. |
| A                                                  | 80   | -    |

| Forward Voltage (V)<br>@ $I_F = 50\text{mA}$ |      |      |
|----------------------------------------------|------|------|
| BIN CODE                                     | Min. | Max. |
| 1                                            | 1.3  | 1.8  |



## 8. PACKING

### 1) Bulk Packing

#### (1) Antistatic poly vinyl bag apply

Poly bag:

5 $\phi$  Lamp Series : 500pcs

3 $\phi$  Lamp Series : 500pcs

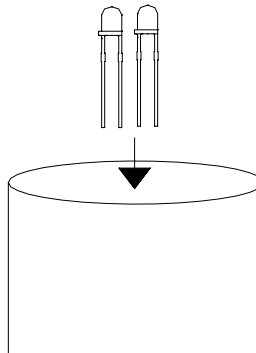

#### (2) Inner box structure

Box : 2 poly bags

|                                                     |  |         |  |
|-----------------------------------------------------|--|---------|--|
|                                                     |  | P/O No. |  |
| Lot No.                                             |  |         |  |
| SEOUL SEMICONDUCTOR CO.,LTD<br>TEL : (02) 3281-6269 |  |         |  |

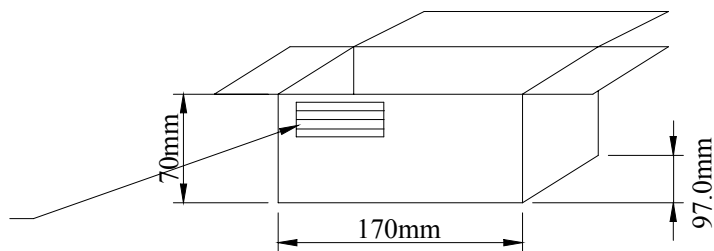

#### (3) Outer box structure

Box : 27 boxes

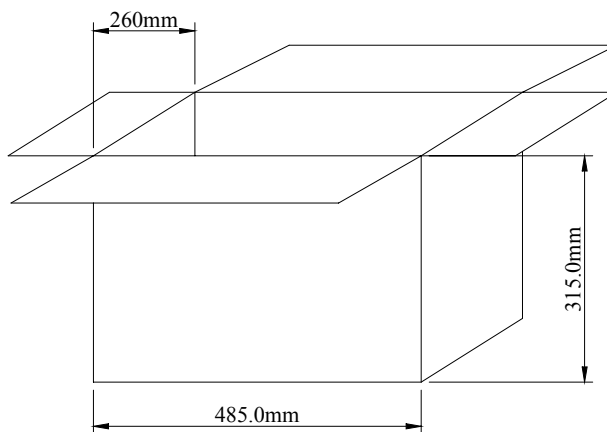

<050201> Rev. 0.0

LI521



**SEOUL SEMICONDUCTOR CO., LTD.**

148-29, Kasan-Dong, Keumchun-Gu, Seoul, Korea

TEL : 82-2-3281-6269 FAX : 82-2-857-5430

## 2) Tapping Outline Dimensions

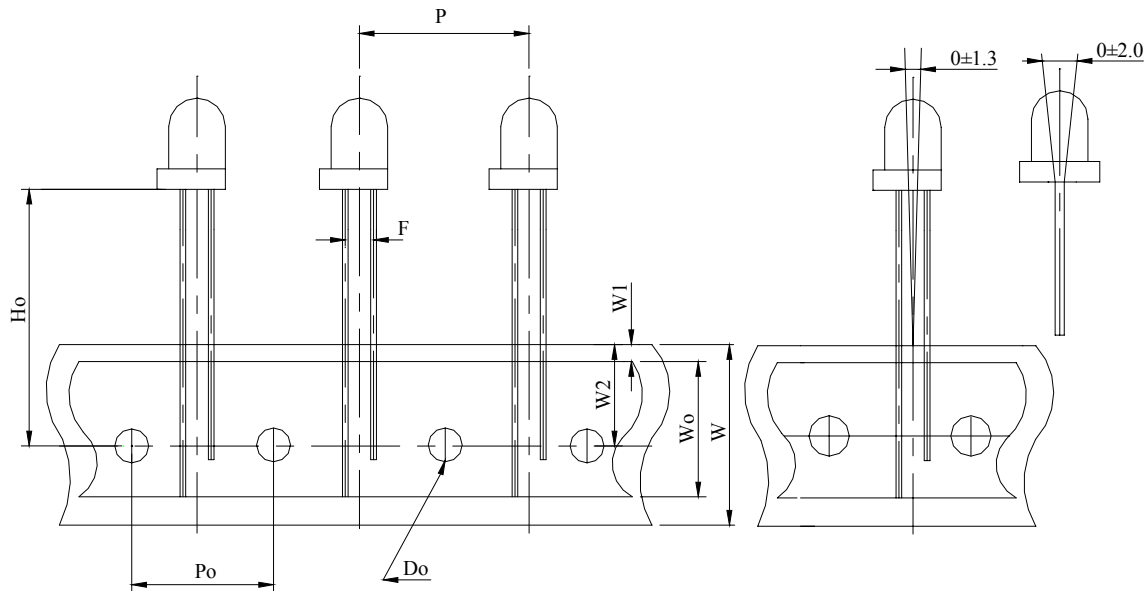

| Package Dimensions (unit : mm) |                                      |    |          |
|--------------------------------|--------------------------------------|----|----------|
| Ho*                            |                                      | P  | 12.7±0.5 |
| W                              | 18.0 <sup>+1.0</sup> <sub>-0.5</sub> | Po | 12.7±0.3 |
| W0                             | 13.0±0.3                             | F  | 2.54±0.5 |
| W1                             | 1.0±0.5                              | Do | φ4.0±0.5 |
| W2                             | 9.0±0.5                              |    |          |

\* Remark : Ho - users define.

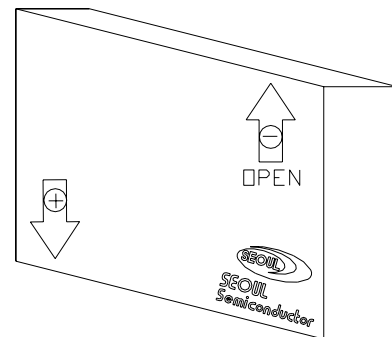

1 Box contain quantity.

\* 3φ Series : 3000pcs

\* 5φ Series : 2000pcs

### 3) Forming Outline Dimensions

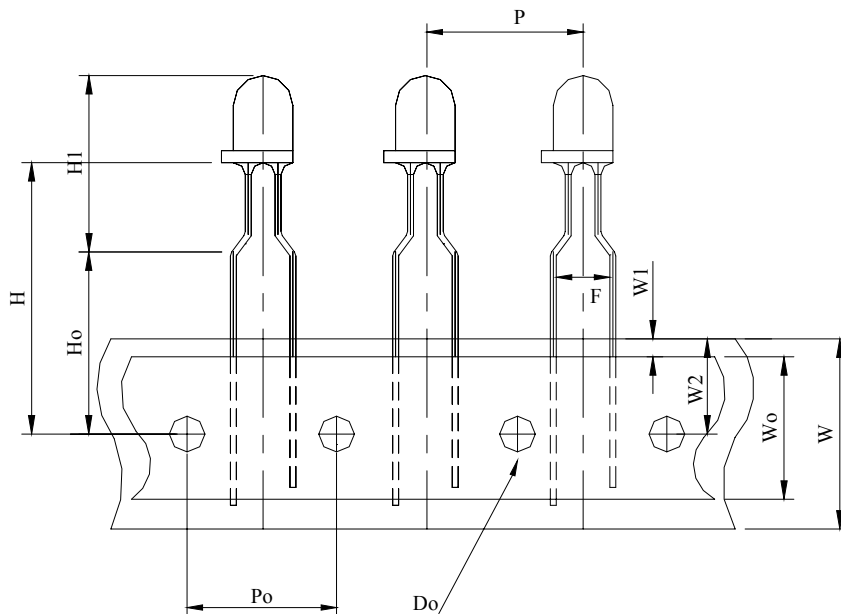

| Package Dimensions (unit : mm) |                                      |    |          |
|--------------------------------|--------------------------------------|----|----------|
| H *                            |                                      | W2 | 9.0±0.5  |
| Ho *                           |                                      | P  | 12.7±0.5 |
| H1 *                           |                                      | Po | 12.7±0.3 |
| W                              | 18.0 <sup>+1.0</sup> <sub>-0.5</sub> | F  | 5.0±0.5  |
| Wo                             | 13.0±0.3                             | Do | φ4.0±0.5 |
| W1                             | 1.0±0.5                              |    |          |

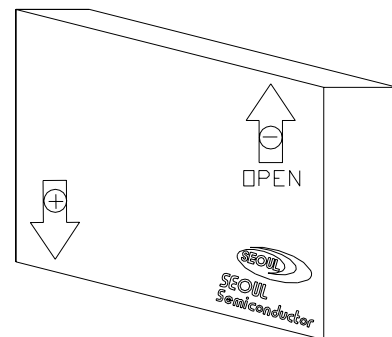

1 Box contain quantity.

\* 3φ Series : 2000pcs

\* 5φ Series : 1500pcs

\* Remark : H / Ho / H1- users define.

## 9. SOLDERING PROFILE

### 1) Wave Soldering Conditions / Profile

- Preliminary heating to be at 85°C(120 °C max) for 20 seconds(60 seconds max).
- Soldering heat to be at 235 °C (260°C max) for 5 seconds (10 seconds max.)
- Soak time above 200 °C is 5 seconds

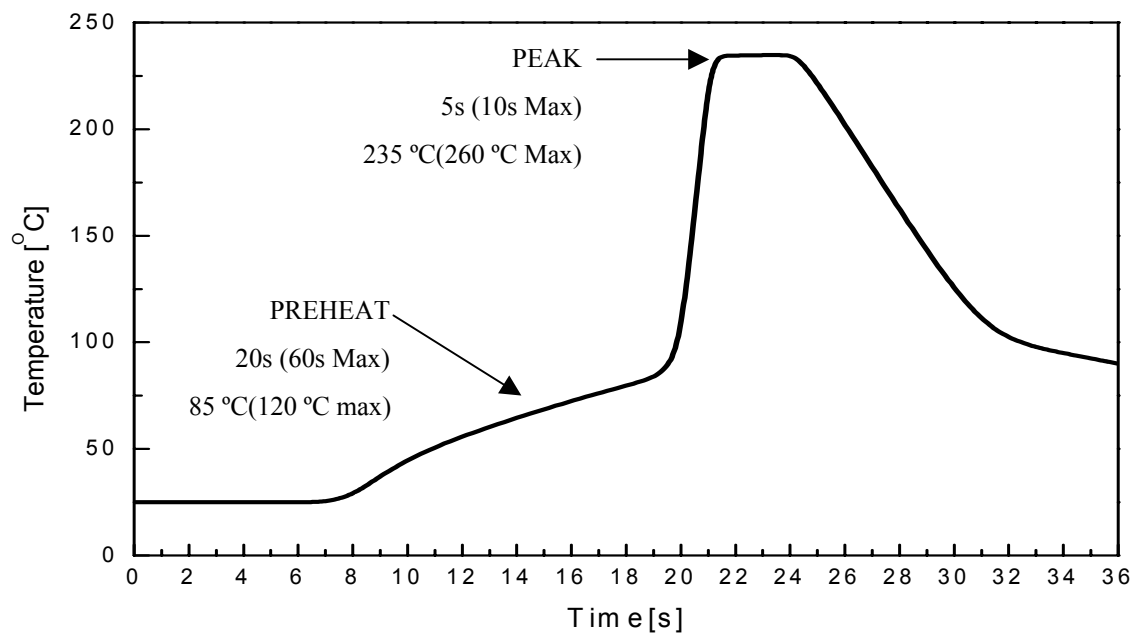

### 2) Hand Soldering conditions

- Not more than 5 seconds at max. 300°C, under Soldering iron.

Note : In case the soldered products are reused in soldering process, we don't guarantee the products.

## 10. PART NUMBERING SYSTEM

|   |   |   |   |   |   |   |   |   |   |   |   |
|---|---|---|---|---|---|---|---|---|---|---|---|
| 1 | 2 | 3 | 4 | 5 | 6 | 7 | 8 |   | A | B | C |
| L | * | * | * | * | * | * | * | - | * | * | * |

1) Lamp LED initial

2) Color

U : Ultra Violet,                      B : Blue (460~490),                      C : Cyan (490~510),  
 T : True Green (510~540), G : Yellow-Green (540~580)  
 Y : Yellow (580~600)                  O : Orange (600~620)                      R : Red (620~700)  
 W : White                                  M : Warm                                      I : Infrared

3) If the products have 2 or 3chips

GR : Green + Red ( according to wavelength), FL : Full color

4) Outline type

1 : 3x2(square),    2 : 5x2(square),    3 : Phi3,    5 : Phi 5 ,  
 6 : 3Phi Oval,    7 : 5Phi Oval

5) Half angle

1: ~14°, 2: 15~24°, 3: 25~34°, 4: 35~44°, 5 : 45~54°... 0 : more than 100°

6) 1<sup>st</sup> Development according to a chip

7) 2<sup>nd</sup> Development (other material)

D : diffused C : colored Z : zener chip attached

8) Stand off type

A, B, C : Bin cord description A: IV, B: WD C: VF



## 11. PRECAUTION FOR USE

- 1) In order to avoid the absorption of moisture, it is recommended to store in the dry box (or desiccators) with a desiccant .
- 2) In case of more than 1 week passed after opening or change color of indicator on desiccant components shall be dried 10-12Hr, at  $60\pm 5^{\circ}\text{C}$ .
- 3) In case of supposed the components is humid, shall be dried dip-solder just before, 12Hr at  $80\pm 5^{\circ}\text{C}$  or 10Hr at  $100\pm 5^{\circ}\text{C}$ .
- 4) Any mechanical force or any excess vibration shall not be accepted to apply during cooling process to normal temp. after soldering.
- 5) Quick cooling shall not be avoid.
- 6) Components shall not be mounted on warped direction of PCB.
- 7) Anti radioactive ray design is not considered for the products listed here in.
- 8) This device should not be used in any type of fluid such as water, oil, organic solvent and etc. When washing is required, IPA should be used.
- 9) When the LEDs are illuminating, operating current should be decided after considering the ambient maximum temperature.
- 10) LEDs must be stored to maintain a clean atmosphere. If the LEDs are stored for 3 months or more after being shipped from SSC, a sealed container with a nitrogen atmosphere should be used for storage.
- 11) The LEDs must be soldered within seven days after opening the moisture-proof packing.
- 12) Repack unused products with anti-moisture packing, fold to close any opening and then store in a dry place.
- 13) The appearance and specifications of the product may be modified for improvement without notice.

