

# HANDWHEELS

[查询"1507/M-M6-35"供应商](#)

TYPE

PATTERN



THREAD OR BORE

LENGTH OF MALE THREAD

## Scallop handwheel - high impact resistant

**RENKOL**

3

Matt finish thermoplastic

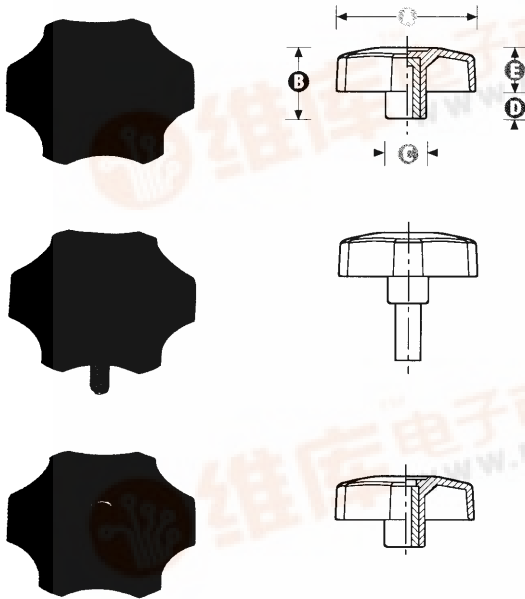

TYPE	PATTERN	28	17	11	6	11	THREAD OR BORE	LENGTH OF MALE THREAD
FEMALE	<b>I525</b>	28	17	11	6	11	M5 M6	
Aluminium insert	<b>I513</b>	40	20	15	8	12	M6 M8	
	<b>I514</b>	50	24	15	9	15	M6 M8	
	<b>I515</b>	60	30	19	12	18	M8 M10	
MALE	<b>I525/M</b>	28	17	11	6	11	M5 M6	10 15 20
Plated steel insert	<b>I513/M</b>	40	20	15	8	12	M6 M8	15 20 25 35
	<b>I514/M</b>	50	24	15	9	15	M6 M8	20 25 35 40
	<b>I515/M</b>	60	30	19	12	18	M8 M10	20 30 40
THREADED RIGHT THROUGH	<b>I525/T</b>	28	17	11	6	11	M5 M6	
Aluminium insert	<b>I513/T</b>	40	20	15	8	12	M6 M8	
	<b>I514/T</b>	50	24	15	9	15	M6 M8	
	<b>I515/T</b>	60	30	19	12	18	M8 M10	

## Star handwheel - high impact resistant

Matt finish thermoplastic

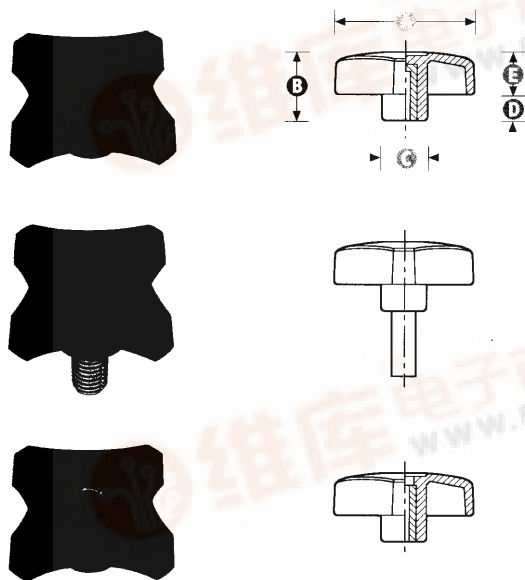

TYPE	PATTERN	28	17	11	6	11	THREAD OR BORE	LENGTH OF MALE THREAD
FEMALE	<b>I526</b>	28	17	11	6	11	M5 M6	
Aluminium insert	<b>I507</b>	40	20	15	8	12	M6 M8	
	<b>I508</b>	50	24	15	9	15	M6 M8	
	<b>I509</b>	60	30	19	12	18	M8 M10	
MALE	<b>I526/M</b>	28	17	11	6	11	M5 M6	10 15 20
Plated steel insert	<b>I507/M</b>	40	20	15	8	12	M6 M8	15 20 25 35
	<b>I508/M</b>	50	24	15	9	15	M6 M8	20 25 35 40
	<b>I509/M</b>	60	30	19	12	18	M8 M10	20 30 40
THREADED RIGHT THROUGH	<b>I526/T</b>	28	17	11	6	11	M5 M6	
Aluminium insert	<b>I507/T</b>	40	20	15	8	12	M6 M8	
	<b>I508/T</b>	50	24	15	9	15	M6 M8	
	<b>I509/T</b>	60	30	19	12	18	M8 M10	

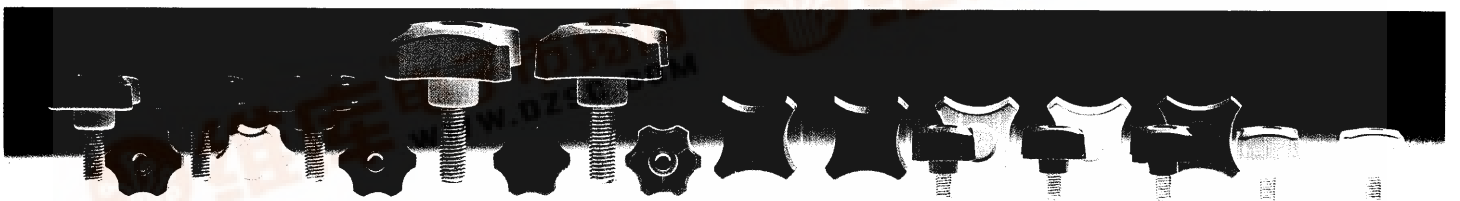

TYPE

PATTERN



THREAD OR BORE

LENGTH OF MALE THREAD

Non standard thread diameters, lengths, insert materials and other modifications are available for minimum quantities. The standard colour is black. These patterns are available in a choice of colours. Contact our sales department for details.

All dimensions in mm and are approximate