

REVISIONS													
LTR	DESCRIPTION	DATE (YR-MO-DA)	APPROVED										

REV													
SHEET													
REV													
SHEET													
REV STATUS OF SHEETS	REV												
	SHEET	1	2	3	4	5	6	7	8				

PMIC N/A	PREPARED BY <i>Christopher A. Ranch</i>	DEFENSE ELECTRONICS SUPPLY CENTER DAYTON, OHIO 45444		
<b>STANDARDIZED MILITARY DRAWING</b>	CHECKED BY <i>Ray Monnin</i>	MICROCIRCUIT, LINEAR, VOLTAGE REFERENCE, MONOLITHIC SILICON		
	APPROVED BY 			
	THIS DRAWING IS AVAILABLE FOR USE BY ALL DEPARTMENTS AND AGENCIES OF THE DEPARTMENT OF DEFENSE  AMSC N/A	DRAWING APPROVAL DATE 11 JULY 1988	SIZE <b>A</b>	CAGE CODE <b>67268</b>
	REVISION LEVEL	SHEET    1    OF    8		

DESC FORM 193  
SEP 87

\* U.S. GOVERNMENT PRINTING OFFICE: 1987 - 748-129/60911  
5962-E828

**DISTRIBUTION STATEMENT A.** Approved for public release; distribution is unlimited.

1. SCOPE

1.1 Scope. This drawing describes device requirements for class B microcircuits in accordance with 1.2.1 of MIL-STD-883, "Provisions for the use of MIL-STD-883 in conjunction with compliant non-JAN devices".

1.2 Part number. The complete part number shall be as shown in the following example:

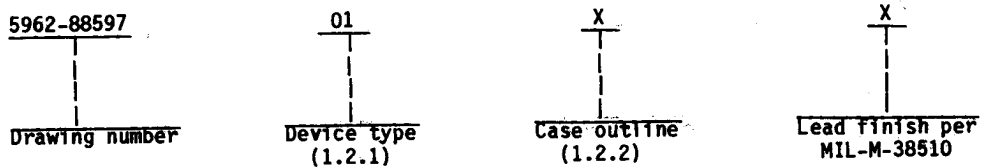

1.2.1 Device types. The device types shall identify the circuit function as follows:

<u>Device type</u>	<u>Generic number</u>	<u>Circuit function</u>
01	LT1004-1.2	Voltage reference diode
02	LT1004-2.5	Voltage reference diode

1.2.2 Case outline. The case outline shall be as designated in appendix C of MIL-M-38510, and as follows:

<u>Outline letter</u>	<u>Case outline</u>
X	T0-46, 2-lead can, (see figure 1)

1.3 Absolute maximum ratings.

Reverse current - - - - -	30 mA
Forward current - - - - -	10 mA
Storage temperature range - - - - -	-65°C to +150°C
Maximum power dissipation, (P <sub>D</sub> ) ambient - - - - -	113 mW
Lead temperature (soldering 10 seconds) - - - - -	+300°C
Thermal resistance:	
Junction-to-case (θ <sub>JC</sub> ) - - - - -	80°C/W
Junction-to-ambient (θ <sub>JA</sub> ) - - - - -	440°C/W
Junction temperature (T <sub>J</sub> ) - - - - -	175°C

1.4 Recommended operating conditions.

Ambient operating temperature range (T <sub>A</sub> ) - - - - -	-55°C to +125°C
---	-----------------

<b>STANDARDIZED MILITARY DRAWING</b> DEFENSE ELECTRONICS SUPPLY CENTER DAYTON, OHIO 45444	SIZE <b>A</b>	5962-88597
	REVISION LEVEL	SHEET 2

**2. APPLICABLE DOCUMENTS**

2.1 Government specification and standard. Unless otherwise specified, the following specification and standard, of the issue listed in that issue of the Department of Defense Index of Specifications and Standards specified in the solicitation, form a part of this drawing to the extent specified herein.

**SPECIFICATION**

**MILITARY**

MIL-M-38510 - Microcircuits, General Specification for.

**STANDARD**

**MILITARY**

MIL-STD-883 - Test Methods and Procedures for Microelectronics.

(Copies of the specification and standard required by manufacturers in connection with specific acquisition functions should be obtained from the contracting activity or as directed by the contracting activity.)

2.2 Order of precedence. In the event of a conflict between the text of this drawing and the references cited herein, the text of this drawing shall take precedence.

**3. REQUIREMENTS**

3.1 Item requirements. The individual item requirements shall be in accordance with 1.2.1 of MIL-STD-883, "Provisions for the use of MIL-STD-883 in conjunction with compliant non-JAN devices" and as specified herein.

3.2 Design, construction, and physical dimensions. The design, construction, and physical dimensions shall be as specified in MIL-M-38510 and herein.

3.2.1 Terminal connections. The terminal connections shall be as specified on figure 1.

3.2.2 Case outline. The case outline shall be in accordance with 1.2.2 herein and as specified on figure 1.

3.3 Electrical performance characteristics. Unless otherwise specified, the electrical performance characteristics are as specified in table I and apply over the full ambient operating temperature range.

3.4 Marking. Marking shall be in accordance with MIL-STD-883 (see 3.1 herein). The part shall be marked with the part number listed in 1.2 herein. In addition, the manufacturer's part number may also be marked as listed in 6.4 herein.

3.5 Certificate of compliance. A certificate of compliance shall be required from a manufacturer in order to be listed as an approved source of supply in 6.4. The certificate of compliance submitted to DESC-ECS prior to listing as an approved source of supply shall state that the manufacturer's product meets the requirements of MIL-STD-883 (see 3.1 herein) and the requirements herein.

3.6 Certificate of conformance. A certificate of conformance as required in MIL-STD-883 (see 3.1 herein) shall be provided with each lot of microcircuits delivered to this drawing.

3.7 Notification of change. Notification of change to DESC-ECS shall be required in accordance with MIL-STD-883 (see 3.1 herein).

<b>STANDARDIZED MILITARY DRAWING</b> DEFENSE ELECTRONICS SUPPLY CENTER DAYTON, OHIO 45444	SIZE <b>A</b>	5962-88597
		REVISION LEVEL

**TABLE I. Electrical performance characteristics.**

Test	Symbol	Conditions -55°C < T <sub>A</sub> < +125°C unless otherwise specified	Device type	Group A subgroups	Limits		Unit
					Min	Max	
Reverse breakdown voltage	V <sub>REF</sub>	I <sub>R</sub> = 100 μA	01	1	1.231	1.239	V
			02		2.480	2.520	
			01	2,3	1.220	1.245	
			02		2.460	2.535	
Reverse breakdown voltage change with current	ΔV <sub>REF</sub>	10 μA ≤ I <sub>R</sub> ≤ 1 mA	01	1	-1	1	mV
	ΔI <sub>R</sub>	20 μA ≤ I <sub>R</sub> ≤ 1 mA	02				
		20 μA ≤ I <sub>R</sub> ≤ 1 mA	A11	2,3	-1.5	1.5	mV
		1 mA ≤ I <sub>R</sub> ≤ 20 mA	A11	1	-10	10	mV
		1 mA ≤ I <sub>R</sub> ≤ 20 mA	A11	2,3	-20	20	mV
Forward bias voltage	V <sub>F</sub>	I <sub>F</sub> = 2 mA, T <sub>A</sub> = +25°C	A11	1	-1	-0.4	V

1.970  
1.670

<b>STANDARDIZED MILITARY DRAWING</b> DEFENSE ELECTRONICS SUPPLY CENTER DAYTON, OHIO 45444	SIZE <b>A</b>	5962-88597
	REVISION LEVEL	SHEET 4

3.8 Verification and review. DESC, DESC's agent, and the acquiring activity retain the option to review the manufacturer's facility and applicable required documentation. Offshore documentation shall be made available onshore at the option of the reviewer.

4. QUALITY ASSURANCE PROVISIONS

4.1 Sampling and inspection. Sampling and inspection procedures shall be in accordance with section 4 of MIL-M-38510 to the extent specified in MIL-STD-883 (see 3.1 herein).

4.2 Screening. Screening shall be in accordance with method 5004 of MIL-STD-883, and shall be conducted on all devices prior to quality conformance inspection. The following additional criteria shall apply:

- a. Burn-in test, method 1015 of MIL-STD-883.
  - (1) Test condition A, B, C, or D using the circuit submitted with the certificate of compliance (see 3.5 herein).
  - (2)  $T_A = +125^{\circ}\text{C}$ , minimum.
- b. Interim and final electrical test parameters shall be as specified in table II herein, except interim electrical parameter tests prior to burn-in are optional at the discretion of the manufacturer.

4.3 Quality conformance inspection. Quality conformance inspection shall be in accordance with method 5005 of MIL-STD-883 including groups A, B, C, and D inspections. The following additional criteria shall apply.

4.3.1 Group A inspection.

- a. Tests shall be as specified in table II herein.
- b. Subgroups 4, 5, 6, 7, 8, 9, 10, and 11 of method 5005 of MIL-STD-883 shall be omitted.

4.3.2 Groups C and D inspections.

- a. End-point electrical parameters shall be as specified in table II herein.
- b. Steady-state life test conditions, method 1005 of MIL-STD-883:
  - (1) Test condition A, B, C, or D using the circuit submitted with the certificate of compliance (see 3.5 herein).
  - (2)  $T_A = +125^{\circ}\text{C}$ , minimum.
  - (3) Test duration: 1,000 hours, except as permitted by method 1005 of MIL-STD-883.

<b>STANDARDIZED MILITARY DRAWING</b> DEFENSE ELECTRONICS SUPPLY CENTER DAYTON, OHIO 45444	SIZE <b>A</b>	5962-88597
	REVISION LEVEL	SHEET 5

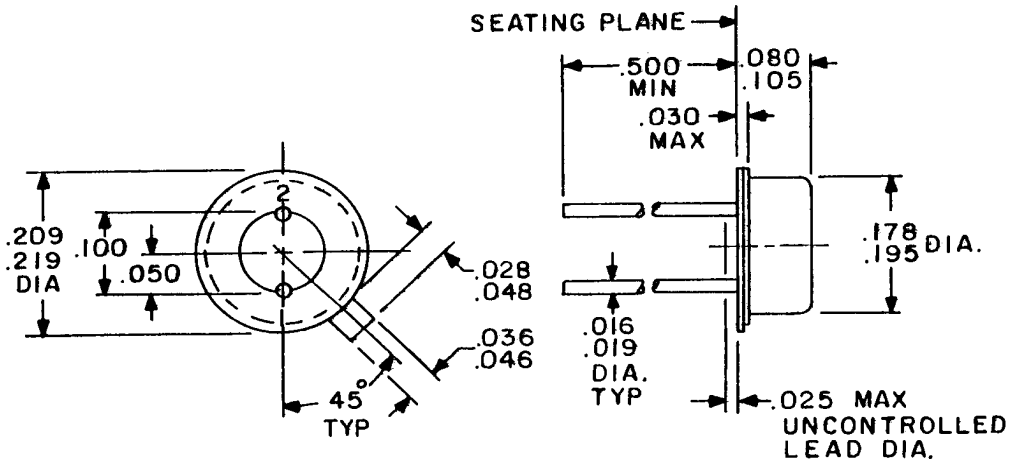

METAL CAN PACKAGE

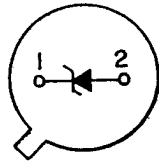

BOTTOM VIEW

Inches	mm	Inches	mm
.016	0.41	.080	2.03
.019	0.48	.100	2.54
.025	0.64	.105	2.67
.028	0.28	.178	4.52
.030	0.76	.195	4.95
.036	0.91	.209	5.31
.046	1.17	.219	5.56
.048	1.22	.500	12.70
.050	1.27		

NOTES:

1. Dimensions are in inches.
2. Metric equivalents are given for general information only.

FIGURE 1. Case outline and terminal connections.

<b>STANDARDIZED MILITARY DRAWING</b> DEFENSE ELECTRONICS SUPPLY CENTER DAYTON, OHIO 45444	SIZE <b>A</b>	5962-88597
	REVISION LEVEL	SHEET 6

TABLE II. Electrical test requirements.

MIL-STD-883 test requirements	Subgroups (per method 5005, table I)
Interim electrical parameters (method 5004)	---
Final electrical test parameters (method 5004)	1*,2,3
Group A test requirements (method 5005)	1,2,3
Groups C and D end-point electrical parameters (method 5005)	1,2,3

\* PDA applies to subgroup 1.

5. PACKAGING

5.1 Packaging requirements. The requirements for packaging shall be in accordance with MIL-M-38510.

6. NOTES

6.1 Intended use. Microcircuits conforming to this drawing are intended for use when military specifications do not exist and qualified military devices that will perform the required function are not available for OEM application. When a military specification exists and the product covered by this drawing has been qualified for listing on QPL-38510, the device specified herein will be inactivated and will not be used for new design. The QPL-38510 product shall be the preferred item for all applications.

6.2 Replaceability. Microcircuits covered by this drawing will replace the same generic device covered by a contractor-prepared specification or drawing.

6.3 Comments. Comments on this drawing should be directed to DESC-ECS, Dayton, Ohio 45444, or telephone 513-296-5375.

<b>STANDARDIZED MILITARY DRAWING</b> DEFENSE ELECTRONICS SUPPLY CENTER DAYTON, OHIO 45444	SIZE <b>A</b>	5962-88597
	REVISION LEVEL	SHEET 7

查询"5962-8859702XX"供应商

6.4 Approved source of supply. An approved source of supply is listed herein. Additional sources will be added as they become available. The vendor listed herein has agreed to this drawing and a certificate of compliance (see 3.5 herein) has been submitted to DESC-ECS.

Military drawing part number	Vendor CAGE number	Vendor similar part number <u>1/</u>
5962-8859701XX	64155	LT1004MH-1.2/883
5962-8859702XX	64155	LT1004MH-2.5/883

1/ Caution. Do not use this number for item acquisition. Items acquired to this number may not satisfy the performance requirements of this drawing.

Vendor CAGE number

64155

Vendor name and address

Linear Technology Corporation  
1630 McCarthy Boulevard  
Milpitas, CA 95035-7487

<b>STANDARDIZED MILITARY DRAWING</b> DEFENSE ELECTRONICS SUPPLY CENTER DAYTON, OHIO 45444	SIZE <b>A</b>	5962-88597
	REVISION LEVEL	SHEET 8

DESC FORM 193A  
SEP 87

\* U. S. GOVERNMENT PRINTING OFFICE: 1988-648-904

011108 ✓ \_ \_ \_