

LBT7003L SAW Filter Electrical Characteristic

Specifications

Parameter	Unit	Minimum	Typical	Maximum
Center Frequency	MHz	69.95	70	70.05
Insertion Loss	dB		12.2	14
3 dB Bandwidth	MHz	1.50	1.64	
40 dB Bandwidth	MHz		3.12	3.3
Passband variation	dB		0.2	1
Ultimate Rejection	dB	45	50	
Substrate Material		112 ⁰ -LiTaO ₃		
Ambient Temperature	°C	25		
Package Size		SMP-75 (19x6.5x2.0mm ³)		

Typical Performance

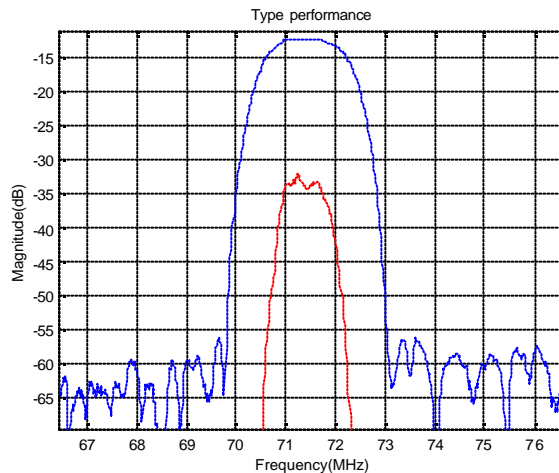

Package Outline

Matching Configuration

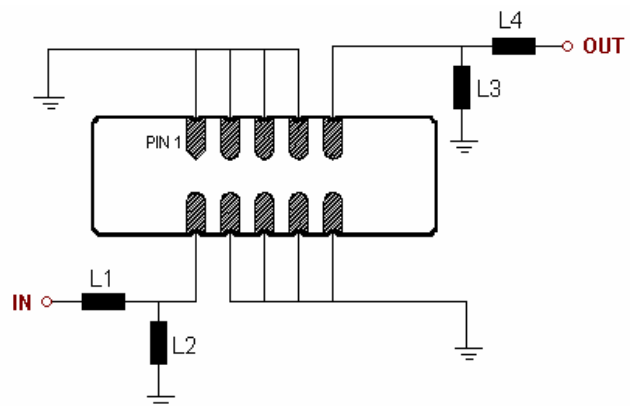
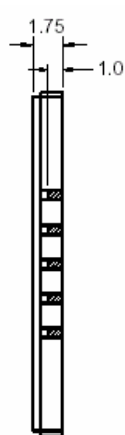
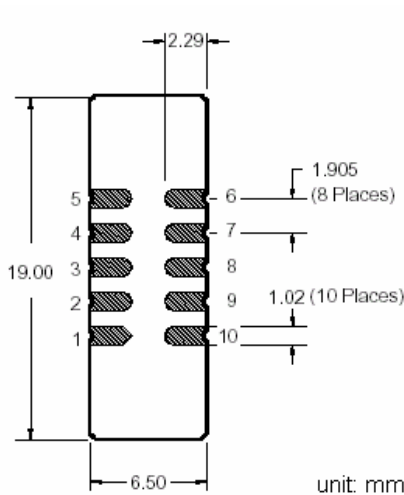

L1=150nH L2=220nH L3=180nH L4=112nH

Source/Load Impedance = 50 ohm