

HD74LVC16245A

16-bit Bus Transceivers with 3-state Outputs

HITACHI

ADE-205-120B(Z)
3rd Edition
December 1996

Description

The HD74LVC16245A has sixteen two direction buffers, for the fittest at two direction bus lines with three state outputs. A direction control input, DIR. When DIR is high, data flows from the A inputs to the B outputs. When DIR is low, data flows from the B inputs to the A outputs. When enable inputs (\bar{G}) is high, disables both A and B ports by placing them in a high impedance. Low voltage and high speed operation is suitable at the battery drive product (note type personal computer) and low power consumption extends the life of a battery for long time operation.

Features

- $V_{CC} = 2.0\text{ V to }5.5\text{ V}$
- All inputs $V_{IH}(\text{Max.}) = 5.5\text{ V} (@V_{CC} = 0\text{ V to }5.5\text{ V})$
- All outputs $V_{OUT}(\text{Max.}) = 5.5\text{ V} (@V_{CC} = 0\text{ V or output off state})$
- Typical V_{OL} ground bounce $< 0.8\text{ V} (@V_{CC} = 3.3\text{ V, Ta} = 25^\circ\text{C})$
- Typical V_{OH} undershoot $> 2.0\text{ V} (@V_{CC} = 3.3\text{ V, Ta} = 25^\circ\text{C})$
- High output current $\pm 24\text{ mA} (@V_{CC} = 3.0\text{ V to }5.5\text{ V})$

Function Table

Inputs		Operation
\bar{G}	DIR	
L	L	B data to A bus
L	H	A data to B bus
H	X	Z

H: High level
L: Low level
X: Immaterial
Z: High impedance

HD74LVC16245A

Pin Arrangement

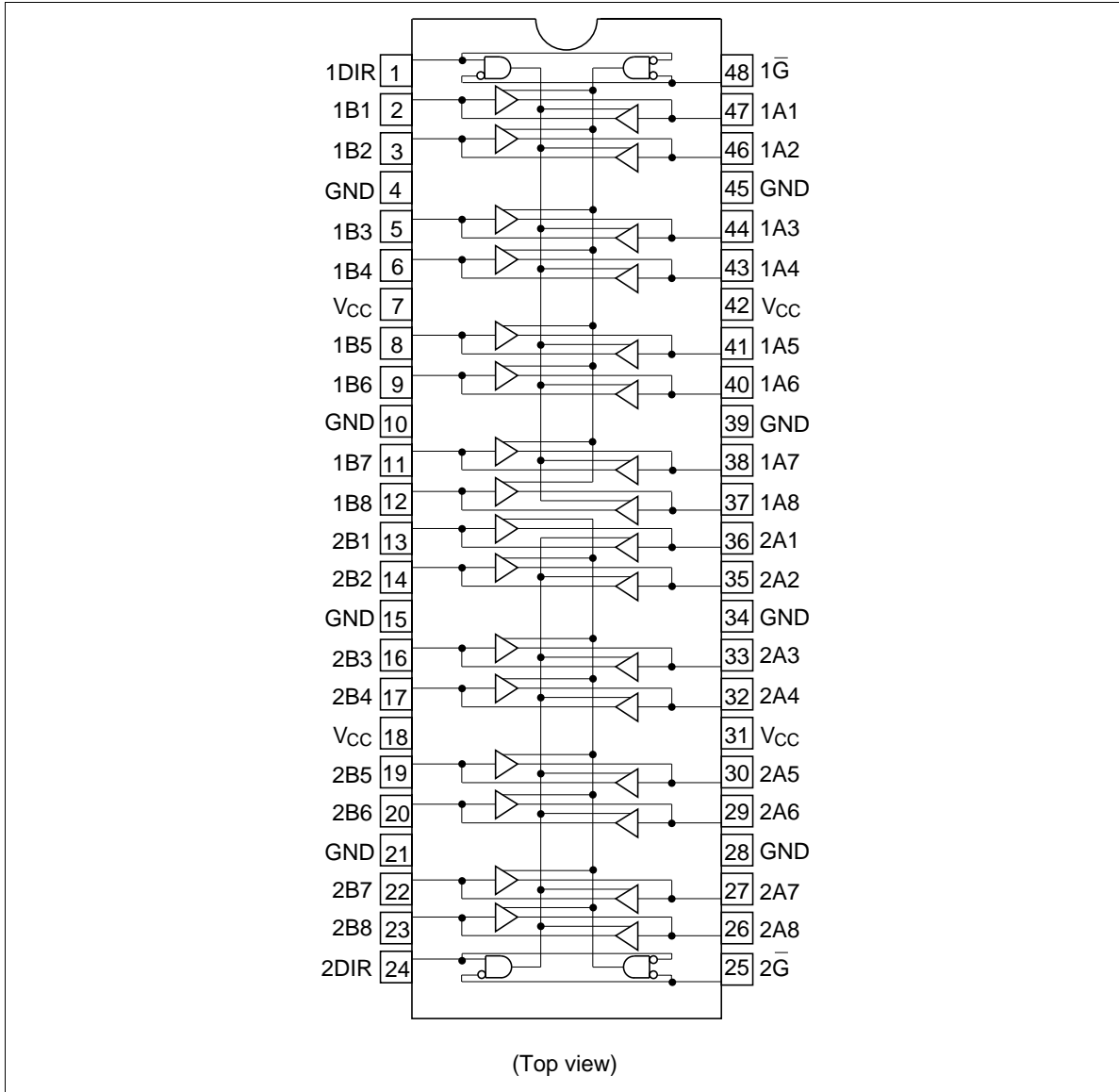

Absolute Maximum Ratings

Item	Symbol	Ratings	Unit	Conditions
Supply voltage	V_{CC}	-0.5 to 6.0	V	
Input diode current	I_{IK}	-50	mA	$V_I = -0.5\text{ V}$
Input voltage	V_I	-0.5 to 6.0	V	\bar{G} , DIR
Output diode current	I_{OK}	-50	mA	$V_O = -0.5\text{ V}$
		50	mA	$V_O = V_{CC} + 0.5\text{ V}$
Input / Output voltage	V_{IO}	-0.5 to $V_{CC} + 0.5$	V	Output "H" or "L"
		-0.5 to 6.0	V	Output "Z" or V_{CC} :OFF
Output current	I_O	± 50	mA	
V_{CC} , GND current / pin	I_{CC} or I_{GND}	100	mA	
Storage temperature	Tstg	-65 to +150	°C	

Note: The absolute maximum ratings are values which must not individually be exceeded, and furthermore, no two of which may be realized at the same time.

Recommended Operating Conditions

Item	Symbol	Ratings	Unit	Conditions	
Supply voltage	V_{CC}	1.5 to 5.5	V	Data retention	
		2.0 to 5.5	V	At operation	
Input / output voltage	V_I	0 to 5.5	V	\bar{G} , DIR	
		V_{IO}	0 to V_{CC}	V	Output "H" or "L"
			0 to 5.5	V	Output "Z" or V_{CC} :OFF
Operating temperature	Ta	-40 to 85	°C		
Output current	I_{OH}	-12	mA	$V_{CC} = 2.7\text{ V}$	
		-24^{*2}	mA	$V_{CC} = 3.0\text{ V to } 5.5\text{ V}$	
	I_{OL}	12	mA	$V_{CC} = 2.7\text{ V}$	
		24^{*2}	mA	$V_{CC} = 3.0\text{ V to } 5.5\text{ V}$	
Input rise / fall time ^{*1}	t_r, t_f	10	ns/V		

Notes: 1. This item guarantees maximum limit when one input switches.

Waveform : Refer to test circuit of switching characteristics.

2. duty cycle $\leq 50\%$

HD74LVC16245A

Electrical Characteristics

Item	Symbol	V _{CC} (V)	Ta = -40 to 85°C		Unit	Test Conditions
			Min	Max		
Input voltage	V _{IH}	2.7 to 3.6	2.0	—	V	
		4.5 to 5.5	V _{CC} ×0.7	—	V	
	V _{IL}	2.7 to 3.6	—	0.8	V	
		4.5 to 5.5	—	V _{CC} ×0.3	V	
Output voltage	V _{OH}	2.7 to 5.5	V _{CC} -0.2	—	V	I _{OH} = -100 μA
		2.7	2.2	—	V	I _{OH} = -12 mA
		3.0	2.4	—	V	
		3.0	2.2	—	V	I _{OH} = -24 mA
		4.5	3.8	—	V	
	V _{OL}	2.7 to 5.5	—	0.2	V	I _{OL} = 100 μA
		2.7	—	0.4	V	I _{OL} = 12 mA
		3.0	—	0.55	V	I _{OL} = 24 mA
		4.5	—	0.55	V	
Input current	I _{IN}	0 to 5.5	—	±5.0	μA	V _{IN} = 5.5 V or GND
Off state output current	I _{OZ}	2.7 to 5.5	—	±5.0	μA	V _{IN} = V _{CC} , GND V _{OUT} = 5.5 V or GND
Output leak current	I _{OFF}	0	—	20	μA	V _{IN} / V _{OUT} = 5.5 V
Quiescent supply current	I _{CC}	2.7 to 3.6	—	±20	μA	V _{IN} / V _{OUT} = 3.6 to 5.5 V
		2.7 to 5.5	—	20	μA	V _{IN} = V _{CC} or GND
	ΔI _{CC}	3.0 to 3.6	—	500	μA	V _{IN} = one input at (V _{CC} -0.6)V, other inputs at V _{CC} or GND

Switching Characteristics

Item	Symbol	V _{CC} (V)	Ta = -40 to 85°C			Unit	From (Input)	To (Output)
			Min	Typ	Max			
Propagation delay time	t _{PLH}	2.7	—	—	5.8	ns	A or B	B or A
	t _{PHL}	3.3±0.3	1.5	—	5.2	ns		
		5.0±0.5	—	—	4.5	ns		
Output enable time	t _{ZH}	2.7	—	—	8.0	ns	\bar{G}	B or A
	t _{ZL}	3.3±0.3	1.5	—	7.2	ns		
		5.0±0.5	—	—	6.0	ns		
Output disable time	t _{HZ}	2.7	—	—	8.0	ns	\bar{G}	B or A
	t _{LZ}	3.3±0.3	1.5	—	7.2	ns		
		5.0±0.5	—	—	6.0	ns		
Between output pins skew ^{*1}	t _{OSLH}	2.7	—	—	—	ns		
	t _{OSHL}	3.3±0.3	—	—	1.0	ns		
		5.0±0.5	—	—	1.0	ns		
Input capacitance	C _{IN}	2.7	—	3.0	—	pF		
Output capacitance	C _O	2.7	—	15.0	—	pF		

Note: 1. This parameter is characterized but not tested.

$$tos_{LH} = |t_{PLHm} - t_{PLHn}|, tos_{HL} = |t_{PHLm} - t_{PHLn}|$$

HD74LVC16245A

Test Circuit

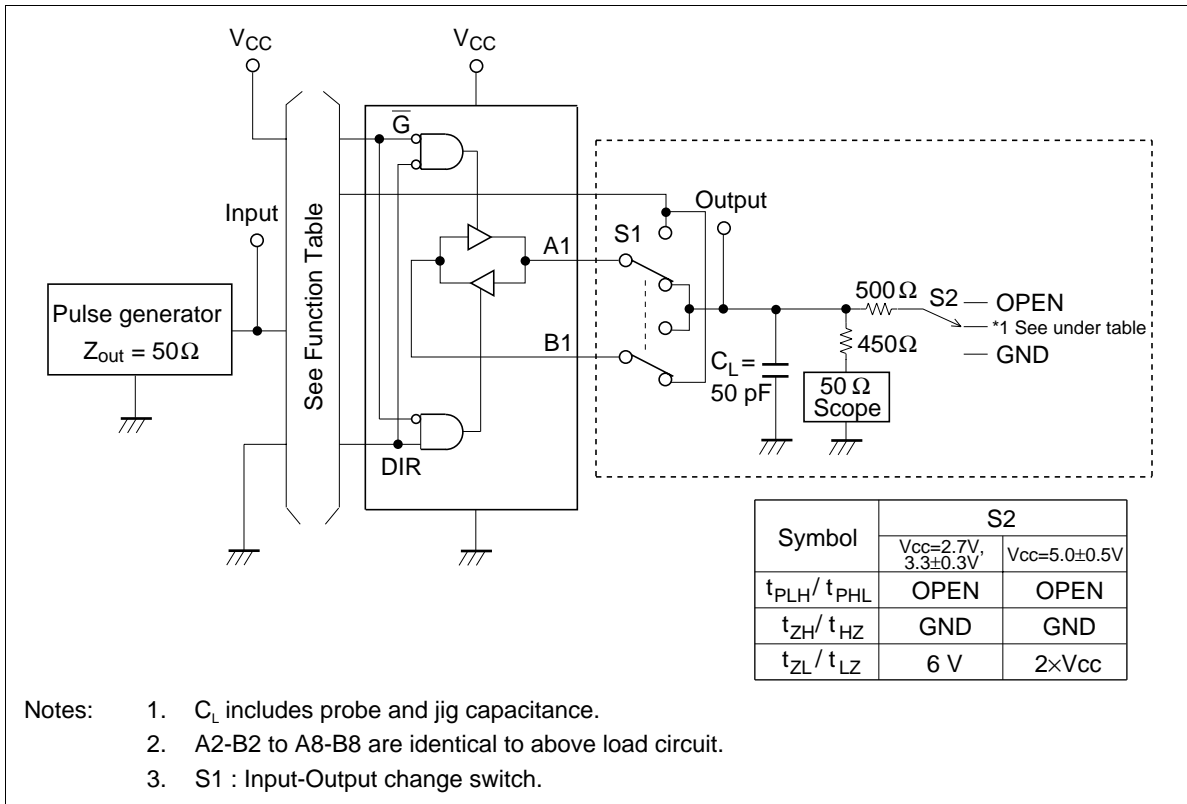

Waveforms – 1

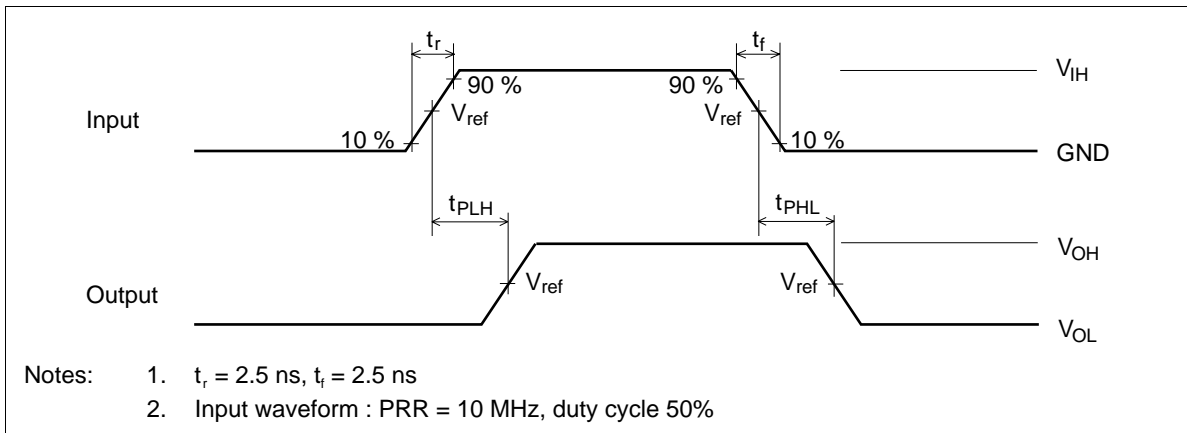

Waveforms – 2

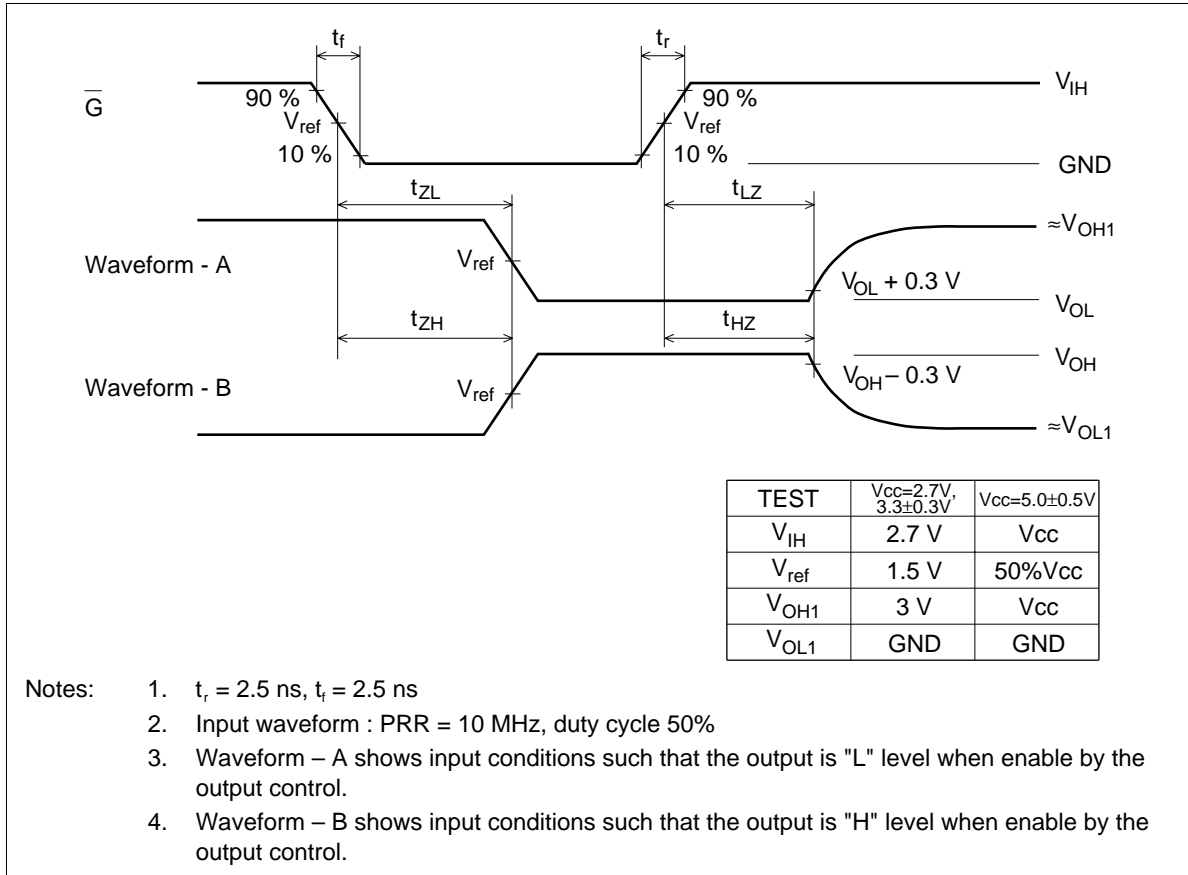

[查询"HD74LVC16245A"供应商](#)

Unit: mm

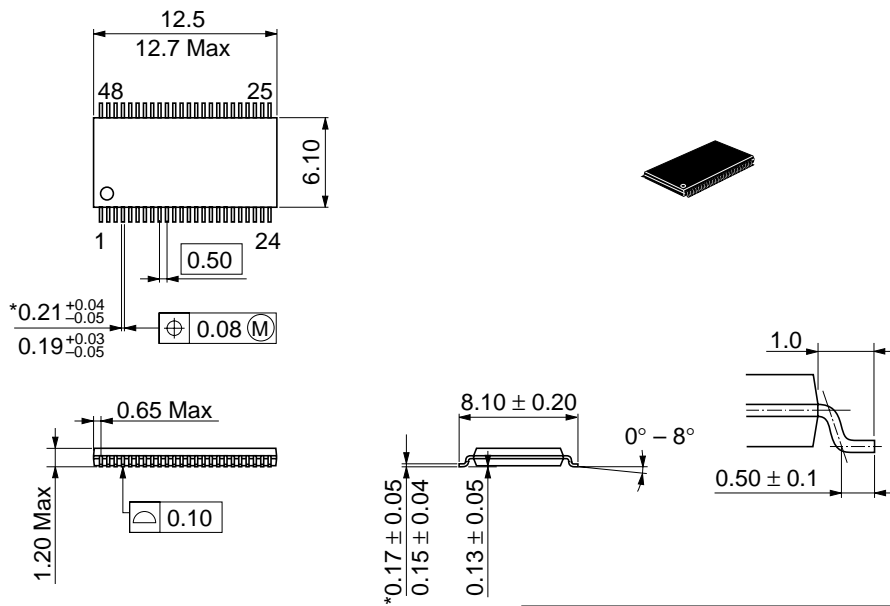

*Dimension including the plating thickness
Base material dimension

Hitachi Code	TTP-48DB
JEDEC	—
EIAJ	—
Weight (reference value)	0.20 g

Cautions

1. Hitachi neither warrants nor grants licenses of any rights of Hitachi's or any third party's patent, copyright, trademark, or other intellectual property rights for information contained in this document. Hitachi bears no responsibility for problems that may arise with third party's rights, including intellectual property rights, in connection with use of the information contained in this document.
2. Products and product specifications may be subject to change without notice. Confirm that you have received the latest product standards or specifications before final design, purchase or use.
3. Hitachi makes every attempt to ensure that its products are of high quality and reliability. However, contact Hitachi's sales office before using the product in an application that demands especially high quality and reliability or where its failure or malfunction may directly threaten human life or cause risk of bodily injury, such as aerospace, aeronautics, nuclear power, combustion control, transportation, traffic, safety equipment or medical equipment for life support.
4. Design your application so that the product is used within the ranges guaranteed by Hitachi particularly for maximum rating, operating supply voltage range, heat radiation characteristics, installation conditions and other characteristics. Hitachi bears no responsibility for failure or damage when used beyond the guaranteed ranges. Even within the guaranteed ranges, consider normally foreseeable failure rates or failure modes in semiconductor devices and employ systemic measures such as fail-safes, so that the equipment incorporating Hitachi product does not cause bodily injury, fire or other consequential damage due to operation of the Hitachi product.
5. This product is not designed to be radiation resistant.
6. No one is permitted to reproduce or duplicate, in any form, the whole or part of this document without written approval from Hitachi.
7. Contact Hitachi's sales office for any questions regarding this document or Hitachi semiconductor products.

HITACHI

Hitachi, Ltd.

Semiconductor & Integrated Circuits.
Nippon Bldg., 2-6-2, Ohte-machi, Chiyoda-ku, Tokyo 100-0004, Japan
Tel: Tokyo (03) 3270-2111 Fax: (03) 3270-5109

URL NorthAmerica : <http://semiconductor.hitachi.com/>
Europe : <http://www.hitachi-eu.com/hel/ecg>
Asia (Singapore) : <http://www.has.hitachi.com.sg/grp3/sicd/index.htm>
Asia (Taiwan) : http://www.hitachi.com.tw/E/Product/SICD_Frame.htm
Asia (HongKong) : <http://www.hitachi.com.hk/eng/bo/grp3/index.htm>
Japan : <http://www.hitachi.co.jp/Sicd/indx.htm>

For further information write to:

Hitachi Semiconductor
(America) Inc.
179 East Tasman Drive,
San Jose, CA 95134
Tel: <1> (408) 433-1990
Fax: <1> (408) 433-0223

Hitachi Europe GmbH
Electronic components Group
Dornacher StraÙe 3
D-85622 Feldkirchen, Munich
Germany
Tel: <49> (89) 9 9180-0
Fax: <49> (89) 9 29 30 00

Hitachi Europe Ltd.
Electronic Components Group.
Whitebrook Park
Lower Cookham Road
Maidenhead
Berkshire SL6 8YA, United Kingdom
Tel: <44> (1628) 585000
Fax: <44> (1628) 778322

Hitachi Asia Pte. Ltd.
16 Collyer Quay #20-00
Hitachi Tower
Singapore 049318
Tel: 535-2100
Fax: 535-1533

Hitachi Asia Ltd.
Taipei Branch Office
3F, Hung Kuo Building, No.167,
Tun-Hwa North Road, Taipei (105)
Tel: <886> (2) 2718-3666
Fax: <886> (2) 2718-8180

Hitachi Asia (Hong Kong) Ltd.
Group III (Electronic Components)
7/F., North Tower, World Finance Centre,
Harbour City, Canton Road, Tsim Sha Tsui,
Kowloon, Hong Kong
Tel: <852> (2) 735 9218
Fax: <852> (2) 730 0281
Telex: 40815 HITEC HX

Copyright ' Hitachi, Ltd., 1999. All rights reserved. Printed in Japan.