

查询"LM032L"供应商

# LM032L·LM032XMBL

- 20 character x 2 lines
- Controller LSI HD44780 is built-in (See page 79).
- +5V single power supply
- Display color: LM032L : Gray  
LM032XMBL : New-gray

## MECHANICAL DATA (Nominal dimensions)

Module size . . . . .116W x 39H (max.) x 10.5T (max.) mm  
 Effective display area . . . . . 83W x 18.6H mm  
 Character size (5 x 7 dots) . . . . . 3.2W x 4.85H mm  
 Character pitch . . . . . 3.7 mm  
 Dot size . . . . . 0.6W x 0.65H mm  
 Weight . . . . . about 50 g

## ABSOLUTE MAXIMUM RATINGS

	min.	max.
Power supply for logic ( $V_{DD}-V_{SS}$ ) . . . . .	0	6.5 V
Power supply for LCD drive ( $V_{DD}-V_O$ ) . . . . .	0	6.5 V
Input voltage ( $V_i$ ) . . . . .	$V_{SS}$	$V_{DD}$ V
Operating temperature ( $T_a$ ) . . . . .	0	50 40*°C
Storage temperature ( $T_{stg}$ ) . . . . .	-20	70 60*°C

\* Shows the value of type LM032XMBL.

## ELECTRICAL CHARACTERISTICS

$T_a = 25^\circ\text{C}$ ,  $V_{DD} = 5.0 \text{ V} \pm 0.25 \text{ V}$

Input "high" voltage ( $V_{IH}$ ) . . . . .	2.2 V min.
Input "low" voltage ( $V_{IL}$ ) . . . . .	0.6 V max.
Output "high" voltage ( $V_{OH}$ ) ( $-I_{OH} = 0.2 \text{ mA}$ ) . . . . .	2.4V min.
Output "low" voltage ( $V_{OL}$ ) ( $I_{OL} = 1.2 \text{ mA}$ ) . . . . .	0.4V max.
Power supply current ( $I_{DD}$ ) ( $V_{DD} = 5.0 \text{ V}$ ) . . . . .	2.0 mA typ. 3.0 mA max.

## POWER SUPPLY FOR LCD DRIVE (Recommended) ( $V_{DD}-V_O$ )

Duty = 1/16

Range of $V_{DD}-V_O$ . . . . .	1.5~5.25 V
$T_a = 0^\circ\text{C}$ . . . . .	4.6 V typ.
$T_a = 25^\circ\text{C}$ . . . . .	4.2 V typ.
$T_a = 50^\circ\text{C}$ . . . . .	3.5 V typ.

OPTICAL DATA . . . . . See page 7

## INTERNAL PIN CONNECTION

Pin No.	Symbol	Level	Function
1	$V_{SS}$	—	0V
2	$V_{DD}$	—	+5V
3	$V_O$	—	—
4	RS	H/L	L: Instruction code input H: Data input
5	R/W	H/L	H: Data read (LCD module→MPU) L: Data write (LCD module←MPU)
6	E	H, H→L	Enable signal
7	DB0	H/L	Data bus line Note (1), (2)
8	DB1	H/L	
9	DB2	H/L	
10	DB3	H/L	
11	DB4	H/L	
12	DB5	H/L	
13	DB6	H/L	
14	DB7	H/L	

### Notes:

In the HD44780, the data can be sent in either 4-bit 2-operation or 8-bit 1-operation so that it can interface to both 4 and 8 bit MPU's.

- (1) When interface data is 4 bits long, data is transferred using only 4 buses of  $DB_4 \sim DB_7$ , and  $DB_0 \sim DB_3$  are not used. Data transfer between the HD44780 and the MPU completes when 4-bit data is transferred twice. Data of the higher order 4 bits (contents of  $DB_4 \sim DB_7$ , when interface data is 8 bits long) is transferred first and then lower order 4 bits (contents of  $DB_0 \sim DB_3$ , when interface data is 8 bits long).
- (2) When interface data is 8 bits long, data is transferred using 8 data buses of  $DB_0 \sim DB_7$ .

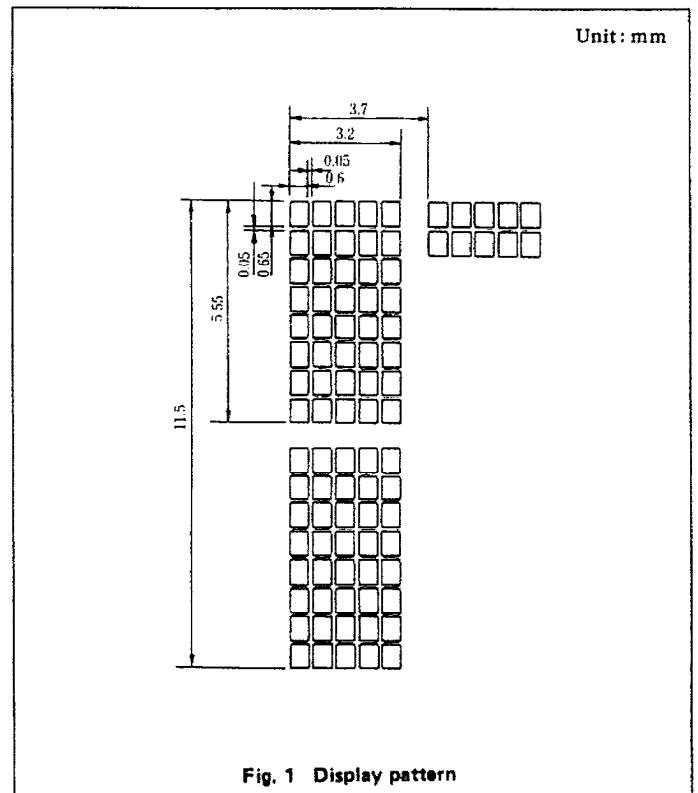
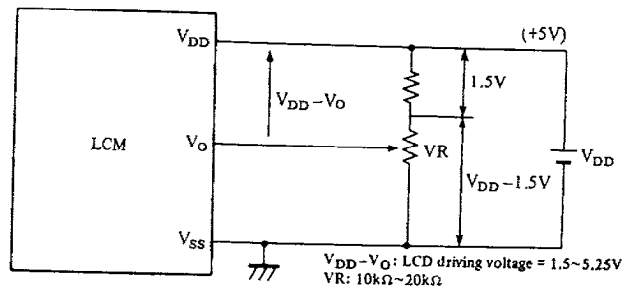
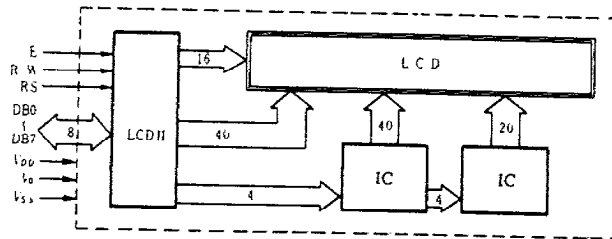
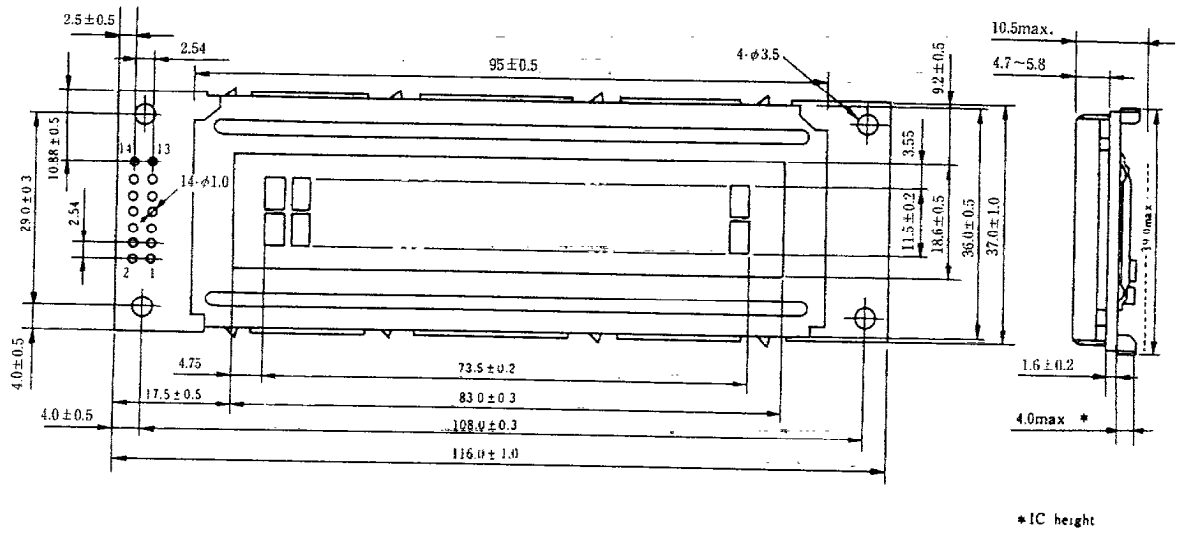

Fig. 1 Display pattern

Unit: mm



查询"LM032L"供应商

### TIMING CHARACTERISTICS

Item	Symbol	Test condition	Min.	Typ.	Max.	Unit
Enable cycle time	$t_{cyc}$	Fig. 5, Fig. 6	1.0	—	—	$\mu s$
Enable pulse width	$P_{WEH}$	Fig. 5, Fig. 6	450	—	—	ns
Enable rise/fall time	$t_{Er}, t_{Ef}$	Fig. 5, Fig. 6	—	—	25	ns
RS, R/W set up time	$t_{AS}$	Fig. 5, Fig. 6	140	—	—	ns
Data delay time	$t_{DDR}$	Fig. 6	—	—	320	ns
Data set up time	$t_{DSW}$	Fig. 5	195	—	—	ns
Hold time	$t_H$	Fig. 5, Fig. 6	20	—	—	ns

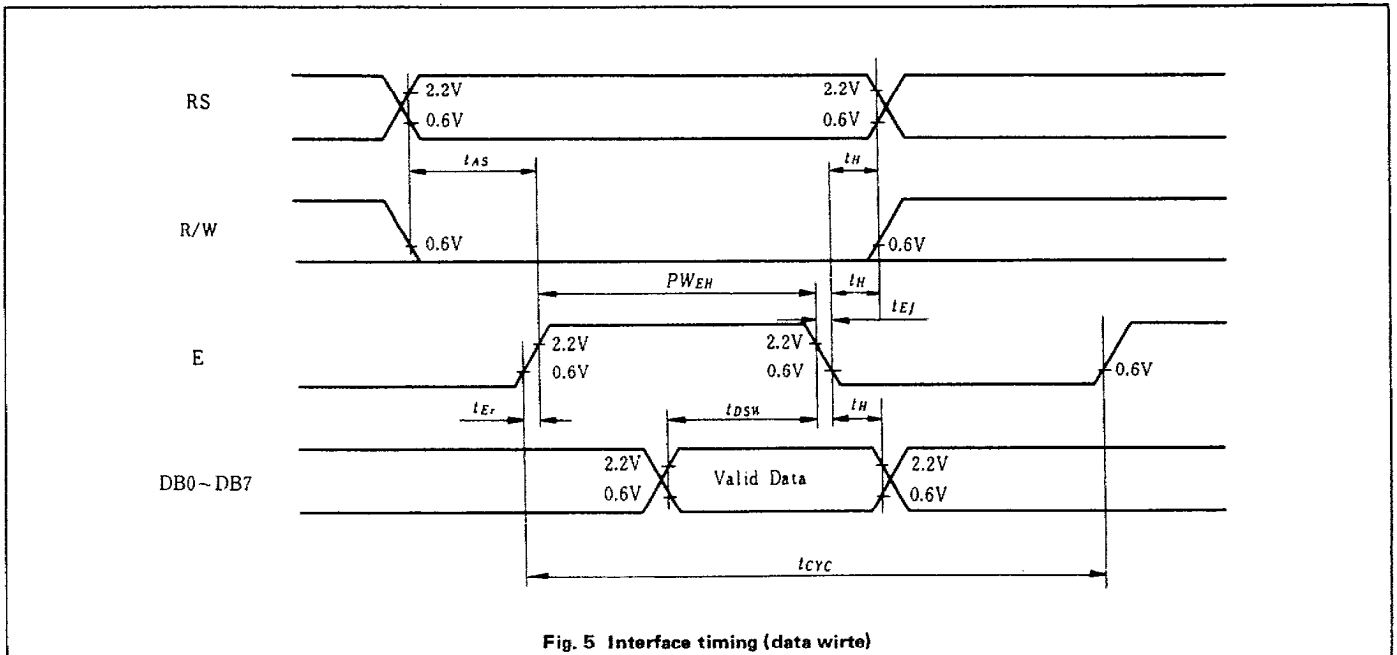

Fig. 5 Interface timing (data write)

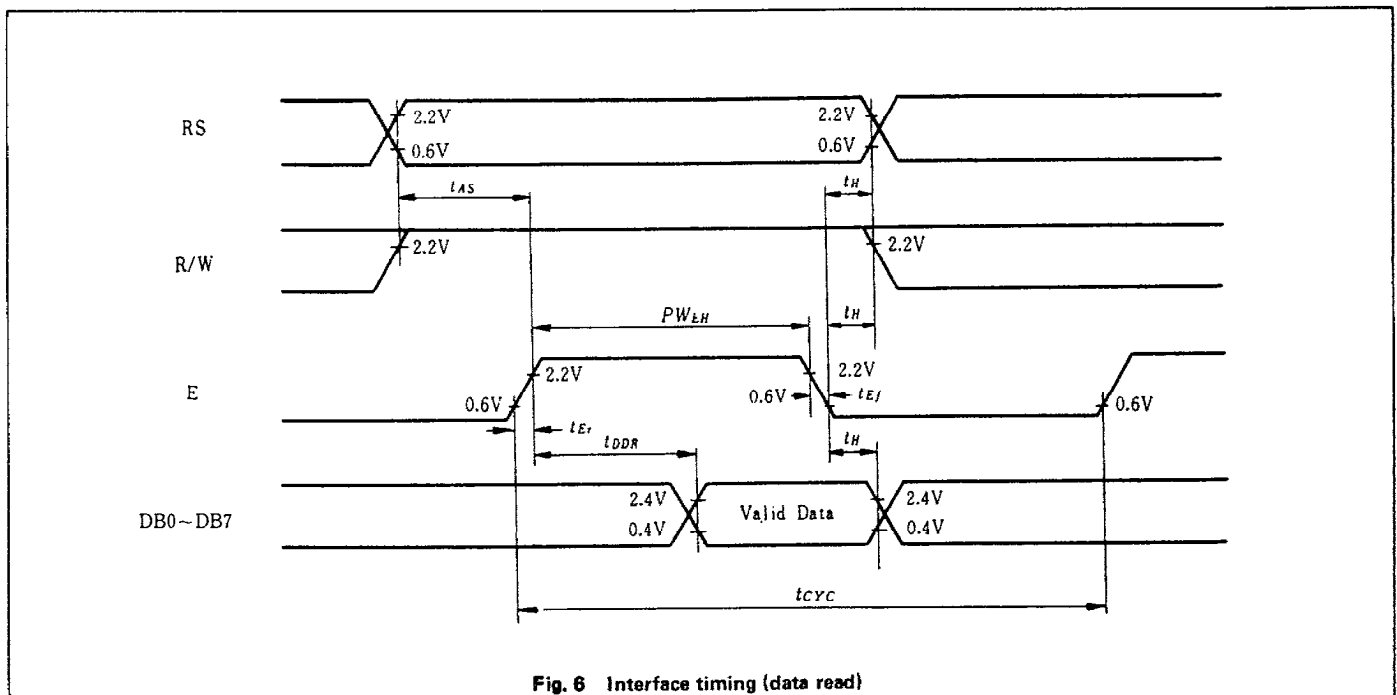

Fig. 6 Interface timing (data read)