

Positive voltage regulators

Features

- Output current to 0.5 A
- Output voltages of 5; 6; 8; 9; 12; 15; 18; 24 V
- Thermal overload protection
- Short circuit protection
- Output transition SOA protection

Description

The L78Mxx series of three-terminal positive regulators is available in TO-220, TO-220FP, DPAK and IPAK packages and with several fixed output voltages, making it useful in a wide range of applications. These regulators can provide local on-card regulation, eliminating the distribution problems associated with single point regulation. Each type employs internal current limiting, thermal shut-down and safe area protection, making it essentially indestructible. If adequate heat sinking is provided, they can deliver over 0.5 A output current. Although designed primarily as fixed voltage regulators, these devices can be used with external components to obtain adjustable voltage and currents.

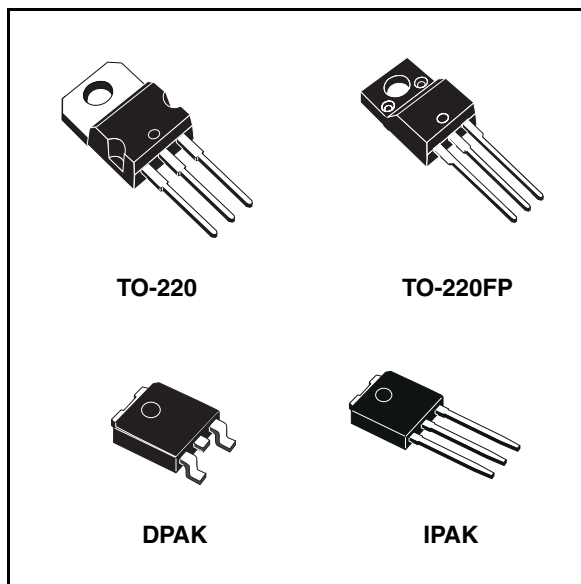

Table 1. Device summary

Part numbers	
L78M05C	L78M12C
L78M06C	L78M15C
L78M08C	L78M18C
L78M09C	L78M24C

[查询"L78MXXC"供应商](#)

Contents

1	Diagram	3
2	Pin configuration	4
3	Maximum ratings	5
4	Test circuits	6
5	Electrical characteristics	7
6	Typical performance	11
7	Package mechanical data	17
8	Order codes	27
9	Revision history	28

[查询"L78MXXC"供应商](#)
1 Diagram

Figure 1. Block diagram

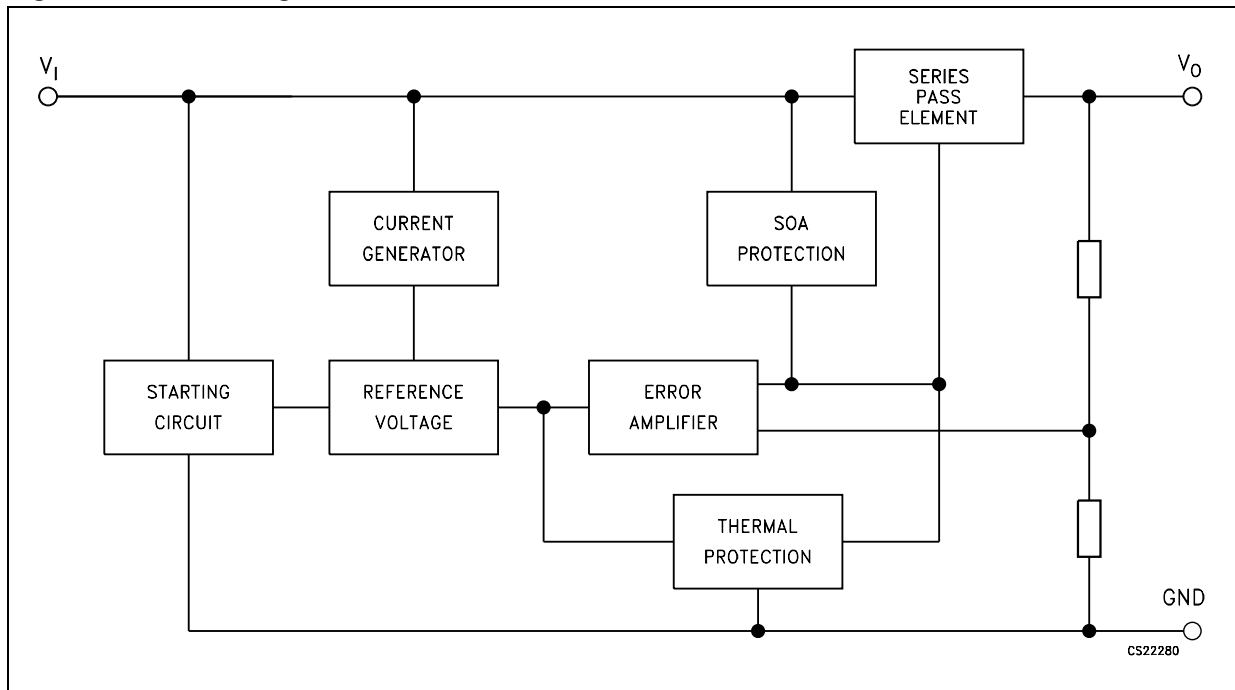

[查询"L78MXXC"供应商](#)

2 Pin configuration

Figure 2. Pin connections (top view)

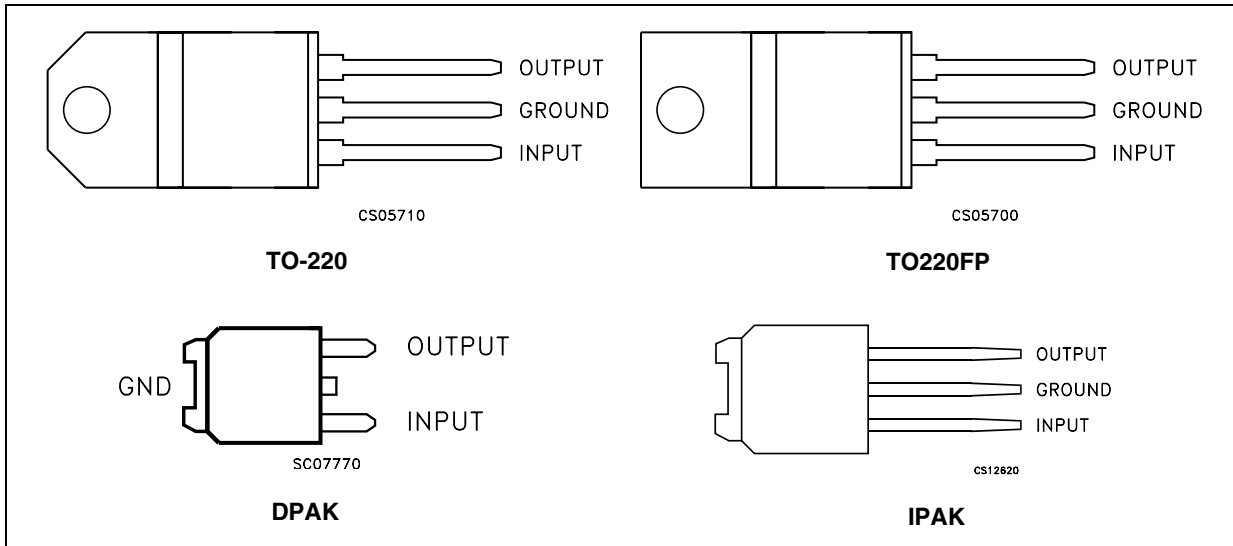
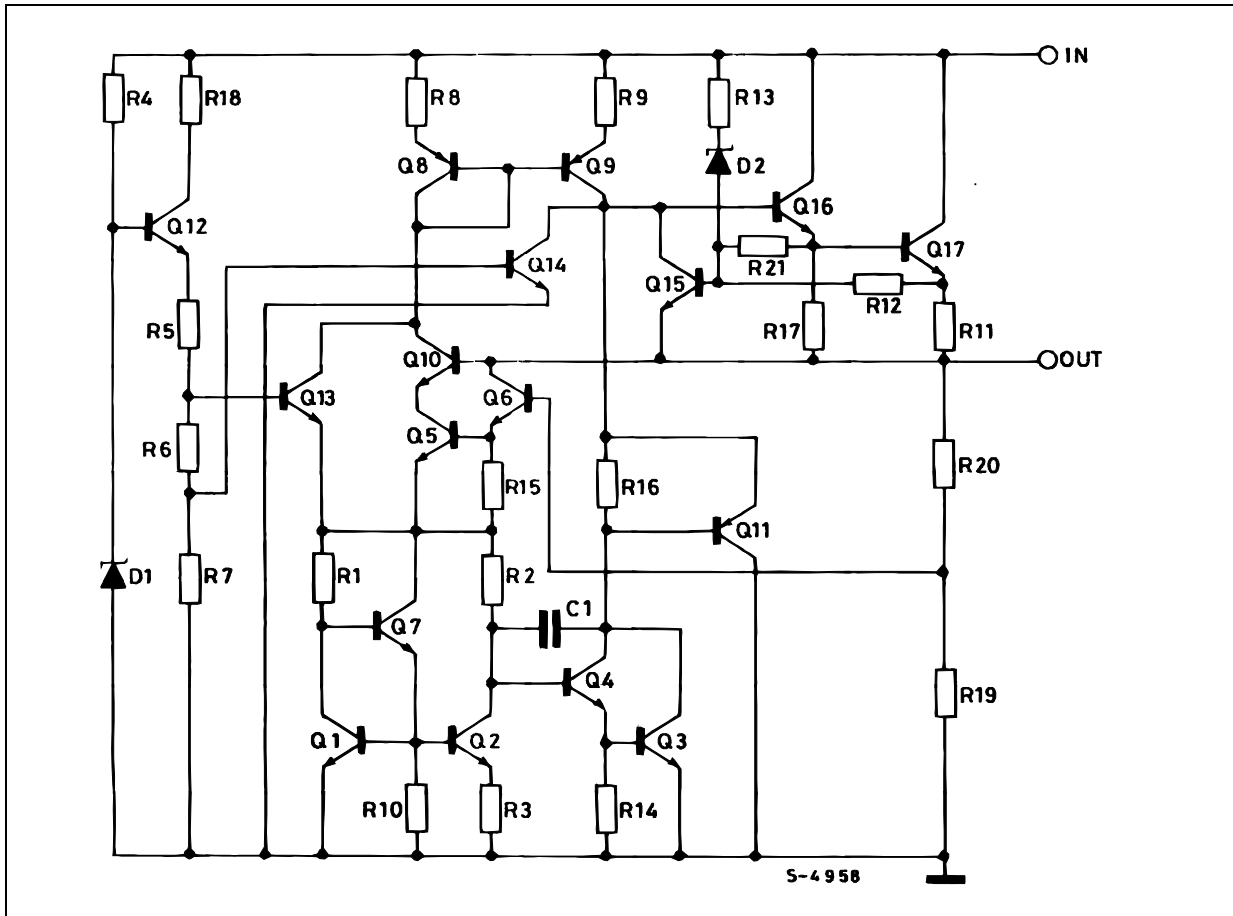

Figure 3. Schematic diagram



[查询"L78MXXC"供应商](#)

3 Maximum ratings

Table 2. Absolute maximum ratings

Symbol	Parameter	Value	Unit
V_I	DC input voltage	for $V_O = 5$ to $18V$	35
		for $V_O = 20, 24V$	40
I_O	Output current	Internally limited	mA
P_D	Power dissipation	Internally limited	mW
T_{STG}	Storage temperature range	-65 to 150	°C
T_{OP}	Operating junction temperature range	0 to 150	°C

Note: Absolute maximum ratings are those values beyond which damage to the device may occur. Functional operation under these condition is not implied

Table 3. Thermal data

Symbol	Parameter	TO-220	TO-220FP	DPAK	IPAK	Unit
R_{thJC}	Thermal resistance junction-case	3	5	8		°C/W
R_{thJA}	Thermal resistance junction-ambient	50	60	100		°C/W

Figure 4. Application circuits

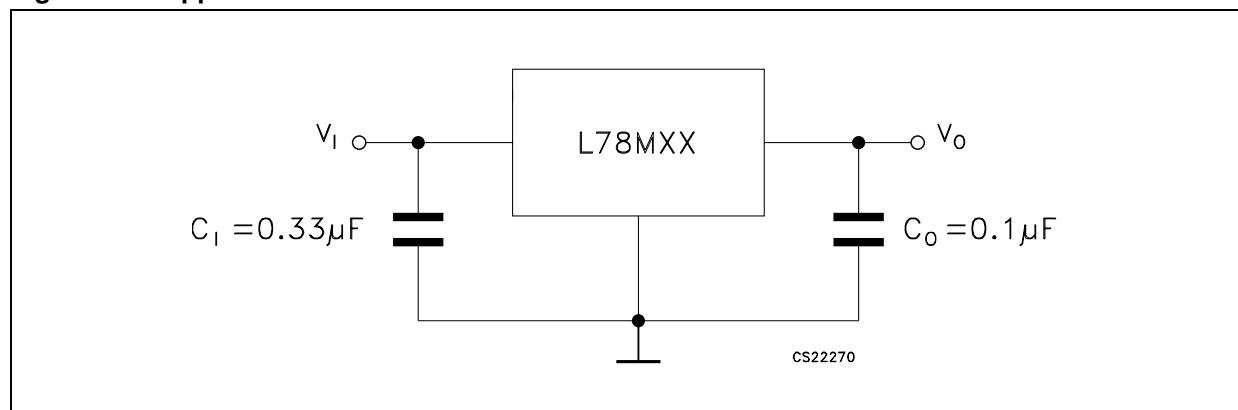

[查询"L78MXXC"供应商](#)

4 Test circuits

Figure 5. DC parameter

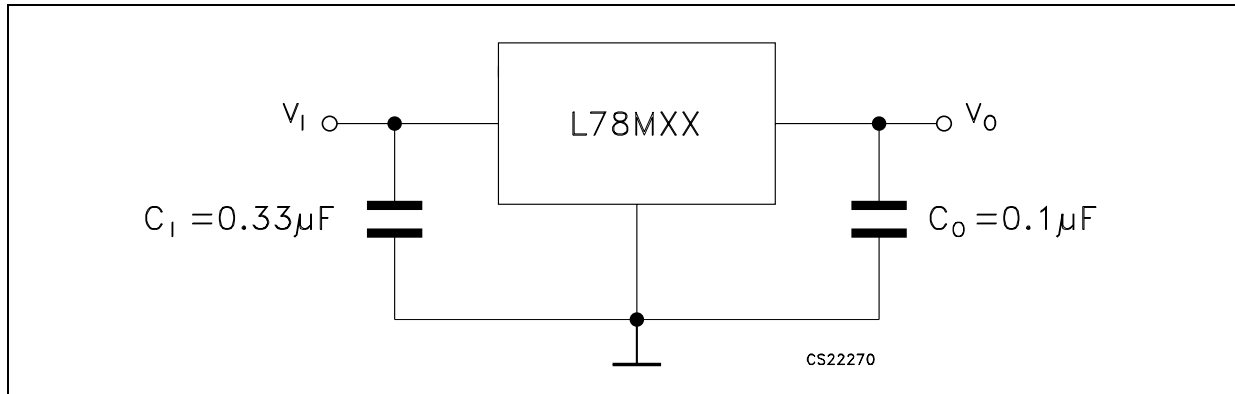

Figure 6. Load regulation

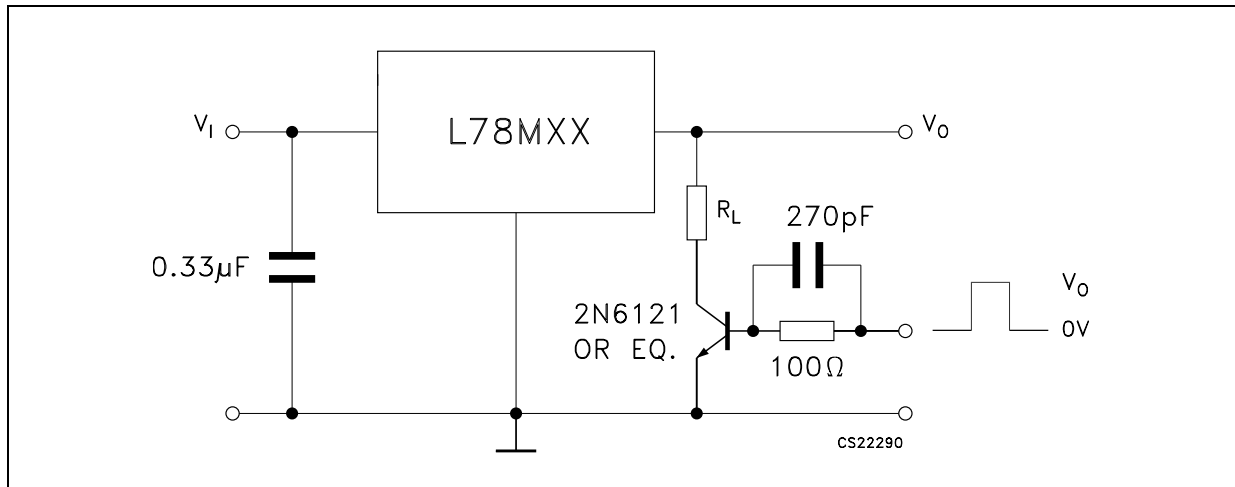
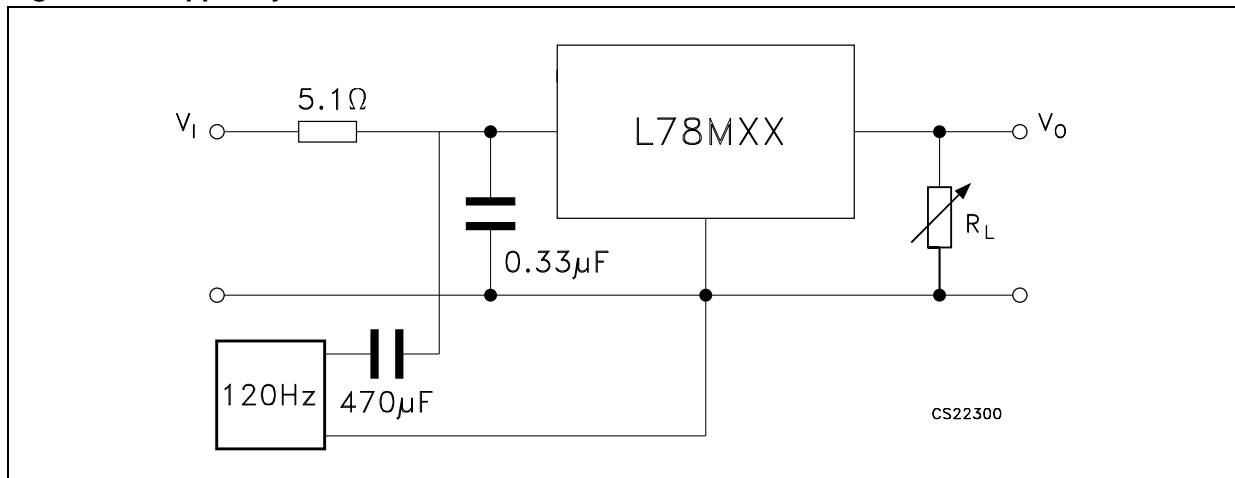

Figure 7. Ripple rejection



[查询"L78MXXC"供应商](#)

5 Electrical characteristics

Table 4. Electrical characteristics of L78M05C (refer to the test circuits, $T_J = 25^\circ\text{C}$, $V_I = 10\text{ V}$, $I_O = 350\text{ mA}$, $C_I = 0.33\ \mu\text{F}$, $C_O = 0.1\ \mu\text{F}$ unless otherwise specified)

Symbol	Parameter	Test conditions	Min.	Typ.	Max.	Unit
V_O	Output voltage		4.8	5	5.2	V
V_O	Output voltage	$I_O = 5\text{ to }350\text{ mA}$, $V_I = 7\text{ to }20\text{ V}$	4.75	5	5.25	V
ΔV_O	Line regulation	$V_I = 7\text{ to }25\text{ V}$, $I_O = 200\text{ mA}$			100	mV
		$V_I = 8\text{ to }25\text{ V}$, $I_O = 200\text{ mA}$			50	
ΔV_O	Load regulation	$I_O = 5\text{ to }500\text{ mA}$, $T_J = 25^\circ\text{C}$			100	mV
		$I_O = 5\text{ to }200\text{ mA}$, $T_J = 25^\circ\text{C}$			50	
I_d	Quiescent current				6	mA
ΔI_d	Quiescent current change	$I_O = 5\text{ to }350\text{ mA}$			0.5	mA
		$I_O = 200\text{ mA}$, $V_I = 8\text{ to }25\text{ V}$			0.8	
$\Delta V_O/\Delta T$	Output voltage drift	$I_O = 5\text{ mA}$, $T_J = 0\text{ to }125^\circ\text{C}$		-0.5		mV/ $^\circ\text{C}$
SVR	Supply voltage rejection	$V_I = 8\text{ to }18\text{ V}$, $f = 120\text{ Hz}$, $I_O = 300\text{ mA}$	62			dB
eN	Output noise voltage	$B = 10\text{ Hz to }100\text{ kHz}$		40		μV
V_d	Dropout voltage			2		V
I_{sc}	Short circuit current	$V_I = 35\text{ V}$		300		mA

Table 5. Electrical characteristics of L78M06C (refer to the test circuits, $T_J = 25^\circ\text{C}$, $V_I = 11\text{ V}$, $I_O = 350\text{ mA}$, $C_I = 0.33\ \mu\text{F}$, $C_O = 0.1\ \mu\text{F}$ unless otherwise specified)

Symbol	Parameter	Test conditions	Min.	Typ.	Max.	Unit
V_O	Output voltage		5.75	6	6.25	V
V_O	Output voltage	$I_O = 5\text{ to }350\text{ mA}$, $V_I = 8\text{ to }21\text{ V}$	5.7	6	6.3	V
ΔV_O	Line regulation	$V_I = 8\text{ to }25\text{ V}$, $I_O = 200\text{ mA}$			100	mV
		$V_I = 9\text{ to }25\text{ V}$, $I_O = 200\text{ mA}$			50	
ΔV_O	Load regulation	$I_O = 5\text{ to }500\text{ mA}$, $T_J = 25^\circ\text{C}$			120	mV
		$I_O = 5\text{ to }200\text{ mA}$, $T_J = 25^\circ\text{C}$			60	
I_d	Quiescent current				6	mA
ΔI_d	Quiescent current change	$I_O = 5\text{ to }350\text{ mA}$			0.5	mA
		$I_O = 200\text{ mA}$, $V_I = 9\text{ to }25\text{ V}$			0.8	
$\Delta V_O/\Delta T$	Output voltage drift	$I_O = 5\text{ mA}$, $T_J = 0\text{ to }125^\circ\text{C}$		-0.5		mV/ $^\circ\text{C}$
SVR	Supply voltage rejection	$V_I = 9\text{ to }19\text{ V}$, $f = 120\text{ Hz}$, $I_O = 300\text{ mA}$	59			dB
eN	Output noise voltage	$B = 10\text{ Hz to }100\text{ kHz}$		45		μV
V_d	Dropout voltage			2		V
I_{sc}	Short circuit current	$V_I = 35\text{ V}$		270		mA

[查询"L78MXXC"供应商](#)**Table 6. Electrical characteristics of L78M08C** (refer to the test circuits, $T_J = 25\text{ }^\circ\text{C}$, $V_I = 14\text{ V}$, $I_O = 350\text{ mA}$, $C_I = 0.33\text{ }\mu\text{F}$, $C_O = 0.1\text{ }\mu\text{F}$ unless otherwise specified)

Symbol	Parameter	Test conditions	Min.	Typ.	Max.	Unit
V_O	Output voltage		7.7	8	8.3	V
V_O	Output voltage	$I_O = 5\text{ to }350\text{ mA}$, $V_I = 10.5\text{ to }23\text{ V}$	7.6	8	8.4	V
ΔV_O	Line regulation	$V_I = 10.5\text{ to }25\text{ V}$, $I_O = 200\text{ mA}$			100	mV
		$V_I = 11\text{ to }25\text{ V}$, $I_O = 200\text{ mA}$			50	
ΔV_O	Load regulation	$I_O = 5\text{ to }500\text{ mA}$, $T_J = 25\text{ }^\circ\text{C}$			160	mV
		$I_O = 5\text{ to }200\text{ mA}$, $T_J = 25\text{ }^\circ\text{C}$			80	
I_d	Quiescent current				6	mA
ΔI_d	Quiescent current change	$I_O = 5\text{ to }350\text{ mA}$			0.5	mA
		$I_O = 200\text{ mA}$, $V_I = 10.5\text{ to }25\text{ V}$			0.8	
$\Delta V_O/\Delta T$	Output voltage drift	$I_O = 5\text{ mA}$, $T_J = 0\text{ to }125\text{ }^\circ\text{C}$		-0.5		mV/°C
SVR	Supply voltage rejection	$V_I = 11.5\text{ to }21.5\text{ V}$, $f = 120\text{ Hz}$, $I_O = 300\text{ mA}$	56			dB
eN	Output noise voltage	$B = 10\text{ Hz to }100\text{ kHz}$		52		μV
V_d	Dropout voltage			2		V
I_{sc}	Short circuit current	$V_I = 35\text{ V}$		250		mA

Table 7. Electrical characteristics of L78M09C (refer to the test circuits, $T_J = 25\text{ }^\circ\text{C}$, $V_I = 15\text{ V}$, $I_O = 350\text{ mA}$, $C_I = 0.33\text{ }\mu\text{F}$, $C_O = 0.1\text{ }\mu\text{F}$ unless otherwise specified)

Symbol	Parameter	Test conditions	Min.	Typ.	Max.	Unit
V_O	Output voltage		8.65	9	9.35	V
V_O	Output voltage	$I_O = 5\text{ to }350\text{ mA}$, $V_I = 11.5\text{ to }24\text{ V}$	8.55	9	9.45	V
ΔV_O	Line regulation	$V_I = 11.5\text{ to }25\text{ V}$, $I_O = 200\text{ mA}$			100	mV
		$V_I = 12\text{ to }25\text{ V}$, $I_O = 200\text{ mA}$			50	
ΔV_O	Load regulation	$I_O = 5\text{ to }500\text{ mA}$, $T_J = 25\text{ }^\circ\text{C}$			180	mV
		$I_O = 5\text{ to }200\text{ mA}$, $T_J = 25\text{ }^\circ\text{C}$			90	
I_d	Quiescent current				6	mA
ΔI_d	Quiescent current change	$I_O = 5\text{ to }350\text{ mA}$			0.5	mA
		$I_O = 200\text{ mA}$, $V_I = 11.5\text{ to }25\text{ V}$			0.8	
$\Delta V_O/\Delta T$	Output voltage drift	$I_O = 5\text{ mA}$, $T_J = 0\text{ to }125\text{ }^\circ\text{C}$		-0.5		mV/°C
SVR	Supply voltage rejection	$V_I = 12.5\text{ to }23\text{ V}$, $f = 120\text{ Hz}$, $I_O = 300\text{ mA}$	56			dB
eN	Output noise voltage	$B = 10\text{ Hz to }100\text{ kHz}$		58		μV
V_d	Dropout voltage			2		V
I_{sc}	Short circuit current	$V_I = 35\text{ V}$		250		mA

[查询"L78MXXC"供应商](#)**Table 8. Electrical characteristics of L78M12C** (refer to the test circuits, $T_J = 25^\circ\text{C}$, $V_I = 19\text{ V}$, $I_O = 350\text{ mA}$, $C_I = 0.33\ \mu\text{F}$, $C_O = 0.1\ \mu\text{F}$ unless otherwise specified)

Symbol	Parameter	Test conditions	Min.	Typ.	Max.	Unit
V_O	Output voltage		11.5	12	12.5	V
V_O	Output voltage	$I_O = 5\text{ to }350\text{ mA}$, $V_I = 14.5\text{ to }27\text{ V}$	11.4	12	12.6	V
ΔV_O	Line regulation	$V_I = 14.5\text{ to }30\text{ V}$, $I_O = 200\text{ mA}$			100	mV
		$V_I = 16\text{ to }30\text{ V}$, $I_O = 200\text{ mA}$			50	
ΔV_O	Load regulation	$I_O = 5\text{ to }500\text{ mA}$, $T_J = 25^\circ\text{C}$			240	mV
		$I_O = 5\text{ to }200\text{ mA}$, $T_J = 25^\circ\text{C}$			120	
I_d	Quiescent current				6	mA
ΔI_d	Quiescent current change	$I_O = 5\text{ to }350\text{ mA}$			0.5	mA
		$I_O = 200\text{ mA}$, $V_I = 14.5\text{ to }30\text{ V}$			0.8	
$\Delta V_O/\Delta T$	Output voltage drift	$I_O = 5\text{ mA}$, $T_J = 0\text{ to }125^\circ\text{C}$		-1		mV/ $^\circ\text{C}$
SVR	Supply voltage rejection	$V_I = 15\text{ to }25\text{ V}$, $f = 120\text{ Hz}$, $I_O = 300\text{ mA}$	55			dB
eN	Output noise voltage	$B = 10\text{ Hz to }100\text{ kHz}$		75		μV
V_d	Dropout voltage			2		V
I_{sc}	Short circuit current	$V_I = 35\text{ V}$		240		mA

Table 9. Electrical characteristics of L78M15C (refer to the test circuits, $T_J = 25^\circ\text{C}$, $V_I = 23\text{ V}$, $I_O = 350\text{ mA}$, $C_I = 0.33\ \mu\text{F}$, $C_O = 0.1\ \mu\text{F}$ unless otherwise specified)

Symbol	Parameter	Test conditions	Min.	Typ.	Max.	Unit
V_O	Output voltage		14.4	15	15.6	V
V_O	Output voltage	$I_O = 5\text{ to }350\text{ mA}$, $V_I = 17.5\text{ to }30\text{ V}$	14.25	15	15.75	V
ΔV_O	Line regulation	$V_I = 17.5\text{ to }30\text{ V}$, $I_O = 200\text{ mA}$			100	mV
		$V_I = 20\text{ to }30\text{ V}$, $I_O = 200\text{ mA}$			50	
ΔV_O	Load regulation	$I_O = 5\text{ to }500\text{ mA}$, $T_J = 25^\circ\text{C}$			300	mV
		$I_O = 5\text{ to }200\text{ mA}$, $T_J = 25^\circ\text{C}$			150	
I_d	Quiescent current				6	mA
ΔI_d	Quiescent current change	$I_O = 5\text{ to }350\text{ mA}$			0.5	mA
		$I_O = 200\text{ mA}$, $V_I = 17.5\text{ to }30\text{ V}$			0.8	
$\Delta V_O/\Delta T$	Output voltage drift	$I_O = 5\text{ mA}$, $T_J = 0\text{ to }125^\circ\text{C}$		-1		mV/ $^\circ\text{C}$
SVR	Supply voltage rejection	$V_I = 18.5\text{ to }28.5\text{ V}$, $f = 120\text{ Hz}$, $I_O = 300\text{ mA}$	54			dB
eN	Output noise voltage	$B = 10\text{ Hz to }100\text{ kHz}$		90		μV
V_d	Dropout voltage			2		V
I_{sc}	Short circuit current	$V_I = 35\text{ V}$		240		mA

[查询"L78MXXC"供应商](#)**Table 10. Electrical characteristics of L78M18C** (refer to the test circuits, $T_J = 25^\circ\text{C}$, $V_I = 26\text{ V}$, $I_O = 350\text{ mA}$, $C_I = 0.33\ \mu\text{F}$, $C_O = 0.1\ \mu\text{F}$ unless otherwise specified)

Symbol	Parameter	Test conditions	Min.	Typ.	Max.	Unit
V_O	Output voltage		17.3	18	18.7	V
V_O	Output voltage	$I_O = 5\text{ to }350\text{ mA}$, $V_I = 20.5\text{ to }33\text{ V}$	17.1	18	18.9	V
ΔV_O	Line regulation	$V_I = 21\text{ to }33\text{ V}$, $I_O = 200\text{ mA}$			100	mV
		$V_I = 24\text{ to }33\text{ V}$, $I_O = 200\text{ mA}$			50	
ΔV_O	Load regulation	$I_O = 5\text{ to }500\text{ mA}$, $T_J = 25^\circ\text{C}$			360	mV
		$I_O = 5\text{ to }200\text{ mA}$, $T_J = 25^\circ\text{C}$			180	
I_d	Quiescent current				6	mA
ΔI_d	Quiescent current change	$I_O = 5\text{ to }350\text{ mA}$			0.5	mA
		$I_O = 200\text{ mA}$, $V_I = 21\text{ to }33\text{ V}$			0.8	
$\Delta V_O/\Delta T$	Output voltage drift	$I_O = 5\text{ mA}$, $T_J = 0\text{ to }125^\circ\text{C}$		-1.1		mV/ $^\circ\text{C}$
SVR	Supply voltage rejection	$V_I = 22\text{ to }32\text{ V}$, $f = 120\text{ Hz}$, $I_O = 300\text{ mA}$	53			dB
eN	Output noise voltage	$B = 10\text{ Hz to }100\text{ kHz}$		100		μV
V_d	Dropout voltage			2		V
I_{sc}	Short circuit current	$V_I = 35\text{ V}$		240		mA

Table 11. Electrical characteristics of L78M24C (refer to the test circuits, $T_J = 25^\circ\text{C}$, $V_I = 23\text{ V}$, $I_O = 350\text{ mA}$, $C_I = 0.33\ \mu\text{F}$, $C_O = 0.1\ \mu\text{F}$ unless otherwise specified)

Symbol	Parameter	Test conditions	Min.	Typ.	Max.	Unit
V_O	Output voltage		23	24	25	V
V_O	Output voltage	$I_O = 5\text{ to }350\text{ mA}$, $V_I = 27\text{ to }38\text{ V}$	22.8	24	25.2	V
ΔV_O	Line regulation	$V_I = 27\text{ to }38\text{ V}$, $I_O = 200\text{ mA}$			100	mV
		$V_I = 28\text{ to }38\text{ V}$, $I_O = 200\text{ mA}$			50	
ΔV_O	Load regulation	$I_O = 5\text{ to }500\text{ mA}$, $T_J = 25^\circ\text{C}$			480	mV
		$I_O = 5\text{ to }200\text{ mA}$, $T_J = 25^\circ\text{C}$			240	
I_d	Quiescent current				6	mA
ΔI_d	Quiescent current change	$I_O = 5\text{ to }350\text{ mA}$			0.5	mA
		$I_O = 200\text{ mA}$, $V_I = 27\text{ to }38\text{ V}$			0.8	
$\Delta V_O/\Delta T$	Output voltage drift	$I_O = 5\text{ mA}$, $T_J = 0\text{ to }125^\circ\text{C}$		-1.2		mV/ $^\circ\text{C}$
SVR	Supply voltage rejection	$V_I = 28\text{ to }38\text{ V}$, $f = 120\text{ Hz}$, $I_O = 300\text{ mA}$	50			dB
eN	Output noise voltage	$B = 10\text{ Hz to }100\text{ kHz}$		170		μV
V_d	Dropout voltage			2		V
I_{sc}	Short circuit current	$V_I = 35\text{ V}$		240		mA

[查询"L78MXXC"供应商](#)

6 Typical performance

Figure 8. Dropout voltage vs junction temp.

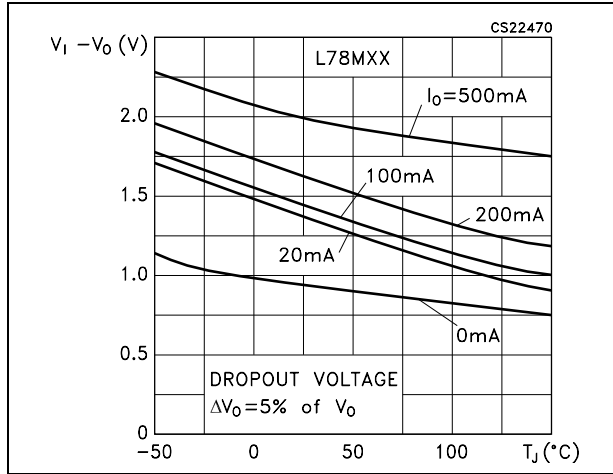

Figure 9. Dropout characteristics

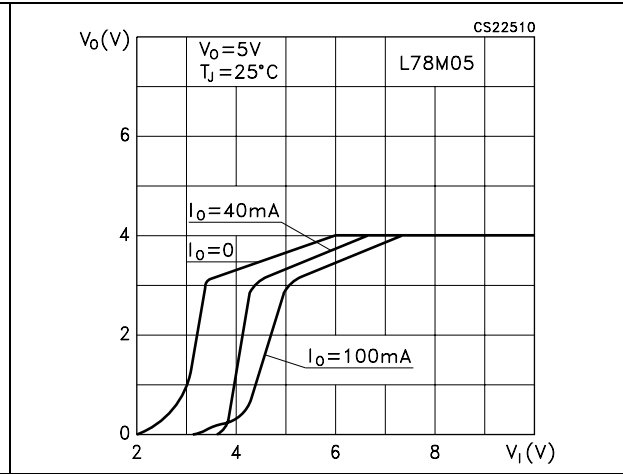

Figure 10. Peak output current vs input-output differential voltage

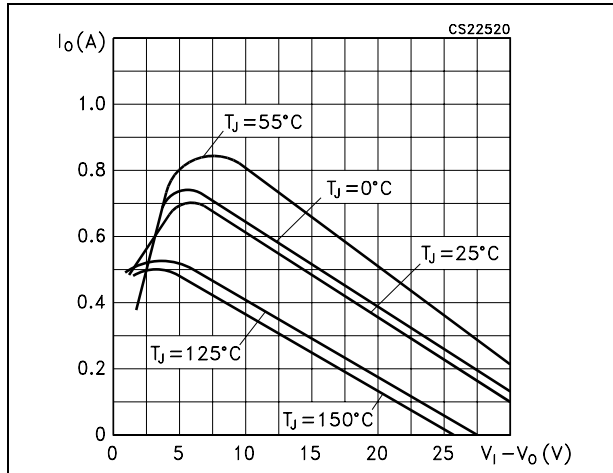

Figure 11. Output voltage vs junction temperature

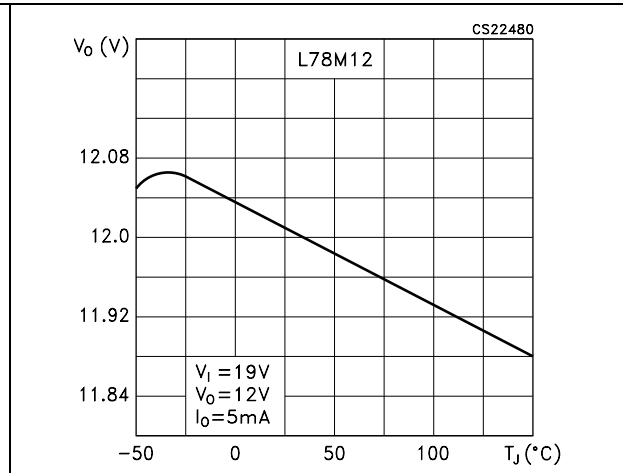

Figure 12. Supply voltage rejection vs freq.

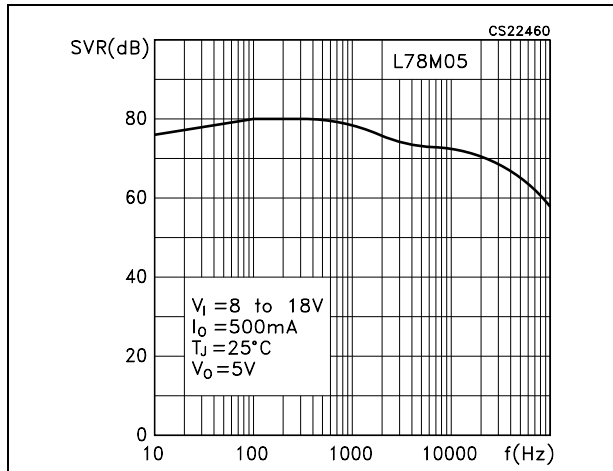
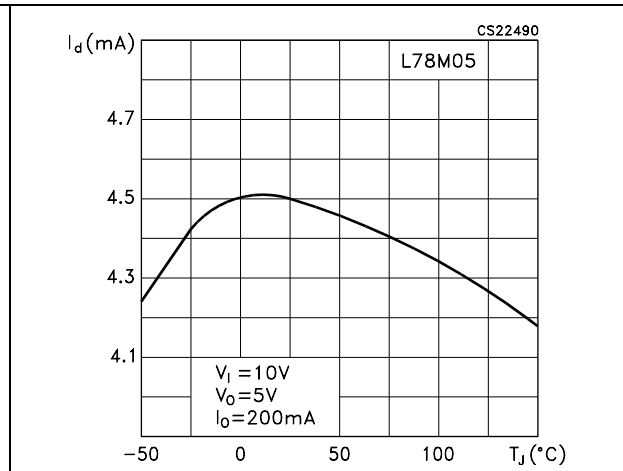

Figure 13. Quiescent current vs junction temp.



[查询"L78MXXC"供应商](#)

Figure 14. Load transient response

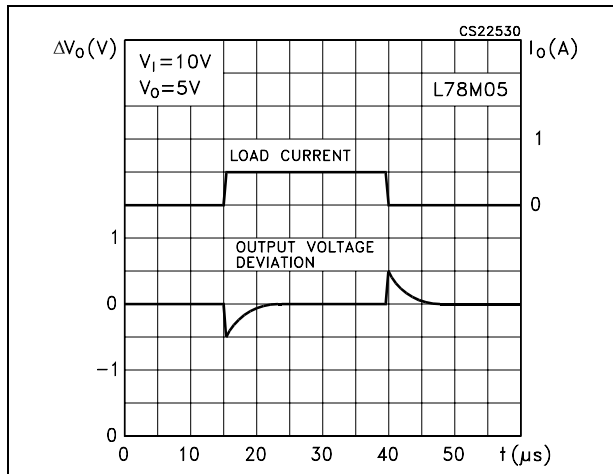

Figure 15. Line transient response

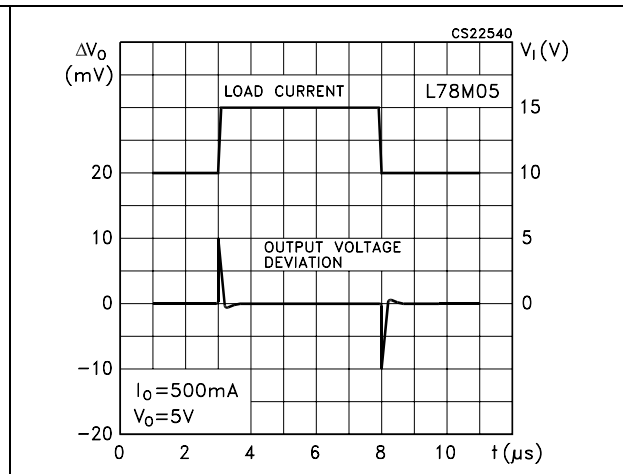

Figure 16. Quiescent current vs input voltage

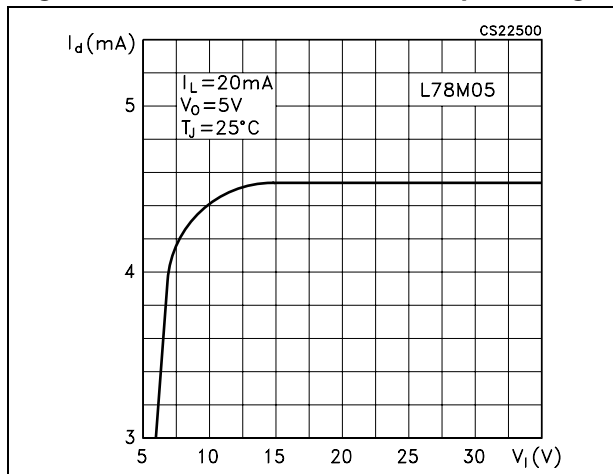
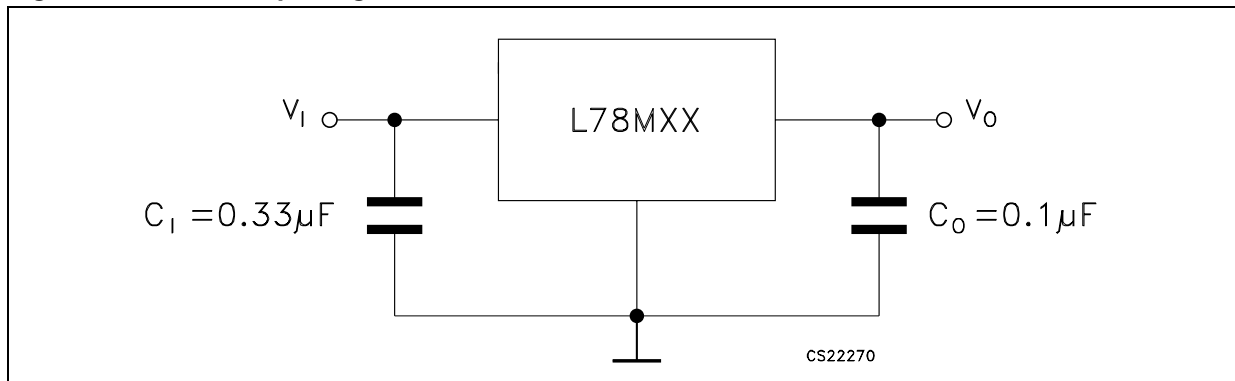

Figure 17. Fixed output regulator



1. To specify an output voltage, substitute voltage value for "XX".
2. Although no output capacitor is need for stability, it does improve transient response.
3. Required if regulator is locate an appreciable distance from power supply filter.

[查询"L78MXXC"供应商](#)

Figure 18. Constant current regulator

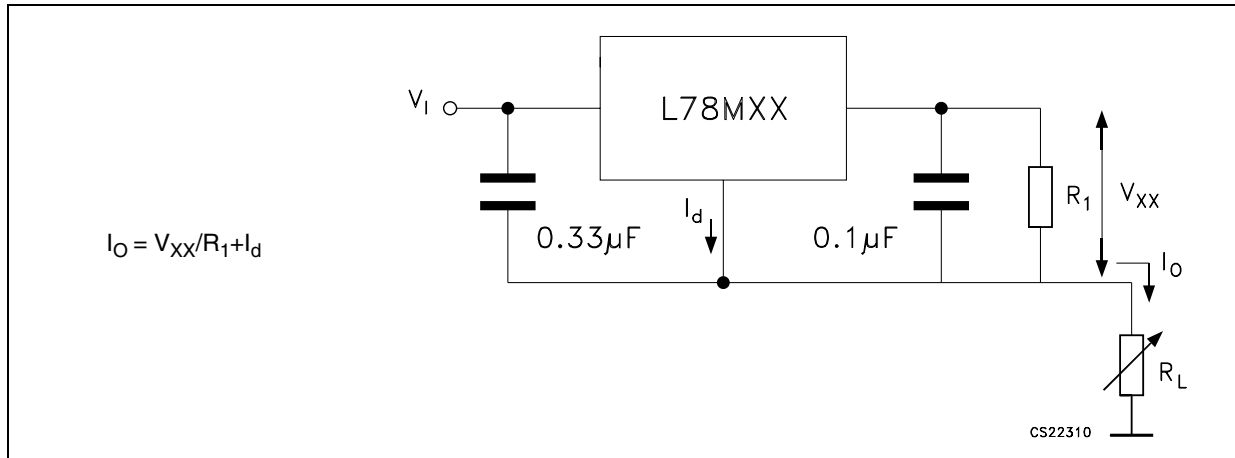

Figure 19. Circuit for increasing output voltage

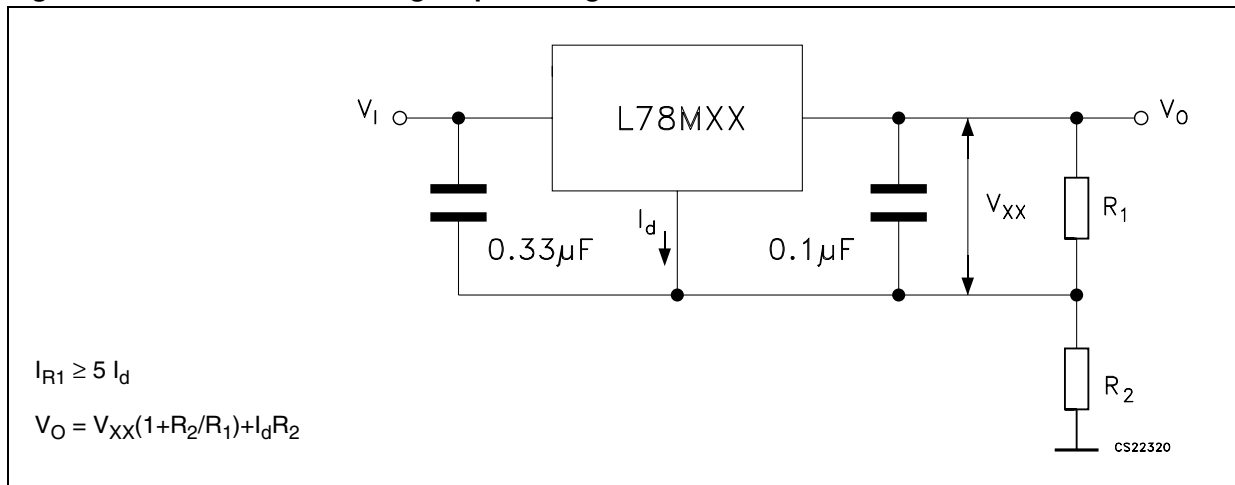
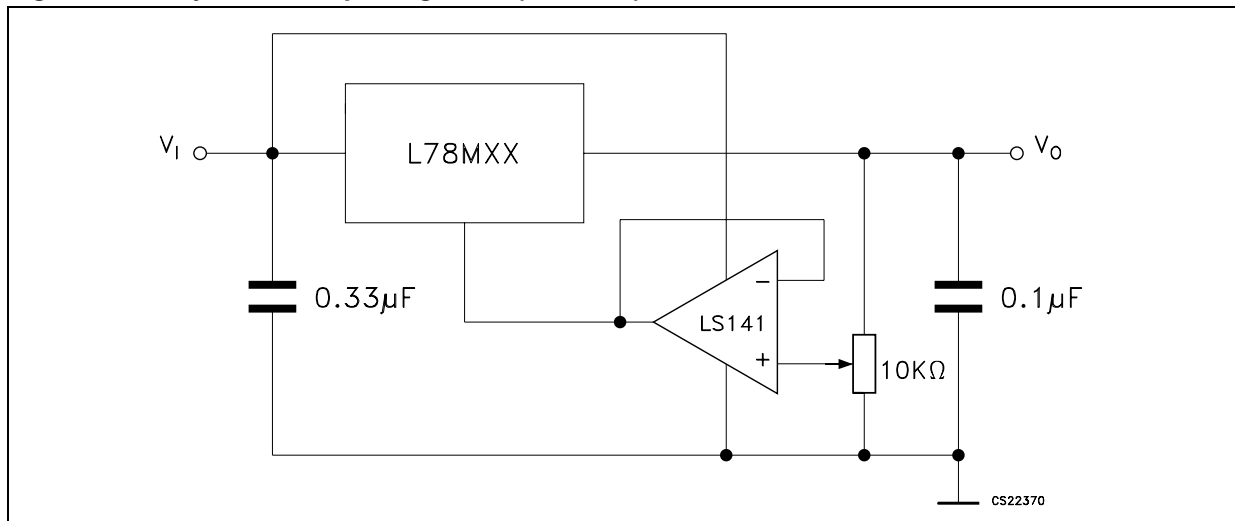

Figure 20. Adjustable output regulator (7 to 30 V)



[查询"L78MXXC"供应商](#)

Figure 21. 0.5 to 10 V regulator

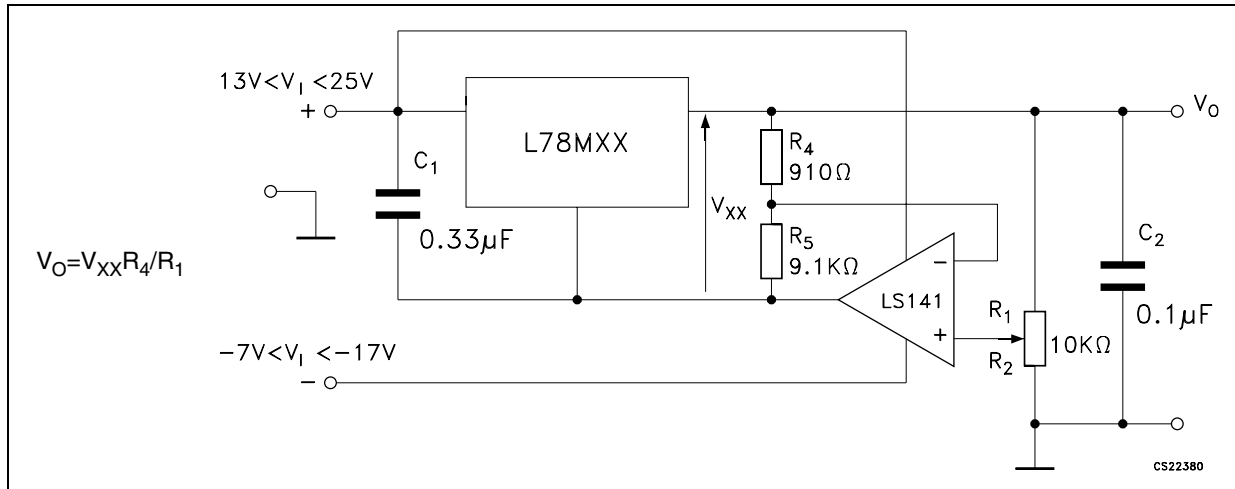

Figure 22. High current voltage regulator

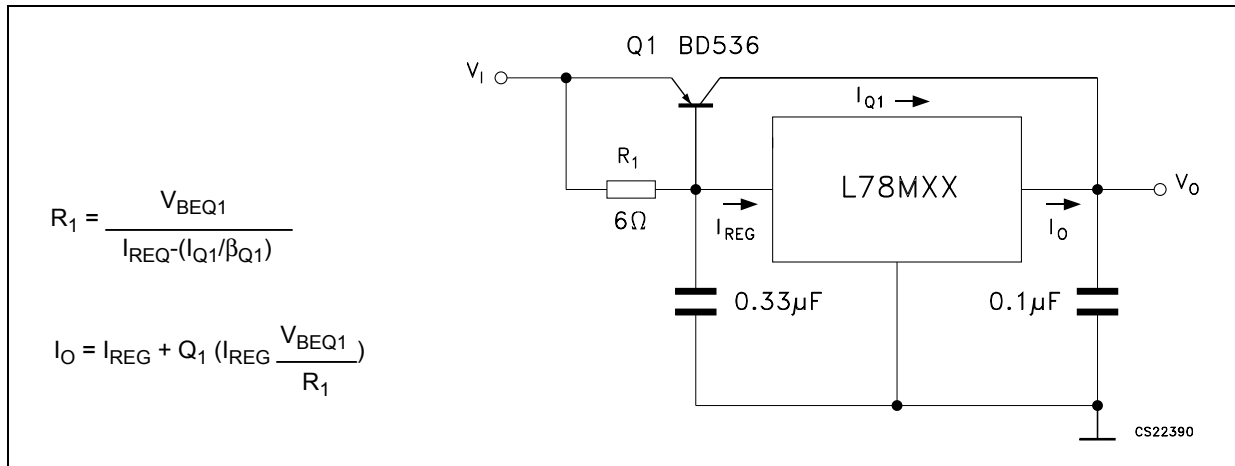
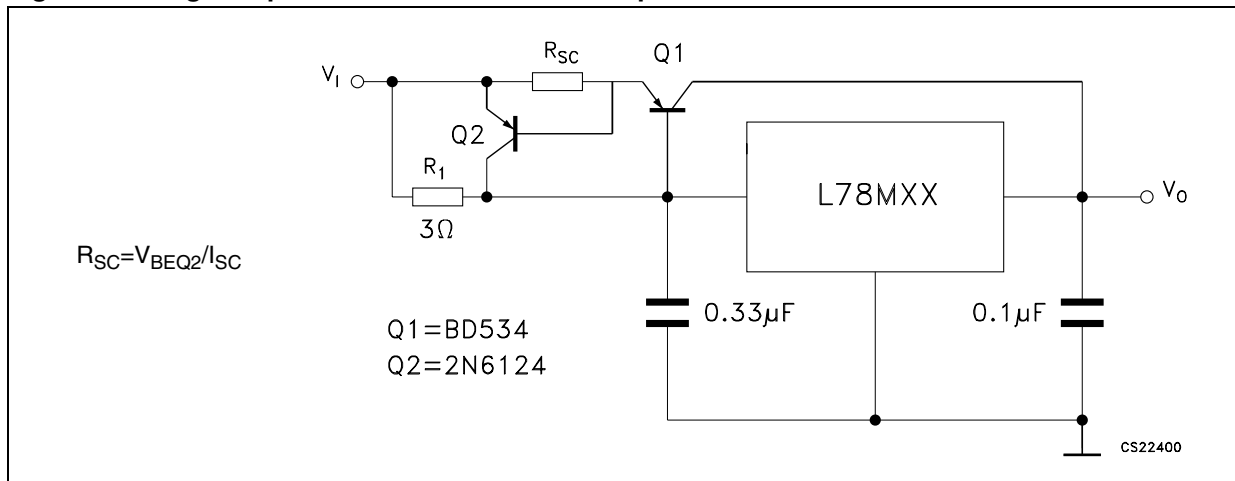

Figure 23. High output current with short circuit protection



[查询"L78MXXC"供应商](#)

Figure 24. Tracking voltage regulator

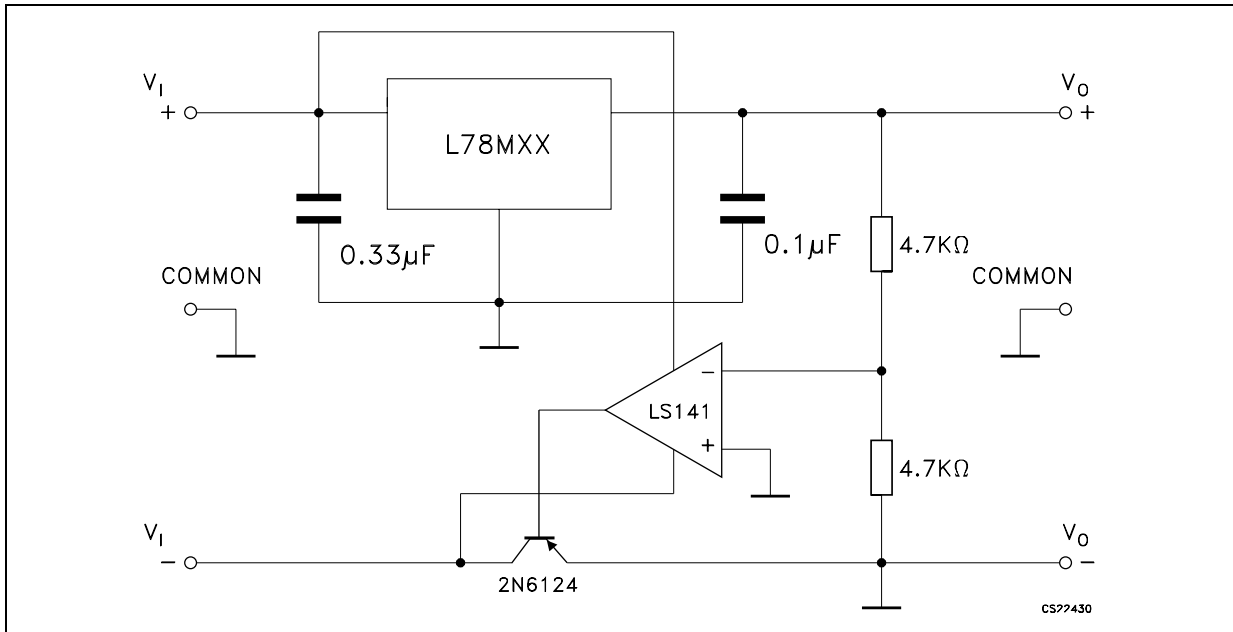

Figure 25. High input voltage circuit

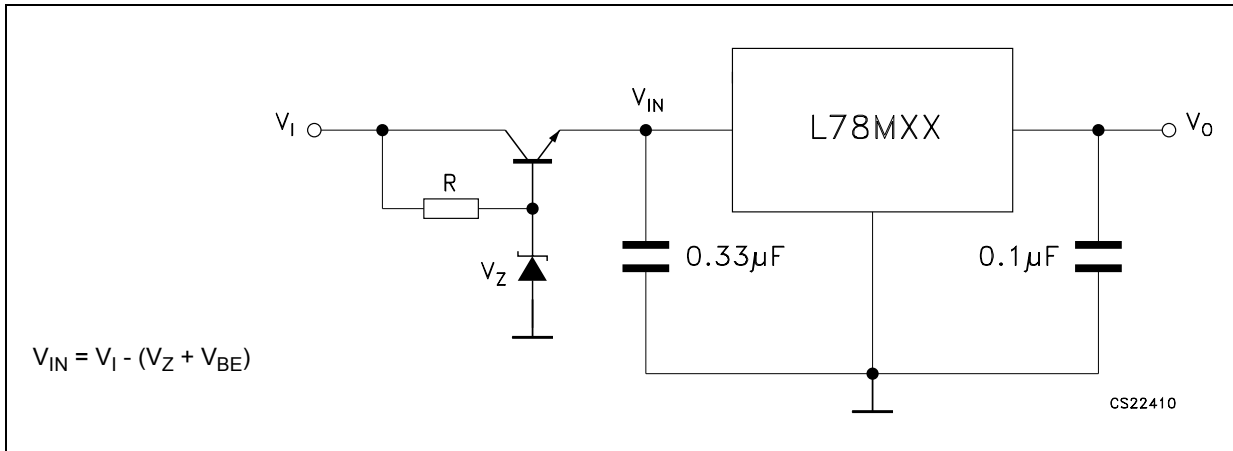
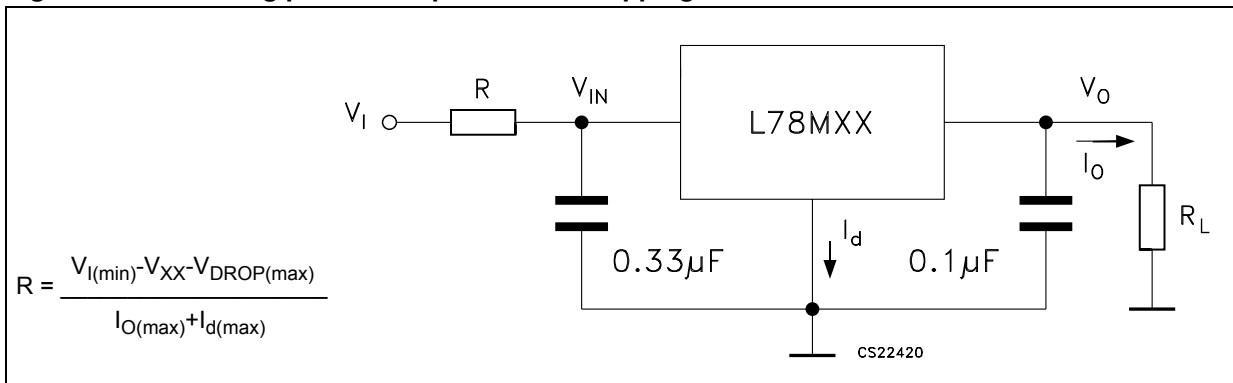
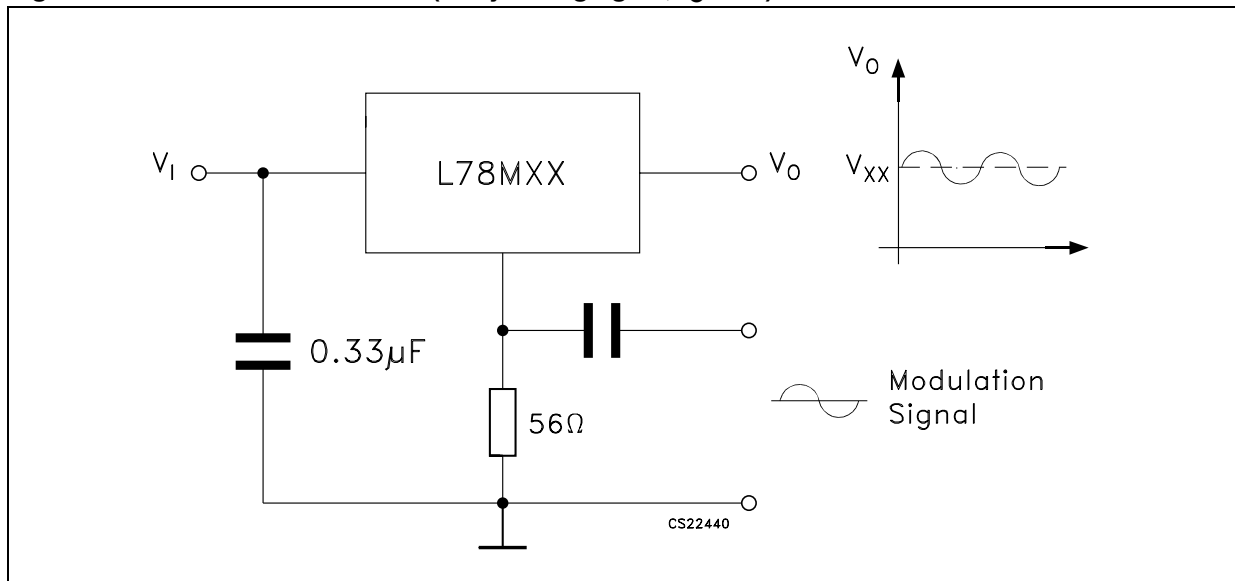

Figure 26. Reducing power dissipation with dropping resistor



[查询"L78MXXC"供应商](#)

Figure 27. Power AM modulator (unity voltage gain, $I_O \leq 0.5$)



Note: The circuit performs well up to 100 kHz.

Figure 28. Adjustable output voltage with temperature compensation

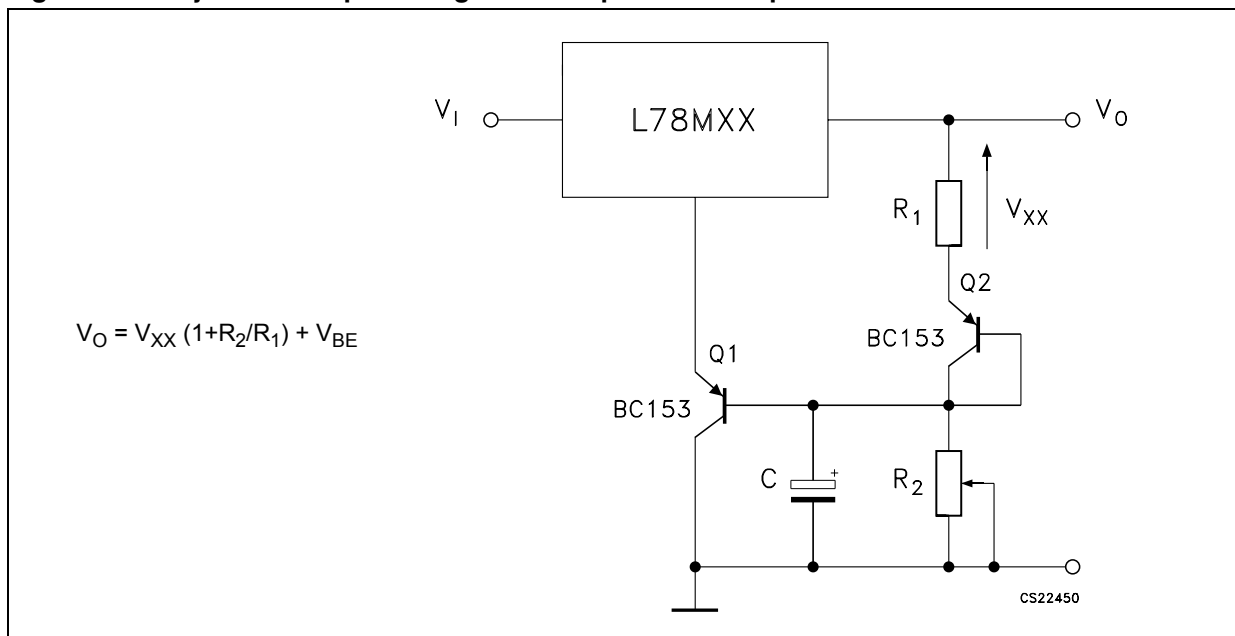

Note: Q_2 is connected as a diode in order to compensate the variation of the Q_1 V_{BE} with the temperature. C allows a slow rise time of the V_O .

[查询"L78MXXC"供应商](#)

7 Package mechanical data

In order to meet environmental requirements, ST offers these devices in ECOPACK[®] packages. These packages have a lead-free second level interconnect. The category of second Level Interconnect is marked on the package and on the inner box label, in compliance with JEDEC Standard JESD97. The maximum ratings related to soldering conditions are also marked on the inner box label. ECOPACK is an ST trademark. ECOPACK specifications are available at: www.st.com.

[查询"L78MXXC"供应商](#)

TO-220 mechanical data

Dim.	mm.			inch.		
	Min.	Typ.	Max.	Min.	Typ.	Max.
A	4.40		4.60	0.173		0.181
C	1.23		1.32	0.048		0.051
D	2.40		2.72	0.094		0.107
D1		1.27			0.050	
E	0.49		0.70	0.019		0.027
F	0.61		0.88	0.024		0.034
F1	1.14		1.70	0.044		0.067
F2	1.14		1.70	0.044		0.067
G	4.95		5.15	0.194		0.203
G1	2.4		2.7	0.094		0.106
H2	10.0		10.40	0.393		0.409
L2		16.4			0.645	
L4	13.0		14.0	0.511		0.551
L5	2.65		2.95	0.104		0.116
L6	15.25		15.75	0.600		0.620
L7	6.2		6.6	0.244		0.260
L9	3.5		3.93	0.137		0.154
DIA.	3.75		3.85	0.147		0.151

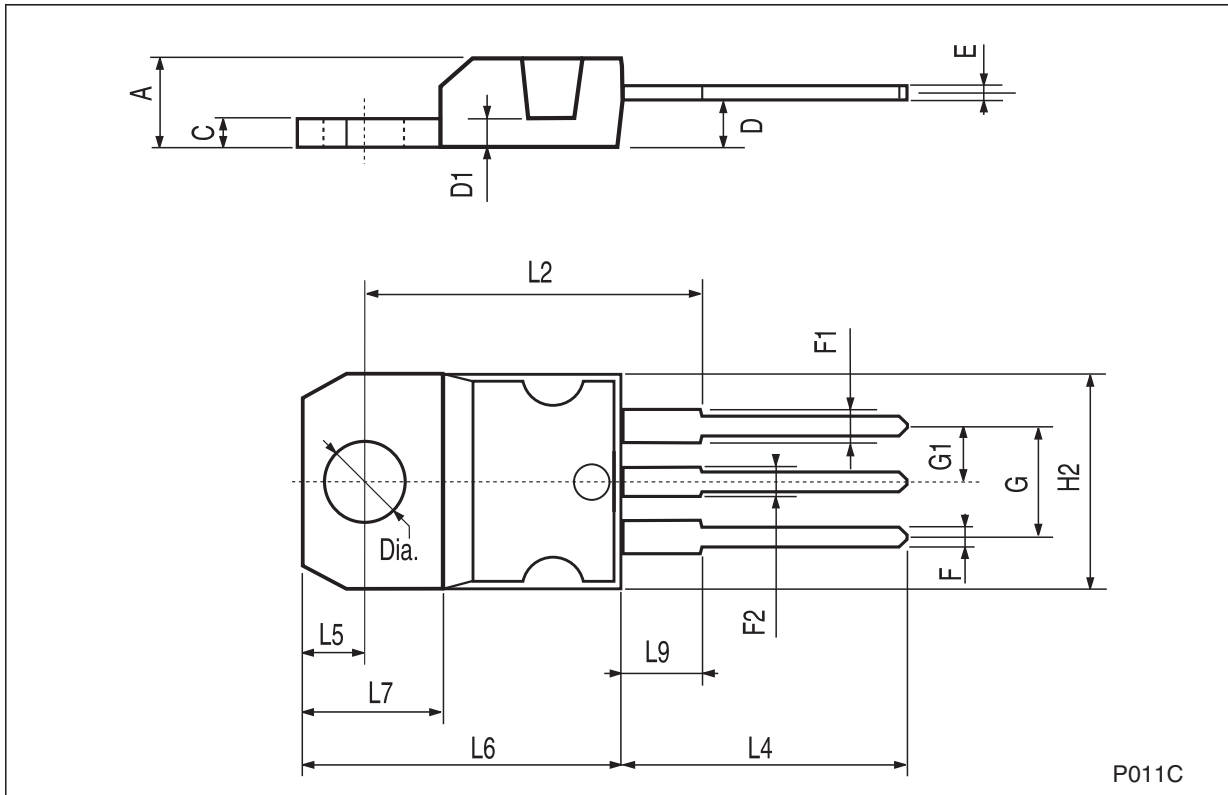

P011C

[查询"L78MXXC"供应商](#)

TO-220FP mechanical data

Dim.	mm.			inch.		
	Min.	Typ	Max.	Min.	Typ.	Max.
A	4.40		4.60	0.173		0.181
B	2.5		2.7	0.098		0.106
D	2.5		2.75	0.098		0.108
E	0.45		0.70	0.017		0.027
F	0.75		1	0.030		0.039
F1	1.15		1.50	0.045		0.059
F2	1.15		1.50	0.045		0.059
G	4.95		5.2	0.194		0.204
G1	2.4		2.7	0.094		0.106
H	10.0		10.40	0.393		0.409
L2		16			0.630	
L3	28.6		30.6	1.126		1.204
L4	9.8		10.6	0.385		0.417
L5	2.9		3.6	0.114		0.142
L6	15.9		16.4	0.626		0.645
L7	9		9.3	0.354		0.366
DIA.	3		3.2	0.118		0.126

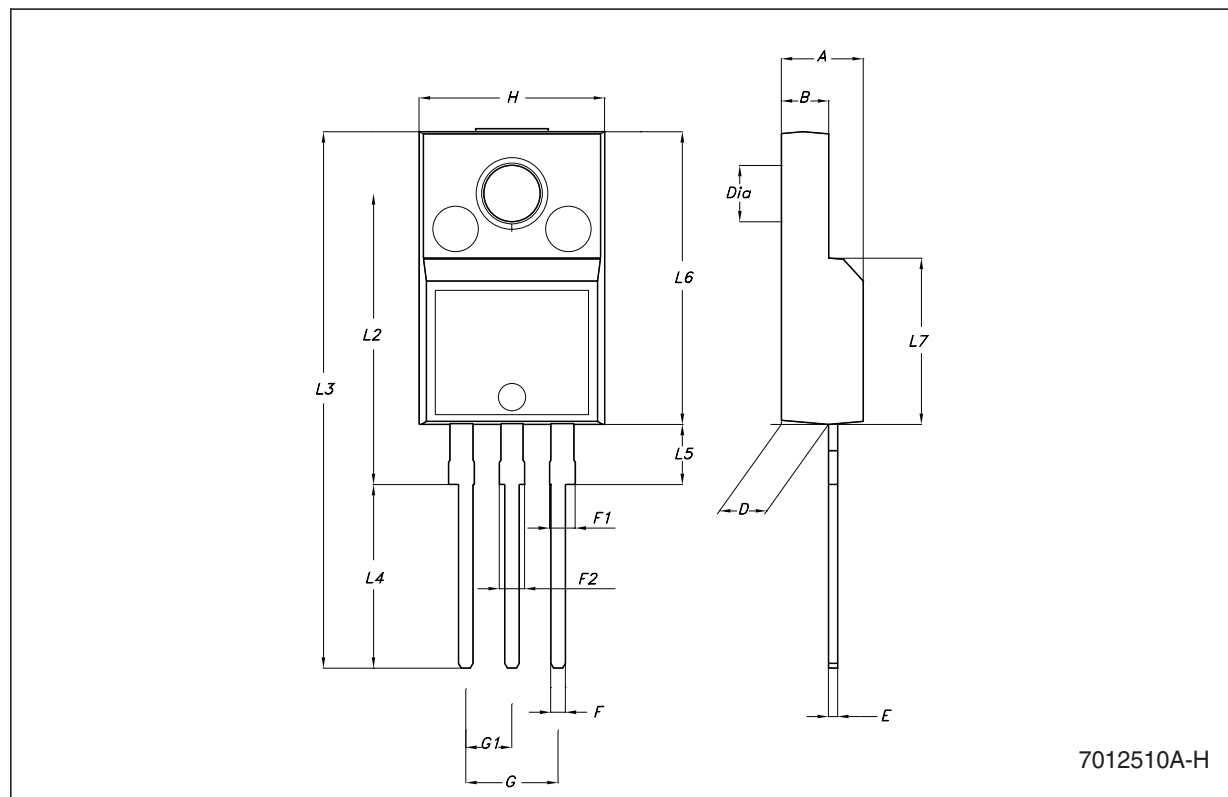

[查询"L78MXXC"供应商](#)

Figure 29. Drawing dimension DPAK (type STD-ST)

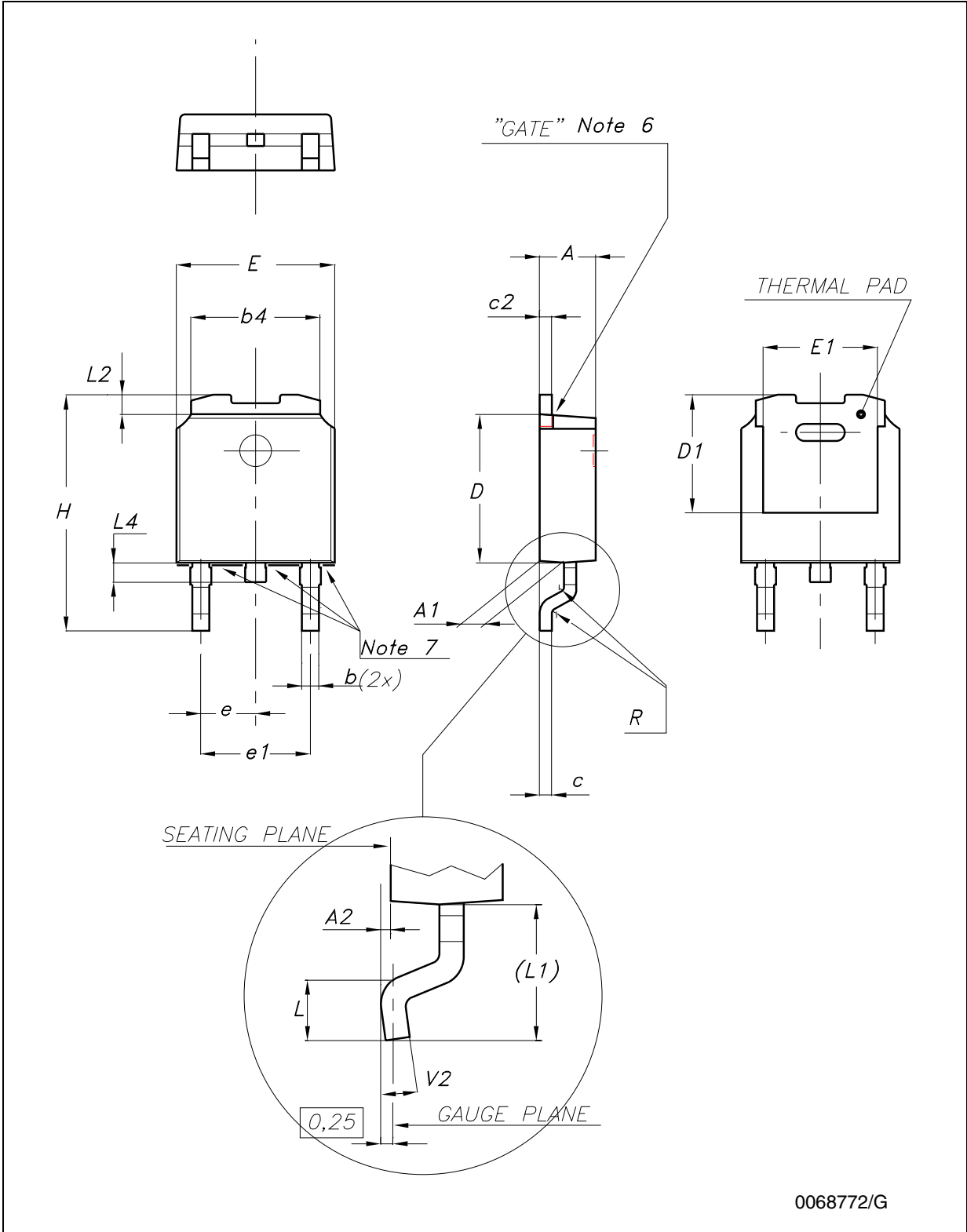

[查询"L78MXXC"供应商](#)

Figure 30. Drawing dimension DPAK (type FUJITSU-subcon.)

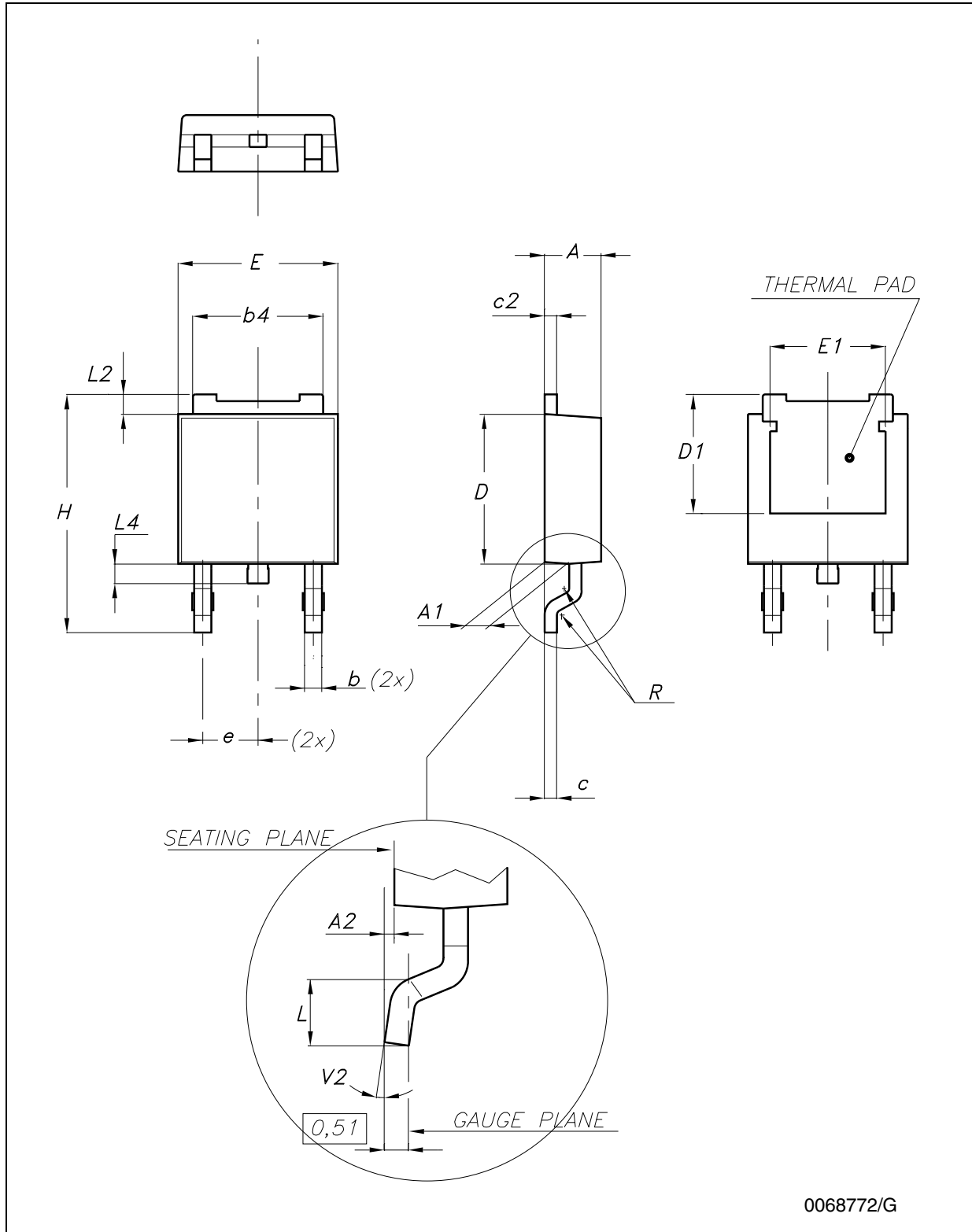

[查询"L78MXXC"供应商](#)

Table 12. DPAK mechanical data

Dim.	Type STD-ST			Type FUJITSU-SUBCON.			Type IDS-SUBCON		
	mm.			mm.			mm.		
	Min.	Typ.	Max.	Min.	Typ.	Max.	Min.	Typ.	Max.
A	2.20		2.40	2.25	2.30	2.35	2.19		2.38
A1	0.90		1.10	0.96		1.06	0.89		1.14
A2	0.03		0.23	0		0.10	0.03		0.23
b	0.64		0.90	0.76		0.86	0.64		0.88
b4	5.20		5.40	5.28		5.38	5.21		5.46
c	0.45		0.60	0.46		0.56	0.46		0.58
c2	0.48		0.60	0.46		0.56	0.46		0.58
D	6.00		6.20	6.05		6.15	5.97		6.22
D1		5.10		5.27		5.47		5.20	
E	6.40		6.60	6.55	6.60	6.65	6.35		6.73
E1		4.70			4.77			4.70	
e		2.28		2.23	2.28	2.33		2.28	
e1	4.40		4.60				4.51		4.61
H	9.35		10.10	9.90		10.30	9.40		10.42
L	1.00			1.40		1.60	0.90		
L1		2.80					2.50		2.65
L2		0.80		1.03		1.13	0.89		1.27
L4	0.60		1.00	0.70		0.90	0.64		1.02
R		0.20			0.40			0.20	
V2	0°		8°	0°		8°	0°		8°

Note: The DPAK package coming from the two subcontractors (Fujitsu and IDS) are fully compatible with the ST's package suggested footprint.

[查询"L78MXXC"供应商](#)

Figure 32. DPAK footprint recommended data

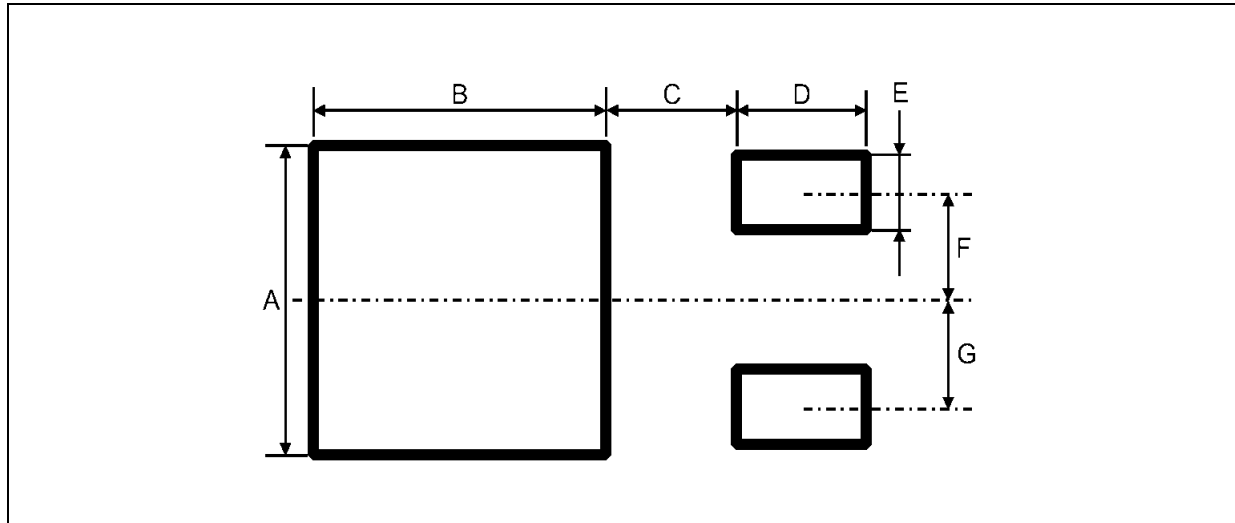

Table 13. Footprint data

Dim.	Values	
	mm.	inch.
A	6.70	0.264
B	6.70	0.64
C	1.8	0.070
D	3.0	0.118
E	1.60	0.063
F	2.30	0.091
G	2.30	0.091

[查询"L78MXXC"供应商](#)

IPAK mechanical data

Dim.	mm.			inch.		
	Min.	Typ.	Max.	Min.	Typ.	Max.
A	2.2		2.4	0.086		0.094
A1	0.9		1.1	0.035		0.043
B	0.64		0.9	0.025		0.035
B2	5.2		5.4	0.204		0.212
B3			0.95			0.037
B5		0.3			0.012	
B6			0.95			0.037
C	0.45		0.6	0.017		0.023
C2	0.48		0.6	0.019		0.023
D	6		6.2	0.236		0.244
E	6.4		6.6	0.252		0.260
G	4.4		4.6	0.173		0.181
H	15.9		16.3	0.626		0.641
L	9		9.4	0.354		0.370
L1	0.8		1.2	0.031		0.047
L2		0.8	1		0.031	0.039

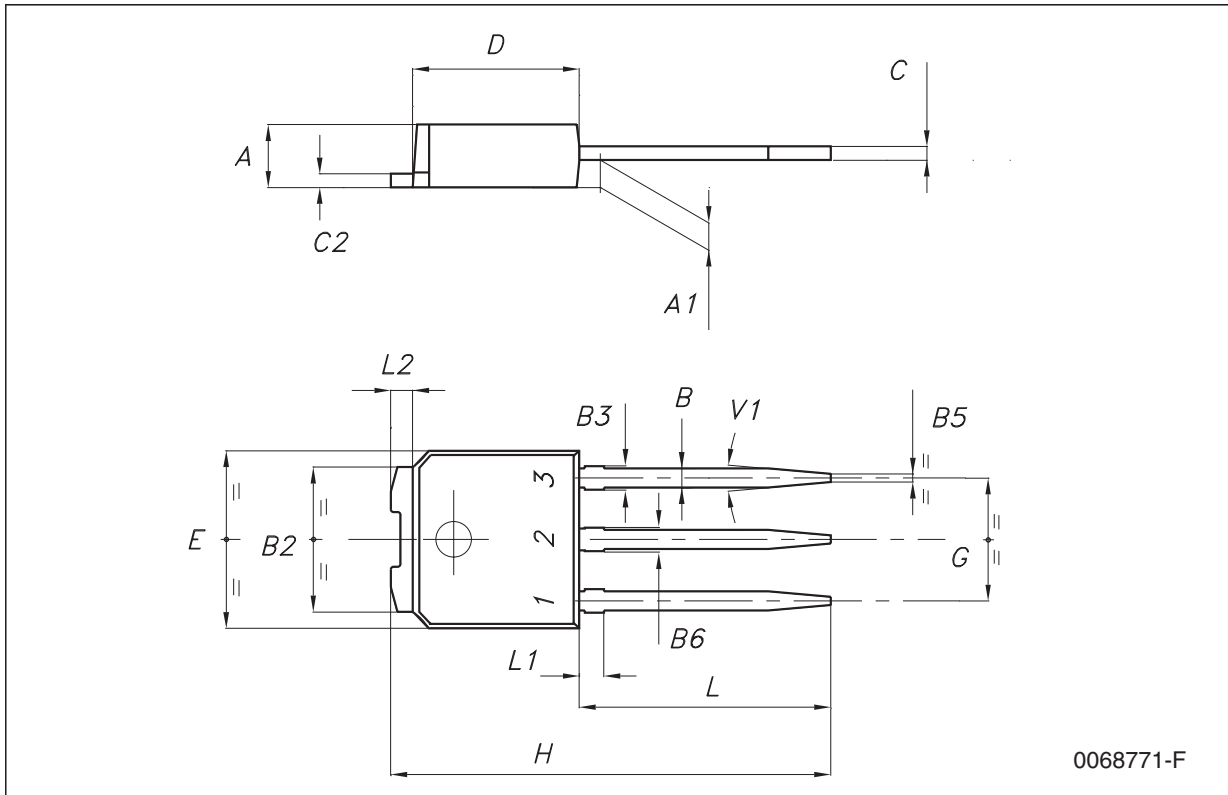

0068771-F

[查询"L78MXXC"供应商](#)

Tape & reel DPAK-PPAK mechanical data

Dim.	mm.			inch.		
	Min.	Typ.	Max.	Min.	Typ.	Max.
A			330			12.992
C	12.8	13.0	13.2	0.504	0.512	0.519
D	20.2			0.795		
N	60			2.362		
T			22.4			0.882
Ao	6.80	6.90	7.00	0.268	0.272	0.276
Bo	10.40	10.50	10.60	0.409	0.413	0.417
Ko	2.55	2.65	2.75	0.100	0.104	0.105
Po	3.9	4.0	4.1	0.153	0.157	0.161
P	7.9	8.0	8.1	0.311	0.315	0.319

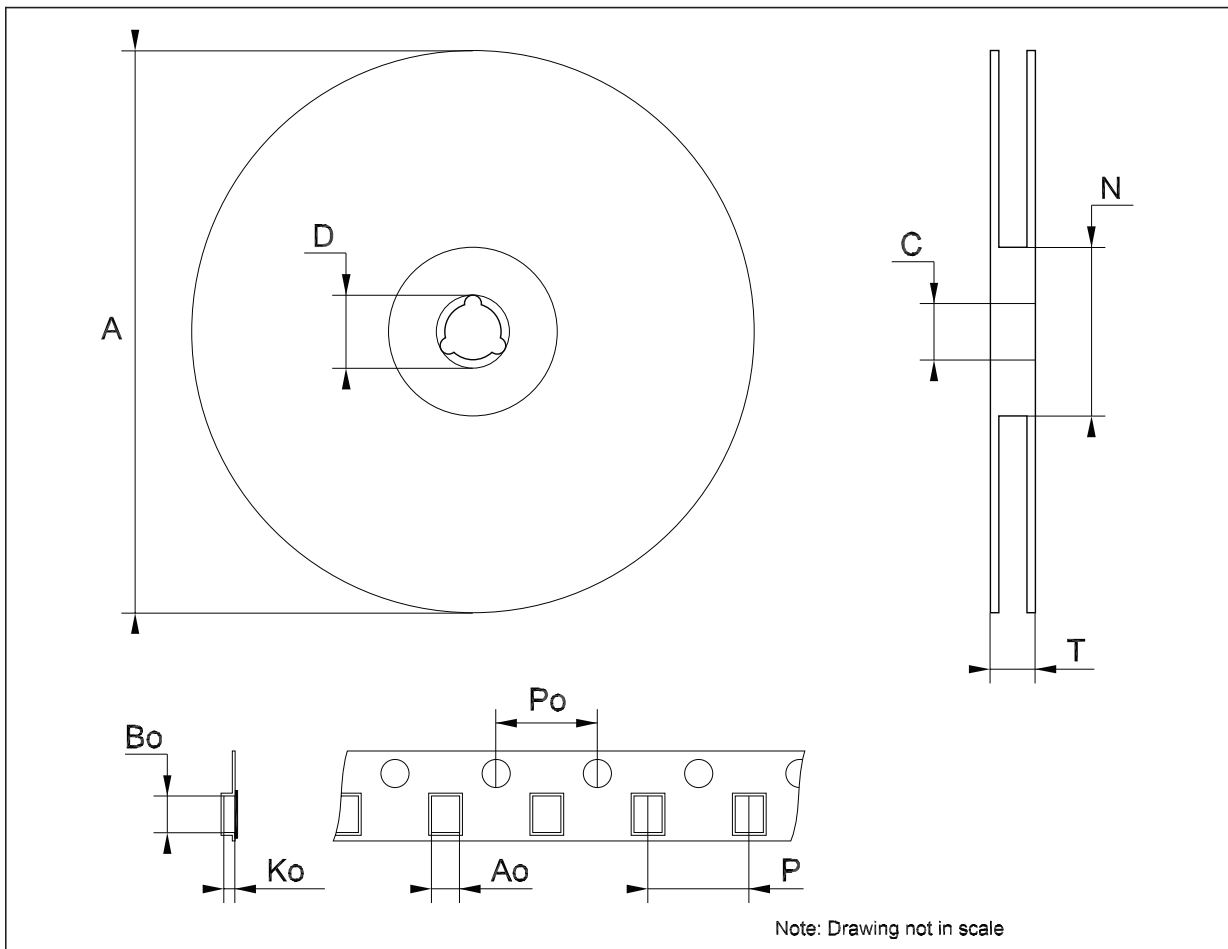

[查询"L78MXXC"供应商](#)**8 Order codes****Table 14. Order codes**

Packages				
TO-220	TO-220FP	DPAK	IPAK	Output voltage
L78M05CV	L78M05CP	L78M05CDT-TR	L78M05CDT-1	5 V
		L78M06CDT-TR	L78M06CDT-1 ⁽¹⁾	6 V
L78M08CV		L78M08CDT-TR	L78M08CDT-1 ⁽¹⁾	8 V
L78M09CV	L78M09CP	L78M09CDT-TR	L78M09CDT-1 ⁽¹⁾	9 V
L78M12CV		L78M12CDT-TR		12 V
L78M15CV		L78M15CDT-TR		15 V
		L78M18CDT-TR		18 V
L78M24CV	L78M24CP ⁽¹⁾	L78M24CDT-TR	L78M24CDT-1 ⁽¹⁾	24 V

1. Available on request

[查询"L78MXXC"供应商](#)

9 Revision history

Table 15. Document revision history

Date	Revision	Changes
21-Jun-2004	6	Document updating.
30-Aug-2006	7	Order codes has been updated and new template.
29-Nov-2006	8	DPAK mechanical data has been updated and add footprint data.
06-Jun-2007	9	Order codes has been updated.
10-Dec-2007	10	Added Table 1 .
19-Feb-2008	11	Modified: Table 1 on page 1 .

Please Read Carefully:

Information in this document is provided solely in connection with ST products. STMicroelectronics NV and its subsidiaries ("ST") reserve the right to make changes, corrections, modifications or improvements, to this document, and the products and services described herein at any time, without notice.

All ST products are sold pursuant to ST's terms and conditions of sale.

Purchasers are solely responsible for the choice, selection and use of the ST products and services described herein, and ST assumes no liability whatsoever relating to the choice, selection or use of the ST products and services described herein.

No license, express or implied, by estoppel or otherwise, to any intellectual property rights is granted under this document. If any part of this document refers to any third party products or services it shall not be deemed a license grant by ST for the use of such third party products or services, or any intellectual property contained therein or considered as a warranty covering the use in any manner whatsoever of such third party products or services or any intellectual property contained therein.

UNLESS OTHERWISE SET FORTH IN ST'S TERMS AND CONDITIONS OF SALE ST DISCLAIMS ANY EXPRESS OR IMPLIED WARRANTY WITH RESPECT TO THE USE AND/OR SALE OF ST PRODUCTS INCLUDING WITHOUT LIMITATION IMPLIED WARRANTIES OF MERCHANTABILITY, FITNESS FOR A PARTICULAR PURPOSE (AND THEIR EQUIVALENTS UNDER THE LAWS OF ANY JURISDICTION), OR INFRINGEMENT OF ANY PATENT, COPYRIGHT OR OTHER INTELLECTUAL PROPERTY RIGHT.

UNLESS EXPRESSLY APPROVED IN WRITING BY AN AUTHORIZED ST REPRESENTATIVE, ST PRODUCTS ARE NOT RECOMMENDED, AUTHORIZED OR WARRANTED FOR USE IN MILITARY, AIR CRAFT, SPACE, LIFE SAVING, OR LIFE SUSTAINING APPLICATIONS, NOR IN PRODUCTS OR SYSTEMS WHERE FAILURE OR MALFUNCTION MAY RESULT IN PERSONAL INJURY, DEATH, OR SEVERE PROPERTY OR ENVIRONMENTAL DAMAGE. ST PRODUCTS WHICH ARE NOT SPECIFIED AS "AUTOMOTIVE GRADE" MAY ONLY BE USED IN AUTOMOTIVE APPLICATIONS AT USER'S OWN RISK.

Resale of ST products with provisions different from the statements and/or technical features set forth in this document shall immediately void any warranty granted by ST for the ST product or service described herein and shall not create or extend in any manner whatsoever, any liability of ST.

ST and the ST logo are trademarks or registered trademarks of ST in various countries.

Information in this document supersedes and replaces all information previously supplied.

The ST logo is a registered trademark of STMicroelectronics. All other names are the property of their respective owners.

© 2008 STMicroelectronics - All rights reserved

STMicroelectronics group of companies

Australia - Belgium - Brazil - Canada - China - Czech Republic - Finland - France - Germany - Hong Kong - India - Israel - Italy - Japan - Malaysia - Malta - Morocco - Singapore - Spain - Sweden - Switzerland - United Kingdom - United States of America

www.st.com