

REVISIONS																			
LTR	DESCRIPTION	DATE (YR-MO-DA)	APPROVED																

REV																			
SHEET																			
REV																			
SHEET																			
REV STATUS OF SHEETS	REV																		
	SHEET	1	2	3	4	5	6	7	8	9									

PMIC N/A	PREPARED BY <i>Gary Galv</i>	DEFENSE ELECTRONICS SUPPLY CENTER DAYTON, OHIO 45444	
STANDARDIZED MILITARY DRAWING THIS DRAWING IS AVAILABLE FOR USE BY ALL DEPARTMENTS AND AGENCIES OF THE DEPARTMENT OF DEFENSE AMSC N/A	CHECKED BY <i>Charles E. Boyer</i>		
	APPROVED BY <i>William K. Heckman</i>		
	DRAWING APPROVAL DATE 15 AUGUST 1989	SIZE A	CAGE CODE 67268
REVISION LEVEL	SHEET 1		

DESC FORM 193
SEP 87

U.S. GOVERNMENT PRINTING OFFICE: 1987 - 748-129/60911
5962-E1270

DISTRIBUTION STATEMENT A. Approved for public release; distribution is unlimited.

1. SCOPE

1.1 Scope. This drawing describes device requirements for class B microcircuits in accordance with 1.2.1 of MIL-STD-883, "Provisions for the use of MIL-STD-883 in conjunction with compliant non-JAN devices".

1.2 Part number. The complete part number shall be as shown in the following example:

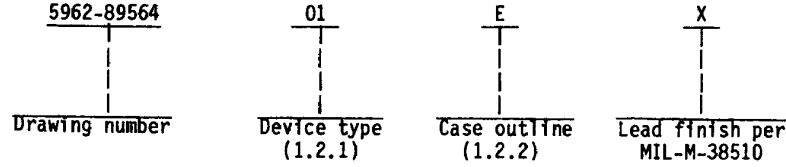

1.2.1 Device type. The device type shall identify the circuit function as follows:

Device type	Generic number	Circuit function
01	604A	High performance, low power FM IF system

1.2.2 Case outline. The case outline shall be as designated in appendix C of MIL-M-38510, and as follows:

Outline letter	Case outline
E	D-2 (16-lead, .840" x .310" x .200"), dual-in-line package

1.3 Absolute maximum ratings.

Supply voltage (V_{CC})	-----	9 V dc
Storage temperature range	-----	-65°C to +150°C
Power dissipation (P_D)	-----	100 mW
Lead temperature (soldering 10 seconds)	-----	+300°C
Thermal resistance, junction to case (θ_{JC})	-----	See MIL-M-38510, appendix C
Thermal resistance, junction to ambient (θ_{JA})	-----	100°C/W
Junction temperature (T_J)	-----	175°C

1.4 Recommended operating conditions.

Supply voltage (V_{CC})	-----	6 V dc
Ambient operating temperature range (T_A)	-----	-55°C to +125°C

STANDARDIZED MILITARY DRAWING DEFENSE ELECTRONICS SUPPLY CENTER DAYTON, OHIO 45444	SIZE A	5962-89564
	REVISION LEVEL	SHEET 2

<p>2. APPLICABLE DOCUMENTS</p> <p>2.1 Government specification, standard, and bulletin. Unless otherwise specified, the following specification, standard, and bulletin of the issue listed in that issue of the Department of Defense Index of Specifications and Standards specified in the solicitation, form a part of this drawing to the extent specified herein.</p> <p>SPECIFICATION</p> <p>MILITARY</p> <p>MIL-M-38510 - Microcircuits, General Specification for.</p> <p>STANDARD</p> <p>MILITARY</p> <p>MIL-STD-883 - Test Methods and Procedures for Microelectronics.</p> <p>BULLETIN</p> <p>MILITARY</p> <p>MIL-BUL-103 - List of Standardized Military Drawings (SMD's).</p> <p>(Copies of the specification, standard, and bulletin required by manufacturers in connection with specific acquisition functions should be obtained from the contracting activity or as directed by the contracting activity.)</p> <p>2.2 Order of precedence. In the event of a conflict between the text of this drawing and the references cited herein, the text of this drawing shall take precedence.</p> <p>3. REQUIREMENTS</p> <p>3.1 Item requirements. The individual item requirements shall be in accordance with 1.2.1 of MIL-STD-883, "Provisions for the use of MIL-STD-883 in conjunction with compliant non-JAN devices" and as specified herein.</p> <p>3.2 Design, construction, and physical dimensions. The design, construction, and physical dimensions shall be as specified in MIL-M-38510 and herein.</p> <p>3.2.1 <u>Terminal connections.</u> The terminal connections shall be as specified on figure 1.</p> <p>3.2.2 <u>Case outline.</u> The case outline shall be in accordance with 1.2.2 herein.</p> <p>3.3 <u>Electrical performance characteristics.</u> Unless otherwise specified, the electrical performance characteristics are as specified in table I and apply over the full ambient operating temperature range.</p> <p>3.4 <u>Electrical test requirements.</u> The electrical test requirements shall be the subgroups specified in table II. The electrical tests for each subgroup are as described in table I.</p> <p>3.5 <u>Marking.</u> Marking shall be in accordance with MIL-STD-883 (see 3.1 herein). The part shall be marked with the part number listed in 1.2 herein. In addition, the manufacturer's part number may also be marked as listed in MIL-BUL-103 (see 6.6 herein).</p>			
<p>STANDARDIZED MILITARY DRAWING</p> <p>DEFENSE ELECTRONICS SUPPLY CENTER DAYTON, OHIO 45444</p>	<p>SIZE A</p>		<p>5962-89564</p>
		<p>REVISION LEVEL</p>	<p>SHEET 3</p>

TABLE I. Electrical performance characteristics.

Test	Symbol	Conditions -55°C < T _A < +125°C V _{CC} = 6 V (see figure 2)	Group A subgroups	Limits		Unit
				Min	Max	
Power supply voltage range	V _{CC}		1, 2, 3	4.5	8.0	V
DC current drain	I _{CC}		1, 2, 3		4.2	mA
Mute switch input threshold	ON	V _{THH}	1, 2, 3	1.7		V
	OFF	V _{THL}	1, 2, 3		1.0	V
AM rejection		80% AM at 1 kHz	4, 5, 6	-20		dB
Total harmonic distortion	T _{HD}		4, 5, 6	-25		dB
RSSI output	R _{SSI}	RF level = -97 dBm	4, 5, 6	0	600	mV
		RF level = -47 dBm	4, 5, 6	1.8	3.2	V
		RF level = +3 dBm	4, 5, 6	3.5	5.5	V
IF input impedance	R _{IN}	2/	4, 5, 6	1.5		kΩ
IF output impedance	R _{OUT}	2/	4, 5, 6	1.0		kΩ
Limited output impedance	L _R OUT	2/	4, 5, 6	1.5		kΩ
Recovered audio level		15 nF de-emphasis	4, 5, 6	60		mV rms

1/ IF frequency = 455 kHz, IF level = -47 dBm, FM modulation = 1 kHz with ±8 kHz peak deviation. Audio output with C-message weighted filter and de-emphasis capacitor. The parameters listed are tested using automatic test equipment to assure consistent electrical characteristics. The limits do not represent the ultimate performance limits of the device. Use of an optimized RF layout will improve many of the listed parameters.

2/ These parameters, if not tested, shall be guaranteed to the limits specified in table I.

STANDARDIZED MILITARY DRAWING DEFENSE ELECTRONICS SUPPLY CENTER DAYTON, OHIO 45444	SIZE A		5962-89564
		REVISION LEVEL	SHEET 4

DESC FORM 193A
SEP 87

* U. S. GOVERNMENT PRINTING OFFICE: 1988-549-904

Device type	01
Case outline	E
Terminal number	Terminal symbol
1	IF AMP DECOUPLING
2	GND
3	MUTE INPUT
4	V _{CC}
5	RSSI OUTPUT
6	MUTED AUDIO OUTPUT
7	UNMUTED AUDIO OUTPUT
8	QUADRATURE INPUT
9	LIMITER OUTPUT
10	LIMITER DECOUPLING
11	LIMITER DECOUPLING
12	LIMITER INPUT
13	GND
14	IF AMP OUTPUT
15	IF AMP DECOUPLING
16	IF AMP OUTPUT

FIGURE 1. Terminal connections.

STANDARDIZED MILITARY DRAWING DEFENSE ELECTRONICS SUPPLY CENTER DAYTON, OHIO 45444	SIZE A		5962-89564
		REVISION LEVEL	SHEET 5

DESC FORM 193A
SEP 87

☆ U. S. GOVERNMENT PRINTING OFFICE: 1988-549-904

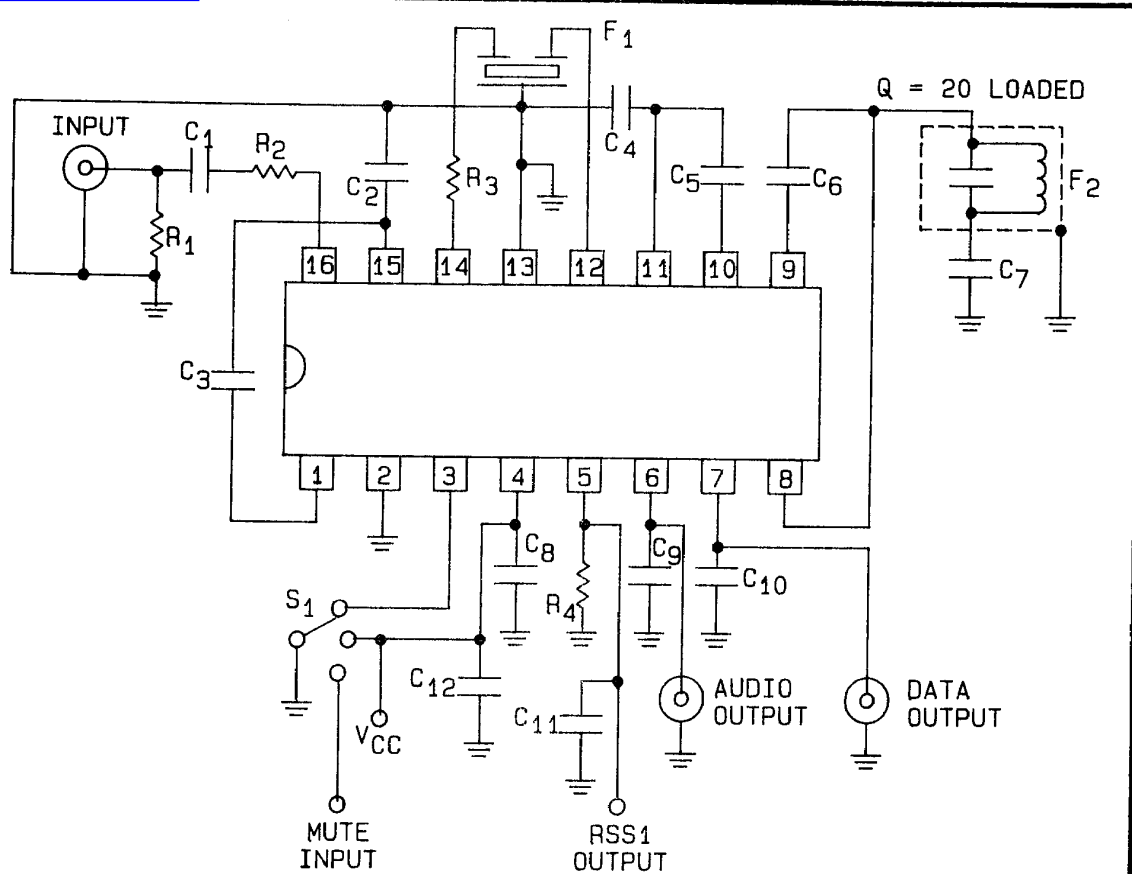

- C1 - 10 nF (+80 - 20% = 63 V) K1000 Z5V ceramic
- C2, C3, C4, C5 - 100 nF ±10% 50 V polystyrene
- C6 - 10 pF ±2% 100 V NPO ceramic
- C7, C8 - 100 nF ±10% 50 V polystyrene
- C9 - 15 nF ±10% 50 V polystyrene
- C10 - 150 pF ±2% 100 V N1500 ceramic
- C11 - 1 nF ±10% 100 V K2000 Y5P ceramic
- C12 - 6.8 μF ±20% 25 V tantalum
- F1 - 455 kHz ceramic filter Murata SFG 455A3
- F2 - 455 kHz IF filter A2549
- R1 - 51Ω ±1% 1/4 W metal film
- R2 - 1500Ω ±1% 1/4 W metal film
- R3 - 1500Ω ±5% 1/8 W carbon composition
- R4 - 100 kΩ ±1% 1/4 W metal film

FIGURE 2. Test circuit for static and dynamic tests.

STANDARDIZED MILITARY DRAWING DEFENSE ELECTRONICS SUPPLY CENTER DAYTON, OHIO 45444	SIZE A	5962-89564	
		REVISION LEVEL	SHEET 6

DESC FORM 193A
SEP 87

U. S. GOVERNMENT PRINTING OFFICE: 1986-549-904

3.6 Certificate of compliance. A certificate of compliance shall be required from a manufacturer in order to be listed as an approved source of supply in MIL-BUL-103 (see 6.6). The certificate of compliance submitted to DESC-ECS prior to listing as an approved source of supply shall state that the manufacturer's product meets the requirements of MIL-STD-883 (see 3.1 herein) and the requirements herein.

3.7 Certificate of conformance. A certificate of conformance as required in MIL-STD-883 (see 3.1 herein) shall be provided with each lot of microcircuits delivered to this drawing.

3.8 Notification of change. Notification of change to DESC-ECS shall be required in accordance with MIL-STD-883 (see 3.1 herein).

3.9 Verification and review. DESC, DESC's agent, and the acquiring activity retain the option to review the manufacturer's facility and applicable required documentation. Offshore documentation shall be made available onshore at the option of the reviewer.

4. QUALITY ASSURANCE PROVISIONS

4.1 Sampling and inspection. Sampling and inspection procedures shall be in accordance with section 4 of MIL-M-38510 to the extent specified in MIL-STD-883 (see 3.1 herein).

4.2 Screening. Screening shall be in accordance with method 5004 of MIL-STD-883, and shall be conducted on all devices prior to quality conformance inspection. The following additional criteria shall apply:

a. Burn-in test, method 1015 of MIL-STD-883.

(1) Test condition A using the circuit submitted with the certificate of compliance (see 3.6 herein).

(2) $T_A = +125^\circ\text{C}$, minimum.

b. Interim and final electrical test parameters shall be as specified in table II herein, except interim electrical parameter tests prior to burn-in are optional at the discretion of the manufacturer.

4.3 Quality conformance inspection. Quality conformance inspection shall be in accordance with method 5005 of MIL-STD-883 including groups A, B, C, and D inspections. The following additional criteria shall apply.

4.3.1 Group A inspection.

a. Tests shall be as specified in table II herein.

b. Subgroups 7, 8, 9, 10, and 11 in table I, method 5005 of MIL-STD-883 shall be omitted.

4.3.2 Groups C and D inspections.

a. End-point electrical parameters shall be as specified in table II herein.

b. Steady-state life test conditions, method 1005 of MIL-STD-883:

(1) Test condition A using the circuit submitted with the certificate of compliance (see 3.6 herein).

(2) $T_A = +125^\circ\text{C}$, minimum.

(3) Test duration: 1,000 hours, except as permitted by method 1005 of MIL-STD-883.

STANDARDIZED MILITARY DRAWING DEFENSE ELECTRONICS SUPPLY CENTER DAYTON, OHIO 45444	SIZE A		5962-89564
		REVISION LEVEL	SHEET 7

DESC FORM 193A
SEP 87

TABLE II. Electrical test requirements.

MIL-STD-883 test requirements	Subgroups (per method 5005, table I)
Interim electrical parameters (method 5004)	---
Final electrical test parameters (method 5004)	1*,2,3,4,5,6
Group A test requirements (method 5005)	1,2,3,4,5,6
Groups C and D end-point electrical parameters (method 5005)	1,2,3

* PDA applies to subgroup 1.

5. PACKAGING

5.1 Packaging requirements. The requirements for packaging shall be in accordance with MIL-M-38510.

6. NOTES

6.1 Intended use. Microcircuits conforming to this drawing are intended for use when military specifications do not exist and qualified military devices that will perform the required function are not available for OEM application. When a military specification exists and the product covered by this drawing has been qualified for listing on QPL-38510, the device specified herein will be inactivated and will not be used for new design. The QPL-38510 product shall be the preferred item for all applications.

6.2 Replaceability. Microcircuits covered by this drawing will replace the same generic device covered by a contractor-prepared specification or drawing.

6.3 Configuration control of SMD's. All proposed changes to existing SMD's will be coordinated with the users of record for the individual documents. This coordination will be accomplished in accordance with MIL-STD-481 using DD Form 1693, Engineering Change Proposal (Short Form).

6.4 Record of users. Military and industrial users shall inform Defense Electronics Supply Center when a system application requires configuration control and the applicable SMD. DESC will maintain a record of users and this list will be used for coordination and distribution of changes to the drawings. Users of drawings covering microelectronics devices (FSC 5962) should contact DESC-ECS, telephone 513-296-6022.

6.5 Comments. Comments on this drawing should be directed to DESC-ECS, Dayton, Ohio 45444, or telephone 513-296-5375.

STANDARDIZED MILITARY DRAWING DEFENSE ELECTRONICS SUPPLY CENTER DAYTON, OHIO 45444	SIZE A	5962-89564
	REVISION LEVEL	SHEET 8

DESC FORM 193A
SEP 87

查询"5962-8956401EA"供应商

3.6 Approved source of supply. An approved source of supply is listed in MIL-BUL-103. Additional sources will be added to MIL-BUL-103 as they become available. The vendor listed in MIL-BUL-103 has agreed to this drawing and a certificate of compliance (see 3.6 herein) has been submitted to and accepted by DESC-ECS. The approved source of supply listed below is for information purposes only and is current only to the date of the last action of this document.

Military drawing part number	Vendor CAGE number	Vendor similar part number <u>1/</u>
5962-8956401EX	18324	604A/BEA

1/ Caution. Do not use this number for item acquisition. Items acquired to this number may not satisfy the performance requirements of this drawing.

Vendor CAGE number

18324

Vendor name and address

Signetics Corporation
4130 South Market Court
Sacramento, CA 95834

STANDARDIZED MILITARY DRAWING DEFENSE ELECTRONICS SUPPLY CENTER DAYTON, OHIO 45444	SIZE A		5962-89564
		REVISION LEVEL	SHEET 9

DESC FORM 193A
SEP 87

U. S. GOVERNMENT PRINTING OFFICE: 1988-549-904