

## CLC730145, CLC730132 (SOIC and TSSOP) Quad High-Speed Buffer Evaluation Boards

### General Description

The CLC730145 and the CLC730132 evaluation boards are designed to aid in the characterization of National Semiconductor's High Speed SOIC and TSSOP buffers. Use these evaluation boards as a guide for high frequency layout and as a tool to aid in device testing and characterization. The evaluation boards schematic are shown in *Figure 1* and *Figure 2*. Refer to the product data sheets for recommendations for component values.

### Basic Operation

These boards are a very straight forward design and are intended to evaluate the parts behavior by offering 50Ω inputs and outputs traces for connection to coaxial cables with the same impedance. For other impedances the terminating resistors can be modified to help match different impedances. Both board and part are designed to handle very high frequencies. By changing the resistor connected to the input pin and ground the input impedance can be matched but keep in mind that the input trace is designed for 50Ω. By using e.g. 75Ω impedance, the results will be noticeably different especially for the highest frequencies. Also at the output it is possible to match different impedances but the output trace is designed for 50Ω. With the series resistor at the output the output cable can be matched, however this is not necessary. It is absolutely necessary to have the impedance at the end of the connected cable matched to the cable impedance but not the resistor at the beginning. Having the output series resistor matched to the cable impedance gives only an additional attenuation of -6dB. The SMA connectors are optimized for 50Ω operation. Even with optimal layout, board parasitics play a large part in high frequency performance and different termination resistors will change the frequency of the dominant parasitic poles/zeros.

### Layout Considerations

Printed circuit board layout and supply bypassing play major roles in determining high frequency performance. When designing your own board use these evaluation boards as a guide and follow these steps to optimize high frequency performance:

- Use a ground plane
- Include large (10μF) capacitors on both supplies.
- Near the device use 10nF ceramic capacitors from both supplies to ground.
- Near the device use a 0.1μF ceramic capacitor between the supplies.

- Minimize all trace lengths
- Terminated always all transmission lines used.

The capacitor between both supplies is recommended for best 2nd Harmonic Distortion performance. The zener diode between both supplies protect the device from reverse polarity supply connections under the condition these supplies have the current limitation on. Most high-speed buffers perform best with capacitive loads if a small resistor is used in series between the amplifier and the capacitor. In that case, change the output series resistor to a value of about 10Ω and evaluate what the output signal will do. Determine the right value by trial and error. While using rather high capacitive loads the matching at the output become less important because the frequency response will be dramatically lower, so a flat response will be more important. See the part's datasheets for recommended values. Sample artwork for the CLC730145 and the CLC730132 Evaluation boards is included on *Figure 3*.

### Measurement Hints

The test board offers the customer two channels out of the four buffers connected to SMA connectors. This includes the possibility for doing measurements on cross talk and gain matching. Furthermore it is not recommended to use normal oscilloscope probes to test these circuits, especially when measuring the highest frequency regions the part is active. The capacitive loading will change circuit performance drastically. Instead use high frequency low ohmic passive probes. These probes have a load resistance in the range of several hundred ohms until some kΩ. For best performance use ground leads as short as possible otherwise ringing on pulse shaped signals will occur. The use of active probes gives also good results if basic rules are obtained, such as the short ground leads. Another good idea to isolate the load from the device is to change the output series resistor to a value of 450Ω. While measuring with a coaxial cable in a 50Ω system an attenuation of 10x (20dB) will occur and this acts as a resistive probe of 10:1. Even the best probes will interfere with circuit operation to some degree. Also, tools, power cables, fingers etc. near the device will change measurement results. If the circuit has a good layout and therefore exhibits a stable behavior the measurement results will only slightly changed by e.g. a fingertip on the circuit. If measurement results will change dramatically it is likely the circuit exhibits oscillations or other unwanted behavior.

Board Schematics

查询CLC730145供应商

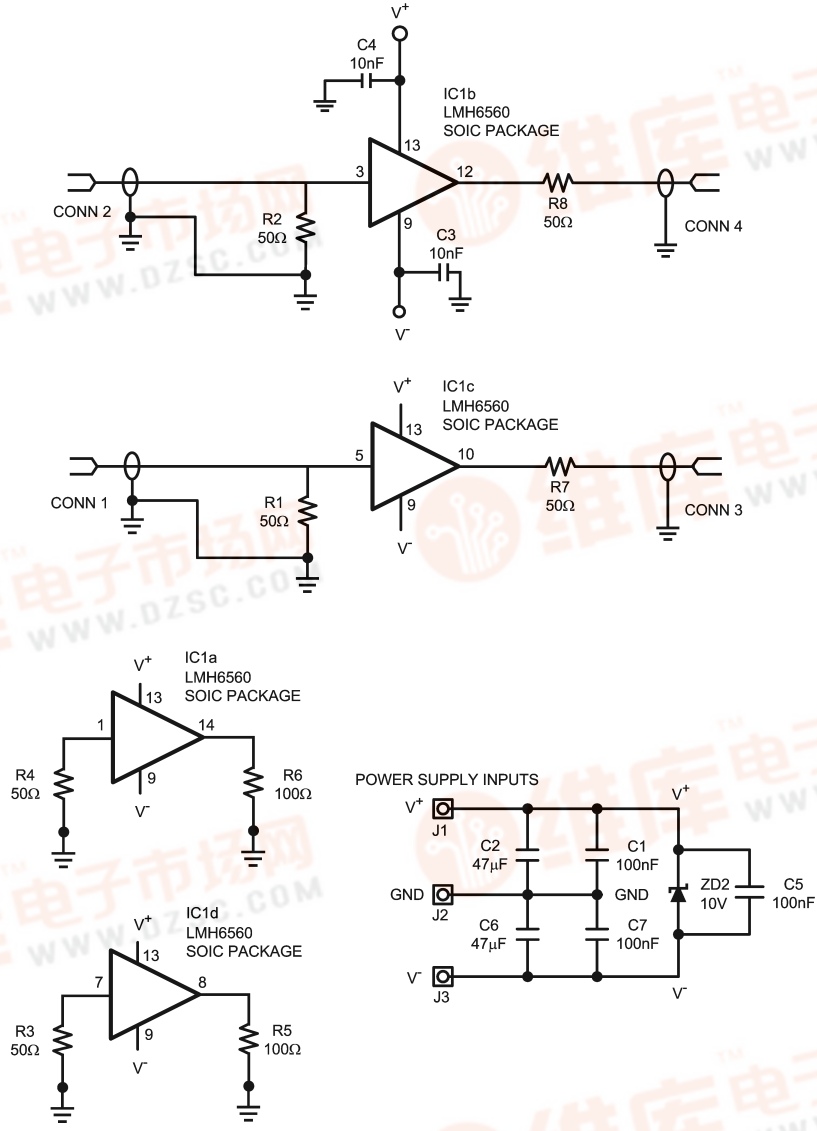

FIGURE 1. Test Board Schematic SOIC (CLC730145)



Board Schematics (Continued)

[查询CLC730145供应商](#)

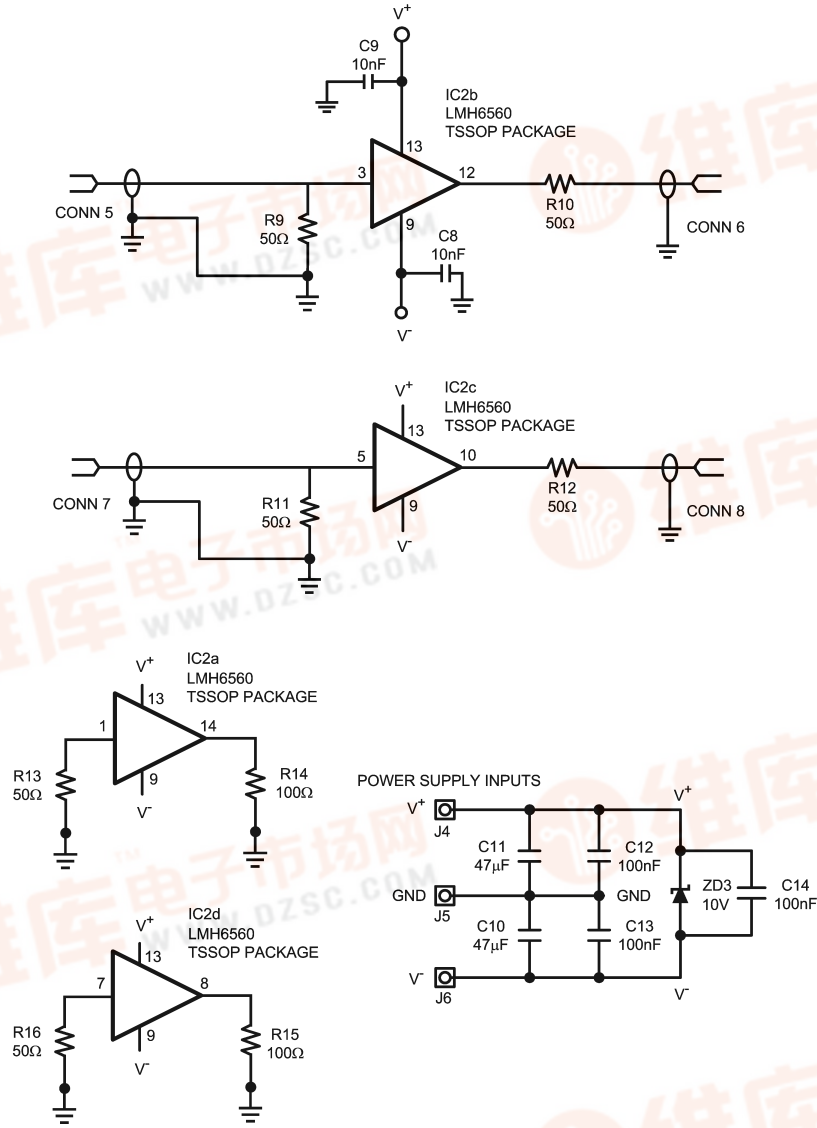
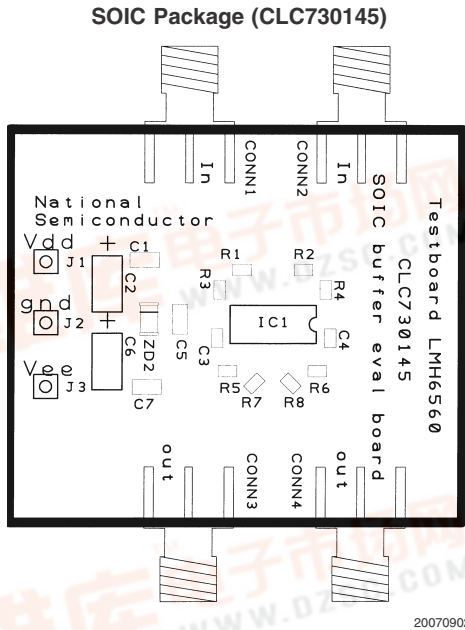

FIGURE 2. Test Board Schematic TSSOP (CLC730132)

20070908



Board Layout  
[CLC730145 供应商](#)



20070902

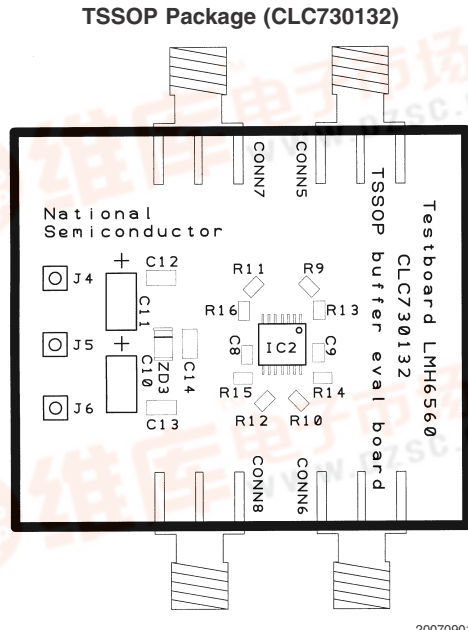

20070901

Top Silk

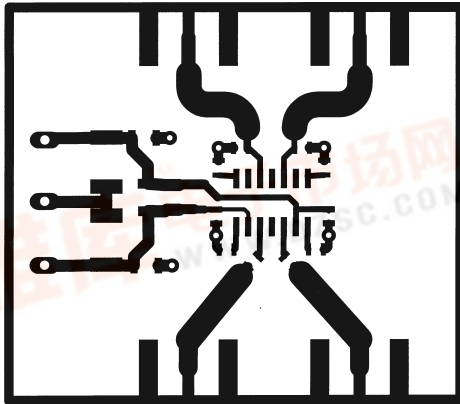

20070904

Top Silk

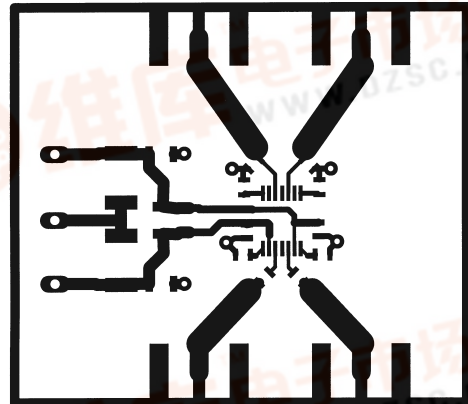

20070903

Top Copper

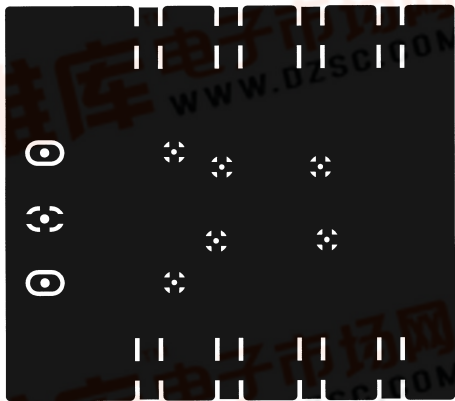

20070905

Top Copper

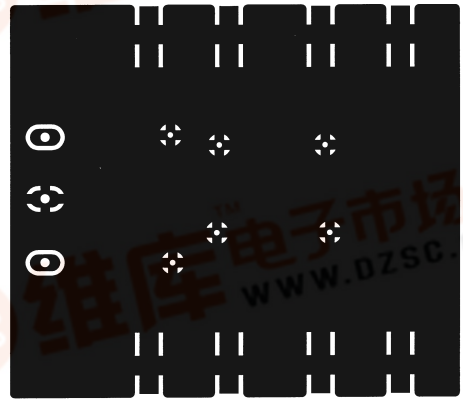

20070906

Bottom Copper



Bottom Copper



FIGURE 3. Test Board Lay-Outs



## Notes

[查询CLC730145供应商](#)**LIFE SUPPORT POLICY**

NATIONAL'S PRODUCTS ARE NOT AUTHORIZED FOR USE AS CRITICAL COMPONENTS IN LIFE SUPPORT DEVICES OR SYSTEMS WITHOUT THE EXPRESS WRITTEN APPROVAL OF THE PRESIDENT AND GENERAL COUNSEL OF NATIONAL SEMICONDUCTOR CORPORATION. As used herein:

1. Life support devices or systems are devices or systems which, (a) are intended for surgical implant into the body, or (b) support or sustain life, and whose failure to perform when properly used in accordance with instructions for use provided in the labeling, can be reasonably expected to result in a significant injury to the user.
2. A critical component is any component of a life support device or system whose failure to perform can be reasonably expected to cause the failure of the life support device or system, or to affect its safety or effectiveness.



**National Semiconductor**  
Americas Customer  
Support Center  
Email: new.feedback@nsc.com  
Tel: 1-800-272-9959

www.national.com

**National Semiconductor**  
Europe Customer Support Center  
Fax: +49 (0) 180-530 85 86  
Email: europe.support@nsc.com  
Deutsch Tel: +49 (0) 69 9508 6208  
English Tel: +44 (0) 870 24 0 2171  
Français Tel: +33 (0) 1 41 91 8790

**National Semiconductor**  
Asia Pacific Customer  
Support Center  
Email: ap.support@nsc.com

**National Semiconductor**  
Japan Customer Support Center  
Fax: 81-3-5639-7507  
Email: jpn.feedback@nsc.com  
Tel: 81-3-5639-7560

