

# LM3405 Demo Board

[查询LM3405供应商](#)

National Semiconductor  
Application Note 1590  
Alex Gao  
March 2007



## Introduction

The LM3405 demo board is configured to drive a series string of high power, high brightness LEDs at a forward current of 1A using the LM3405 constant current buck regulator. The board can accept a full input operating range of 3V to 15V. The converter output voltage adjusts as needed to maintain a constant current through the LED array. The LM3405 is a step-down regulator with an output voltage range extending from a  $V_{O(MIN)}$  of 205mV (the reference voltage) to a  $V_{O(MAX)}$  determined by the maximum duty cycle (typically 94%). It can drive up to 3 LEDs in series at 1A forward current, with the single LED forward voltage of approximately 3.7V (Typical of white, blue, and green LEDs using InGaN technology).

As shown in the demo board schematic circuit in *Figure 1*, the board is configured with the boost voltage derived from  $V_{IN}$  through a shunt zener (D3). This will ensure that the gate drive voltage  $V_{BOOST} - V_{SW}$  falls in the recommended range of 2.5V to 5.5V when  $V_{IN}$  varies from 5V to 15V. In cases of low input voltages (3V to 5V) being used, the boost diode (D2) can be directly connected to  $V_{IN}$  (R3 short, C4 and D3 not installed) to obtain sufficient gate drive voltage for best performance.

*Table 1* lists the bill of materials of this demo board. The measured performance characteristics and layout of this board are also included below. Additional Circuit Configuration Schematics section illustrates other possible circuit configurations of this board to accommodate various input and output requirements as discussed in the LM3405 datasheet.

## Connecting to LED Array

The LM3405 Demo Board includes a female 6-position SIP connector **P1** as well as two standard 72mil turret connectors

for the cathode and anode connections of the LED array. Solid 18 or 20 gauge wire with about 1cm of insulation stripped away makes a convenient, solderless connection to **P1**.

## Setting the LED Current

The default forward current  $I_F$  delivered to the LED array is 1.0A. To adjust this value the current setting resistor R1 can be changed according to the following equation:

$$I_F = V_{FB} / R1$$

The feedback voltage  $V_{FB}$  is regulated at 0.205V typically. The resistor R1 should be rated to handle the power dissipation of the LED current. R1 should be less than approximately  $1\Omega$ , to ensure that the LED current is kept above 200mA. If average LED currents of less than 200mA are desired, the EN/DIM pin should be used for PWM dimming.

## PWM Dimming

The default connection of the PWM terminal is tied to  $V_{IN}$  through a 100k $\Omega$  resistor (R2) to enable the chip, which allows the set current to flow through the LEDs continuously. This PWM terminal can also be connected separately to a periodic pulse signal at different frequencies and/or duty cycle for PWM dimming. A typical LED current waveform in PWM dimming mode is shown in *Figure 2*. *Figure 3* shows the average LED current versus duty cycle of PWM dimming signal for various frequencies. Due to an approximately 100 $\mu$ s delay between the dimming signal and LED current, the dimming ratio reduces dramatically if the applied PWM dimming frequency is greater than 5kHz.

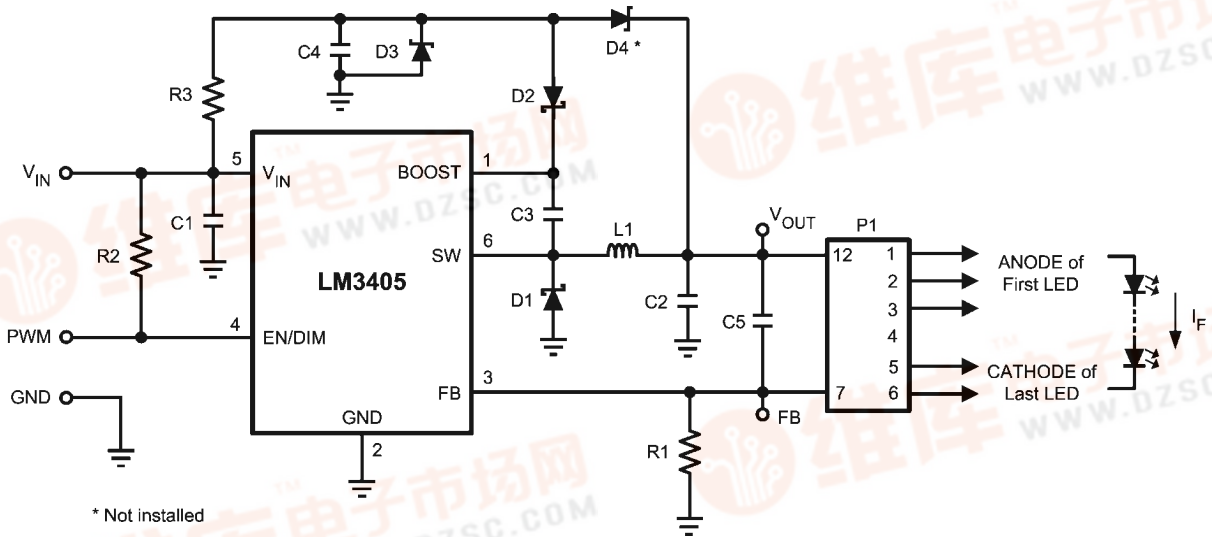
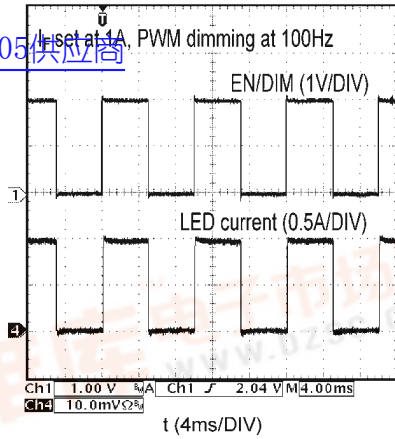

FIGURE 1. LM3405 Demo Board Schematic

30010001

查询LM3405供应商



30010002

FIGURE 2. PWM Dimming of LEDs

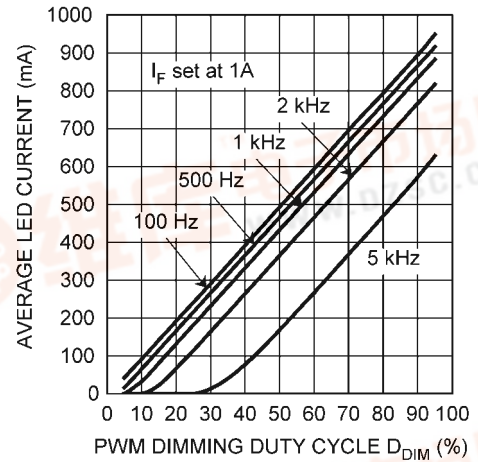

30010003

FIGURE 3. Average LED Current versus Duty Cycle of PWM Dimming Signal at PWM Terminal

TABLE 1. Bill of Materials

Part ID	Part Value	Part Number	Manufacturer
U1	1A constant current buck regulator, TSOT-6	LM3405	National Semiconductor
L1	6.8 $\mu$ H, 1.5A, 35m $\Omega$ , 6.0 x 6.0 x 2.8mm	SLF6028T-6R8M1R5-PF	TDK
C1	10 $\mu$ F, 25V, X5R, 1206	GRM31CR61E106KA12L	Murata
C2	1 $\mu$ F, 25V, X7R, 1206	C1206C105K3RACTU	Kemet
C3	0.01 $\mu$ F, 16V, X7R, 0805	0805YC103KAT2A	AVX
C4	0.1 $\mu$ F, 16V, X7R, 0805	GRM219R71C104KA01D	Murata
C5	1 $\mu$ F, 25V, X5R, 0805	GRM216R61E105KA12D	Murata
D1	Schottky, 30V, 1A, SMA	MBRA130LT3G	ON Semiconductor
D2	Schottky, 30V, 200mA, SOD-323	BAT54WS-TP	Micro Commercial Co.
D3	5.1V, 0.35W, SOT23	BZX84C5V1	Fairchild Semiconductor
D4	Not installed		
R1	0.5W, 0.2 $\Omega$ , 1%, 2010	WSL2010R2000FEA	Vishay
R2	100k $\Omega$ , 1/8W, 1%, 0805	CRCW0805100KFKEA	Vishay
R3	1.0k $\Omega$ , 1%, 1/8W, 0805	CRCW08051K00FKEA	Vishay
P1	6-position connector	5535676-5	Tyco/AMP

# Typical Performance Characteristics

[查询LM3405供应商](#)

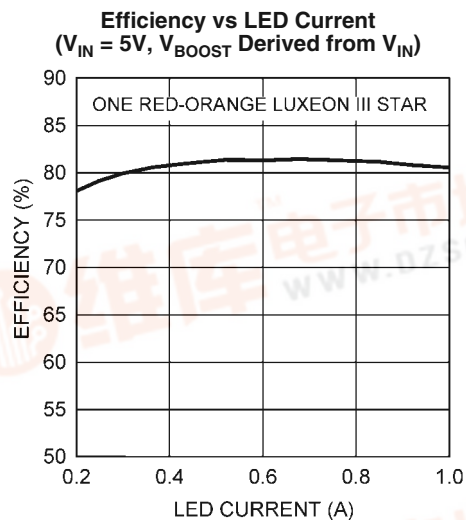

30010004

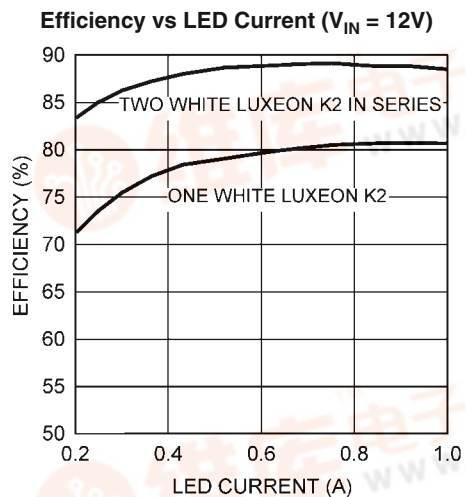

30010005

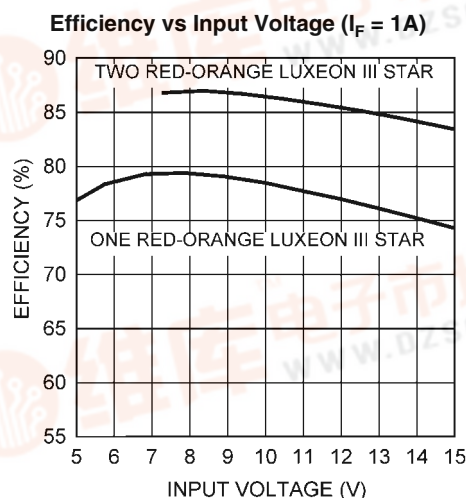

30010006

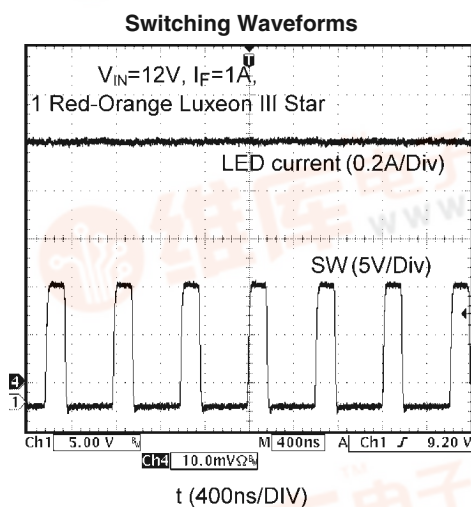

30010007

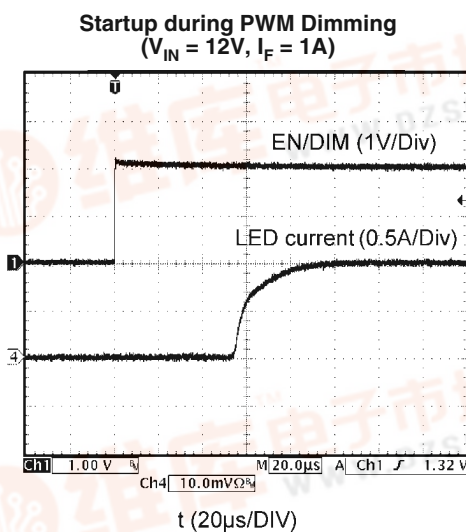

30010008

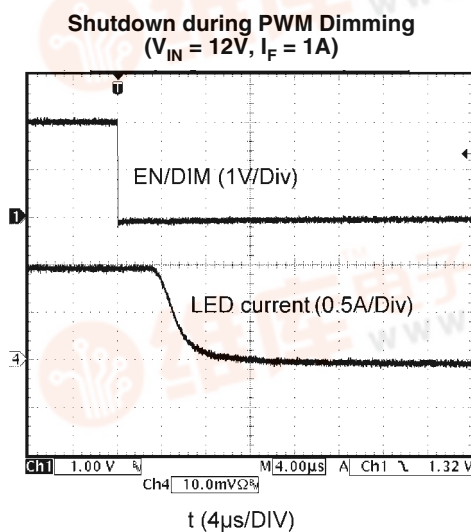

30010009



# Layout

[查询LM3405供应商](#)

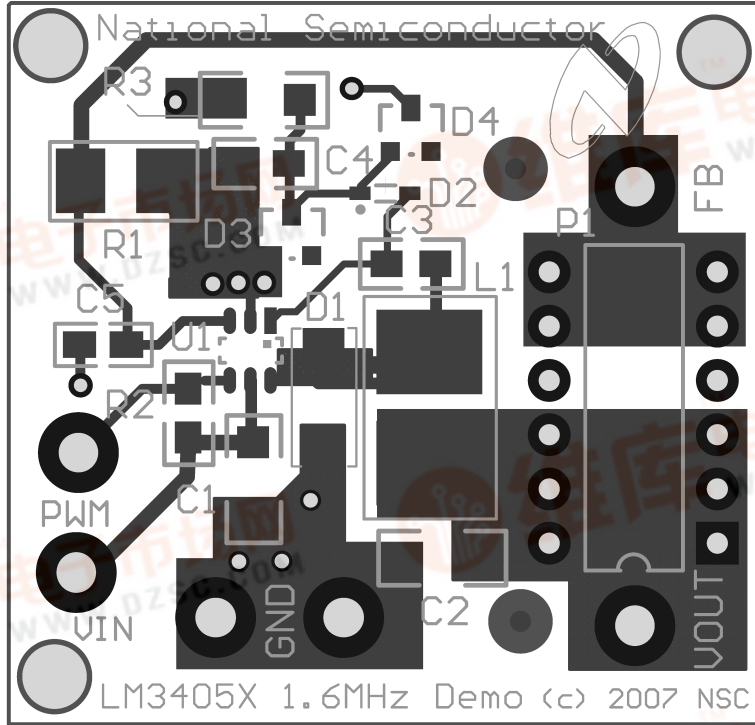

Top Layer and Top Overlay

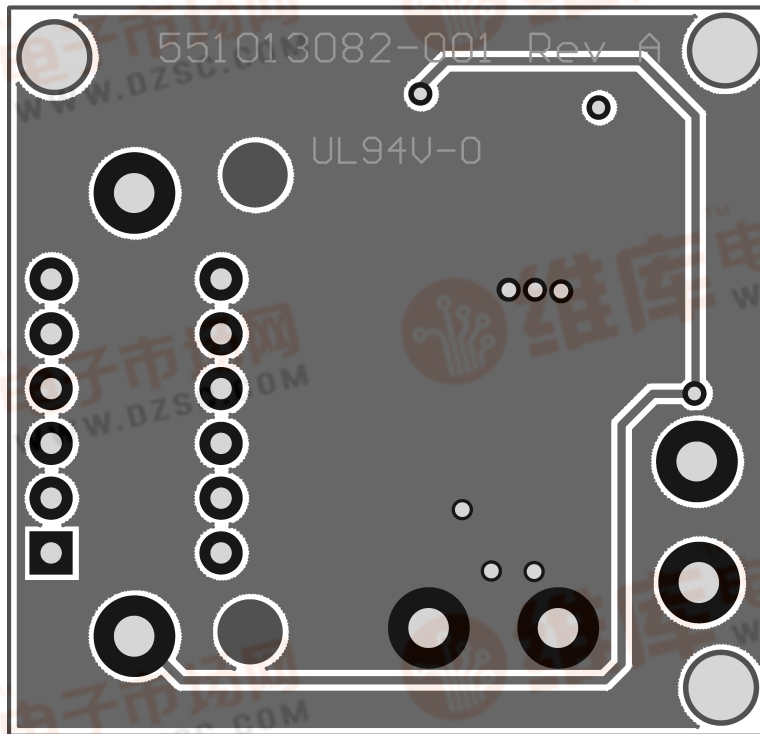

Bottom Layer and Bottom Overlay





[查询LM3405供应商](#)

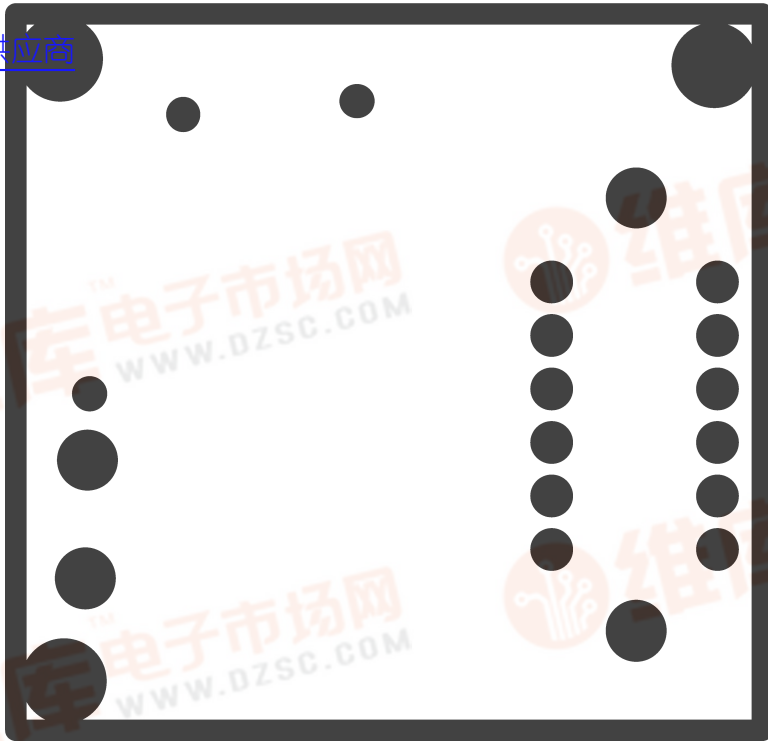

Internal Plane 1 (GND)

30010012

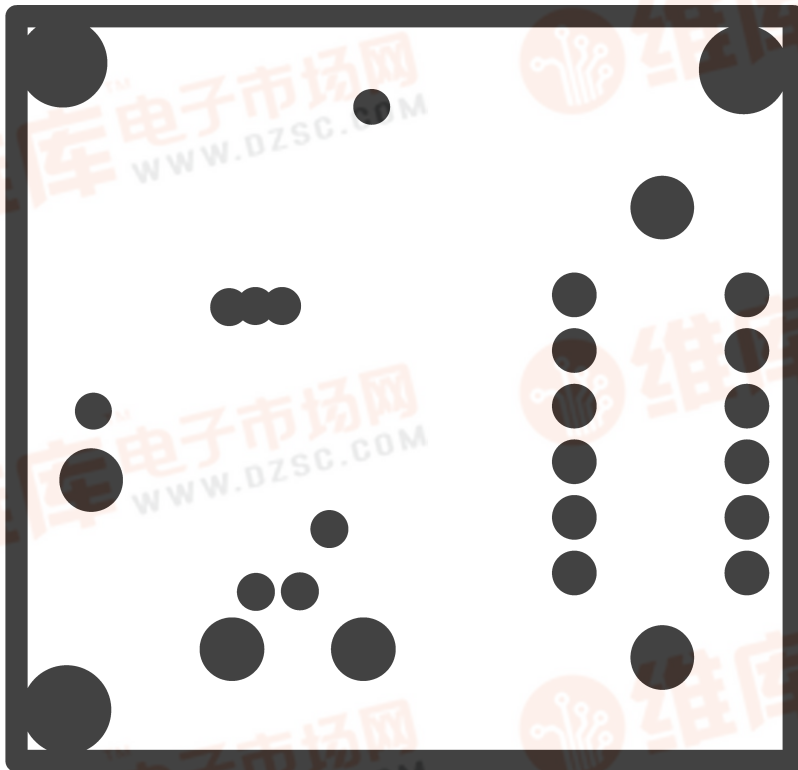

Internal Plane 2 (V<sub>IN</sub>)

30010013

# Additional Circuit Configuration Schematics

[查询LM3405供应商](#)

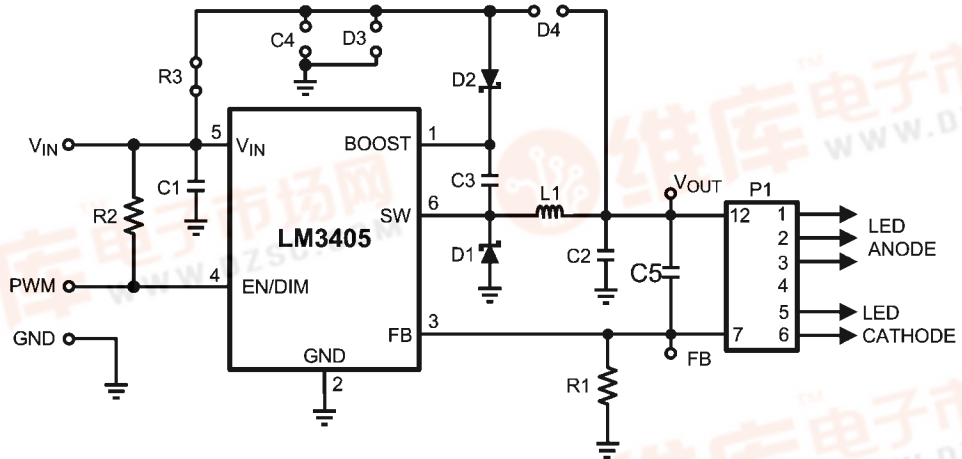

$V_{BOOST}$  Derived from  $V_{IN}$

30010014

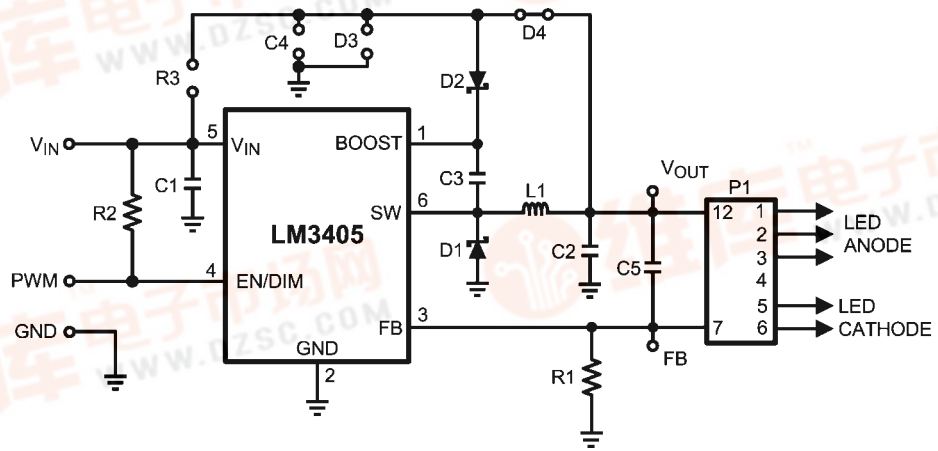

$V_{BOOST}$  Derived from  $V_{OUT}$

30010015



[查询LM3405供应商](#)

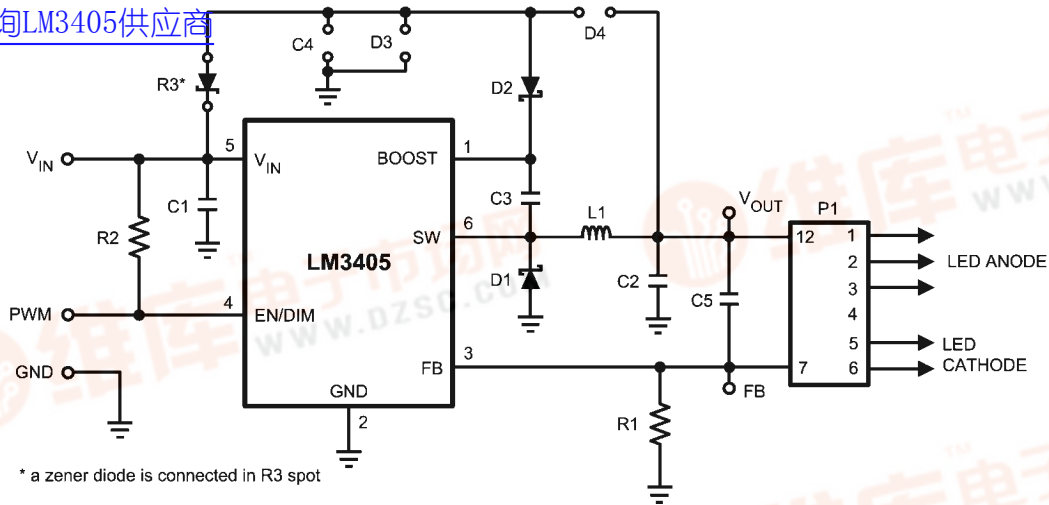

$V_{BOOST}$  Derived from  $V_{IN}$  through a Series Zener Diode

30010016

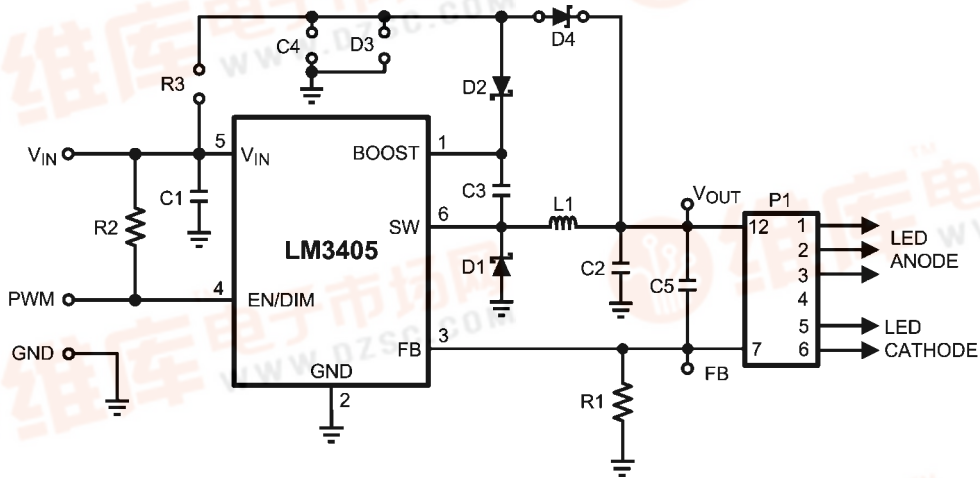

$V_{BOOST}$  Derived from  $V_{OUT}$  through a Series Zener Diode

30010017

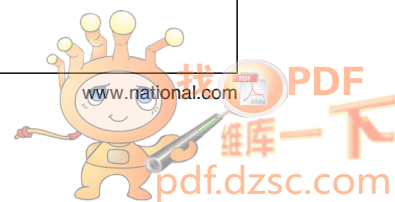

## Notes

THE CONTENTS OF THIS DOCUMENT ARE PROVIDED IN CONNECTION WITH NATIONAL SEMICONDUCTOR CORPORATION ("NATIONAL") PRODUCTS. NATIONAL MAKES NO REPRESENTATIONS OR WARRANTIES WITH RESPECT TO THE ACCURACY OR COMPLETENESS OF THE CONTENTS OF THIS PUBLICATION AND RESERVES THE RIGHT TO MAKE CHANGES TO SPECIFICATIONS AND PRODUCT DESCRIPTIONS AT ANY TIME WITHOUT NOTICE. NO LICENSE, WHETHER EXPRESS, IMPLIED, ARISING BY ESTOPPEL OR OTHERWISE, TO ANY INTELLECTUAL PROPERTY RIGHTS IS GRANTED BY THIS DOCUMENT.

TESTING AND OTHER QUALITY CONTROLS ARE USED TO THE EXTENT NATIONAL DEEMS NECESSARY TO SUPPORT NATIONAL'S PRODUCT WARRANTY. EXCEPT WHERE MANDATED BY GOVERNMENT REQUIREMENTS, TESTING OF ALL PARAMETERS OF EACH PRODUCT IS NOT NECESSARILY PERFORMED. NATIONAL ASSUMES NO LIABILITY FOR APPLICATIONS ASSISTANCE OR BUYER PRODUCT DESIGN. BUYERS ARE RESPONSIBLE FOR THEIR PRODUCTS AND APPLICATIONS USING NATIONAL COMPONENTS. PRIOR TO USING OR DISTRIBUTING ANY PRODUCTS THAT INCLUDE NATIONAL COMPONENTS, BUYERS SHOULD PROVIDE ADEQUATE DESIGN, TESTING AND OPERATING SAFEGUARDS.

EXCEPT AS PROVIDED IN NATIONAL'S TERMS AND CONDITIONS OF SALE FOR SUCH PRODUCTS, NATIONAL ASSUMES NO LIABILITY WHATSOEVER, AND NATIONAL DISCLAIMS ANY EXPRESS OR IMPLIED WARRANTY RELATING TO THE SALE AND/OR USE OF NATIONAL PRODUCTS INCLUDING LIABILITY OR WARRANTIES RELATING TO FITNESS FOR A PARTICULAR PURPOSE, MERCHANTABILITY, OR INFRINGEMENT OF ANY PATENT, COPYRIGHT OR OTHER INTELLECTUAL PROPERTY RIGHT.

**LIFE SUPPORT POLICY**

**NATIONAL'S PRODUCTS ARE NOT AUTHORIZED FOR USE AS CRITICAL COMPONENTS IN LIFE SUPPORT DEVICES OR SYSTEMS WITHOUT THE EXPRESS PRIOR WRITTEN APPROVAL OF THE CHIEF EXECUTIVE OFFICER AND GENERAL COUNSEL OF NATIONAL SEMICONDUCTOR CORPORATION.** As used herein:

Life support devices or systems are devices which (a) are intended for surgical implant into the body, or (b) support or sustain life and whose failure to perform when properly used in accordance with instructions for use provided in the labeling can be reasonably expected to result in a significant injury to the user. A critical component is any component in a life support device or system whose failure to perform can be reasonably expected to cause the failure of the life support device or system or to affect its safety or effectiveness.

National Semiconductor and the National Semiconductor logo are registered trademarks of National Semiconductor Corporation. All other brand or product names may be trademarks or registered trademarks of their respective holders.

Copyright© 2007 National Semiconductor Corporation

For the most current product information visit us at [www.national.com](http://www.national.com)



**National Semiconductor  
Americas Customer  
Support Center**  
Email:  
[new.feedback@nsc.com](mailto:new.feedback@nsc.com)  
Tel: 1-800-272-9959

**National Semiconductor Europe  
Customer Support Center**  
Fax: +49 (0) 180-530-85-86  
Email: [europe.support@nsc.com](mailto:europe.support@nsc.com)  
Deutsch Tel: +49 (0) 69 9508 6208  
English Tel: +49 (0) 870 24 0 2171  
Français Tel: +33 (0) 1 41 91 8790

**National Semiconductor Asia  
Pacific Customer Support Center**  
Email: [ap.support@nsc.com](mailto:ap.support@nsc.com)

**National Semiconductor Japan  
Customer Support Center**  
Fax: 81-3-5639-7507  
Email: [jpn.feedback@nsc.com](mailto:jpn.feedback@nsc.com)  
Tel: 81-3-5639-7560