

LM3423 Buck-Boost Configuration Evaluation Board

National Semiconductor
Application Note 1907
Matthew Reynolds
December 8, 2008



Introduction

This evaluation board has been designed to demonstrate the LM3423 low-side controller as a step-up/step-down (buck-boost) regulator to deliver constant current to high power LEDs. A complete circuit schematic and bill of materials for the evaluation board are included at the end of this document. The printed circuit board consists of two layers of two ounce copper on FR4 material. The LM3423 evaluation board is designed so that all options available can be evaluated and tested. Most applications will only require a few options therefore jumpers can be placed, or removed as needed. A schematic of the full featured LM3423 evaluation board and its bill of materials is provided in this document. Simplified design examples with schematics and a bill of materials follow.

Device Description

The LM3423 is a high voltage, low-side NFET controller with an adjustable output current sense voltage. Output voltage regulation is based on peak current-mode control, which eases the design of loop compensation while providing inherent input voltage feed-forward compensation. The LM3423 includes a high-voltage start-up regulator that operates over a wide input range of 4.5V to 75V. The PWM controller is designed for high speed capability including a switching frequency range to 2.0 MHz. Additional features include "zero" current shutdown, error amplifier, precision reference, logic-compatible DIM input suitable for fast PWM dimming of the output, cycle-by-cycle current limit, LED ready flag, fault flag, programmable fault timer, and thermal shutdown.

Standard Evaluation Board Operating Configuration

- $f_{SW} = 600 \text{ kHz}$
- Over-voltage protection set at 56V
- V_{IN} range 4.5V to 35V
- Low side PWM fast dimming
- 2 to 8 series connected LEDs ($V_O < 35V$)
- UVLO set at 8.4V
- $I_{LED} = 1A$

Available features that can be configured on the standard evaluation board by the user for are listed below:

- Fixed or programmable LED current
- High-speed PWM high-side or low-side dimming
- User programmable over-voltage protection (OVP)
- Under-voltage lock-out (UVLO) protection
- Fault protection
- Soft-start
- Hysteretic current-mode control
- **Higher Input and / or Output Voltage Modifications**
Although the standard LM3423 evaluation board is designed to operate at input and output voltages up to 35V, the device is capable of operating with input and output voltages up to 75V. Operation up to 75V can be achieved by changing the voltage ratings of the input capacitors (C1, C8, C17), output capacitors (C4, C7, C11, C16), and transistors Q4, Q5, Q7. For output voltages greater than 35V the OVP resistors R20 and R22 will need to be adjusted.

Board Connections and Configuration

Connecting the evaluation board to a power supply and load is accomplished through banana-plug type connectors (refer to Table 1).

TABLE 1. LM3423 Eval Board Connectors

Connector Designation	Function or Use
V _{IN}	Power supply (Positive) primary connection
GND	Power supply (Negative) primary connection
LED+	Connect to anode of LED.
LED-	Connect to cathode of LED.

Configuration of the evaluation board is accomplished through the use of on-board jumpers (refer to Table 2).

TABLE 2. LM3423 Evaluation Board Jumpers

Jumper Designation	Function or Use	Notes
J1	Enable (EN)	
	OPEN: Disables LM3423.	
	CLOSED: Enables LM3423.	
J2	Current Limit (IS)	
	OPEN: Disables MOSFET RDS(ON) current sensing "Q5".	
	CLOSED: Enables MOSFET RDS(ON) current sensing "Q5".	
J3	Current Limit (IS)	
	OPEN: Disables external sense resistor MOSFET current sensing "Q5".	
	CLOSED: Enables external sense resistor MOSFET current sensing "Q5".	
J4A, J4B	Current Limit (IS): Must be used in conjunction with jumper J2.	
	OPEN: Enables sensing MOSFET switch current across sense resistor "R6".	
	CLOSED: Disables sensing MOSFET switch current across sense resistor "R6".	
J5	PWM Dimming	
	OPEN: Enables high-side PWM dimming.	
	CLOSED: Disables high-side PWM dimming.	
J6	Fault Timer (FLT)	
	OPEN: External capacitor programs fault condition time to set flag (FLT).	
	CLOSED: Disables fault timer and flag (FLT).	

Test points in the form of clip-on pegs are available to the user for making measurements on the LM3423 evaluation board.

TABLE 3. LM3423 Evaluation Board Test Points

Test Point Designation	Function or Use
TP1	Test point for "LED+" connector (LED anode).
TP2	Test point for "LED-" connector (LED cathode).
TP3	Test point for regulated output voltage.
TP5	Test point for L-RDY pin.
TP6	Test point for "PWM Dimming" input signal.
TP7	Test point for IS pin.
TP8	Test point for nDIM pin.

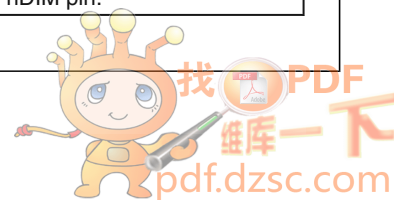

Test Point Designation	Function or Use
TP9	Test point for FLT pin.
TP10	Test point for GROUND.
TP11	Test point for TIMR pin.
TP12	Test point for switch-node.

LM3423 TSSOP Pin Connection

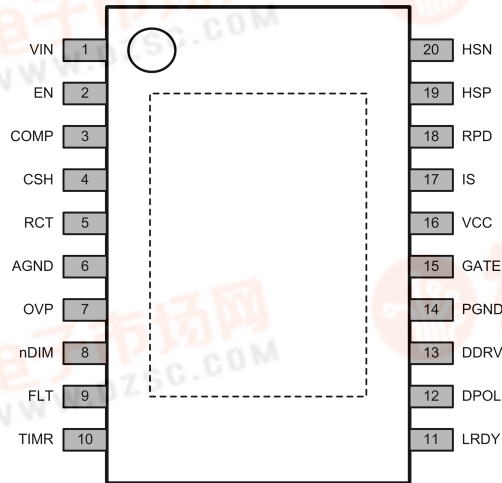

Top View
LM3423 Pin Connection

30080801

Board Features

This evaluation board has all the necessary connections and jumpers to evaluate the LM3423 controller in a boost converter topology with the following operating features and options:

SETTING AVERAGE LED CURRENT

The LM3423 uses peak current-mode control to regulate the boosted output voltage. An external current sense resistor

R_{SENSE} (i.e. R9) in series with the LED load is used to convert the LED current, I_{LED} , into a voltage that is sensed by HSP (pin 19) and HSN (pin 20). HSP and HSN are the inputs to a high side sense amplifier that is used in combination with a resistor tied to CSH (pin 4) and an error amplifier to program a desired I_{LED} current.

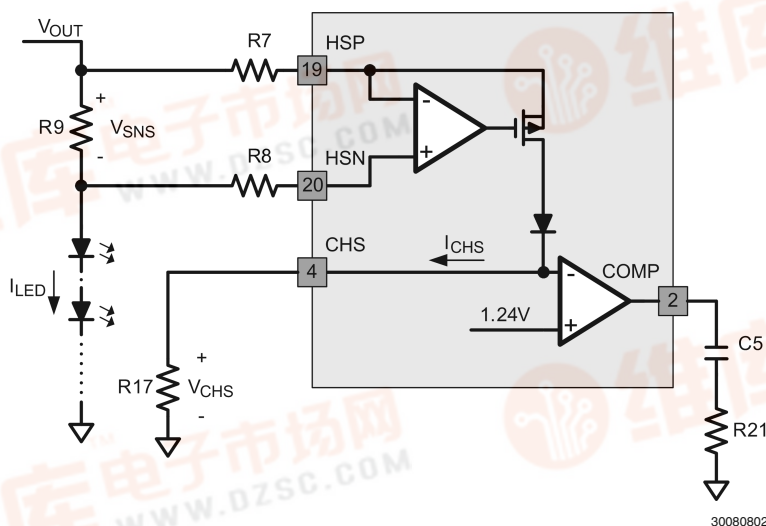

30080802

FIGURE 1. High-Side Sensing Circuit

This establishes a current gain determined by a resistor ratio consisting of R17 and R7 along with R9 as described in the equation:

$$I_{LED} = \left(\frac{R7}{R17} \right) \times \left(\frac{1.24V}{R9} \right)$$

Substituting in the resistor values as listed in the board schematic gives a fixed I_{LED} current of 1A.

SETTING THE CURRENT SENSE VOLTAGE

By substituting in different resistor values, the LED average current can be user adjusted. The LM3423 controller uses a high-side sense amplifier to regulate LED average current. The CSH pin is regulated by the error amplifier to be V_{REF} . Understanding how average LED current is regulated comes down to understanding the relationship between V_{CSH} and V_{SNS} , because V_{SNS} and R_{SNS} set the LED current. The high side amplifier forces its input terminals to equal potential. Because of this, the V_{SNS} voltage is forced across R_{HSP} . Another way to view this is that the amplifier's output transistor pulls current through R7 (R_{HSP}) until $V_{HSP} = V_{HSN}$ and this happens when the voltage across R7 is equal to V_{SNS} .

The current flowing down to the CSH pin is given by,

$$I_{CSH} = \left(\frac{V_{SNS}}{R7} \right)$$

and the voltage at the CSH pin is then given by,

$$V_{CSH} = (R17 \times I_{CSH}) = V_{SNS} \times \left(\frac{R17}{R7} \right)$$

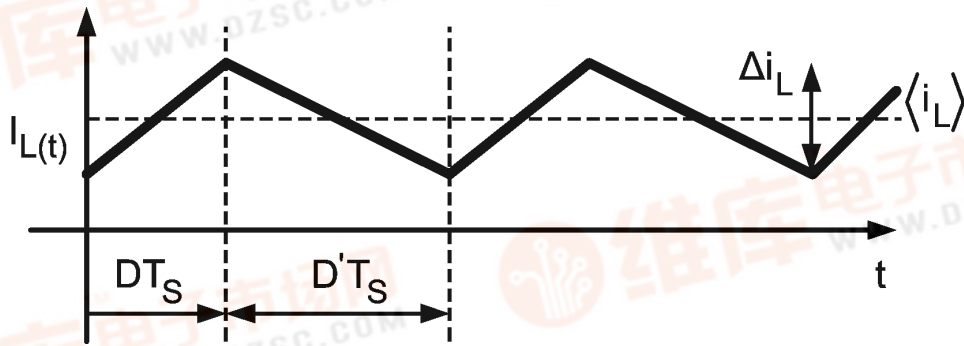

FIGURE 2. Inductor Current Waveform

30080823

The CSH voltage is the sense voltage gained up by the ratio of R17 to R7. In addition, the control system's error amplifier regulates the CSH voltage to V_{REF} . Using equation 14, the following equations are derived,

$$V_{SNS} = V_{REF} \times \left(\frac{R7}{R17} \right)$$

$$I_{LED} = \left(\frac{V_{SNS}}{R9} \right) = \left(\frac{V_{REF}}{R9} \right) \times \left(\frac{R7}{R17} \right)$$

The above equations show how current in the LED relates to the regulated voltage V_{REF} , which is approximately 1.25V for the LM3423.

The selection of resistors is not arbitrary, for matching and noise performance, the CSH current should be set to be around 100 μ A. This current does not flow in the LEDs and will not affect either off state LED current or the regulated LED current. CSH current can be above or below this value, but high side amplifier offset characteristics and jitter performance may be affected slightly.

INDUCTOR SELECTION

The inductor should be chosen so that the current ripple (Δi_L) is between 20% and 40% of the average current ($\langle i_L \rangle$) through the inductor.

The worst case ripple is seen when the input voltage is at its lowest magnitude. This is true if we can say that the output voltage stays relatively constant.

Design Example:

$$V_O \cong 28V$$

$$V_{IN-MIN} = 18V$$

$$V_{IN-NOM} = 24V$$

$$V_{IN-MAX} = 36V$$

$$I_{LED} = 1A$$

Buck Boost Conversion Ratio:

$$\left(\frac{V_O}{V_{IN}}\right) \approx \left(\frac{D}{1-D}\right)$$

Therefore:

$$D \approx \left(\frac{V_O}{V_{IN} + V_O}\right)$$

$$D @ V_{IN-MAX} = 0.436$$

$$D @ V_{IN-MIN} = 0.609$$

$$f_{SW} = \left(\frac{25}{C_1 \times R_1}\right) = 588 \text{ kHz}$$

$$D = \left(\frac{t_{ON}}{t_{ON} + t_{OFF}}\right) = t_{ON} \times f_{SW}$$

$$t_{ON} @ V_{IN-MAX} = 0.742 \mu s$$

$$t_{ON} @ V_{IN-MIN} = 1.05 \mu s$$

Calculate average input current: The average input current is equal to the average inductor current.

$$\left(\frac{P_O}{P_{IN}}\right) = \eta$$

Assume efficiency = 85%

$$\left(\frac{V_O \times I_{LED}}{V_{IN} \times I_{IN}}\right) = 0.85$$

$$I_{IN} = 915 \text{ mA} @ V_{IN} = 36V$$

$$I_{IN} = 1830 \text{ mA} @ V_{IN} = 18V$$

Set inductor current ripple for 30% of average current.

$$\Delta I_{IN} = 915 \text{ mA} \times 0.30 = 275 \text{ mA}$$

$$\Delta I_{IN} = 1830 \text{ mA} \times 0.30 = 550 \text{ mA}$$

$$V_{IN} = L \left(\frac{di}{dt}\right)$$

Therefore:

$$L = V_{IN} \left(\frac{dt}{di}\right) = V_{IN} \left(\frac{D}{\Delta i \times f_{SW}}\right)$$

$$\text{Inductor value} @ V_{IN-MIN} \cong 33 \mu H$$

PEAK CURRENT LIMIT

Due to its peak current-mode control architecture, the LM3423 has inherent cycle-to-cycle current limit control. Inductor current flowing through the low-side power MOSFET (Q5) is sensed as a voltage between IS (pin 17) and PGND (pin 14). This voltage is fed into an internal comparator which establishes the peak current allowed during each switching cycle.

Two methods of switch current sensing are available on the evaluation board. The first is accomplished through the use of an external sense resistor which allows for higher accuracy in sensing the peak current. For the LM3423 evaluation board, the sense resistor R6 can be utilized using the jumper configuration as described in Table 4.

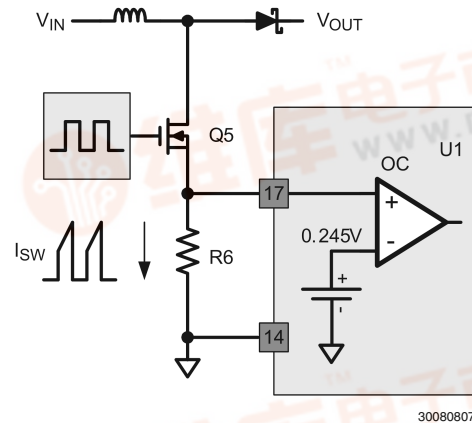

FIGURE 3. External R_{SENSE} I_{SW} Current Sense

TABLE 4. External R_{SENSE} Resistor Configuration

Jumper	Operation
J2	Open Jumper
J3	Close Jumper
J4A, J4B	Open Jumper
R6	Populate

The current limit (I_{CL}) is calculated by the equation:

$$I_{CL} = \left(\frac{0.245V}{R6}\right)$$

Substituting in the resistor value as listed in the board schematic gives a current limit I_{CL} of approximately 4.1A.

MOSFET switch current can also be sensed directly across the $R_{DS(ON)}$ of MOSFET Q5, eliminating the need for a sense resistor (see Table 5).

查询LM3423供应商

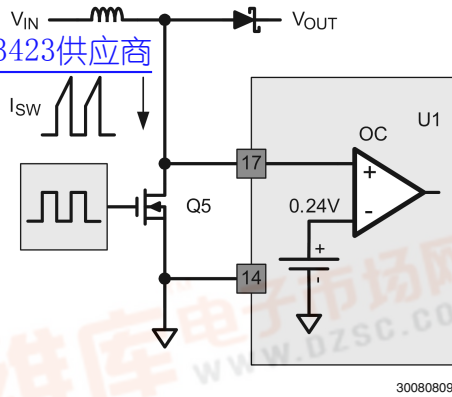

FIGURE 4. MOSFET $R_{DS(ON)}$ Sensing Configuration

TABLE 5. MOSFET $R_{DS(ON)}$ Sensing Configuration

Jumper	Operation
J2	Close Jumper
J3	Open Jumper
J4A, J4B	Close Jumper
R6	No Load

The trade-off will be less accuracy and performance flexibility for reduced component count, and increased efficiency. The current limit (I_{CL}) using this sense method is calculated by the equation:

$$I_{CL} = \left(\frac{0.245V}{R_{DS(ON)}} \right)$$

Substituting in the resistor values as listed in the board schematic and an $R_{DS(ON)}$ of 0.025Ω for Q5 (SUD40N10-25) gives a current limit I_{CL} of approximately 10A.

PWM DIMMING

The average LED forward current is often controlled or reduced with a pulse-width modulated (PWM) signal. By reducing the average LED current, light from the LEDs is reduced. This dimming method allows the converter to operate the LEDs at a specific peak output current level (i_L), which is usually a set point determined by the LED manufacturer. This allows the LED to illuminate with a consistent light color while still having the ability to reduce its lumens output.

The dimming frequency should be fast enough so that the ON and OFF blinking of the LEDs is not perceived by the human eye. Usually the dimming frequency should be greater than 120 Hz, but less than 5 kHz for best results.

The LM3423 evaluation board implements PWM dimming by placing a series connected MOSFET in series with the LED stack. The PWM signal is applied to this MOSFET, and the LED current is interrupted when the MOSFET turns OFF.

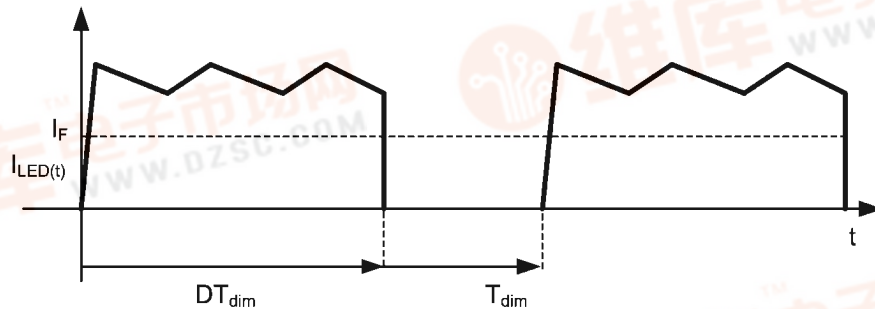

Illustration of Current through LED Stack with PWM Dimming

The LM3423 evaluation board can be configured for either high-side PWM dimming or low-side PWM dimming. The definition of high side dimming is when a MOSFET that interrupts the forward current through the LED stack is placed on the anode side of the LED stack. Low side dimming places the MOSFET on the cathode side of the LED stack. The PWM dimming signal should be applied to either the BNC connector or test point TP6.

Dimming on the low-side (cathode) of the LED load is enabled using the jumper configuration described in Table 6.

TABLE 6. Low-Side PWM Dimming Configuration

Jumper	Operation
J5	Open Jumper

SHUTDOWN OPERATION

The LM3423 can be configured for either a very low quiescent current shut down ("Zero Current" $I_Q < 1 \mu A$), or the standard enable/disable configuration ($I_Q < 3 \text{ mA}$).

"Zero Current" is achieved by tying the bottom resistor of all external resistor dividers (i.e. V_{IN} UVLO, OVP) to the RPD Pin 18. Bias currents in the resistor dividers are essentially eliminated during shutdown. The evaluation board is designed using the "zero" shutdown feature.

FAULT PROTECTION FLAG

The LM3423 can be configured with fault protection by using the fault flag indicator FLT (pin 9).

When a fault condition is detected, the FLT pin will go high (pulled up to V_{IN} by resistor R2).



COMPENSATION

The LM3423 is an error amplifier (EA) which allows for easy single-pin compensation. When a capacitor is used on the output of the converter to reduce LED ripple current, a two pole system results. To offset one of the two poles, and guarantee loop stability, a zero is introduced at the output of the EA. This takes the form of a resistor in series with a compensation capacitor (R21 and C5). The value of the EA resistor and capacitor is calculated to give the same RC time constant as the output capacitor and the dynamic resistance (RD) of the LED string.

$$(r_{D-TOTAL} \times C_{OUT}) = (R21 \times C5)$$

LED DYNAMIC RESISTANCE

When the load is an LED or string of LEDs, the load resistance is replaced with the dynamic resistance (r_D) and the current sense resistor. LEDs are PN junction diodes, and their dynamic resistance shifts as their forward current changes. Dividing V_F by I_F leads to incorrect results that are 5 to 10 times higher than the true r_D value.

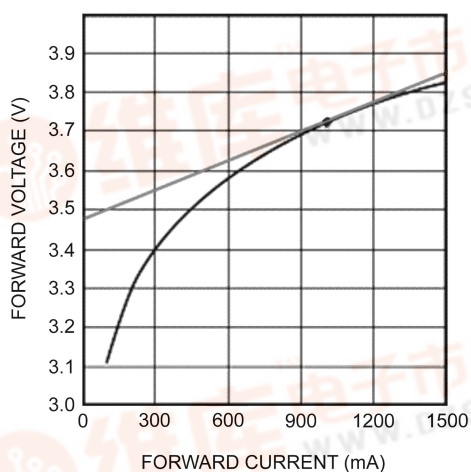

FIGURE 5. Dynamic Resistance

1 Amp is a typical driving current for 3W LEDs, and the calculation below shows how the dynamic resistance of a 5W white InGaN was determined at 1A:

$$\Delta V_F = 3.85V - 3.48V = 370 \text{ mV}$$

$$\Delta I_F = 1.5A - 0A = 1.5A$$

$$r_D = \Delta V_F / \Delta I_F = 370 \text{ mV} / 1.5A = 250 \text{ m}\Omega$$

Dynamic resistances combine in series and parallel like linear resistors, hence for a string of 'n' series-connected LEDs the total dynamic resistance would be:

$$r_{D-TOTAL} = n \times r_D + R_{SNS} = 5(250 \text{ m}\Omega) + 100 \text{ m}\Omega = 1.35\Omega$$

Now that we have calculated the dynamic resistance of our LED string, we can calculate the compensation resistor and capacitor values (C5 and R21).

$$C_{OUT} = 330 \mu\text{F} \text{ and } r_D = 1.35\Omega$$

$$r_{D-TOTAL} \times C_{OUT} = 1.95\Omega \times 220 \mu\text{F} = 430E-6$$

Choose C5 to equal 100 nF, therefore R21 equals 4.32 k Ω

OVERVOLTAGE PROTECTION

An over-voltage protection (OVP) with programmable hysteresis feature is available on the LM3423 to protect the device from damage when the boosted output voltage goes above a maximum value.

The OVP threshold is set up by the resistor divider network of R22 and R20 which is referenced to the regulated output voltage (V_O). The OVP threshold and hysteresis can be programmed completely independent of each other. OVP hysteresis is accomplished with an internal 23 μA current source that is switched on and off into the impedance of the OVP set-point resistor divider. When the OVP pin exceeds 1.24V, the current source is activated to instantly raise the voltage at the OVP pin. When the OVP pin voltage falls below the 1.24V threshold, the current source is turned off, causing the voltage at the OVP pin to fall.

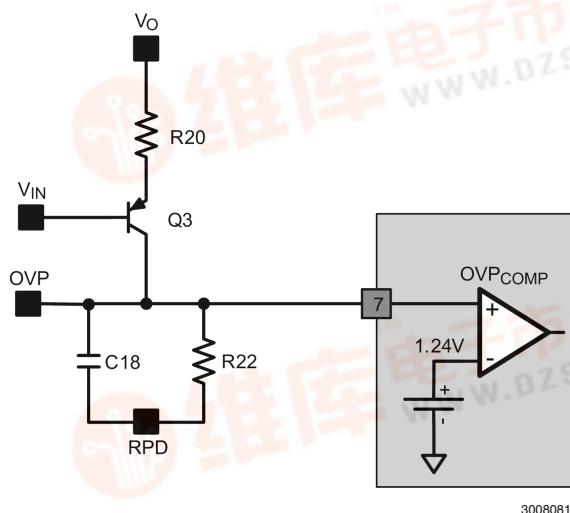

FIGURE 6. OVP Circuit

Calculating OVP hysteresis and set points:

Step 1: Determine V_{HYST} , $V_{HYST} = (V_{OVP_UP} - V_{OVP_DN})$

Step 2: Calculate R20

$$R20 = \frac{V_{HYST}}{23 \mu\text{A}}$$

The V_O OVP release point (which includes the OVP hysteresis) is described by the equation:

$$R22 = \left(\frac{R20 \times 1.24V}{V_{OVP_UP} - 1.24V} \right)$$

The evaluation board is already configured with OVP, and the V_O OVP threshold is programmed on the evaluation board to 55V with 13V of hysteresis. OVP will therefore release when V_O reaches 42V ($R20 = 562 \text{ k}\Omega$, $R22 = 12.4 \text{ k}\Omega$).

UNDER-VOLTAGE PROTECTION

The LM3423 can be configured for under-voltage lockout (UVLO) protection with hysteresis using the dimming input nDIM (pin 8) and a resistor divider from input voltage to ground. UVLO protects the power devices during power supply startup and shutdown to prevent operation at voltages less than the minimum operating input voltage. The UVLO threshold is set up by the resistor divider network of R13 and R25 (see figure below).

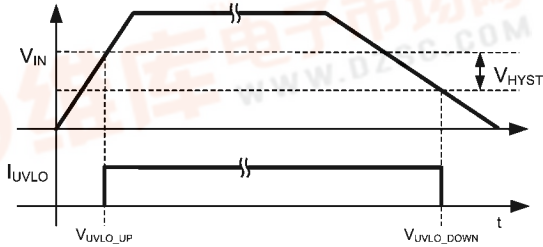

30080815

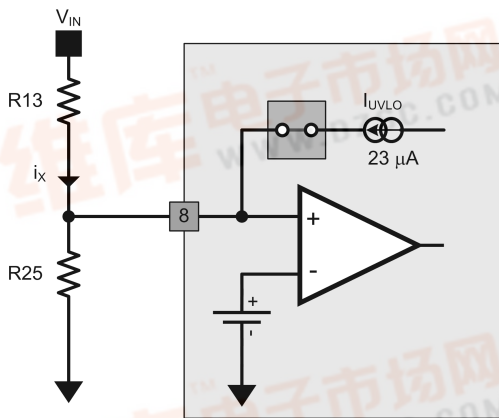

30080816

FIGURE 7. UVLO Circuit During Start-Up

The UVLO threshold and hysteresis can be programmed completely independent of each other. UVLO hysteresis is accomplished with an internal 23 μA current source that is switched on and off into the impedance of the UVLO set-point resistor divider. When the UVLO pin exceeds 1.24V, the current source is activated to instantly raise the voltage at the UVLO pin. When the UVLO pin voltage falls below the 1.24V threshold, the current source is turned off, causing the voltage at the UVLO pin to fall. The UVLO hysteresis range can be user adjusted using the gain resistor R26.

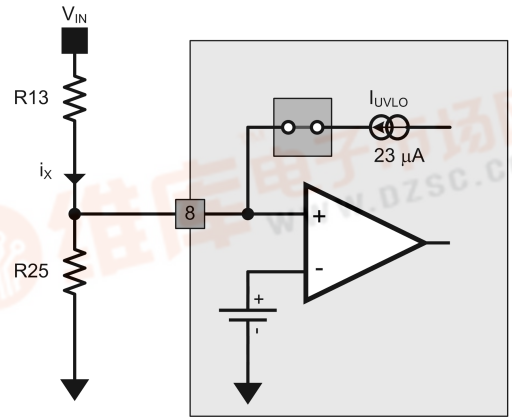

30080816

FIGURE 8. UVLO Circuit During Normal Operation

Step 1: Choose V_{IN} voltage where converter starts to operate (V_{UV_UP}) and choose V_{IN} voltage where converter shuts down (V_{UV_DN}). $V_{HYST} = (V_{UVLO_UP} - V_{UV_DN})$

Step 2: Solve for resistor value R13 with the following equation.

$$R13 = \frac{V_{HYST}}{23 \mu\text{A}}$$

Solve for resistor value R25 with the following equation:

$$R25 = \left(\frac{R13 \times 1.24\text{V}}{V_{IN_UP} - 1.24\text{V}} \right)$$

Example Calculation of UVLO with Hysteresis:

- V_{IN} start-up = $V_{UV_UP} = 8.45\text{V}$
- V_{IN} shut down = $V_{UV_DN} = 8.2\text{V}$
- $I_{UVLO} = 23 \mu\text{A}$
- $V_{HYST} = 8.45\text{V} - 8.2 = 0.25\text{V}$
- $R13 \approx 10 \text{ k}\Omega$
- $R25 \approx 1.74 \text{ k}\Omega$

If a small amount of hysteresis is desired and V_{IN} is large, resistor R26 may need to be populated.

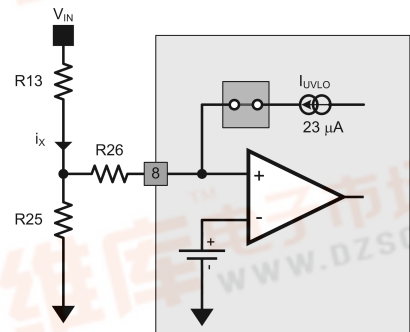

30080820

FIGURE 9. UVLO Circuit with R26 Populated for Small Hysteresis and Large Input Voltage

Evaluation Board Test Procedure

PROPER BOARD CONNECTIONS

Be sure to choose the correct wire size when connecting the source supply and load. Monitor the current into and out of the unit under test (UUT). Monitor the voltages directly at the board terminals, as resistive voltage drops along the wires may decrease measurement accuracy. The LM3423 evaluation board has two pairs of positive and negative inputs connectors which allows for Kelvin connections to be made from the power supplies to the evaluation board. These precautions are especially important during measurement of conversion efficiency.

LM3423 Evaluation Board Schematic

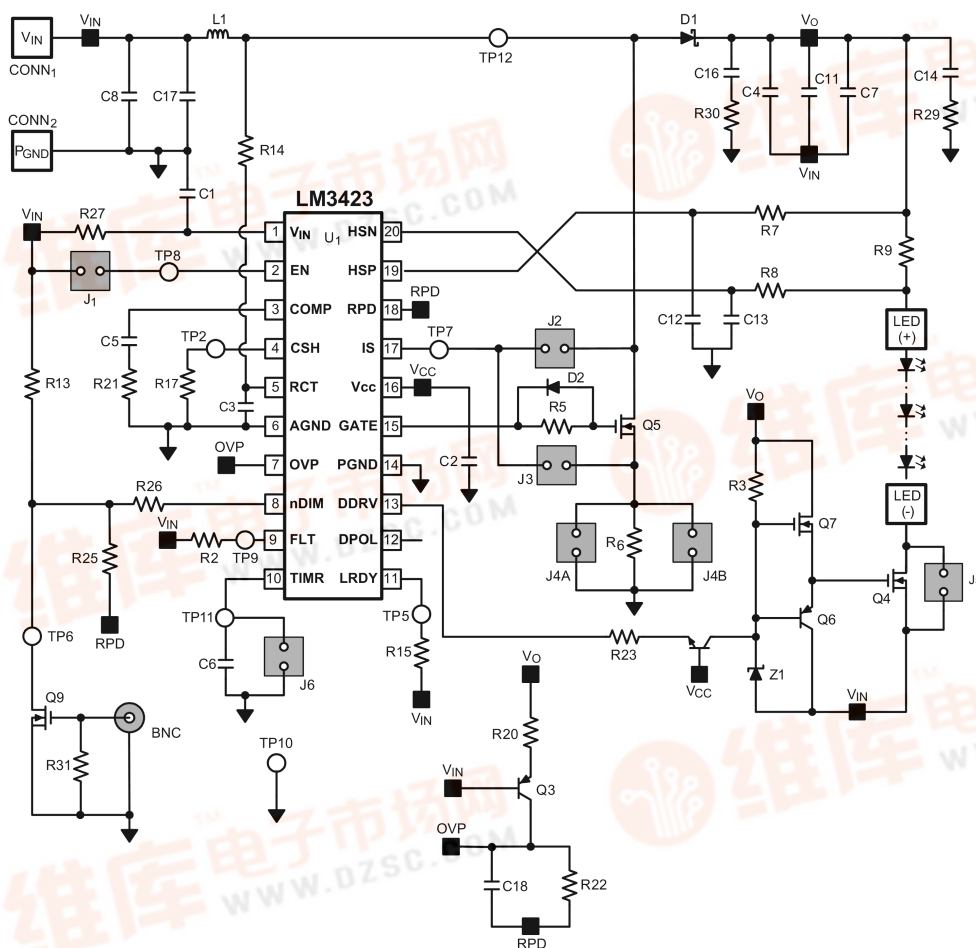

LM3423 Evaluation Board: All features and external components shown

30080821

Bill of Materials

[查询LM3423供应商](#)

Part ID	Part Value	Manufacturer	Part Number
U1	Buck-Boost controller, TSSOP20	NSC	LM3423MH
C1	0.1 μ F 10% 25V	Vishay	VJ0805Y104KXXCW1BC
C2	2.2 μ F, 25V	Panasonic	ECJ-2FB1E225K
C3	Capacitor 0805 1200 pF, 100V	Murata	GRM2195C2A122JA01D
C4, C11	Capacitor 1210 10 μ F, 25V	Panasonic	ECJ-4YB1E106M
C5	Capacitor 0805 0.022 μ F, 50V	Panasonic	ECJ-2VB1H223K
C6	Capacitor 0805 0.01 μ F, 50V	Panasonic	ECJ-2VB1H103K
C7, C8	Capacitor 330 μ F, 35V 5mm Lead	Panasonic	ECA-1VM331
C12, C13, C18	Capacitor 0805 47 pF, 50V	Panasonic	ECJ 2VC1H470J
C14, C16, C17	Capacitor 1206 0.1 μ F, 50V	Murata	GRM319R71H104KA01D
D1	D-Pak 12A, 100V	Vishay	12CWQ10FN
D2	SOT-23 200 mA, 100V	Fairchild	MMBD914L
VIN, GND, LED+, LED-	Connector	Keystone	575-8
J1-J6	Jumper	Molex	22-28-4023
L1	22 μ H	Coilcraft	DO5040H
Q1, Q5	N-channel MOSFET TO-252 40A, 100V	Vishay	SUD40N10-25-E3
Q3	SOT-23 200mA, 40V	Fairchild	MMB3904
Q6	SOT-23 200mA, 40V	Fairchild	MMB2907
Q7, Q9	N channel MOSFET SOT23 200mA, 60V	Fairchild	2N7002
R2, R3, R15	Resistor 0805 100 k Ω	Vishay	CRCW08051003F
R5	0 Ω		
R6	Resistor 2512 0.06 Ω	Vishay	WSL2512R0600FEA
R7, R8	Resistor 0805 1 k Ω	Vishay	CRCW08051001F
R9	Resistor 1812 0.1	Panasonic	ERJL12KF10CU
R13, R31, R23	Resistor 0805 10k	Vishay	CRCW08051002F
R14	Resistor 0805 35.7k	Vishay	CRCW08053572F
R17, R22	Resistor 0805 12.4 k Ω	Vishay	CRCW08051242F
R21, R26	Resistor 0805 4.99k	Vishay	CRCW08054991F
R20	Resistor 0805 562 k Ω	Vishay	CRCW08055623F
R25	Resistor 1206 1.74k	Vishay	CRCW12061741F
R27	Resistor 0805 10 Ω	Vishay	CRCW080510R0F
R29, R30	Resistor 1206 2 Ω	Yageo	RC1206JR-072RL
Z1	Zenner diode 10V 225 mW	Vishay	MMBZ5240-V
Test Points	Connector	Keystone	1502-2



LM3421 Buck-Boost Design Example (High Side Current Sense & High Speed Dimming)

[查询LM3423供应商](#)

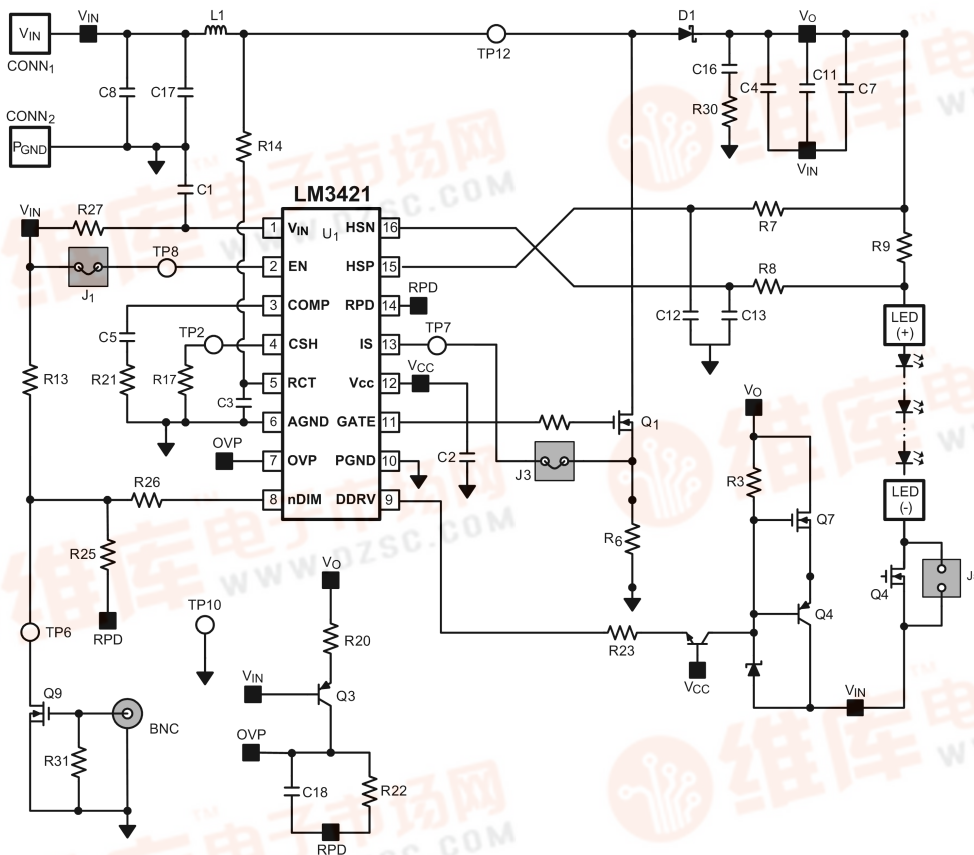

LM3421 Design Example: High Side Current Sense with High Speed Dimming

30080822



LM3421 Buck-Boost Design Example (High Side Current Sense)

[查询LM3423供应商](#)

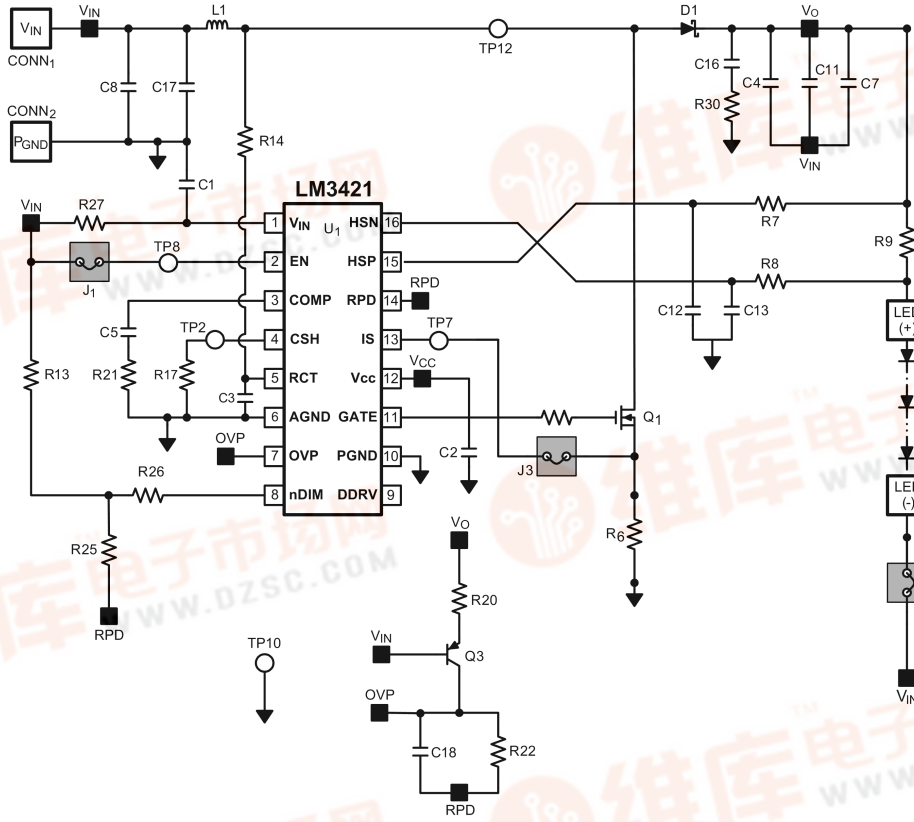

LM3421 Design Example: High Side Current Sense

30080832



[查询LM3423供应商](#)

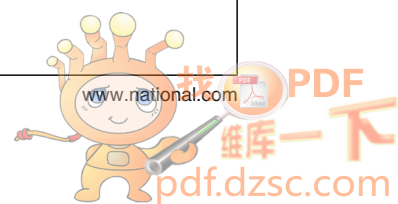

[查询LM3423供应商](#)

Notes

For more National Semiconductor product information and proven design tools, visit the following Web sites at:

Products		Design Support	
Amplifiers	www.national.com/amplifiers	WEBENCH® Tools	www.national.com/webench
Audio	www.national.com/audio	App Notes	www.national.com/appnotes
Clock and Timing	www.national.com/timing	Reference Designs	www.national.com/refdesigns
Data Converters	www.national.com/adc	Samples	www.national.com/samples
Interface	www.national.com/interface	Eval Boards	www.national.com/evalboards
LVDS	www.national.com/lvds	Packaging	www.national.com/packaging
Power Management	www.national.com/power	Green Compliance	www.national.com/quality/green
Switching Regulators	www.national.com/switchers	Distributors	www.national.com/contacts
LDOs	www.national.com/ldo	Quality and Reliability	www.national.com/quality
LED Lighting	www.national.com/led	Feedback/Support	www.national.com/feedback
Voltage Reference	www.national.com/vref	Design Made Easy	www.national.com/easy
PowerWise® Solutions	www.national.com/powerwise	Solutions	www.national.com/solutions
Serial Digital Interface (SDI)	www.national.com/sdi	Mil/Aero	www.national.com/milaero
Temperature Sensors	www.national.com/tempsensors	Solar Magic®	www.national.com/solarmagic
Wireless (PLL/VCO)	www.national.com/wireless	Analog University®	www.national.com/AU

THE CONTENTS OF THIS DOCUMENT ARE PROVIDED IN CONNECTION WITH NATIONAL SEMICONDUCTOR CORPORATION ("NATIONAL") PRODUCTS. NATIONAL MAKES NO REPRESENTATIONS OR WARRANTIES WITH RESPECT TO THE ACCURACY OR COMPLETENESS OF THE CONTENTS OF THIS PUBLICATION AND RESERVES THE RIGHT TO MAKE CHANGES TO SPECIFICATIONS AND PRODUCT DESCRIPTIONS AT ANY TIME WITHOUT NOTICE. NO LICENSE, WHETHER EXPRESS, IMPLIED, ARISING BY ESTOPPEL OR OTHERWISE, TO ANY INTELLECTUAL PROPERTY RIGHTS IS GRANTED BY THIS DOCUMENT.

TESTING AND OTHER QUALITY CONTROLS ARE USED TO THE EXTENT NATIONAL DEEMS NECESSARY TO SUPPORT NATIONAL'S PRODUCT WARRANTY. EXCEPT WHERE MANDATED BY GOVERNMENT REQUIREMENTS, TESTING OF ALL PARAMETERS OF EACH PRODUCT IS NOT NECESSARILY PERFORMED. NATIONAL ASSUMES NO LIABILITY FOR APPLICATIONS ASSISTANCE OR BUYER PRODUCT DESIGN. BUYERS ARE RESPONSIBLE FOR THEIR PRODUCTS AND APPLICATIONS USING NATIONAL COMPONENTS. PRIOR TO USING OR DISTRIBUTING ANY PRODUCTS THAT INCLUDE NATIONAL COMPONENTS, BUYERS SHOULD PROVIDE ADEQUATE DESIGN, TESTING AND OPERATING SAFEGUARDS.

EXCEPT AS PROVIDED IN NATIONAL'S TERMS AND CONDITIONS OF SALE FOR SUCH PRODUCTS, NATIONAL ASSUMES NO LIABILITY WHATSOEVER, AND NATIONAL DISCLAIMS ANY EXPRESS OR IMPLIED WARRANTY RELATING TO THE SALE AND/OR USE OF NATIONAL PRODUCTS INCLUDING LIABILITY OR WARRANTIES RELATING TO FITNESS FOR A PARTICULAR PURPOSE, MERCHANTABILITY, OR INFRINGEMENT OF ANY PATENT, COPYRIGHT OR OTHER INTELLECTUAL PROPERTY RIGHT.

LIFE SUPPORT POLICY

NATIONAL'S PRODUCTS ARE NOT AUTHORIZED FOR USE AS CRITICAL COMPONENTS IN LIFE SUPPORT DEVICES OR SYSTEMS WITHOUT THE EXPRESS PRIOR WRITTEN APPROVAL OF THE CHIEF EXECUTIVE OFFICER AND GENERAL COUNSEL OF NATIONAL SEMICONDUCTOR CORPORATION. As used herein:

Life support devices or systems are devices which (a) are intended for surgical implant into the body, or (b) support or sustain life and whose failure to perform when properly used in accordance with instructions for use provided in the labeling can be reasonably expected to result in a significant injury to the user. A critical component is any component in a life support device or system whose failure to perform can be reasonably expected to cause the failure of the life support device or system or to affect its safety or effectiveness.

National Semiconductor and the National Semiconductor logo are registered trademarks of National Semiconductor Corporation. All other brand or product names may be trademarks or registered trademarks of their respective holders.

Copyright© 2008 National Semiconductor Corporation

For the most current product information visit us at www.national.com



National Semiconductor Americas Technical Support Center
Email: support@nsc.com
Tel: 1-800-272-9959

National Semiconductor Europe Technical Support Center
Email: europe.support@nsc.com
German Tel: +49 (0) 180 5010 771
English Tel: +44 (0) 870 850 4288

National Semiconductor Asia Pacific Technical Support Center
Email: ap.support@nsc.com

National Semiconductor Japan Technical Support Center
Email: jpn.feedback@nsc.com