

LM3528 Evaluation Board

[查询LM3528供应商](#)

National Semiconductor
 Application Note 1823
 Travis Eichhorn
 August 4, 2008



Introduction

The LM3528 is an asynchronous boost converter with two separate outputs. The first output (MAIN) is a constant current source for driving up to 6 series white LED's. The second output (SUB) is configurable as a constant current source for driving up to six series white LEDs, or as a feedback input to set a constant supply voltage for OLED panel power. The maximum LED current per output is set via a single external low power resistor. An I²C compatible interface allows for independent adjustment of the LED current in either output from 0 to max current in 128 exponential steps. When configured

as a white LED + OLED bias supply the LM3528 can independently and simultaneously drive a string of up to six white LED's and deliver a constant output voltage of up to 21V for OLED panels.

The evaluation board is set up to drive two strings of six white LEDs (Nichia , NSSW008C, $V_F = 3.2V$ at 20 mA). These are set up with six LEDs in the MAIN string and six LEDs in the SUB string. Alternatively, resistors can be installed in the R1 and R2 pads to make the device a voltage output boost converter for OLED display powering (see Output Voltage Setting (OLED Mode)).

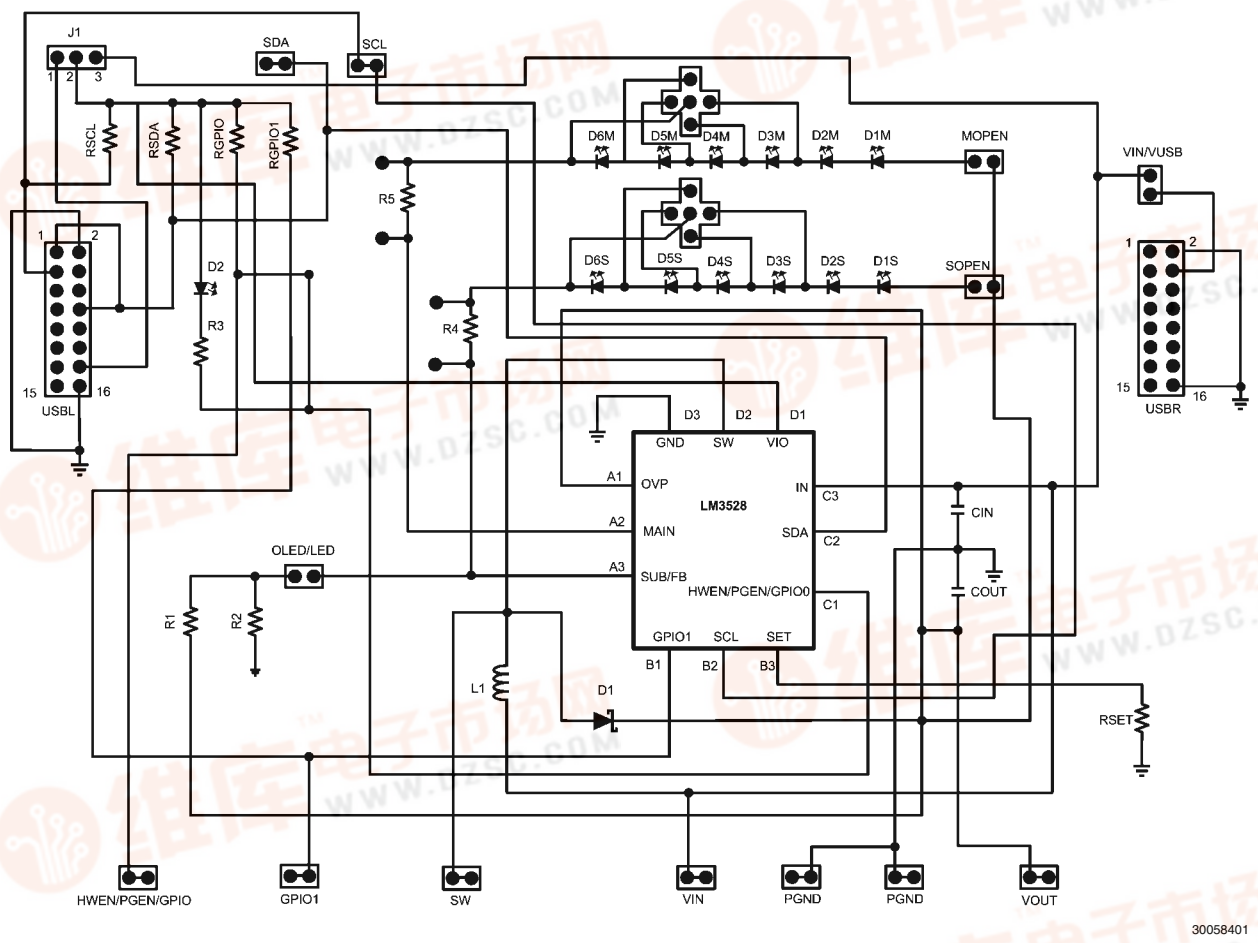

FIGURE 1. LM3528 Evaluation Board Schematic

30058401



LM3528 Evaluation Board Bill of Materials

[查询LM3528供应商](#)

National Semiconductor I.C.	Silicon Revision	Package Mark	Package
LM3528	A1	SE	TMD12AAA

Component Symbol	Value	Mfr.	Part #
L1	10 μ H, $I_{SAT} = 790$ mA	TDK	VLF4012AT-100MR79
CIN	1 μ F, 10V	TDK	C1608JB1A105M
COUT	1 μ F, 25V	TDK	C1608JB1E105M
D1M-D6M	White LED	Nichia	NSSW008C
D1S-D6S	White LED	Nichia	NSSW008C
RSDA	10 k Ω	Vishay	CRCW06031002F
RSCL	10 k Ω	Vishay	CRCW06031002F
RPU	1 M Ω	Vishay	CRCW06031004F
D1	Schottky, 500 mA	Diodes Incorporated	SDM20U30 (SOD-523)
D2	Red LED	Stanley Electric	HKR1105W
R1	Not Installed		
R2	Not Installed		
R3	205 Ω	Vishay	CRCW06032050F
R4	0 Ω	Vishay	CRCW0603
R5	0 Ω	Vishay	CRCW0603
RSET	12.1k Ω	Vishay	CRCW06031212F



LM3528 Evaluation Board Layout

[查询LM3528供应商](#)

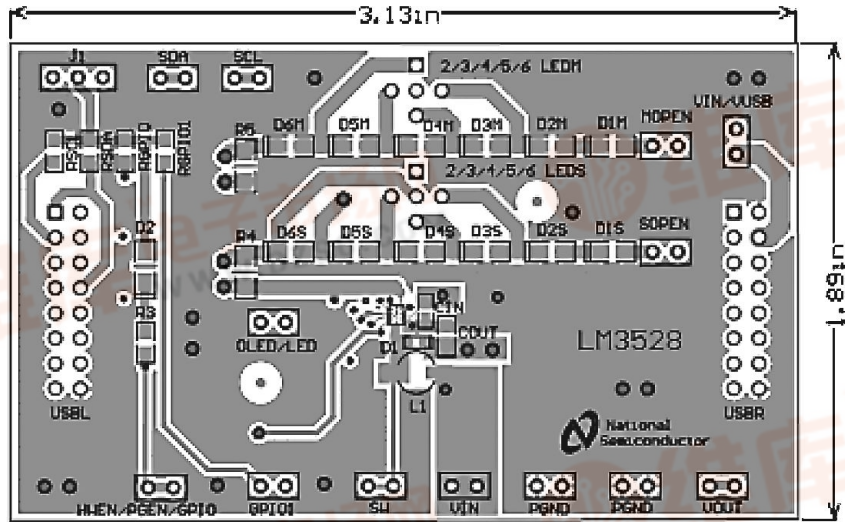

30058404

FIGURE 2. Top View (Board Layout)

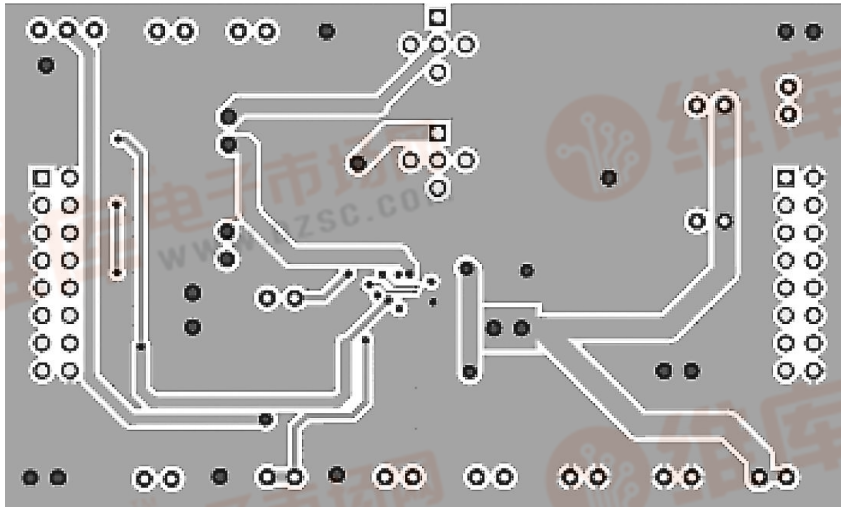

30058405

FIGURE 3. Mid Layer 1 (Board Layout)



[查询LM3528供应商](#)

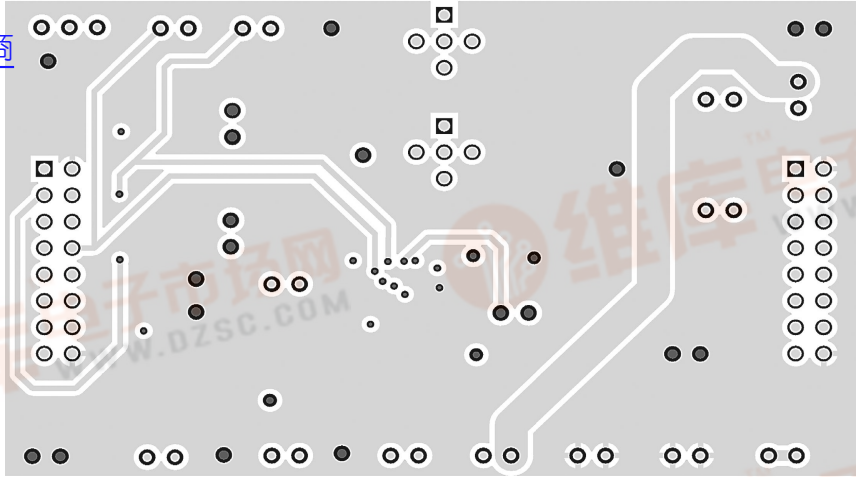

30058406

FIGURE 4. Mid Layer 2(Board Layout)

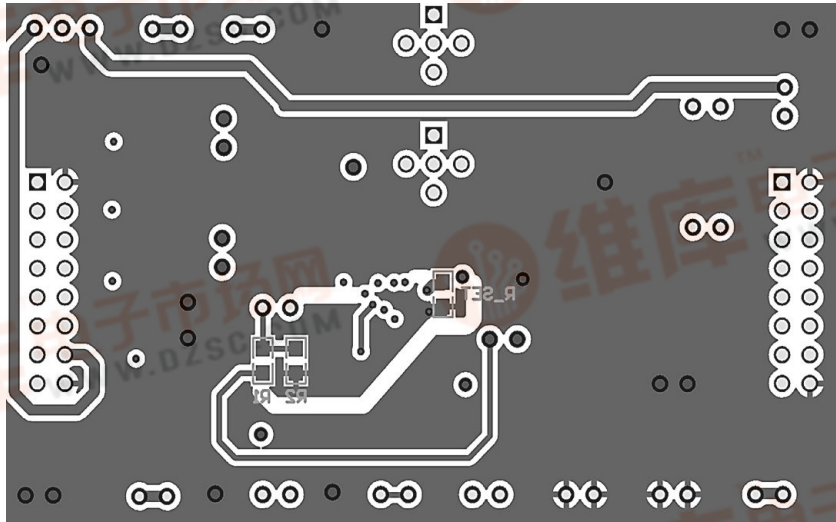

30058407

FIGURE 5. Bottom View (Board Layout)



Board Operation

To operate the LM3528 Evaluation Board, connect a 2.5V to 5.5V supply between the IN header and GND and attach an I²C interface using one of the methods described in the EXTERNAL CONTROL INTERFACE section of this document.

External Control Interface

There are two methods for controlling the LM3528 Evaluation Board. The first option is via a National Semiconductor USB Interface Board. The second option is by using the SDA and SCL headers available on the upper left corner of the board. When option 1 is used, the USBL and USBR connectors plug directly into a National Semiconductor USB Interface Board. The connectors are keyed so they will only fit one way. On the LM3528 Evaluation Board the VIN/VUSB jumper allows for power to come from IN or from the USB. The USB Board can supply 3.3V from an on board regulator or 5V directly from the PC (see documentation for the National Semiconductor USB interface board). When power from the USB is desired connect a jumper across VIN/VUSB, if power is supplied from the IN header leave VIN/VUSB open. DO NOT jumper VIN/VUSB while an external source is connected to IN as this will make a conflict between the USB Board and the external power supply.

The USB interface board interfaces directly with the LM3528.exe graphical interface via the PC (see LM3528 I²C Compatible Interface Program section). If the LM3528.exe program is not used then control of the LM3528 Evaluation Board can be done by connecting an external I²C compatible interface directly to the SCL and SDA headers. Both the SDA and SCL lines have 10 k Ω pull-ups installed on the board.

Basic Connections (Refer to Figure 1)

The LM3528 Evaluation Board is configured for two strings of six LEDs. There are two resistor pads on the bottom side of the board (R1, and R2) which serve as feedback resistors for operation of the LM3528 in voltage output mode (OLED mode). When operating in OLED mode (with D1S – D6S installed) the OLED/LED jumper must be installed in order to connect the center tap of the resistive divider (R1, and R2) to the SUB/FB pin. Additionally, (in OLED mode) the SOPEN header should be removed otherwise the secondary LED string will interfere with the feedback divider and cause erratic operation.

JUMPER CONNECTIONS/COMPONENT DESCRIPTIONS:

- J1 is a 3-pin, 3-position jumper. The left most pin (pin 1 in figure 1) connects to the 3.3V supply from the USB board (pin 14 on the USBL connector). The right most pin (pin 3 in Figure 1) connects to IN. The top middle pin (pin 2 in Figure 1) connects to VIO of the LM3528, the top side of the pull-up resistors (RSDA, RSCL, RGPIO, RGPIO1), and the anode of the indicator diode D2.
- The SOPEN and MOPEN jumpers allow for the disconnection of the LEDs from the LM3528's output. SOPEN opens the SECONDARY (SUB/FB) LED string while MOPEN opens the MAIN LED string. This is useful in testing OVP or disabling a string if OLED mode is required.
- The 5-pin, 5-position jumpers (2/3/4/5/6 LEDM and 2/3/4/5/6 LEDS) located above the MAIN and SECONDARY LED strings respectively, allow for shorting out of different LEDs in both the MAIN and the SECONDARY strings. Both jumpers have their center pin (pin 5 in Figure 1) connected to the cathode of the sixth LED in each string. Referring to jumper 2/3/4/5/6 LEDM, connecting pin 4 to pin 5 will short D6S, thus making the SECONDARY string a five-LED configuration. Connect pin 3 to pin 5 to short D5S and D6S resulting in a four-LED configuration. Connect pin 2 to pin 5 for a three-LED configuration (D4S – D6S shorted). Connect pin 1 to pin 5 for a two-LED configuration (D3S – D6S shorted), and leave jumper 2/3/4/5/6 LEDS open for a six-LED configuration. The operation for jumper 2/3/4/5/6 LEDM is the same only it applies to the MAIN LED string.
- Resistors R4 and R5 have 0 Ω 's across them. The 0 Ω resistors can be replaced with current sense resistors for measuring LED current. Two vias have been placed at the terminals of each resistor which fit standard 0.1" headers.
- The OLED/LED jumper connects or disconnects the resistive divider from the SUB/FB node. In white LED mode the jumper should be open. In OLED mode the jumper should be shorted so the SUB/FB node can regulate VOUT at a constant voltage.
- D2 is a RED indicator diode that flashes the programmed pattern programmed into the PGEN registers (see LM3528 datasheet). R3 is a 205 Ω current limiting resistor for D2. RGPIO is a 1M Ω pull-up resistor for the HWEN/PGEN/GPIO output. On power up, the HWEN/PGEN/GPIO output defaults as an active high hardware enable (HWEN). RGPIO is installed to ensure that HWEN/PGEN/GPIO pulls high on start-up.

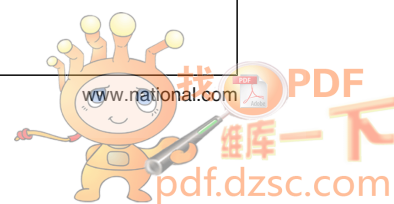

LM3528—USB Interface Board and I²C-Compatible Interface Program

In order to fully evaluate the LM3528, the use of an “I²C Compatible” interface must be used for any functionality to occur. The detailed description regarding the interface control, the LM3528 registers, and OLED mode is described in the LM3528 datasheet.

National has created an I²C-compatible program (see Figure 6) and a USB Interface Board that can help exercise the part in a simple way. The LM3528 evaluation board has the means to “plug into” the USB Interface Board. The USB Interface Board provides all of the control signals for the simple interface and can provide power to the part as well. A jumper on the LM3528 evaluation board labeled VIN/VUSB allows the user to connect either an external power supply to the VIN header on the LM3528 evaluation board, or draw power from the USB board. Removal of the jumper disables the connection of the USB power supply. Once removed, an external supply is required. If the jumper is installed the USB board supplies power to the LM3528 Evaluation board. No adjustments to the USB board are needed. A standard USB cable must be connected to the board from a PC in order to communicate with the LM3528 Evaluation Kit.

For proper operation, the USB Interface board must be plugged into the PC before the LM3528.exe interface program is opened. Once connected, and the program is executed, a basic interface window will open. At the top of the interface, the user can read or write to any of the data registers on the LM3528 using the two pull down menus for the slave I.D. and the desired data address. The data field to the right of the Address pull-down menu accepts hex data while the read and write buttons directly below the Address pull-down menu execute the Read or Write command.

Just below the Read and Write buttons are five enable buttons. Two dedicated enable bits (ENM and ENS) will enable the two LED strings (MAIN and SUB). A dedicated bit (UNI) enables the Unison Mode of the two LED banks, and another bit (OLED) puts the part in OLED mode. The Enable All button simultaneously enables both ENS and ENM.

Below the enable buttons are two sliding bars and data fields that allow all 128 levels of brightness for the MAIN and SUB

banks. Just below the two brightness level slider bars are six convenient action buttons: three set buttons and three reset buttons.

SetM sets the MAIN brightness level to full-scale and enables the MAIN bank.

ResetM resets the MAIN brightness level to zero and disables the MAIN bank.

SetS sets the SUB brightness level to full-scale and enables the SUB bank.

ResetS resets the SUB brightness level to zero and disables the SUB bank.

Set sets the MAIN and the SUB brightness levels to full scale and enables the MAIN and SUB banks.

Reset resets the MAIN and SUB brightness levels to zero and disables the MAIN and SUB banks.

To the right of the 2 brightness level slider bars is a pull-down menu which controls the ramp rate of the brightness level. To the left of the 2 brightness level slider bars are convenient controls for the GPIO1 pin and the HWEN/PGEN/GPIO pin.

The HWEN/PGEN/GPIO pin has three functions: an active high hardware enable (HWEN), a pattern generator output (PGEN), and a general purpose I/O (GPIO). At the bottom of the user interface are button controls for creating the output pattern when HWEN/PGEN/GPIO is in PGEN mode. (see the LM3528 datasheet for a detailed explanation of the pattern generator). The output pattern is determined by the concatenation of four 8-bit data registers: x90, x91, x92 and x93. Each bit for each of these data registers can be set in the user interface (Byte 0 – Byte 3). The hex value of the data register is displayed to the right of the data bits in a data field. To the right of the register data fields are convenient buttons to set all the bits to 1’s or reset all the bits to 0’s.

Once the user has selected the desired pattern, the user loads the pattern into the LM3528 by clicking the “Load” button. Once the output pattern has been loaded, the users can then select the bit period and duty cycle of the pattern using the pull-down menus. Finally, the output pattern is executed by clicking the “Run” button.

Note: If the part is enabled to any brightness level and the program is closed, the LM3528 part will remain in the last programmed state.

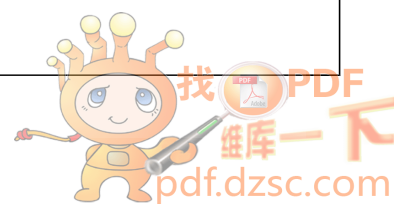

查询LM3528 USB Serial Interface Test App

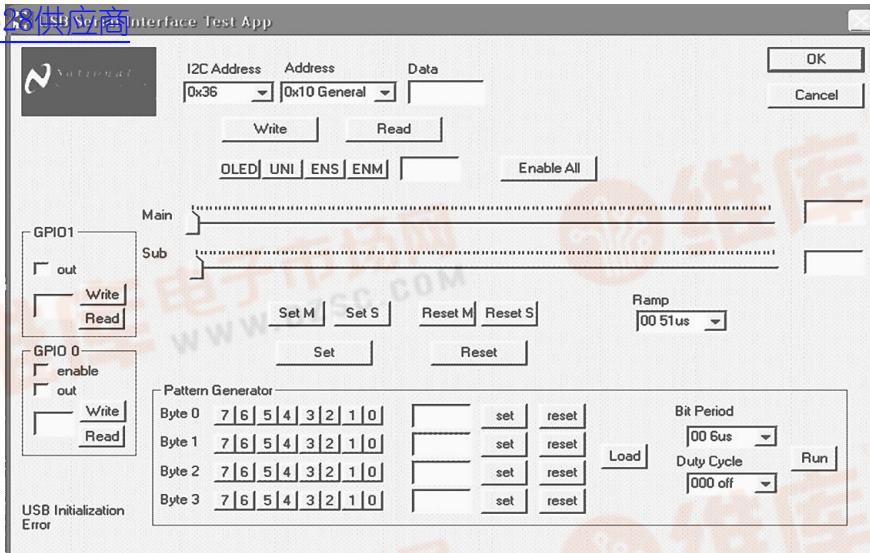
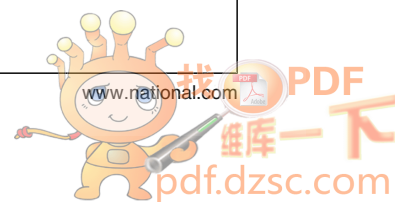

FIGURE 6. LM3528.exe



[查询LM3528供应商](#)

Notes

For more National Semiconductor product information and proven design tools, visit the following Web sites at:

Products		Design Support	
Amplifiers	www.national.com/amplifiers	WEBENCH	www.national.com/webench
Audio	www.national.com/audio	Analog University	www.national.com/AU
Clock Conditioners	www.national.com/timing	App Notes	www.national.com/appnotes
Data Converters	www.national.com/adc	Distributors	www.national.com/contacts
Displays	www.national.com/displays	Green Compliance	www.national.com/quality/green
Ethernet	www.national.com/ethernet	Packaging	www.national.com/packaging
Interface	www.national.com/interface	Quality and Reliability	www.national.com/quality
LVDS	www.national.com/lvds	Reference Designs	www.national.com/refdesigns
Power Management	www.national.com/power	Feedback	www.national.com/feedback
Switching Regulators	www.national.com/switchers		
LDOs	www.national.com/ldo		
LED Lighting	www.national.com/led		
PowerWise	www.national.com/powerwise		
Serial Digital Interface (SDI)	www.national.com/sdi		
Temperature Sensors	www.national.com/tempsensors		
Wireless (PLL/VCO)	www.national.com/wireless		

THE CONTENTS OF THIS DOCUMENT ARE PROVIDED IN CONNECTION WITH NATIONAL SEMICONDUCTOR CORPORATION ("NATIONAL") PRODUCTS. NATIONAL MAKES NO REPRESENTATIONS OR WARRANTIES WITH RESPECT TO THE ACCURACY OR COMPLETENESS OF THE CONTENTS OF THIS PUBLICATION AND RESERVES THE RIGHT TO MAKE CHANGES TO SPECIFICATIONS AND PRODUCT DESCRIPTIONS AT ANY TIME WITHOUT NOTICE. NO LICENSE, WHETHER EXPRESS, IMPLIED, ARISING BY ESTOPPEL OR OTHERWISE, TO ANY INTELLECTUAL PROPERTY RIGHTS IS GRANTED BY THIS DOCUMENT.

TESTING AND OTHER QUALITY CONTROLS ARE USED TO THE EXTENT NATIONAL DEEMS NECESSARY TO SUPPORT NATIONAL'S PRODUCT WARRANTY. EXCEPT WHERE MANDATED BY GOVERNMENT REQUIREMENTS, TESTING OF ALL PARAMETERS OF EACH PRODUCT IS NOT NECESSARILY PERFORMED. NATIONAL ASSUMES NO LIABILITY FOR APPLICATIONS ASSISTANCE OR BUYER PRODUCT DESIGN. BUYERS ARE RESPONSIBLE FOR THEIR PRODUCTS AND APPLICATIONS USING NATIONAL COMPONENTS. PRIOR TO USING OR DISTRIBUTING ANY PRODUCTS THAT INCLUDE NATIONAL COMPONENTS, BUYERS SHOULD PROVIDE ADEQUATE DESIGN, TESTING AND OPERATING SAFEGUARDS.

EXCEPT AS PROVIDED IN NATIONAL'S TERMS AND CONDITIONS OF SALE FOR SUCH PRODUCTS, NATIONAL ASSUMES NO LIABILITY WHATSOEVER, AND NATIONAL DISCLAIMS ANY EXPRESS OR IMPLIED WARRANTY RELATING TO THE SALE AND/OR USE OF NATIONAL PRODUCTS INCLUDING LIABILITY OR WARRANTIES RELATING TO FITNESS FOR A PARTICULAR PURPOSE, MERCHANTABILITY, OR INFRINGEMENT OF ANY PATENT, COPYRIGHT OR OTHER INTELLECTUAL PROPERTY RIGHT.

LIFE SUPPORT POLICY

NATIONAL'S PRODUCTS ARE NOT AUTHORIZED FOR USE AS CRITICAL COMPONENTS IN LIFE SUPPORT DEVICES OR SYSTEMS WITHOUT THE EXPRESS PRIOR WRITTEN APPROVAL OF THE CHIEF EXECUTIVE OFFICER AND GENERAL COUNSEL OF NATIONAL SEMICONDUCTOR CORPORATION. As used herein:

Life support devices or systems are devices which (a) are intended for surgical implant into the body, or (b) support or sustain life and whose failure to perform when properly used in accordance with instructions for use provided in the labeling can be reasonably expected to result in a significant injury to the user. A critical component is any component in a life support device or system whose failure to perform can be reasonably expected to cause the failure of the life support device or system or to affect its safety or effectiveness.

National Semiconductor and the National Semiconductor logo are registered trademarks of National Semiconductor Corporation. All other brand or product names may be trademarks or registered trademarks of their respective holders.

Copyright© 2008 National Semiconductor Corporation

For the most current product information visit us at www.national.com



**National Semiconductor
Americas Technical
Support Center**
Email: support@nsc.com
Tel: 1-800-272-9959

**National Semiconductor Europe
Technical Support Center**
Email: europe.support@nsc.com
German Tel: +49 (0) 180 5010 771
English Tel: +44 (0) 870 850 4288

**National Semiconductor Asia
Pacific Technical Support Center**
Email: ap.support@nsc.com

**National Semiconductor Japan
Technical Support Center**
Email: jpn.feedback@nsc.com