

# LMH6514 Digital Controlled Variable Gain Amplifier Evaluation Board

National Semiconductor  
Application Note 1828  
Loren Siebert  
April 9, 2008



LMH6514 Digital Controlled Variable Gain Amplifier Evaluation Board

## General Description

The LMH6514 evaluation board (part # LMH6514SQEVAL) is designed to aid in the characterization of National Semiconductor's High Speed LMH6514 Digital Controlled Variable Gain Amplifier (DVGA).

Use the evaluation board as a guide for high frequency layout and as a tool to aid in device testing and characterization.

## Basic Operation

The LMH6514 DVGA has differential input and differential output. The LMH6514 will also support single-ended to differential conversion with no transformer required on the input. To aid evaluation with 50Ω single-ended test equipment the LMH6514 evaluation board provides for input and output transformers. For driving the evaluation board from a differential source, symmetrical signal paths are provided. Both input and output paths support fully differential signal paths. For component locations refer to the schematic in *Figure 1*.

The evaluation board uses end mounted SMA connectors. On the IN+ input, resistor R1 provides input termination. The analog supply (VCCA) can be from 4V to 5.25V. The capacitor C5 is a supply bypass capacitor and should be low ESR ceramic. Resistors R11 and R12 as well as capacitor C4 should be left empty.

The LMH6514 evaluation board is designed for transformers with DC isolation between the primary and secondary windings. If baluns (transmission line transformers with no DC blocking) are used make sure to have DC isolation for all transformer pads.

Transformer T1 can provide both impedance matching as well as single ended to differential conversion. The 2:1 transformer matches 50Ω equipment with the 200Ω input impedance of the LMH6514 DVGA and there is an optional capacitor at C3 if additional stability is required. Do not connect the transformer secondary winding directly to ground. The LMH6514 has a self biased input common mode voltage of approximately 1.3V. The amplifier will bias up to the optimal input common mode point. The resistors R2, R24, and R25 are normally left empty. These resistors can be used to force the LMH6514 input common mode to a value different than it's self biased state. Most applications will not require this function.

If using a transmission line transformer for T1, capacitor C1 is necessary to preserve the proper input common mode voltage. For single-ended inputs to the amplifier see *Figure 7* and *Figure 8*

The LMH6514 evaluation board is shipped with a transformer to facilitate testing with single-ended equipment. To drive the

LMH6514 evaluation board with a differential signal transformer T1 must be removed. Then, load capacitor C1 and C16 and cut the trace connecting the capacitor C2. R1 and R5 should be loaded with appropriate valued resistors (normally 50Ω). The C3 capacitor is not needed for this case and the transformer pads should be shorted with a low inductance wire: pad 6 to pad 1 and pad 4 to pad 3.

On the output side of the board is transformer T2. C11 isolates the output common mode voltage from the output transformer primary windings. The output coupling capacitors C13 and C14 are necessary for Balun transformers which provide no DC isolation between the primary and secondary windings, and are also necessary when driving differential loads.

For differential output signals remove transformer T2. Capacitor C11 can be left empty. Do not install resistor R4. Using the transformer T2 pads, place coupling capacitors between pads 3 and 4 and between pads 1 and 6 where the transformer would have been. These should be low ESR ceramic capacitors with a value of 1 nF. These output coupling capacitors are necessary to isolate the output common mode voltage of the LMH6514 from the test equipment. The pads for capacitors C13 and C14 can be used as series output matching resistors. There is no copper between transformer pad #6 and C14. A low impedance short will have to be added manually. Resistors R3 and R4 are normally left empty in this configuration.

The evaluation board supports two gain options. As shipped the evaluation board provides for a low gain, 200Ω output impedance configuration. In order to use the high gain 400Ω configuration, the traces from pins 13 and 16 to VCCA can be cut. See *Figure 6* for a detail of the trace cuts required.

SW1 is used to set the three gain control bits.. When the Latch position of SW1 is in 0 or OFF position, changes in the Gain 2 to Gain 5 bits are processed by the LMH6514 (see paragraph below). When the Latch switch is in 1 or ON position, the last loaded state is held and gain bit switch changes have no affect. Landings for SMA connectors are also provided for high speed triggering of the gain bits.

Since the same pc board is also used for the LMH6515 DVGA the markings on SW1 are not the same as the pin assignments for the LMH6514. On the SW1, Gain\_4 on the board corresponds to Gain\_2 on the LMH6514, Gain\_3 on the board corresponds to Gain\_1 on the LMH6514 and Gain\_2 corresponds to Gain\_0 on the LMH6514.

The LMH6514 evaluation board is a four layer board; all four layers are detailed in *Figure 2* through *Figure 5*.

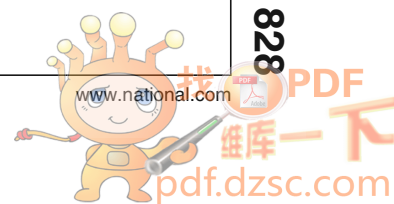

POWER SUPPLY CONNECTIONS

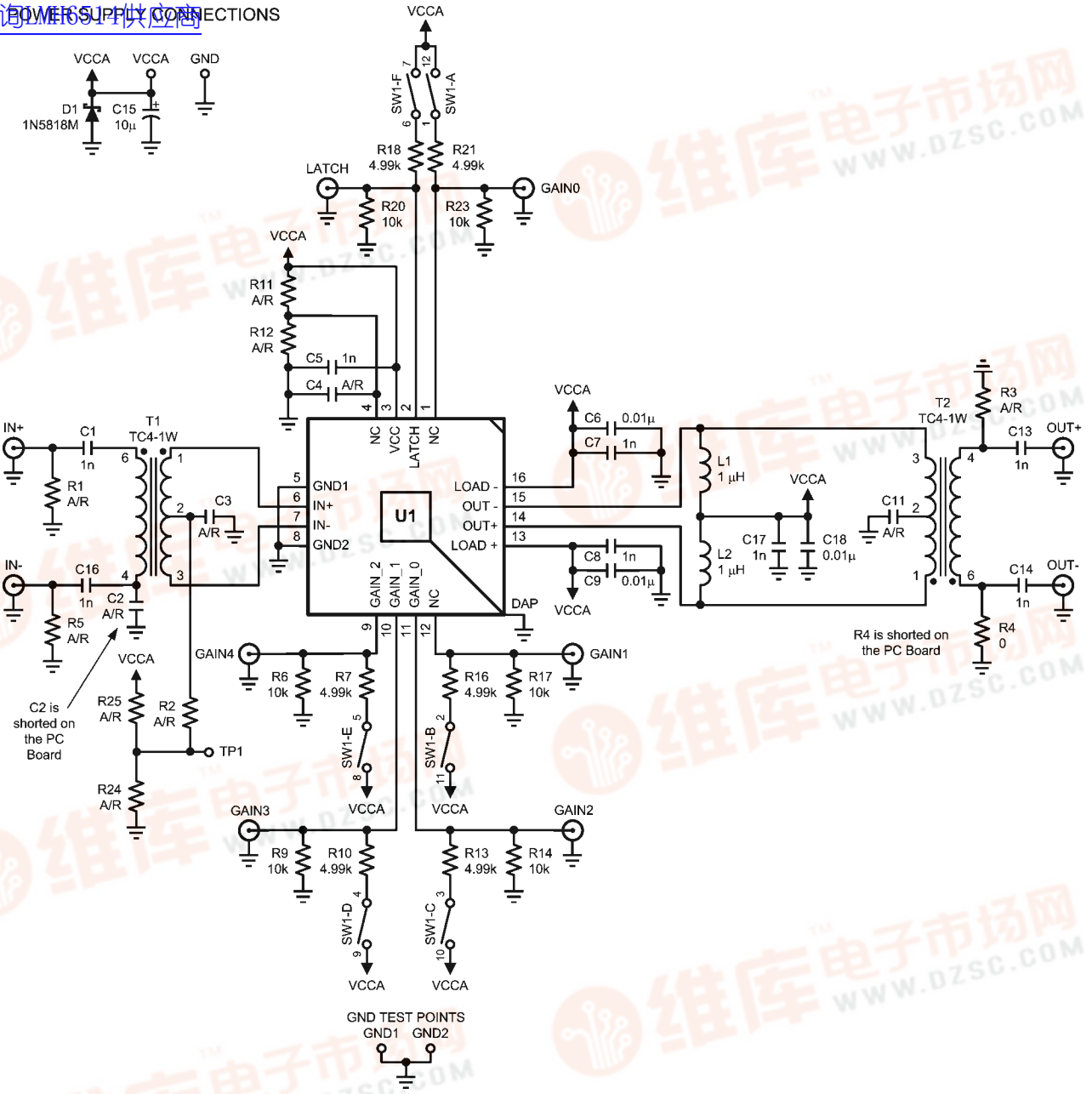
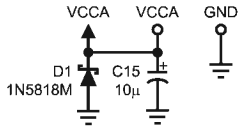
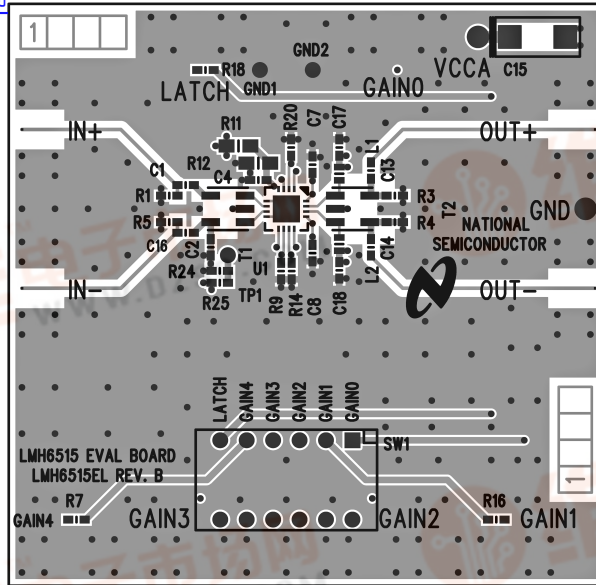

FIGURE 1. LMH6514 Evaluation Board Schematic

30059912



查询LMH6514供应商 NATIONAL SEMICONDUCTOR LAYER1 SILK



30059903

FIGURE 2. Evaluation Board Top Layer

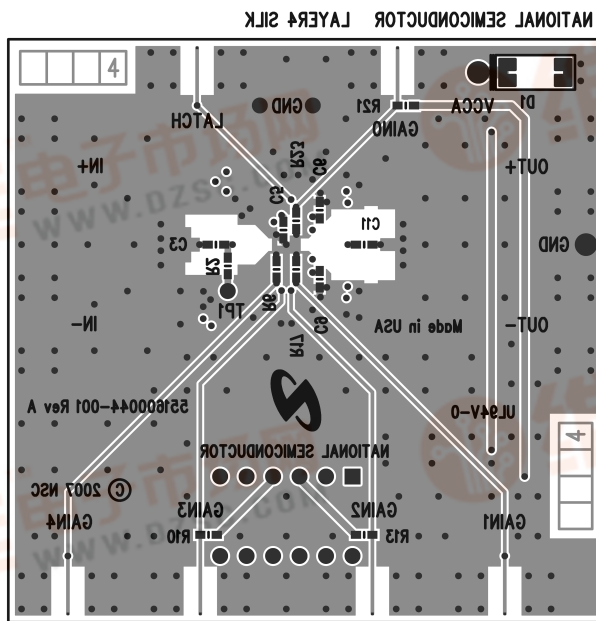

30059904

FIGURE 3. Evaluation Board Bottom Layer



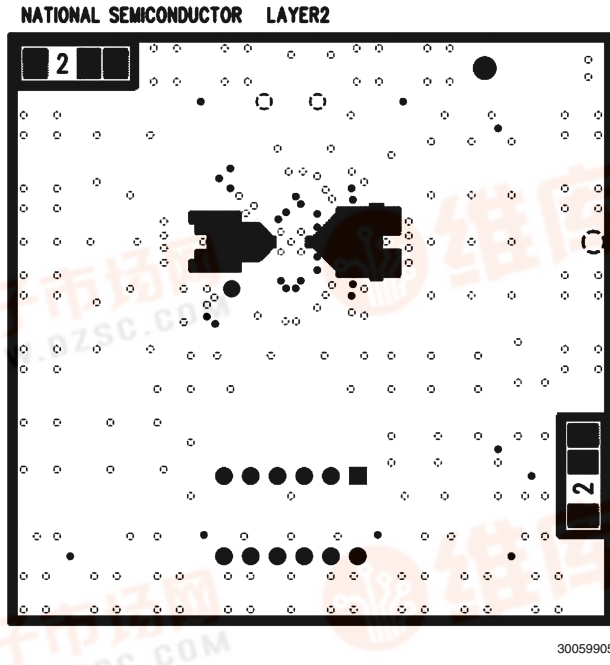

FIGURE 4. Evaluation Board Layer 2

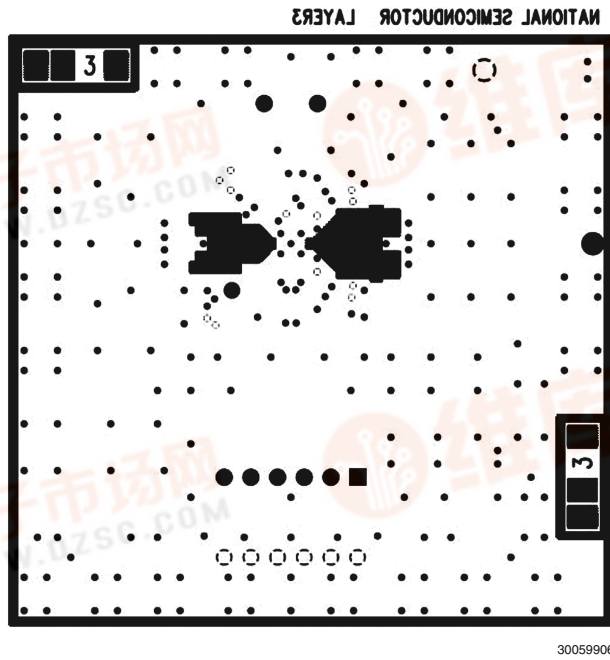
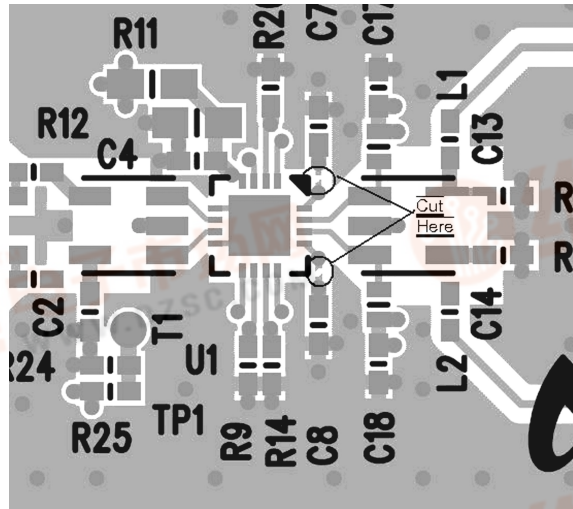

FIGURE 5. Evaluation Board Layer 3



[查询LMH6514供应商](#)



30059907

FIGURE 6. Trace Cuts for High Gain (400Ω Load) Operation

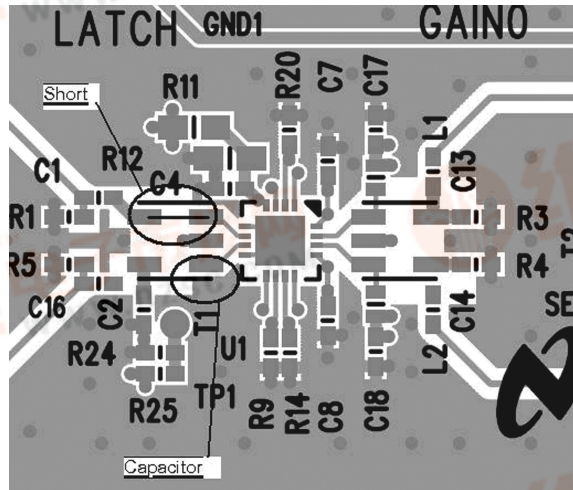

30059908

FIGURE 7. Single- Ended Input — No Transformer

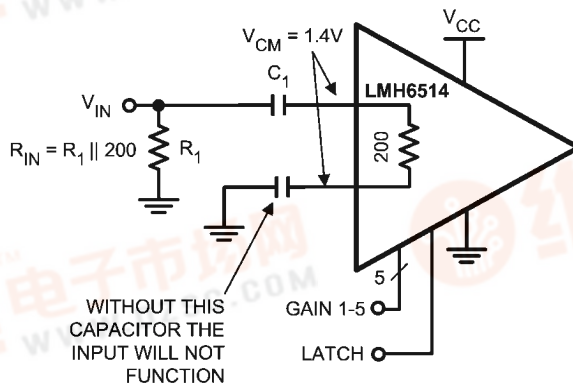

30059913

FIGURE 8. Schematic for Single- Ended Input



[查询LMH6514供应商](#)

For more National Semiconductor product information and proven design tools, visit the following Web sites at:

Products		Design Support	
Amplifiers	<a href="http://www.national.com/amplifiers">www.national.com/amplifiers</a>	WEBENCH	<a href="http://www.national.com/webench">www.national.com/webench</a>
Audio	<a href="http://www.national.com/audio">www.national.com/audio</a>	Analog University	<a href="http://www.national.com/AU">www.national.com/AU</a>
Clock Conditioners	<a href="http://www.national.com/timing">www.national.com/timing</a>	App Notes	<a href="http://www.national.com/appnotes">www.national.com/appnotes</a>
Data Converters	<a href="http://www.national.com/adc">www.national.com/adc</a>	Distributors	<a href="http://www.national.com/contacts">www.national.com/contacts</a>
Displays	<a href="http://www.national.com/displays">www.national.com/displays</a>	Green Compliance	<a href="http://www.national.com/quality/green">www.national.com/quality/green</a>
Ethernet	<a href="http://www.national.com/ethernet">www.national.com/ethernet</a>	Packaging	<a href="http://www.national.com/packaging">www.national.com/packaging</a>
Interface	<a href="http://www.national.com/interface">www.national.com/interface</a>	Quality and Reliability	<a href="http://www.national.com/quality">www.national.com/quality</a>
LVDS	<a href="http://www.national.com/lvds">www.national.com/lvds</a>	Reference Designs	<a href="http://www.national.com/refdesigns">www.national.com/refdesigns</a>
Power Management	<a href="http://www.national.com/power">www.national.com/power</a>	Feedback	<a href="http://www.national.com/feedback">www.national.com/feedback</a>
Switching Regulators	<a href="http://www.national.com/switchers">www.national.com/switchers</a>		
LDOs	<a href="http://www.national.com/ldo">www.national.com/ldo</a>		
LED Lighting	<a href="http://www.national.com/led">www.national.com/led</a>		
PowerWise	<a href="http://www.national.com/powerwise">www.national.com/powerwise</a>		
Serial Digital Interface (SDI)	<a href="http://www.national.com/sdi">www.national.com/sdi</a>		
Temperature Sensors	<a href="http://www.national.com/tempsensors">www.national.com/tempsensors</a>		
Wireless (PLL/VCO)	<a href="http://www.national.com/wireless">www.national.com/wireless</a>		

THE CONTENTS OF THIS DOCUMENT ARE PROVIDED IN CONNECTION WITH NATIONAL SEMICONDUCTOR CORPORATION ("NATIONAL") PRODUCTS. NATIONAL MAKES NO REPRESENTATIONS OR WARRANTIES WITH RESPECT TO THE ACCURACY OR COMPLETENESS OF THE CONTENTS OF THIS PUBLICATION AND RESERVES THE RIGHT TO MAKE CHANGES TO SPECIFICATIONS AND PRODUCT DESCRIPTIONS AT ANY TIME WITHOUT NOTICE. NO LICENSE, WHETHER EXPRESS, IMPLIED, ARISING BY ESTOPPEL OR OTHERWISE, TO ANY INTELLECTUAL PROPERTY RIGHTS IS GRANTED BY THIS DOCUMENT.

TESTING AND OTHER QUALITY CONTROLS ARE USED TO THE EXTENT NATIONAL DEEMS NECESSARY TO SUPPORT NATIONAL'S PRODUCT WARRANTY. EXCEPT WHERE MANDATED BY GOVERNMENT REQUIREMENTS, TESTING OF ALL PARAMETERS OF EACH PRODUCT IS NOT NECESSARILY PERFORMED. NATIONAL ASSUMES NO LIABILITY FOR APPLICATIONS ASSISTANCE OR BUYER PRODUCT DESIGN. BUYERS ARE RESPONSIBLE FOR THEIR PRODUCTS AND APPLICATIONS USING NATIONAL COMPONENTS. PRIOR TO USING OR DISTRIBUTING ANY PRODUCTS THAT INCLUDE NATIONAL COMPONENTS, BUYERS SHOULD PROVIDE ADEQUATE DESIGN, TESTING AND OPERATING SAFEGUARDS.

EXCEPT AS PROVIDED IN NATIONAL'S TERMS AND CONDITIONS OF SALE FOR SUCH PRODUCTS, NATIONAL ASSUMES NO LIABILITY WHATSOEVER, AND NATIONAL DISCLAIMS ANY EXPRESS OR IMPLIED WARRANTY RELATING TO THE SALE AND/OR USE OF NATIONAL PRODUCTS INCLUDING LIABILITY OR WARRANTIES RELATING TO FITNESS FOR A PARTICULAR PURPOSE, MERCHANTABILITY, OR INFRINGEMENT OF ANY PATENT, COPYRIGHT OR OTHER INTELLECTUAL PROPERTY RIGHT.

#### LIFE SUPPORT POLICY

**NATIONAL'S PRODUCTS ARE NOT AUTHORIZED FOR USE AS CRITICAL COMPONENTS IN LIFE SUPPORT DEVICES OR SYSTEMS WITHOUT THE EXPRESS PRIOR WRITTEN APPROVAL OF THE CHIEF EXECUTIVE OFFICER AND GENERAL COUNSEL OF NATIONAL SEMICONDUCTOR CORPORATION.** As used herein:

Life support devices or systems are devices which (a) are intended for surgical implant into the body, or (b) support or sustain life and whose failure to perform when properly used in accordance with instructions for use provided in the labeling can be reasonably expected to result in a significant injury to the user. A critical component is any component in a life support device or system whose failure to perform can be reasonably expected to cause the failure of the life support device or system or to affect its safety or effectiveness.

National Semiconductor and the National Semiconductor logo are registered trademarks of National Semiconductor Corporation. All other brand or product names may be trademarks or registered trademarks of their respective holders.

Copyright© 2008 National Semiconductor Corporation

For the most current product information visit us at [www.national.com](http://www.national.com)



**National Semiconductor  
Americas Technical  
Support Center**  
Email:  
[new.feedback@nsc.com](mailto:new.feedback@nsc.com)  
Tel: 1-800-272-9959

**National Semiconductor Europe  
Technical Support Center**  
Email: [europe.support@nsc.com](mailto:europe.support@nsc.com)  
German Tel: +49 (0) 180 5010 771  
English Tel: +44 (0) 870 850 4288

**National Semiconductor Asia  
Pacific Technical Support Center**  
Email: [ap.support@nsc.com](mailto:ap.support@nsc.com)

**National Semiconductor Japan  
Technical Support Center**  
Email: [jpn.feedback@nsc.com](mailto:jpn.feedback@nsc.com)