

LM3678 Evaluation Board

[查询LMH6515供应商](#)

National Semiconductor
Application Note 1722
Anne Lu
October 14, 2008



Introduction

The LM3678 evaluation board is a working demonstration of a synchronous buck DC-DC converter. This application note contains information about the evaluation board. For more details and electrical characteristics about the converter operation, please refer to the LM3678 datasheet.

Operating Range

- V_{IN} range: 2.5V to 5.5V
- Recommended load current: up to 1.5A
- $V_{OUT} = 0.8/1.2V$

Package

LLP-10 no-pullback (3mm x 3mm x 0.8mm)

Typical Application

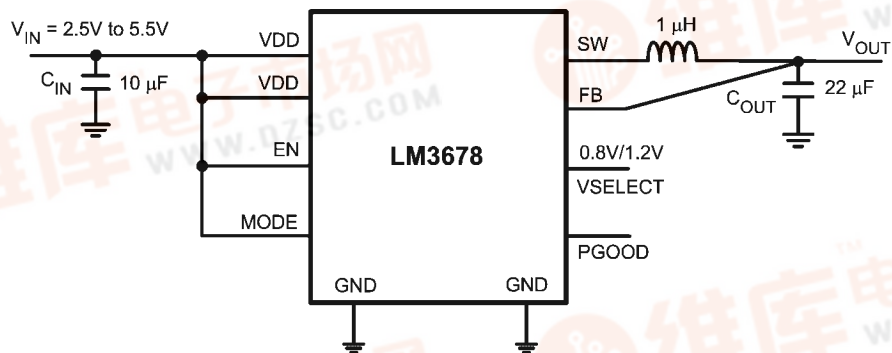
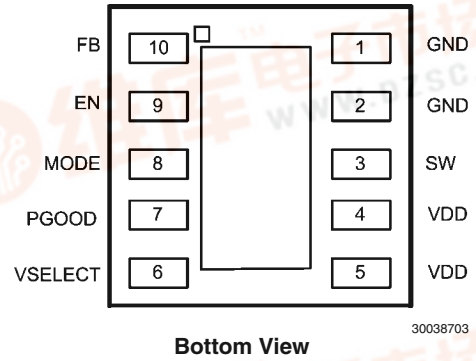
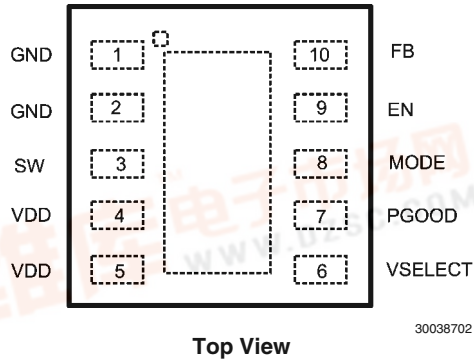

FIGURE 1. Typical Application Circuit

Connection Diagrams



Note: the above figures are not to any actual scale

Pin Descriptions

Pin#	Name	Description
1	GND	Ground
2	GND	
3	SW	Switching node connection to the internal PFET switch and NFET synchronous rectifier.
4	VDD	Power supply input. Connect to the input filter capacitor (<i>Figure 1</i>).
5	VDD	
6	VSELECT	Output Voltage Select. For Example : VSELECT = LOW $V_{OUT} = 0.8V$ VSELECT = HIGH, $V_{OUT} = 1.2V$
7	PGOOD	Power Good Flag. This common drain logic output is pulled to ground when the output voltage is not within $\pm 7.5\%$ of regulation.
8	MODE	Mode Control Pin: Mode = 1 selects forced PWM mode Mode = 0 selects auto PFM-PWM mode
9	EN	Enable Pin. The device is in shutdown mode when voltage to this pin $< 0.4V$ and enabled when $> 1.0V$. Do not leave this pin floating.
10	FB	Feedback Analog Input. Connect directly to the output filter capacitor for fixed voltage versions.
DAP	DAP	Die Attach Pad; connect the DAP to GND on PCB layout to enhance thermal performance. It should not be used as a primary ground connection.



Powering the LM3678 for Bench Measurements

When powering the LM3678 with a bench power supply, it is recommended to place a 100 μ F tantalum capacitor across the VIN and GND supply terminals of the bench power supply. This capacitor will reduce the input spike caused by the power supply and long power cables. The combination of the power supply and inductance within the power cables produce a large voltage spike that may damage the device. In addition, consideration must be given to the enable pin of the device. The enable should never be taken high, until minimum guaranteed operating voltage of 2.7V is reached. The enable pin should also never exceed the input voltage.

Operating Information

The LM3678 evaluation board is set for the following default positions:

- $V_{OUT} = 1.2V$, for 0.8V, set VSELECT pin to low via jumper
- Mode = H (PWM Mode), for Auto Mode, set Mode = Low (move jumper to inner position).
- EN pin is tied to V_{IN} via a jumper

Evaluation Board Layout

LM3678 is a four-layer board designed to maximize the performance. Top layer consists of high-current path and bottom layer for low-current and logic signals path. Inner layer 1 and layer 2 are dedicated for PGND (power GND) and SGND (analog and logic GND). For optimum performance, it is recommended to separate the PGND and SGND pins and join them together at the start GND on the PCB.

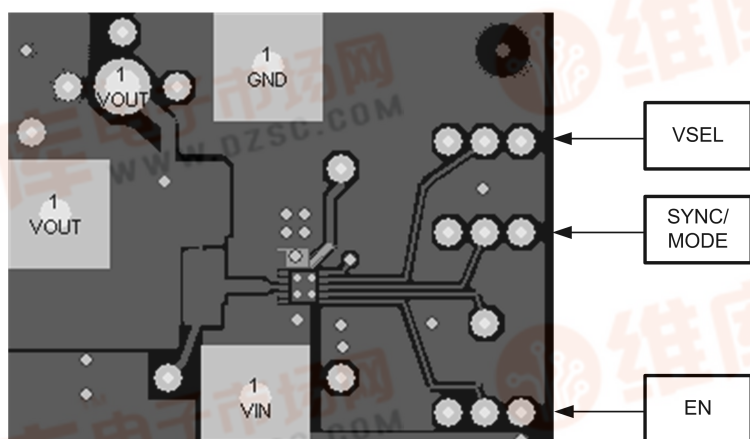

Top Layer

30038717

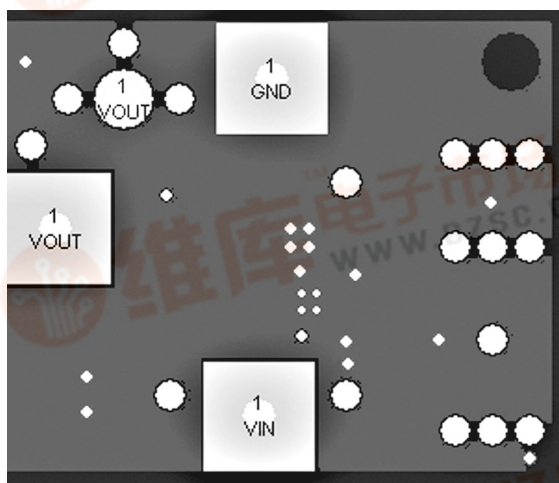

Mid Layer 1

30038718

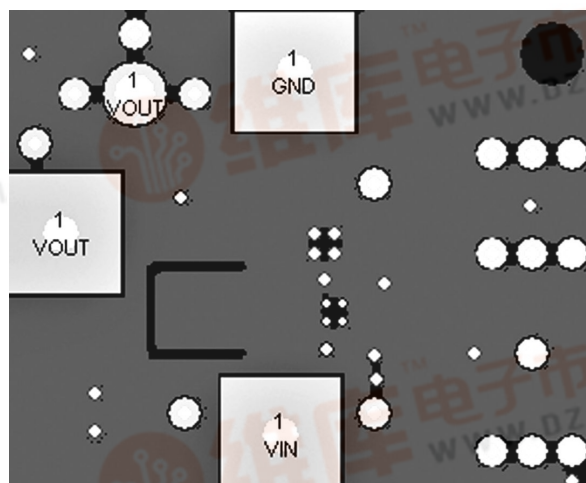

Mid Layer 2

30038719

[查询LMH6515供应商](#)

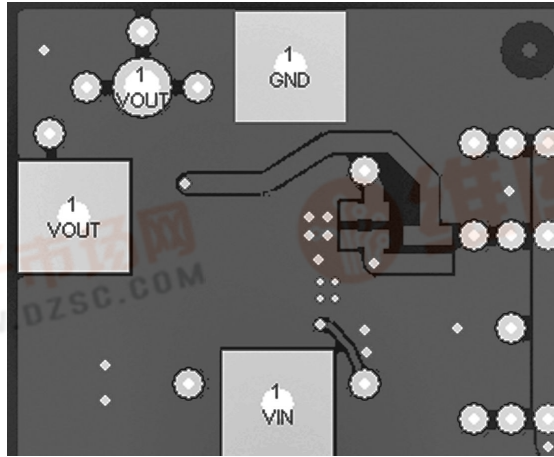

Bottom Layer

30038720

BOM for LM3678

BOM

Component Name	Manufacturer	Specification	Case Size
LM3678SD	NSC	LLP-10	3mm x 3mm x 0.8mm
C1 = 10 μ F	Taiyo-Yuden	JMK212BJ106K	0805 (2012)
C2 = 22 μ F		JMK212BJ226MG	0805 (2012)
Inductor	Taiyo-Yuden	NR4012T-1RON	4mm x 4mm x 1.2mm
R1	Vishay/any manufacturer	0603	0 Ω

TEST POINT

V _{SEL} , Mode & EN	Header	3 in series 3 (3 x 1)
V _{SEL} , Mode & EN	Jumper Female (Handle centerline)	A26242-ND
V _{IN} banana jack - red	Johnson Components	108-0902-001
V _{OUT} banana jack - yellow	Johnson Components	108-0907-001
GND banana jack - black	Johnson Components	108-0903-001

[查询LMH6515供应商](#)

Notes

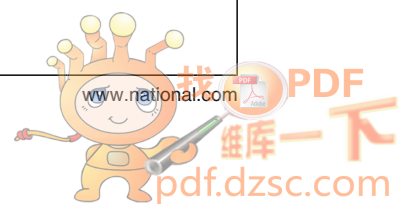

[查询LMH6515供应商](#)

Notes

For more National Semiconductor product information and proven design tools, visit the following Web sites at:

Products		Design Support	
Amplifiers	www.national.com/amplifiers	WEBENCH	www.national.com/webench
Audio	www.national.com/audio	Analog University	www.national.com/AU
Clock Conditioners	www.national.com/timing	App Notes	www.national.com/appnotes
Data Converters	www.national.com/adc	Distributors	www.national.com/contacts
Displays	www.national.com/displays	Green Compliance	www.national.com/quality/green
Ethernet	www.national.com/ethernet	Packaging	www.national.com/packaging
Interface	www.national.com/interface	Quality and Reliability	www.national.com/quality
LVDS	www.national.com/lvds	Reference Designs	www.national.com/refdesigns
Power Management	www.national.com/power	Feedback	www.national.com/feedback
Switching Regulators	www.national.com/switchers		
LDOs	www.national.com/lido		
LED Lighting	www.national.com/led		
PowerWise	www.national.com/powerwise		
Serial Digital Interface (SDI)	www.national.com/sdi		
Temperature Sensors	www.national.com/tempsensors		
Wireless (PLL/VCO)	www.national.com/wireless		

THE CONTENTS OF THIS DOCUMENT ARE PROVIDED IN CONNECTION WITH NATIONAL SEMICONDUCTOR CORPORATION ("NATIONAL") PRODUCTS. NATIONAL MAKES NO REPRESENTATIONS OR WARRANTIES WITH RESPECT TO THE ACCURACY OR COMPLETENESS OF THE CONTENTS OF THIS PUBLICATION AND RESERVES THE RIGHT TO MAKE CHANGES TO SPECIFICATIONS AND PRODUCT DESCRIPTIONS AT ANY TIME WITHOUT NOTICE. NO LICENSE, WHETHER EXPRESS, IMPLIED, ARISING BY ESTOPPEL OR OTHERWISE, TO ANY INTELLECTUAL PROPERTY RIGHTS IS GRANTED BY THIS DOCUMENT.

TESTING AND OTHER QUALITY CONTROLS ARE USED TO THE EXTENT NATIONAL DEEMS NECESSARY TO SUPPORT NATIONAL'S PRODUCT WARRANTY. EXCEPT WHERE MANDATED BY GOVERNMENT REQUIREMENTS, TESTING OF ALL PARAMETERS OF EACH PRODUCT IS NOT NECESSARILY PERFORMED. NATIONAL ASSUMES NO LIABILITY FOR APPLICATIONS ASSISTANCE OR BUYER PRODUCT DESIGN. BUYERS ARE RESPONSIBLE FOR THEIR PRODUCTS AND APPLICATIONS USING NATIONAL COMPONENTS. PRIOR TO USING OR DISTRIBUTING ANY PRODUCTS THAT INCLUDE NATIONAL COMPONENTS, BUYERS SHOULD PROVIDE ADEQUATE DESIGN, TESTING AND OPERATING SAFEGUARDS.

EXCEPT AS PROVIDED IN NATIONAL'S TERMS AND CONDITIONS OF SALE FOR SUCH PRODUCTS, NATIONAL ASSUMES NO LIABILITY WHATSOEVER, AND NATIONAL DISCLAIMS ANY EXPRESS OR IMPLIED WARRANTY RELATING TO THE SALE AND/OR USE OF NATIONAL PRODUCTS INCLUDING LIABILITY OR WARRANTIES RELATING TO FITNESS FOR A PARTICULAR PURPOSE, MERCHANTABILITY, OR INFRINGEMENT OF ANY PATENT, COPYRIGHT OR OTHER INTELLECTUAL PROPERTY RIGHT.

LIFE SUPPORT POLICY

NATIONAL'S PRODUCTS ARE NOT AUTHORIZED FOR USE AS CRITICAL COMPONENTS IN LIFE SUPPORT DEVICES OR SYSTEMS WITHOUT THE EXPRESS PRIOR WRITTEN APPROVAL OF THE CHIEF EXECUTIVE OFFICER AND GENERAL COUNSEL OF NATIONAL SEMICONDUCTOR CORPORATION. As used herein:

Life support devices or systems are devices which (a) are intended for surgical implant into the body, or (b) support or sustain life and whose failure to perform when properly used in accordance with instructions for use provided in the labeling can be reasonably expected to result in a significant injury to the user. A critical component is any component in a life support device or system whose failure to perform can be reasonably expected to cause the failure of the life support device or system or to affect its safety or effectiveness.

National Semiconductor and the National Semiconductor logo are registered trademarks of National Semiconductor Corporation. All other brand or product names may be trademarks or registered trademarks of their respective holders.

Copyright© 2008 National Semiconductor Corporation

For the most current product information visit us at www.national.com



National Semiconductor Americas Technical Support Center
Email: support@nsc.com
Tel: 1-800-272-9959

National Semiconductor Europe Technical Support Center
Email: europe.support@nsc.com
German Tel: +49 (0) 180 5010 771
English Tel: +44 (0) 870 850 4288

National Semiconductor Asia Pacific Technical Support Center
Email: ap.support@nsc.com

National Semiconductor Japan Technical Support Center
Email: jpn.feedback@nsc.com