

3-Phase Brushless DC Sinusoidal Sensorless Fan Motor Driver

Features

- Position Sensorless BLDC Drivers (No Hall Sensor Required)
- 180° Sinusoidal Drive, for High Efficiency and Low Acoustic Noise
- Support 2V to 14V Power Supplies
- Speed Control Through PAM and/or PWM
- Built-in Frequency Generator (FG Output Signal)
- Built-in Lock-up Protection and Automatic Recovery Circuit (External Capacitor not Necessary)
- Built-in Over Current Limitation and Short Circuit Protection
- Built-in Thermal Shutdown Protection
- Thermally Enhanced SOP-8 Package for MTD6501C; MSOP-10L Package for MTD6501D
- No External Tuning Required
- Boost Mode (Optional BEMF Pre-amplification in MTD6501D)

Note: The MTD6501C/MTD6501D devices are formerly products of Advanced Silicon.

Description

The MTD6501C/MTD6501D devices are 3-phase full-wave drivers for brushless sensorless DC motors. They feature 180° sinusoidal drive, high torque output, and silent drive. Due to their adaptive features and wide power-supply range capabilities (2V to 14V) they are intended to cover a wide range of motor characteristics, while requiring no external tuning from the user. Speed control can be achieved through either power supply modulation or pulse-width modulation (using the PWM digital input pin).

Due to the compact packaging and minimum bill-of-material (power transistors incorporated, no Hall sensor, no external tuning), they are best suited for low-cost fan applications requiring high efficiency and low acoustic noise, such as CPU cooling fans. Frequency generator output enables precision speed control in closed-loop applications. The MTD6501C/MTD6501D drivers include a lock-up protection mode, which turns off the output current when the motor is under lock condition, and an automatic recovery that enables the fan to run when the lock condition is removed. Motor overcurrent limitation, short-circuit protection, and thermal-shutdown protection are also included.

The MTD6501C is available in a compact thermally-enhanced SOP-8 package, while the MTD6501D is available in the MSOP-10L package.

Package Types

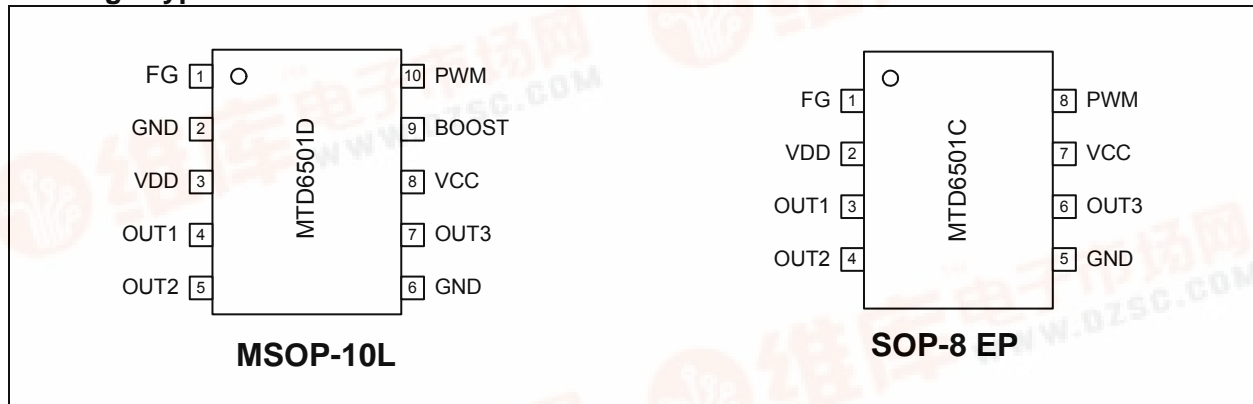

MTD6501C/MTD6501D

[查询MTD6501C供应商](#)

Functional Block Diagram

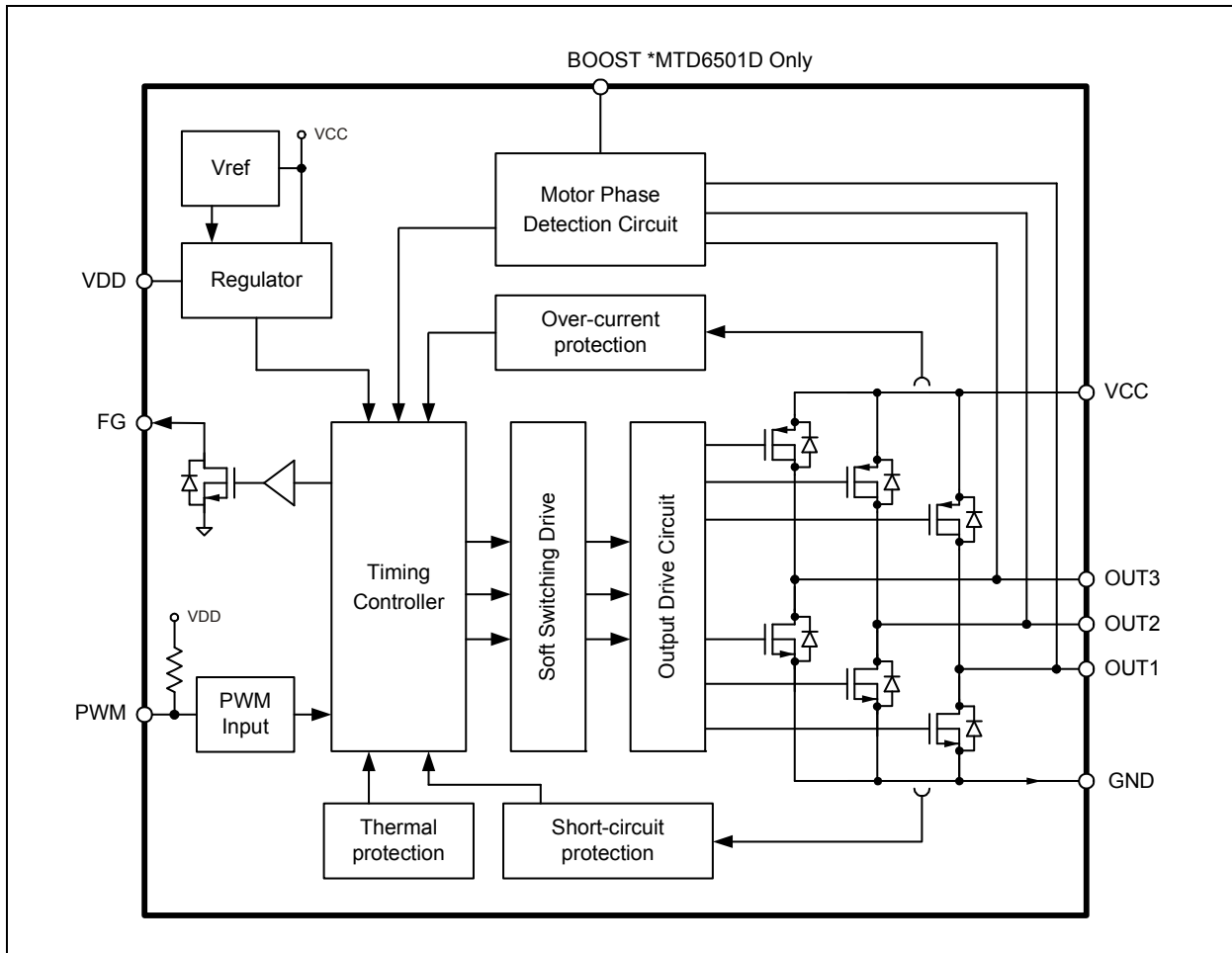

MTD6501C/MTD6501D

[查询MTD6501C供应商](#)

Typical Application – Fan Motor Driver Using the MTD6501C

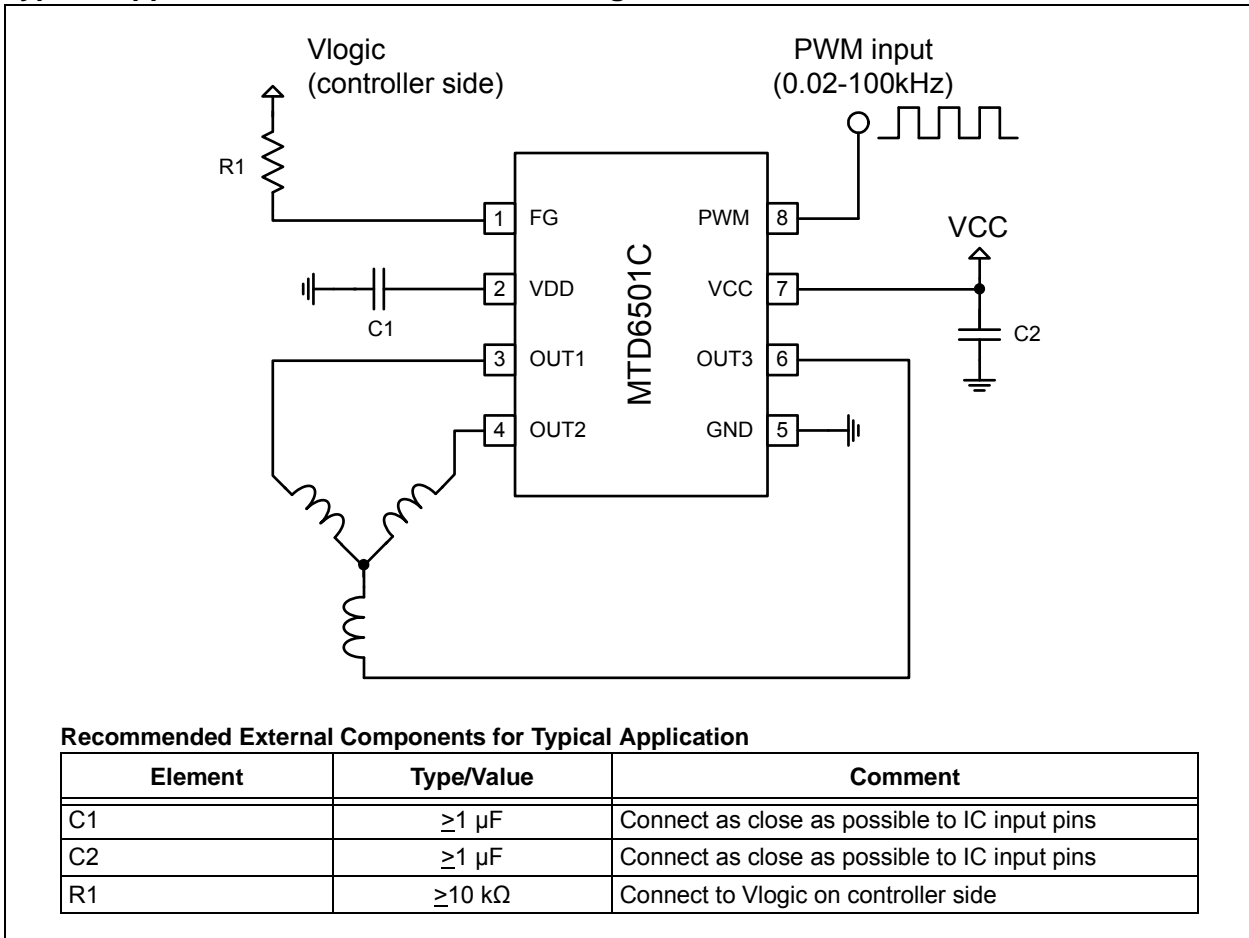

MTD6501C/MTD6501D

[查询MTD6501C供应商](#)

Typical Application – Fan Motor Driver Using the MTD6501D

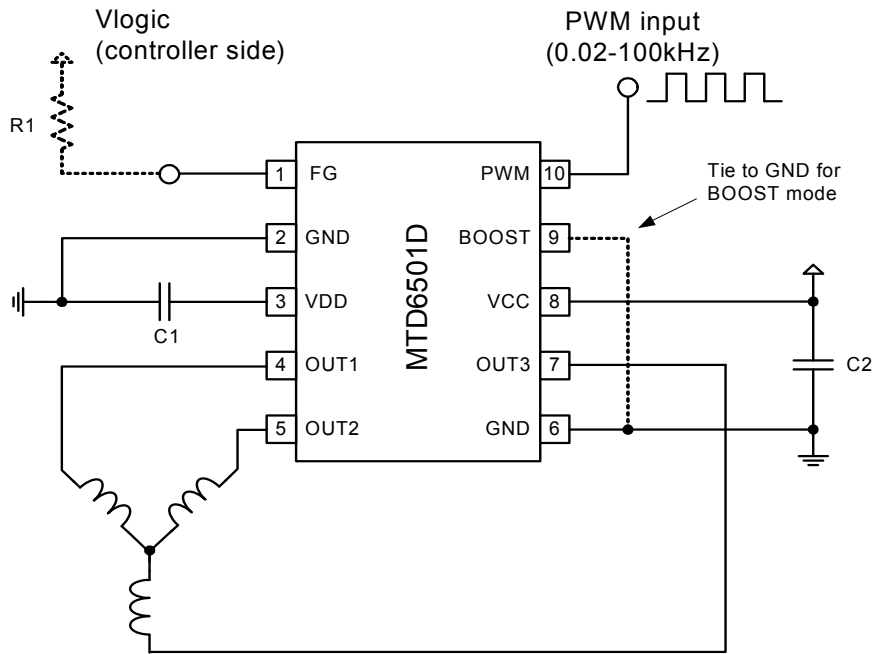

Recommended External Components for Typical Application

Element	Type/Value	Comment
C1	$\geq 1 \mu\text{F}$	Connect as close as possible to IC input pins
C2	$\geq 1 \mu\text{F}$	Connect as close as possible to IC input pins
R1	$\geq 10 \text{ k}\Omega$	Connect to Vlogic on controller side

MTD6501C/MTD6501D

查询MTD6501C供应商

1.0 ELECTRICAL CHARACTERISTICS

Absolute Maximum Ratings†

Power Supply Voltage (V_{CC_MAX})	-0.7 to +15.3V
Maximum OUT1, 2, 3 Output Voltage (V_{OUT_MAX})	-0.7 to +15.3V+0.7V
FG Maximum Output Voltage (V_{FG_MAX})	-0.7 to +15.3V
Maximum Output Current ^(3,4) (I_{OUT_MAX})	800 mA
Maximum Output Current ^(3,5) (I_{OUT_MAX})	500 mA
FG Maximum Output Voltage (V_{FG_MAX})	-0.7 to +15.3V
FG Maximum Output Current (I_{FG_MAX})	5.0 mA
V_{DD} Maximum Voltage (V_{DD_MAX})	-0.7 to +4.0V
PWM Maximum Voltage (V_{PWM_MAX})	-0.7 to +4.0V
Allowable Power Dissipation ^(1,2,4) (P_{D_MAX})	1.0W
Allowable Power Dissipation ^(1,2,5) (P_{D_MAX})	0.5W
Max Junction Temperature (T_J)	+150°C

† **Notice:** Stresses above those listed under “Maximum Ratings” may cause permanent damage to the device. This is a stress rating only and functional operation of the device at those or any other conditions above those indicated in the operational listings of this specification is not implied. Exposure to maximum rating conditions for extended periods may affect device reliability.

- Note 1:** Reference PCB, according to JEDEC standard EIA/JESD 51-9.
- 2:** De-rating applies for ambient temperatures outside the specified operating range (refer to Figure 1-1).
- 3:** OUT1, OUT2, OUT3 (Continuous, 100% duty cycle).
- 4:** MTD6501C
- 5:** MTD6501D

ELECTRICAL CHARACTERISTICS

Electrical Specifications: Unless otherwise specified, all limits are established for $V_{CC} = 5.0V$, $T_A = 25^\circ C$						
Parameters	Sym	Min	Typ	Max	Units	Conditions
Power Supply Voltage	V_{CC}	2	—	14	V	
Power Supply Current	I_{VCC}	—	10 5	—	mA mA	Rotation Mode Lock-Protection Mode
OUTx High Resistance	$R_{ON(H)}$	—	0.75	1	Ω	$I_{OUT} = 0.5A$, $V_{CC} = 3.3V$ to 14V
OUTx Low Resistance	$R_{ON(L)}$	—	0.75	1	Ω	$I_{OUT} = -0.5A$, $V_{CC} = 3.3V$ to 14V
OUTx Total Resistance	$R_{ON(H+L)}$	—	1.5	2	Ω	$I_{OUT} = 0.5A$, $V_{CC} = 3.3V$ to 14V
V_{DD} Output Voltage	V_{DD}	—	3 $V_{CC} - 0.2$	—	V V	$V_{CC} = 3.3V$ to 14V $V_{CC} < 3.3V$
PWM Input Frequency	f_{PWM}	0.02	—	100	kHz	—
PWM Input H Level	V_{PWM_H}	$0.8 \cdot V_{DD}$	—	3.6	V	—
PWM Input L Level	V_{PWM_L}	0	—	$0.2 \cdot V_{DD}$	V	—
PWM Internal Pull-Up Current	I_{PWM_L}	17 8	34 17	—	μA μA	PWM = GND, $V_{CC} = 3.3V$ to 14V PWM = GND, $V_{CC} < 3.3V$
FG Output Pin Low Level Voltage	V_{OL_FG}	—	—	0.25	V	$I_{FG} = -1$ mA
FG Output Pin Leakage Current	I_{LH_FG}	—	—	10	μA	$V_{FG} = 14V$
Lock Protection Operating Time	T_{RUN}	—	0.5	—	s	—
Lock Protection Waiting Time	T_{WAIT}	4.5	5	5.5	s	—
Thermal Shutdown	T_{SD}	—	170	—	$^\circ C$	—
Thermal Shutdown Hysteresis	T_{SD_HYS}	—	25	—	$^\circ C$	—

MTD6501C/MTD6501D

[查询MTD6501C供应商](#)

TEMPERATURE SPECIFICATIONS

Electrical Specifications: Unless otherwise specified, all limits are established for $V_{CC} = 5.0V$, $T_A = 25^\circ C$

Parameters	Sym	Min	Typ	Max	Units	Conditions
Temperature Ranges						
Operating Temperature	T_{OPR}	-10	—	+85	$^\circ C$	MTD6501C
Operating Temperature	T_{OPR}	-30	—	+95	$^\circ C$	MTD6501D
Storage Temperature Range	T_{STG}	-55	—	+150	$^\circ C$	

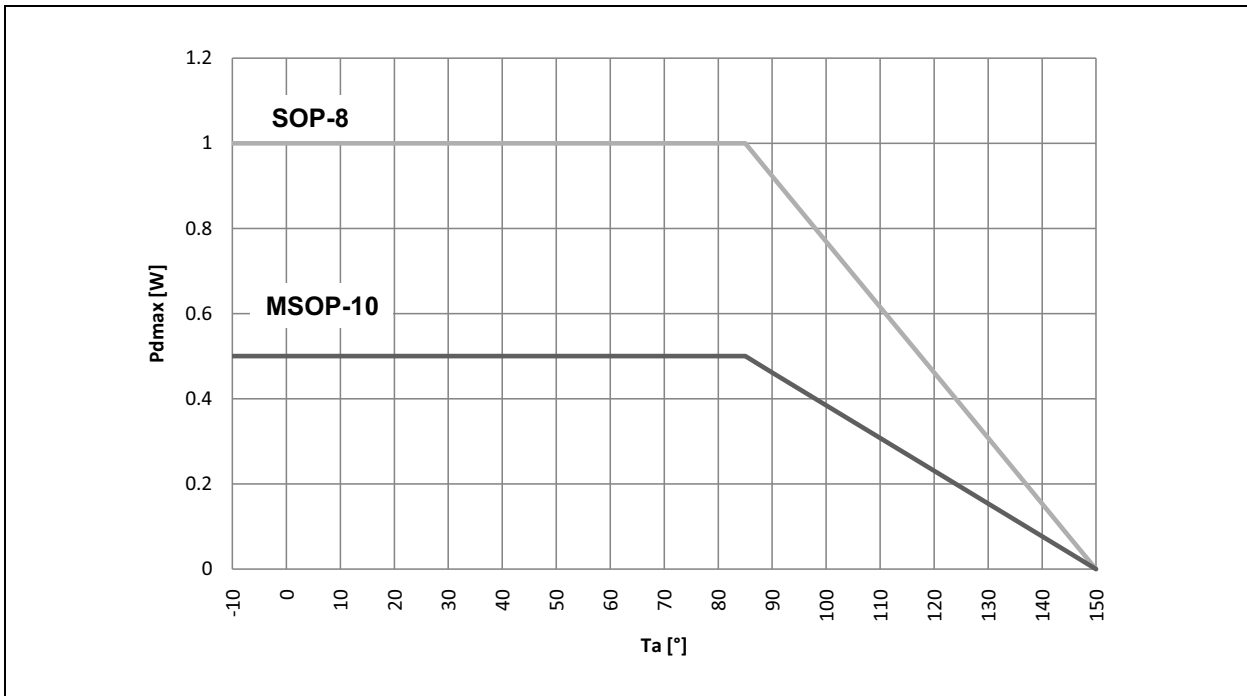

FIGURE 1-1: Allowable Power Dissipation (P_{D_MAX}) as a Function of Ambient Temperature (T_A)

MTD6501C/MTD6501D

[查询MTD6501C供应商](#)

2.0 PIN DESCRIPTIONS

The descriptions of the pins are listed in [Table 2-1](#).

TABLE 2-1: MTD6501C/MTD6501D PIN FUNCTION TABLE

Pin Number: MTD6501C	Pin Number: MTD6501D	Type	Name	Function
7	8	P	V _{CC}	Positive voltage supply for motor driver
5	2, 6	P	GND	Negative voltage supply (ground)
3	4	O	OUT1	Single phase coil output pin
4	5	O	OUT2	Single phase coil output pin
6	7	O	OUT3	Single phase coil output pin
8	10	I	PWM	PWM input signal for speed control
1	1	O	FG	Motor speed indication output (MTD6501C: FG)
2	3	P	V _{DD}	Internal regulator output (for decoupling only)
N/A	9	I	BOOST	Boost mode selection: <ul style="list-style-type: none">• Pin floating for Normal mode• Pin tied to GND for Boost mode

Legend: I = Input; O = Output; P = Power

MTD6501C/MTD6501D

[查询MTD6501C供应商](#)

3.0 FUNCTIONAL DESCRIPTION

The MTD6501C/MTD6501D devices generate a full-wave signal to drive a 3-phase sensorless BLDC motor. High efficiency and low-power consumption are achieved due to DMOS transistors and synchronous rectification drive type. The current carrying order of the outputs is as follows: OUT1 -> OUT2 -> OUT3.

3.1 Speed Control

The rotational speed of the motor can be controlled either through the PWM digital input signal or by acting directly on the power supply (V_{CC}). When the PWM signal is “High” (or left open) the motor rotates at full speed. When the PWM signal is “Low” the motor is stopped (and the IC outputs are set to high-impedance). By changing the PWM duty cycle, the speed can be adjusted. Notice that the PWM frequency has no special meaning for the motor speed and is asynchronous with the activation of the output transistors. Thus the user has maximum freedom to choose the PWM system frequency within a wide range (from 20 Hz to 100 kHz), while the output transistor activation always occurs at a fixed rate (20 kHz, typ.), which is outside of the range of audible frequencies.

3.2 Frequency Generator Function

The Frequency Generator output (FG) is a “Hall-sensor equivalent” digital output, giving information to an external controller about the speed and phase of the motor. The FG pin is an open collector output, connecting to a logical voltage level through an external pull-up resistor. When a lock (or out-of-sync) situation is detected by the driver, this output is set to high-impedance until the motor is restarted. Leave the pin open when not used.

3.3 Lockup Protection and Automatic Restart

If the motor is stopped (blocked) or if it loses synchronization with the driver, a lock-up protection circuit detects this situation and disables the driver (by setting its outputs to high-impedance) in order to prevent the motor coil from burnout. After a “waiting time” (T_{WAIT}), the lock-up protection is released and normal operation resumes for a given time (T_{RUN}). In case the motor is still blocked, a new period of waiting time is started. T_{WAIT} and T_{RUN} timings are fixed internally, so that no external capacitor is needed.

3.4 Overcurrent Protection and Short Circuit Detection

The motor peak current is limited by the driver to a fixed value (defined internally), thus limiting the maximum power dissipation in the coils. The detection of a short-circuit situation immediately sets the driver outputs to high-impedance, in order to avoid permanent damage to the IC.

3.5 Thermal Shutdown

The MTD6501C/MTD6501D have a thermal protection function which detects when the die temperature exceeds $T_J = 170^{\circ}\text{C}$. When this temperature is reached, the circuit enters the thermal shutdown mode and the outputs OUT1, OUT2 and OUT3 are disabled (high-impedance), avoiding IC destruction and allowing the circuit to cool down. Once the junction temperature (T_J) has dropped below 145°C , the normal operation resumes (thermal detection circuit has 25°C hysteresis function).

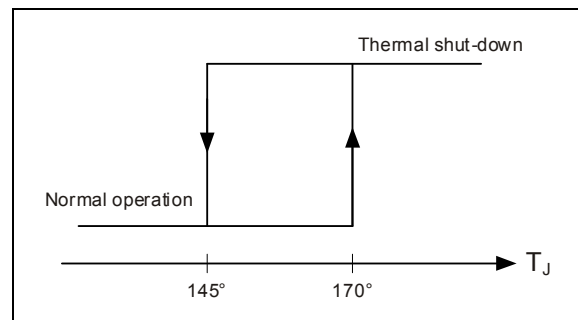

FIGURE 3-1: Thermal Protection Hysteresis

3.6 Internal Voltage Regulator

V_{DD} voltage is generated internally and is used to supply internal logical blocks. The V_{DD} pin is used to connect an external decoupling capacitor ($1\mu\text{F}$ or higher). Notice that this pin is for IC internal use and is not designed to supply DC current to external blocks.

3.7 Boost Mode (MTD6501D)

The Boost mode is an optional BEMF pre-amplification by a factor of 3. The interest of the Boost mode is to compensate for motors with a low coupling coefficient (= BEMF coefficient), thus allowing to cover an even wider range of motor characteristics. Notice that the Boost mode impacts the mechanical performance of the motor altogether. In Boost mode, the speed of the motor will adjust faster to variations of the control (V_{CC} or PWM) and/or of the load, including at start-up. On the other hand, however, when the BEMF is amplified too much, the mechanical performance (in terms of vibration and acoustic noise) may start degrading. Thus, the Boost mode may be inappropriate, for motors that already have a good coupling coefficient. The optimum choice (between normal mode and Boost mode) depends both on the application requirements and on the motor characteristics.

Refer to Table 3-1 for the usage of the “BOOST” pin #9: leaving this pin floating results the normal mode of operation, tying this pin to GND activates the Boost mode.

TABLE 3-1: POSSIBLE MODES OF OPERATION BASED ON THE BOOST PIN CONNECTION

BOOST Pin	Mode of Operation
Floating	Normal
Tied to GND	Boost

MTD6501C/MTD6501D

[查询MTD6501C供应商](#)

4.0 PACKAGE OUTLINES

Thermally Enhanced SOP-8 Package

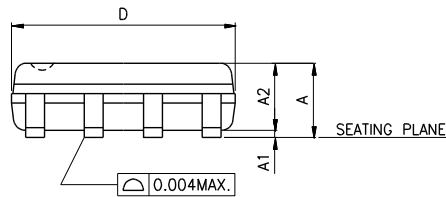
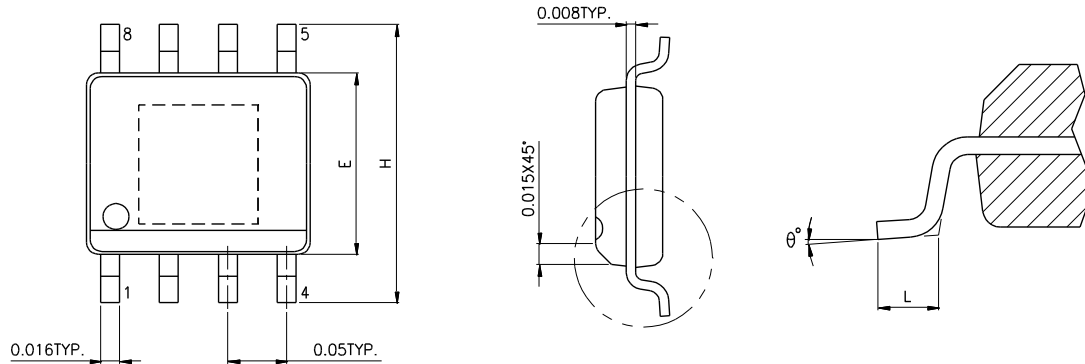

SYMBOLS	MIN.	MAX.
A	0.053	0.069
A1	0.000	0.006
A2	—	0.059
D	0.189	0.196
E	0.150	0.157
H	0.228	0.244
L	0.016	0.050
θ°	0	8

UNIT : INCH

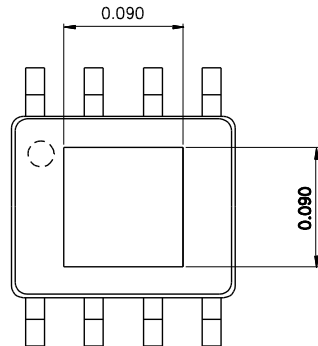

NOTES:

1. JEDEC OUTLINE : N/A
2. DIMENSIONS "D" DOES NOT INCLUDE MOLD FLASH, PROTRUSIONS OR GATE BURRS. MOLD FLASH, PROTRUSIONS AND GATE BURRS SHALL NOT EXCEED .15mm (.006in) PER SIDE.
3. DIMENSIONS "E" DOES NOT INCLUDE INTER-LEAD FLASH, OR PROTRUSIONS. INTER-LEAD FLASH AND PROTRUSIONS SHALL NOT EXCEED .25mm (.010in) PER SIDE.

SOP-8 Package Thermal Information

Symbol	Description	Conditions	Value	Unit
Theta_JA	Thermal Resistance Junction to Ambient	Reference PCB, according to JEDEC Standard EIA/JESD 51-9	65	°C/W
Theta_JC	Thermal Resistance Junction to Case		TBD	°C/W

MTD6501C/MTD6501D

查询MTD6501C供应商

MSOP-10L Package

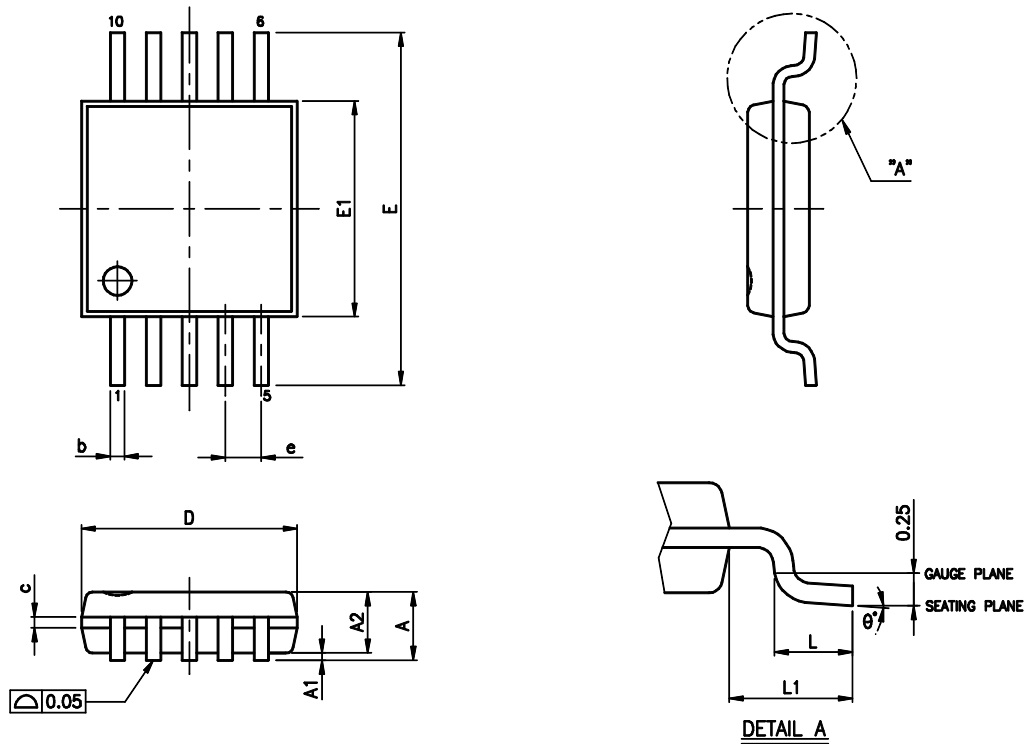

SYMBOLS	MIN.	NOM.	MAX.
A	—	—	1.10
A1	0.00	—	0.15
A2	0.75	0.85	0.95
b	0.17	—	0.27
c	0.08	—	0.23
D	3.00 BSC		
E	4.90 BSC		
E1	3.00 BSC		
e	0.50 BSC		
L	0.40	0.60	0.80
L1	0.95 REF		
θ^*	0	—	8

UNIT : MM

NOTES:

1. DIMENSION 'D' DOES NOT INCLUDE MOLD FLASH, PROTRUSIONS OR GATE BURRS. MOLD FLASH, PROTRUSIONS OR GATE BURRS SHALL NOT EXCEED 0.15 PER SIDE.
2. DIMENSION 'E1' DOES NOT INCLUDE INTERLEAD FLASH OR PROTRUSION. INTERLEAD FLASH OR PROTRUSION SHALL NOT EXCEED 0.25 PER SIDE.
3. DIMENSION '0.22' DOES NOT INCLUDE DAMBAR PROTRUSION. ALLOWABLE DAMBAR PROTRUSION SHALL BE 0.08 MM TOTAL IN EXCESS OF THE '0.22' DIMENSION AT MAXIMUM MATERIAL CONDITION. DAMBAR CANNOT BE LOCATED ON THE LOWER RADIUS OF THE FOOT. MINIMUM SPAC BETWEEN PROTRUSION AND ADJACENT LEAD IS 0.07 MM.
4. DIMENSIONS 'D' AND 'L1' TO BE DETERMINED AT DATUM PLANE \square .

SOP-8 Package Thermal Information

Symbol	Description	Conditions	Value	Unit
Theta_JA	Thermal Resistance Junction to Ambient	Reference PCB, according to JEDEC Standard EIA/JESD 51-9	120	°C/W
Theta_JC	Thermal Resistance Junction to Case		45	°C/W

MTD6501C/MTD6501D

[查询MTD6501C供应商](#)

NOTES:

[查询MTD6501C供应商](#)

APPENDIX A: REVISION HISTORY

Revision A (September 2010)

- Original Release of this Document.

MTD6501C/MTD6501D

[查询MTD6501C供应商](#)

NOTES:

Note the following details of the code protection feature on Microchip devices:

- Microchip products meet the specification contained in their particular Microchip Data Sheet.
- Microchip believes that its family of products is one of the most secure families of its kind on the market today, when used in the intended manner and under normal conditions.
- There are dishonest and possibly illegal methods used to breach the code protection feature. All of these methods, to our knowledge, require using the Microchip products in a manner outside the operating specifications contained in Microchip's Data Sheets. Most likely, the person doing so is engaged in theft of intellectual property.
- Microchip is willing to work with the customer who is concerned about the integrity of their code.
- Neither Microchip nor any other semiconductor manufacturer can guarantee the security of their code. Code protection does not mean that we are guaranteeing the product as "unbreakable."

Code protection is constantly evolving. We at Microchip are committed to continuously improving the code protection features of our products. Attempts to break Microchip's code protection feature may be a violation of the Digital Millennium Copyright Act. If such acts allow unauthorized access to your software or other copyrighted work, you may have a right to sue for relief under that Act.

Information contained in this publication regarding device applications and the like is provided only for your convenience and may be superseded by updates. It is your responsibility to ensure that your application meets with your specifications. MICROCHIP MAKES NO REPRESENTATIONS OR WARRANTIES OF ANY KIND WHETHER EXPRESS OR IMPLIED, WRITTEN OR ORAL, STATUTORY OR OTHERWISE, RELATED TO THE INFORMATION, INCLUDING BUT NOT LIMITED TO ITS CONDITION, QUALITY, PERFORMANCE, MERCHANTABILITY OR FITNESS FOR PURPOSE. Microchip disclaims all liability arising from this information and its use. Use of Microchip devices in life support and/or safety applications is entirely at the buyer's risk, and the buyer agrees to defend, indemnify and hold harmless Microchip from any and all damages, claims, suits, or expenses resulting from such use. No licenses are conveyed, implicitly or otherwise, under any Microchip intellectual property rights.

Trademarks

The Microchip name and logo, the Microchip logo, dsPIC, KEELOQ, KEELOQ logo, MPLAB, PIC, PICmicro, PICSTART, PIC³² logo, rPIC and UNI/O are registered trademarks of Microchip Technology Incorporated in the U.S.A. and other countries.

FilterLab, Hampshire, HI-TECH C, Linear Active Thermistor, MXDEV, MXLAB, SEEVAL and The Embedded Control Solutions Company are registered trademarks of Microchip Technology Incorporated in the U.S.A.

Analog-for-the-Digital Age, Application Maestro, CodeGuard, dsPICDEM, dsPICDEM.net, dsPICworks, dsSPEAK, ECAN, ECONOMONITOR, FanSense, HI-TIDE, In-Circuit Serial Programming, ICSP, Mindi, MiWi, MPASM, MPLAB Certified logo, MPLIB, MPLINK, mTouch, Omniscient Code Generation, PICC, PICC-18, PICDEM, PICDEM.net, PICkit, PICTail, REAL ICE, rLAB, Select Mode, Total Endurance, TSHARC, UniWinDriver, WiperLock and ZENA are trademarks of Microchip Technology Incorporated in the U.S.A. and other countries.

SQTP is a service mark of Microchip Technology Incorporated in the U.S.A.

All other trademarks mentioned herein are property of their respective companies.

© 2010, Microchip Technology Incorporated, Printed in the U.S.A., All Rights Reserved.

 Printed on recycled paper.

ISBN: 978-1-60932-560-2

Microchip received ISO/TS-16949:2002 certification for its worldwide headquarters, design and wafer fabrication facilities in Chandler and Tempe, Arizona; Gresham, Oregon and design centers in California and India. The Company's quality system processes and procedures are for its PIC® MCUs and dsPIC® DSCs, KEELOQ® code hopping devices, Serial EEPROMs, microperipherals, nonvolatile memory and analog products. In addition, Microchip's quality system for the design and manufacture of development systems is ISO 9001:2000 certified.

**QUALITY MANAGEMENT SYSTEM
CERTIFIED BY DNV
== ISO/TS 16949:2002 ==**

Worldwide Sales and Service

AMERICAS

Corporate Office
2355 West Chandler Blvd.
Chandler, AZ 85224-6199
Tel: 480-792-7200
Fax: 480-792-7277
Technical Support:
<http://support.microchip.com>
Web Address:
www.microchip.com

Atlanta
Duluth, GA
Tel: 678-957-9614
Fax: 678-957-1455

Boston
Westborough, MA
Tel: 774-760-0087
Fax: 774-760-0088

Chicago
Itasca, IL
Tel: 630-285-0071
Fax: 630-285-0075

Cleveland
Independence, OH
Tel: 216-447-0464
Fax: 216-447-0643

Dallas
Addison, TX
Tel: 972-818-7423
Fax: 972-818-2924

Detroit
Farmington Hills, MI
Tel: 248-538-2250
Fax: 248-538-2260

Kokomo
Kokomo, IN
Tel: 765-864-8360
Fax: 765-864-8387

Los Angeles
Mission Viejo, CA
Tel: 949-462-9523
Fax: 949-462-9608

Santa Clara
Santa Clara, CA
Tel: 408-961-6444
Fax: 408-961-6445

Toronto
Mississauga, Ontario,
Canada
Tel: 905-673-0699
Fax: 905-673-6509

ASIA/PACIFIC

Asia Pacific Office
Suites 3707-14, 37th Floor
Tower 6, The Gateway
Harbour City, Kowloon
Hong Kong
Tel: 852-2401-1200
Fax: 852-2401-3431

Australia - Sydney
Tel: 61-2-9868-6733
Fax: 61-2-9868-6755

China - Beijing
Tel: 86-10-8528-2100
Fax: 86-10-8528-2104

China - Chengdu
Tel: 86-28-8665-5511
Fax: 86-28-8665-7889

China - Chongqing
Tel: 86-23-8980-9588
Fax: 86-23-8980-9500

China - Hong Kong SAR
Tel: 852-2401-1200
Fax: 852-2401-3431

China - Nanjing
Tel: 86-25-8473-2460
Fax: 86-25-8473-2470

China - Qingdao
Tel: 86-532-8502-7355
Fax: 86-532-8502-7205

China - Shanghai
Tel: 86-21-5407-5533
Fax: 86-21-5407-5066

China - Shenyang
Tel: 86-24-2334-2829
Fax: 86-24-2334-2393

China - Shenzhen
Tel: 86-755-8203-2660
Fax: 86-755-8203-1760

China - Wuhan
Tel: 86-27-5980-5300
Fax: 86-27-5980-5118

China - Xian
Tel: 86-29-8833-7252
Fax: 86-29-8833-7256

China - Xiamen
Tel: 86-592-2388138
Fax: 86-592-2388130

China - Zhuhai
Tel: 86-756-3210040
Fax: 86-756-3210049

ASIA/PACIFIC

India - Bangalore
Tel: 91-80-3090-4444
Fax: 91-80-3090-4123

India - New Delhi
Tel: 91-11-4160-8631
Fax: 91-11-4160-8632

India - Pune
Tel: 91-20-2566-1512
Fax: 91-20-2566-1513

Japan - Yokohama
Tel: 81-45-471- 6166
Fax: 81-45-471-6122

Korea - Daegu
Tel: 82-53-744-4301
Fax: 82-53-744-4302

Korea - Seoul
Tel: 82-2-554-7200
Fax: 82-2-558-5932 or
82-2-558-5934

Malaysia - Kuala Lumpur
Tel: 60-3-6201-9857
Fax: 60-3-6201-9859

Malaysia - Penang
Tel: 60-4-227-8870
Fax: 60-4-227-4068

Philippines - Manila
Tel: 63-2-634-9065
Fax: 63-2-634-9069

Singapore
Tel: 65-6334-8870
Fax: 65-6334-8850

Taiwan - Hsin Chu
Tel: 886-3-6578-300
Fax: 886-3-6578-370

Taiwan - Kaohsiung
Tel: 886-7-213-7830
Fax: 886-7-330-9305

Taiwan - Taipei
Tel: 886-2-2500-6610
Fax: 886-2-2508-0102

Thailand - Bangkok
Tel: 66-2-694-1351
Fax: 66-2-694-1350

EUROPE

Austria - Wels
Tel: 43-7242-2244-39
Fax: 43-7242-2244-393

Denmark - Copenhagen
Tel: 45-4450-2828
Fax: 45-4485-2829

France - Paris
Tel: 33-1-69-53-63-20
Fax: 33-1-69-30-90-79

Germany - Munich
Tel: 49-89-627-144-0
Fax: 49-89-627-144-44

Italy - Milan
Tel: 39-0331-742611
Fax: 39-0331-466781

Netherlands - Drunen
Tel: 31-416-690399
Fax: 31-416-690340

Spain - Madrid
Tel: 34-91-708-08-90
Fax: 34-91-708-08-91

UK - Wokingham
Tel: 44-118-921-5869
Fax: 44-118-921-5820