

Dual Full-Bridge Motor Driver

Features

- 750 mA Continuous Output Current
- Load Voltage Supply: 10V to 40V
- Full Bipolar Stepper Motor Drive Capability
- Bidirectional DC Motor Capability
- Internal Fixed T_{OFF} Time PWM Current Control
- Internal Protection Diodes
- Internal Thermal Shutdown
- Under Voltage Lockout
- LS-TTL Compatible Logic Inputs with Pull-Up Resistors
- Low R_{ON} Output Resistance
- Low Quiescent Current
- Operating Temperature Range: -20°C to $+85^{\circ}\text{C}$
- Pin Compatible with Allegro 6219

Applications

- Stepper Motor Actuators
- DC Motor Actuators
- Automotive HVAC Ventilation
- Automotive Power Seats

Note: The MTS62C19A device is formerly a product of Advanced Silicon.

Description

The MTS62C19A motor driver is a CMOS device capable of driving both windings of a bipolar stepper motor or bidirectionally control two DC motors. Each of the two independent H-bridge outputs is capable of sustaining 40V and delivering up to 750 mA of continuous current. The output current level is controlled by an internal PWM circuit that is configured using two logic inputs, a current sense resistor, and a selectable reference voltage. The H-bridge outputs have been optimized to provide a low output saturation voltage drop.

Full, half, and micro-stepping operations are possible with the PWM current control and logic inputs. The maximum output current is set by a sensing resistor and a user selectable reference voltage. The output current limit is selected using two logic level inputs. The selectable output current limits are 0%, 33%, 67%, or 100% of the maximum output current. Each bridge has a PHASE input signal which is used to control the direction of current flow through the H-bridge and the load.

The H-bridge power stage is controlled by non-overlapping signals which prevent current cross conduction when switching the direction of the current flow. Internal clamp diodes protect against inductive transients. Thermal protection circuitry disables the outputs when the junction temperature exceeds the safe operating limit. No special power-up sequencing is required. Undervoltage Lockout circuitry prevents the chip from operating when the load supply is applied prior to the logic supply.

The device is supplied in a 24-pin SOP Package.

Package Types

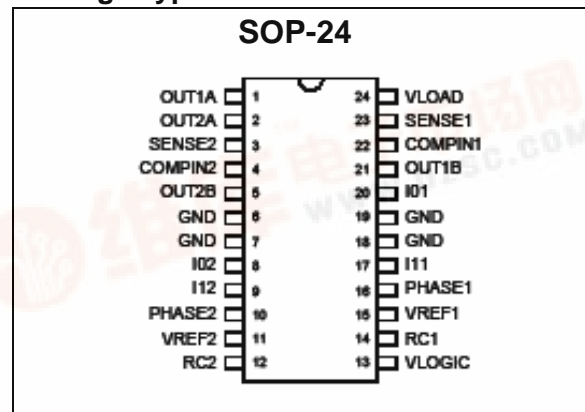

MTS62C19A

[查询MTS62C19A供应商](#)

Functional Block Diagram

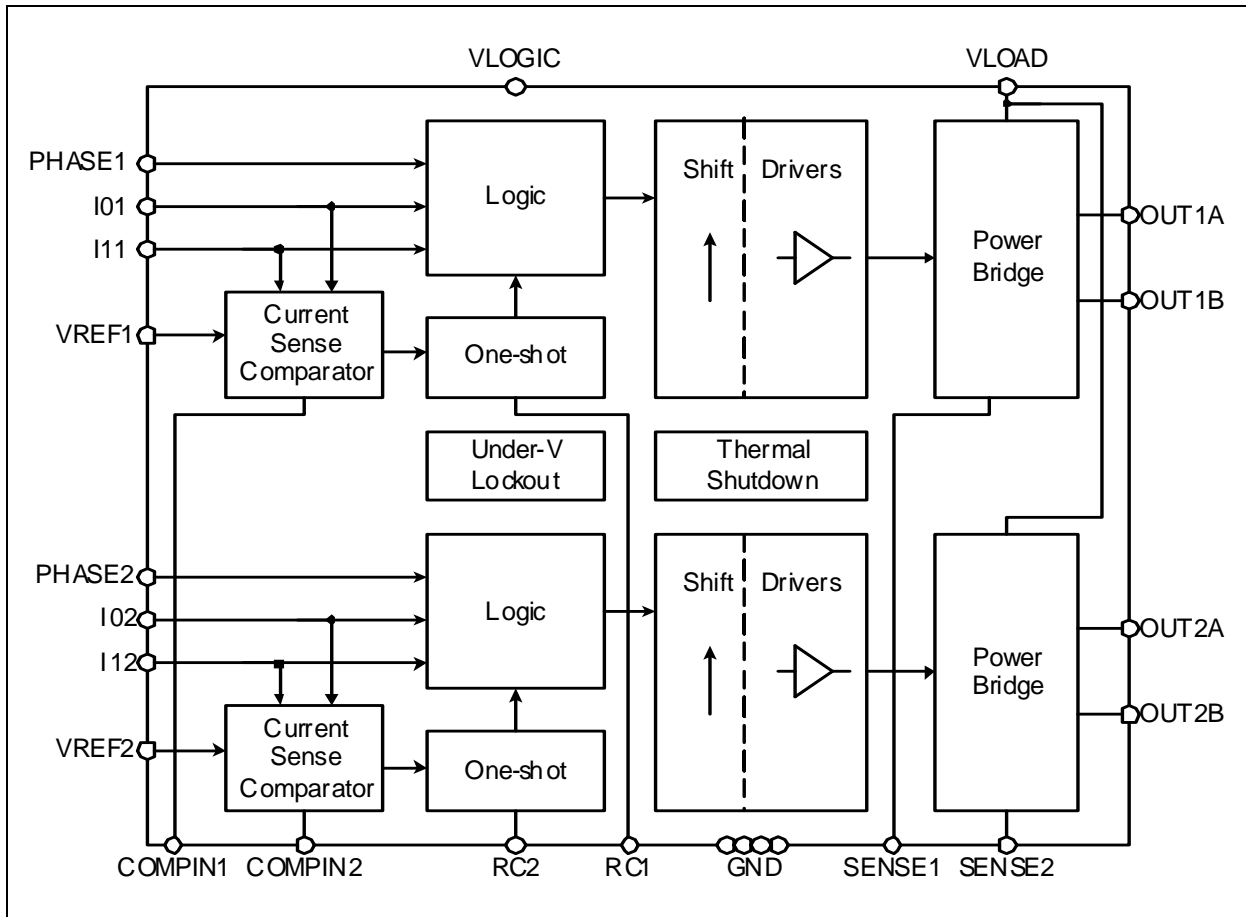

Typical Application

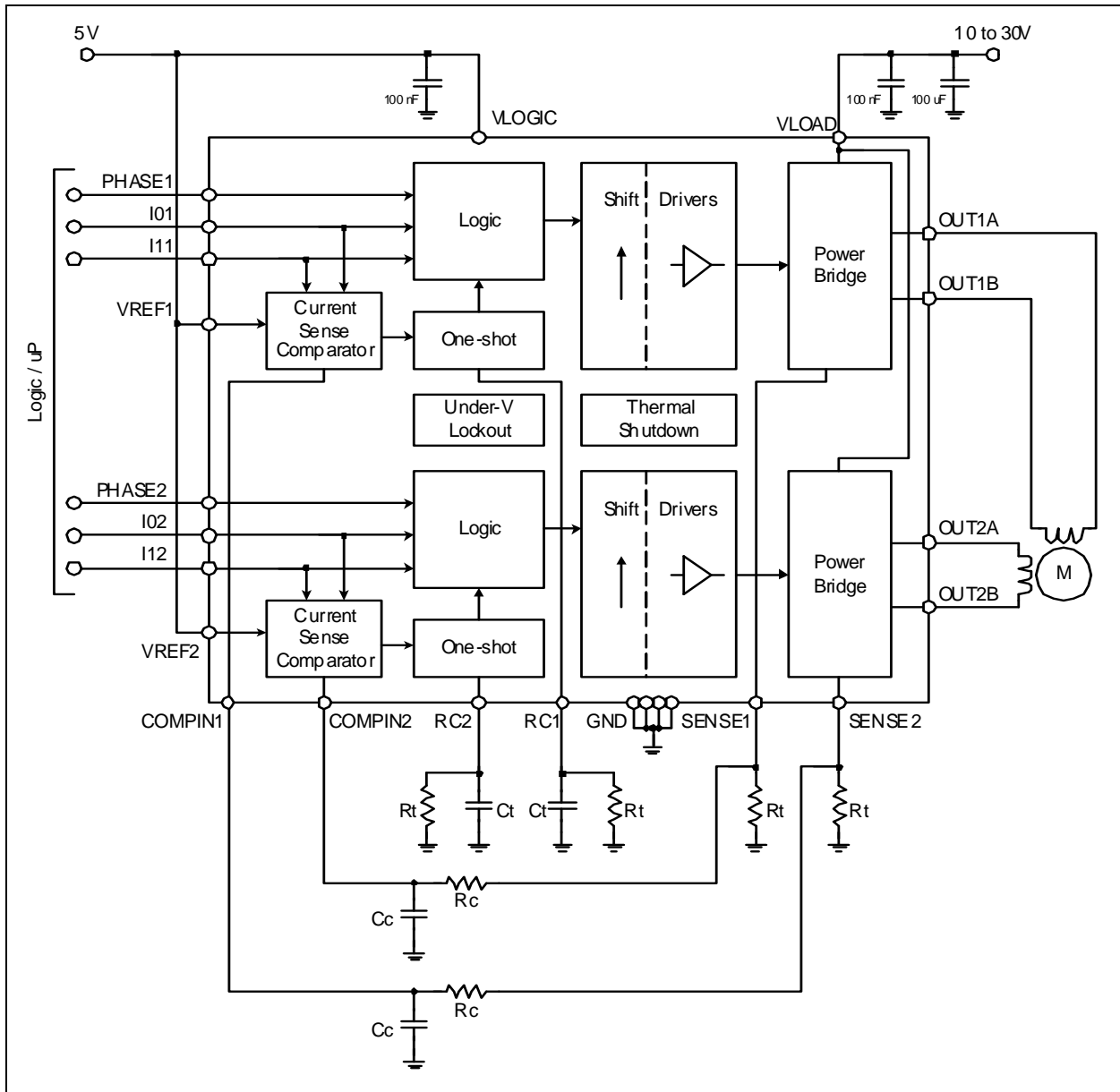

MTS62C19A

[查询MTS62C19A供应商](#)

1.0 ELECTRICAL CHARACTERISTICS

Absolute Maximum Ratings †

Logic Supply Voltage (V_{LOGIC})	-0.3 to +5.5V
Load Supply Voltage (V_{LOAD})	-0.3 to +40.0V
Logic Input Voltage Range (V_{IN})	-0.3 to $V_{\text{LOGIC}} + 0.3\text{V}$
V_{REF} Voltage Range (V_{REF})	-0.3 to +10.0V
Output Current (Peak)	$\pm 1\text{A}$
Output Current (Continuous)	$\pm 0.75\text{A}$
Sense Output Voltage	-0.3V to 1.5V
Junction Temperature (T_{J})	-20°C to +150°C
Operating Temperature Range (T_{OPR})	-20°C to +85°C
Storage Temperature Range (T_{STG})	-55°C to +150°C

† **Notice:** Stresses above those listed under “Maximum Ratings” may cause permanent damage to the device. This is a stress rating only and functional operation of the device at those or any other conditions above those indicated in the operational listings of this specification is not implied. Exposure to maximum rating conditions for extended periods may affect device reliability.

ELECTRICAL CHARACTERISTICS

Electrical Specifications: Unless otherwise specified, all limits are established for $V_{\text{LOGIC}} = 4.5\text{V}$ to 5.5V , $V_{\text{LOAD}} = 30\text{V}$, $V_{\text{REF}} = 5\text{V}$, $T_{\text{A}} = 25^\circ\text{C}$

Parameters	Sym	Min	Typ	Max	Units	Conditions
DC Characteristics						
Logic Supply Voltage	V_{LOGIC}	4.5	5.0	5.5	V	
Load Supply Voltage	V_{LOAD}	10	30	40	V	
Logic Supply Current	I_{VLOGIC}	—	0.8	1.0	mA	
V_{REF} Voltage Range	V_{REF}	1.5	5.0	7.0	V	
Driver Supply Current	$I_{\text{VLOAD_ON}}$	—	0.55	1.0	mA	Both Bridges ON, No Load
	$I_{\text{VLOAD_OFF}}$	—	0.55	1.0	mA	Both Bridges Off
Control Logic Input Current ($V_{\text{IN}} = 0\text{V}$)	I_{IN}	—	—	-70	μA	I01,I11,I02,I12,PHASE1,PHASE2, (Note 1)
Logic Low Input Voltage	V_{IL}	—	—	0.8	V	I01,I11,I02,I12,PHASE1,PHASE2
Logic High Input Voltage	V_{IH}	2.4	—	—	V	I01,I11,I02,I12,PHASE1,PHASE2
Current Limit Threshold Ratio ($V_{\text{REF}} \div V_{\text{SENSE}}$)	$V_{\text{REF_VSENS}}/E$	9.5	10	10.5	—	I0=L,I1=L
		13.5	15	16.5	—	I0=H,I1=L
		25.5	30	34.5	—	I0=L,I1=H
Driver Output Saturation Voltage $V_{\text{CE(SAT)}}$	V_{ONN} (Low Side)	—	0.55	0.65	V	(Sink) IOU = +500 mA
		—	0.90	1.00	V	(Sink) IOU = +750 mA
	V_{ONP} (High Side)	—	1.05	1.40	V	(Source) IOU = -500 mA
		—	1.85	2.10	V	(Source) IOU = -750 mA
Clamp Diode Forward Voltage (Note 2)	$V_{\text{F_NDIODE}}$	—	0.95	1.30	V	$I_{\text{F}} = 750\text{ mA}$
	$V_{\text{F_PDIODE}}$	—	1.00	1.30	V	$I_{\text{F}} = 750\text{ mA}$
Driver Output Leakage Current	I_{LEAK}	—	—	-50	μA	$V_{\text{OUT}} = 0\text{V}$
		—	—	50	μA	$V_{\text{OUT}} = V_{\text{LOAD}}$
Thermal Shutdown Temperature	$T_{\text{J_SHDN}}$	—	170	—	$^\circ\text{C}$	
AC Characteristics						
Cut-off Time (one-shot pulse)	T_{OFF}	—	50	58	μs	$R_{\text{S}}=1\Omega, R_{\text{C}}=1\text{k}\Omega, C_{\text{C}}=820\text{pF}, R_{\text{T}}=56\text{k}\Omega, C_{\text{T}}=820\text{pF}$
Turn-off Delay	T_{D}	—	1.5	10	μs	
			—	—		

Note 1: $V_{\text{IN}} = 5.0\text{V}$ input current given by internal pull-up to Logic Supply.

Note 2: Clamp/Freewheel diode is the intrinsic body-drain diode of the NMOS and PMOS transistors.

[查询MTS62C19A供应商](#)

TEMPERATURE SPECIFICATIONS

Parameters	Sym	Min	Typ	Max	Units	Conditions
Recommended Temperature Ranges						
Junction Temperature Range	T_J	-20		+125	°C	
Operating Temperature Range	T_A	-20		+70	°C	
Thermal Package Resistance						
Thermal Resistance, SOP-24	θ_{JA} θ_{JC}	— —	76 16	— —	°C/W	EIA/JEDEC JESD51-10

MTS62C19A

[查询MTS62C19A供应商](#)

2.0 PIN DESCRIPTIONS

The descriptions of the pins are listed in [Table 2-1](#).

TABLE 2-1: MTS62C19A PIN FUNCTION TABLE

Pin No. SOP-24	Type	Name	Function
1	Output	OUT1A	Output 1 'A' Side of Motor Winding
2	Output	OUT2A	Output 2 'A' Side of Motor Winding
3	Input	SENSE2	Current Sense for Output 2
4	Input	COMPIN2	Current Sense Comparator Input for Output 2
5	Output	OUT2B	Output 2 'B' Side of Motor Winding
6	Power	GND	Negative Logic Supply (Ground)
7	Power	GND	Negative Logic Supply (Ground)
8	Input	I02	Output 2 Current Selection Bit 0
9	Input	I12	Output 2 Current Selection Bit 1
10	Input	PHASE2	Output 2 Phase
11	Input	VREF2	Output 2 Current Reference
12	Input	RC2	Output 2 RC Time Constant
13	Power	VLOGIC	Positive Logic Supply Voltage
14	Input	RC1	Output 1 RC Time Constant
15	Input	VREF1	Output 1 Current Reference
16	Input	PHASE1	Output 1 Phase
17	Input	I11	Output 1 Current Selection Bit 1
18	Power	GND	Negative Logic Supply (Ground)
19	Power	GND	Negative Logic Supply (Ground)
20	Input	I01	Output 1 Current Selection Bit 0
21	Output	OUT1B	Output 1 'B' Side of Motor Winding
22	Input	COMPIN1	Current Sense Comparator Input for Output 1
23	Input	SENSE1	Current Sense for Output 1
24	Power	VLOAD	Positive Load Supply Voltage

2.1 Ground Terminal (GND)

Logic supply ground. Only the driver current flows out of this pin; there is no high current. Minimize voltage drops between this pin and the logic inputs.

2.2 Logic Supply Voltage (VLOGIC)

Connect VLOGIC to the logic source voltage. Decouple the supply with a 0.1 μ F ceramic capacitor mounted close to the VLOGIC and GND terminals.

2.3 Load Supply Voltage (VLOAD)

Connect VLOAD to the motor positive voltage supply. The motor current is supplied through this pin and the selected output transistors.

2.4 Current Detection Selection (I01, I02, I11, I12)

Comparator input for current threshold detection. The voltage across the sense resistor is fed back to this input through the low pass filter RcCc. The power transistors are disabled when the sense voltage exceeds the reference voltage of the selected comparator. When this occurs the current decays for a time set by RtCt ($T_{OFF} = 1.1 RtCt$).

[查询MTS62C19A供应商](#)

2.5 Current Flow Direction Selection (PHASE1, PHASE2)

Logic input to select the direction of current flow through the load. A "HIGH" logic signal level causes load current to flow from OUTxA to OUTxB. A "LOW" logic level causes load current to flow from OUTxB to OUTxA.

2.6 Current Sense Reference (VREF1, VREF2)

Reference voltage for current sense comparator. Determines the level of output current detection together with sensing resistor and inputs I0x, I1x.

2.7 Current Sense Input (SENSE1, SENSE2)

Connection to lower sources of output stage for insertion of current sense resistor.

2.8 Current Sense Comparator Input (COMPIN1, COMPIN2)

Current sense comparator input.

2.9 Output Stage OFF Time (RC1, RC2)

A parallel RtCt network connected to this pin sets the OFF time of the power transistors. The pulse generator is a monostable triggered by the output of the current sense comparator.

2.10 Output Stage (OUT1A, OUT2A, OUT1B, OUT2B)

Output connection to "A" side and "B" side of motor windings.

MTS62C19A

[查询MTS62C19A供应商](#)

3.0 FUNCTIONAL DESCRIPTION

The circuit is designed to drive the two windings of a bipolar stepper motor and can be divided in two identical channels (channel 1 and channel 2) and protection circuitry for over temperature and undervoltage. The functionality of a channel and protection circuitry is presented on next sections.

3.1 Power Bridge Operation

Each motor winding is driven by an H-type bridge consisting of two N and two P transistors that allow the current to flow in both winding directions depending on the value of the PHASE signal (Table 3-1). The H-bridge can be set in 5 configurations that are related to the digital inputs PHASE, I0 and I1 and to the current sensed. These configurations are given in Table 3-2.

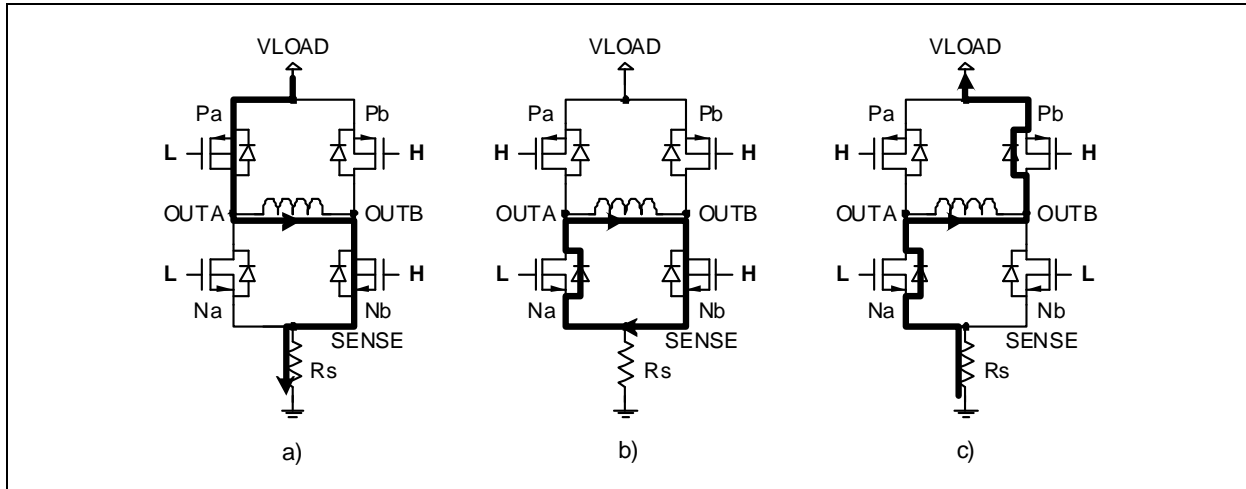

FIGURE 3-1: Power bridge control (PHASE = H / forward): (a) bridge ON, (b) source OFF, and (c) all OFF / coasting (for PHASE = L / reverse: invert A and B in drawings)

TABLE 3-1: CURRENT DIRECTION CONTROL

Phase	Output Current
L	Current flows from OUTxB to OUTxA
H	Current flows from OUTxA to OUTxB

TABLE 3-2: POWER BRIDGE GATE CONTROL TRUTH TABLE

I0I1	PHASE	overi	T _{OFF}	Case/Mode	gna	gpa	gnb	gpb
00/01/10	1	0	0	Forward ON	L	L	H	H
00/01/10	1	x	1	Forward OFF	L	H	H	H
00/01/10	0	0	0	Reverse ON	H	H	L	L
00/01/10	0	x	1	Reverse OFF	H	H	L	H
11	x	x	x	No Current/ Coasting	L	H	L	H

Legend: Bold = Active MOS Transistors, Overi = Overcurrent flag, T_{OFF} = Channel T_{OFF} State Flag

3.2 PWM Current Control

The current level in each motor winding is controlled by a PWM circuit with a fixed T_{OFF} time. The load current flowing in the winding is sensed through an external sensing resistor R_s connected between the power bridge's source pin SENSE (sources of transistors Na and Nb) and GND.

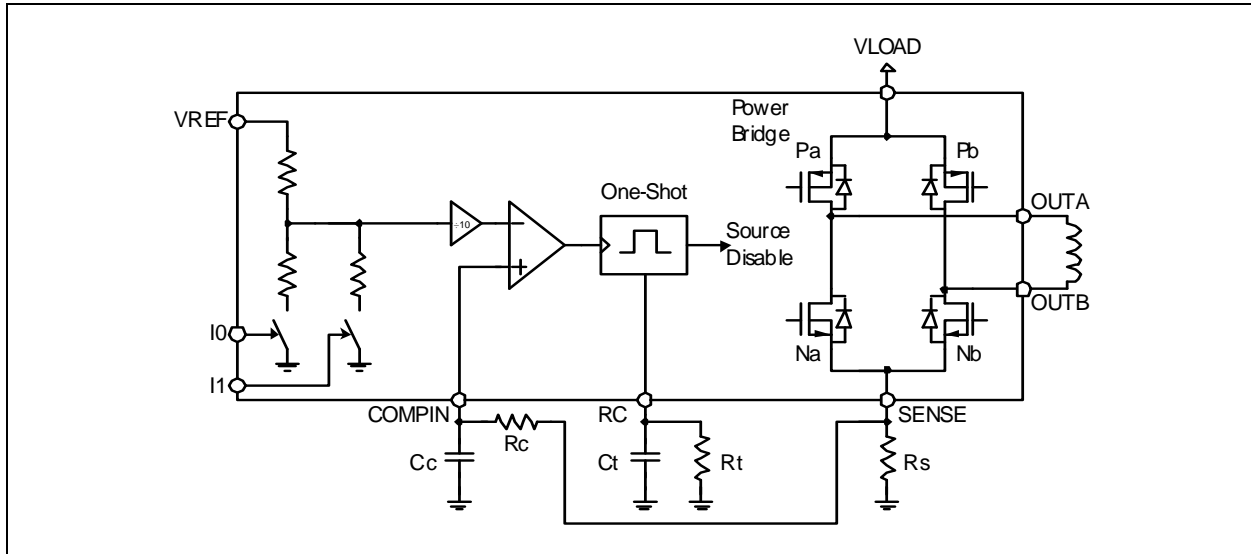

FIGURE 3-2: PWM Current Control Circuit Principle (Channel 1 Shown)

The voltage across R_s is compared to a fraction of the reference voltage VREF, chosen with the logic input bits I0 and I1 (Table 3-3). The power bridge and thus the load current can also be switched off completely when both logic inputs are high. Note that any logic input left unconnected will be treated as a high level (pull-up resistor).

EQUATION 3-1:

$$I_{MAX} = \frac{V_{REF}}{10 * R_s}$$

The maximum trip current for regulation, given for I0 I1 = 00 is calculated in Equation 3-1.

TABLE 3-3: CURRENT LEVEL CONTROL TRUTH TABLE

I0	I1	Comp. Trip Voltage	Output Current
0	0	Vtrip = 1/10*Vref	I _{max} = Vref/10RS
1	0	Vtrip = 1/15*Vref	2/3*I _{max} = Vref/15RS
0	1	Vtrip = 1/30*Vref	1/3*I _{max} = Vref/30RS
1	1	x	0 (no current)

When the maximum allowed current is reached, the bridge source is turned off during a fixed period T_{OFF} (typically 50us) given by a non-retriggerable pulse generator and the external timing components Rt (20k-100 kΩ range) and Ct (100 pF-1000 pF range):

$$t_{off} = 1.1 * (Rt * Ct)$$

During T_{OFF} the winding current decreases. When the driver is re-enabled, the winding current increases again until it reaches the threshold, and the cycle repeats itself maintaining the load current at the desired level.

MTS62C19A

[查询MTS62C19A供应商](#)

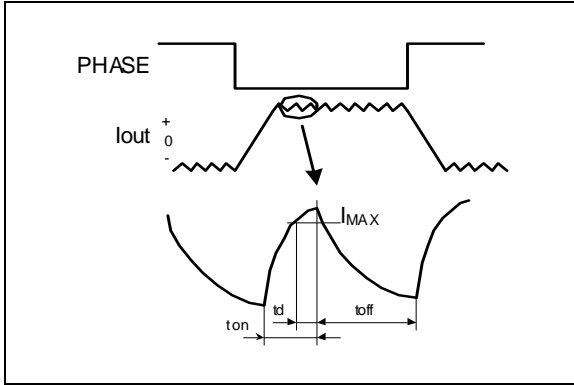

FIGURE 3-3: PWM Output Current Waveform

3.3 Circuit Protection

A thermal protection circuitry turns off all drivers when the junction temperature exceeds a safe operating limit of 170°C (typ.). This protects the devices from failure due to excessive heating. Despite this thermal protection, output short circuits are not permitted. The output drivers are re-enabled once junction temperature has dropped below 145°C (typ.).

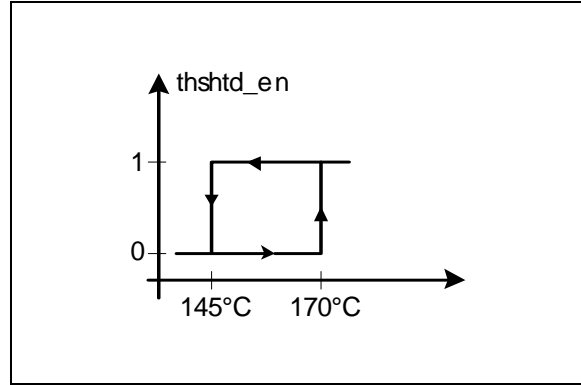

FIGURE 3-4: Thermal Shutdown Output vs. Temperature Showing Hysteresis

An undervoltage lockout circuit protects the MTS62C19A from potential shoot-through currents when the load supply voltage is applied prior to the logic supply voltage. The power bridge and all outputs are disabled if VLOGIC is smaller than 4V.

With this protection feature, the circuit will withstand any order of turn-on or turn-off of the supply voltages VLOGIC and VLOAD. Normal dV/dt values are assumed.

4.0 APPLICATION CIRCUITS & ISSUES

4.1 Typical Application

The MTS62C19A circuit with external components for a typical application is shown in Figure 4-1. Typical passive component values are: $R_s = 1\Omega$, $R_c = 1k\Omega$, $C_c = 820pF$, $R_t = 56k\Omega$ and $C_t = 820pF$.

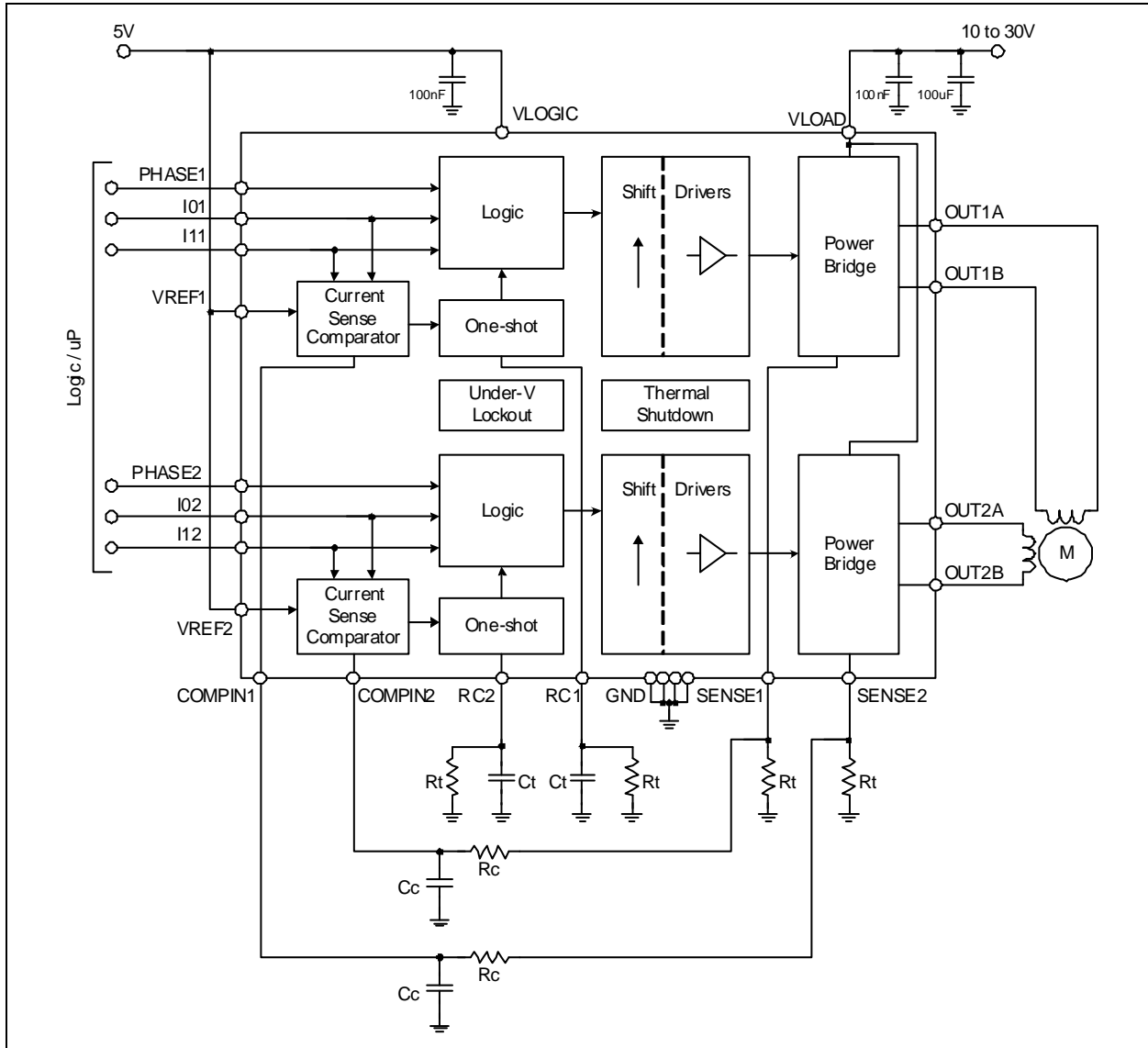

FIGURE 4-1: Typical Application Circuit

During PWM operation, when the output stage is turned-on, large voltage peaks might appear across R_s , which can wrongly trigger the input comparator. To avoid an unstable current control, an external $R_c C_c$ filter should be used that delays the comparator action. Depending on load type many applications will not require this filter (SENSE connected to COMPIN).

MTS62C19A

[查询MTS62C19A供应商](#)

4.2 Stepping Examples

The MTS62C19A allows to control a motor in full-step, half-step, modified half-step and microstepping mode, as shown in Figure 4-2.

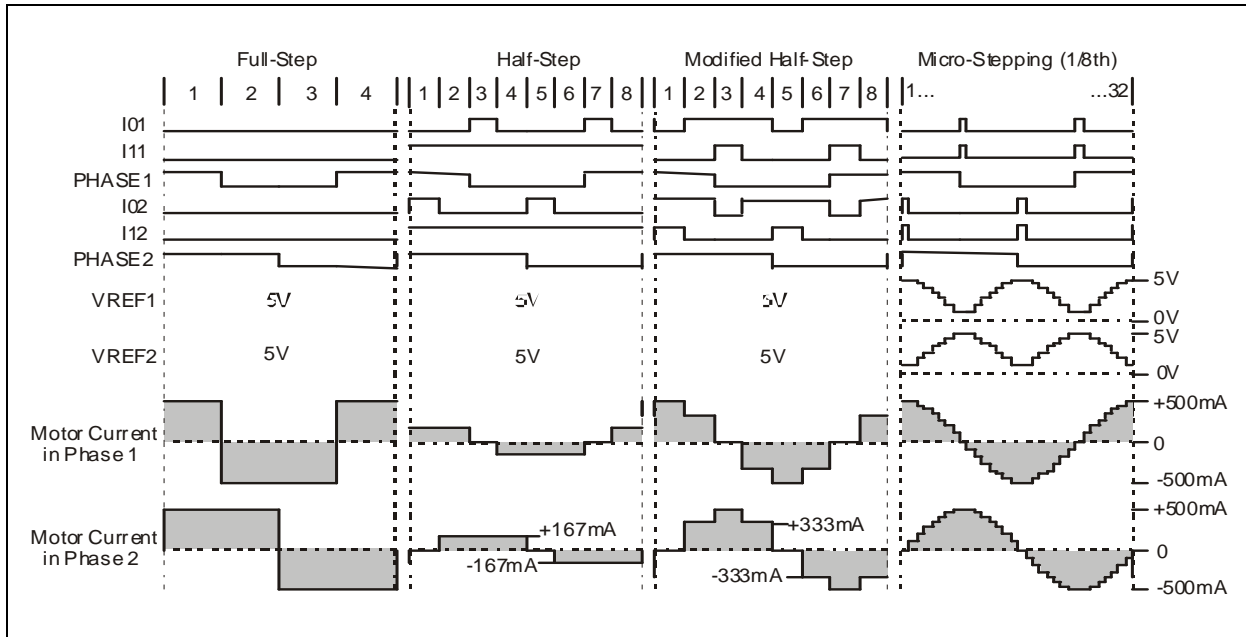

FIGURE 4-2: Examples of Stepping Modes Achievable with Typical Application Circuit

4.3 PCB Design Guidelines

Unused inputs should be connected to fixed voltage levels in order to get the highest noise immunity. Typical PCB layout guidelines for power application should be followed. These include separate power ground planes, supply decoupling capacitors close to the IC, short connections and use of maximized copper areas to improve thermal dissipation.

5.0 MECHANICAL DIMENSIONS

SOP 24L Package Outline

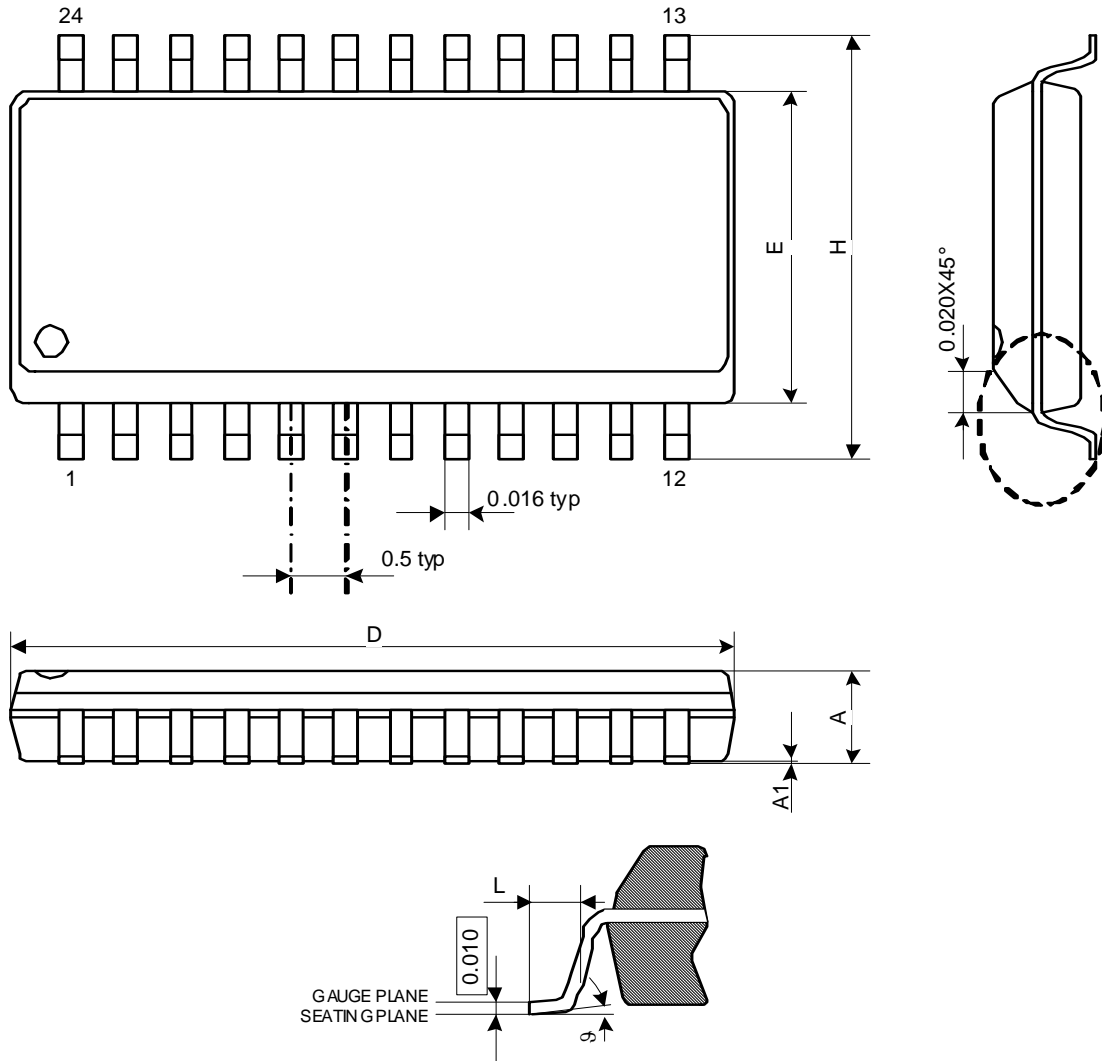

Symbol	Minimum	Typical	Maximum	Unit
A	—	—	2.642 (0.104)	mm (inch)
A1	0.102 (0.004)	—	—	mm (inch)
D	15.545 (0.612)	15.697 (0.618)	15.850 (0.624)	mm (inch)
E	7.417 (0.292)	7.518 (0.296)	7.595 (0.299)	mm (inch)
H	10.287 (0.405)	10.464 (0.412)	10.643 (0.419)	mm (inch)
L	0.533 (0.021)	0.787 (0.031)	1.041 (0.041)	mm (inch)
J	0	4	8	°

Note 1: JEDEC outline: M0-119 AA

- Dimensions "D" does not include mold flash, protrusions or gate burrs. Mold flash, protrusions and gate burrs should not exceed 0.25mm (0.010inch) per side.
- Dimensions "E" does not include inter-lead flash, or protrusions. Inter-lead flash and protrusions shall not exceed 0.25mm (0.010 inch) per side.

MTS62C19A

[查询MTS62C19A供应商](#)

NOTES:

[查询MTS62C19A供应商](#)

APPENDIX A: REVISION HISTORY

Revision A (September 2010)

- Original Release of this Document.

MTS62C19A

[查询MTS62C19A供应商](#)

NOTES:

Note the following details of the code protection feature on Microchip devices:

- Microchip products meet the specification contained in their particular Microchip Data Sheet.
- Microchip believes that its family of products is one of the most secure families of its kind on the market today, when used in the intended manner and under normal conditions.
- There are dishonest and possibly illegal methods used to breach the code protection feature. All of these methods, to our knowledge, require using the Microchip products in a manner outside the operating specifications contained in Microchip's Data Sheets. Most likely, the person doing so is engaged in theft of intellectual property.
- Microchip is willing to work with the customer who is concerned about the integrity of their code.
- Neither Microchip nor any other semiconductor manufacturer can guarantee the security of their code. Code protection does not mean that we are guaranteeing the product as “unbreakable.”

Code protection is constantly evolving. We at Microchip are committed to continuously improving the code protection features of our products. Attempts to break Microchip's code protection feature may be a violation of the Digital Millennium Copyright Act. If such acts allow unauthorized access to your software or other copyrighted work, you may have a right to sue for relief under that Act.

Information contained in this publication regarding device applications and the like is provided only for your convenience and may be superseded by updates. It is your responsibility to ensure that your application meets with your specifications. MICROCHIP MAKES NO REPRESENTATIONS OR WARRANTIES OF ANY KIND WHETHER EXPRESS OR IMPLIED, WRITTEN OR ORAL, STATUTORY OR OTHERWISE, RELATED TO THE INFORMATION, INCLUDING BUT NOT LIMITED TO ITS CONDITION, QUALITY, PERFORMANCE, MERCHANTABILITY OR FITNESS FOR PURPOSE. Microchip disclaims all liability arising from this information and its use. Use of Microchip devices in life support and/or safety applications is entirely at the buyer's risk, and the buyer agrees to defend, indemnify and hold harmless Microchip from any and all damages, claims, suits, or expenses resulting from such use. No licenses are conveyed, implicitly or otherwise, under any Microchip intellectual property rights.

Trademarks

The Microchip name and logo, the Microchip logo, dsPIC, KEELOQ, KEELOQ logo, MPLAB, PIC, PICmicro, PICSTART, PIC³² logo, rPIC and UNI/O are registered trademarks of Microchip Technology Incorporated in the U.S.A. and other countries.

FilterLab, Hampshire, HI-TECH C, Linear Active Thermistor, MXDEV, MXLAB, SEEVAL and The Embedded Control Solutions Company are registered trademarks of Microchip Technology Incorporated in the U.S.A.

Analog-for-the-Digital Age, Application Maestro, CodeGuard, dsPICDEM, dsPICDEM.net, dsPICworks, dsSPEAK, ECAN, ECONOMONITOR, FanSense, HI-TIDE, In-Circuit Serial Programming, ICSP, Mindi, MiWi, MPASM, MPLAB Certified logo, MPLIB, MPLINK, mTouch, Omniscient Code Generation, PICC, PICC-18, PICDEM, PICDEM.net, PICkit, PICTail, REAL ICE, rLAB, Select Mode, Total Endurance, TSHARC, UniWinDriver, WiperLock and ZENA are trademarks of Microchip Technology Incorporated in the U.S.A. and other countries.

SQTP is a service mark of Microchip Technology Incorporated in the U.S.A.

All other trademarks mentioned herein are property of their respective companies.

© 2010, Microchip Technology Incorporated, Printed in the U.S.A., All Rights Reserved.

 Printed on recycled paper.

ISBN: 978-1-60932-535-0

Microchip received ISO/TS-16949:2002 certification for its worldwide headquarters, design and wafer fabrication facilities in Chandler and Tempe, Arizona; Gresham, Oregon and design centers in California and India. The Company's quality system processes and procedures are for its PIC® MCUs and dsPIC® DSCs, KEELOQ® code hopping devices, Serial EEPROMs, microperipherals, nonvolatile memory and analog products. In addition, Microchip's quality system for the design and manufacture of development systems is ISO 9001:2000 certified.

**QUALITY MANAGEMENT SYSTEM
CERTIFIED BY DNV
== ISO/TS 16949:2002 ==**

Worldwide Sales and Service

AMERICAS

Corporate Office
2355 West Chandler Blvd.
Chandler, AZ 85224-6199
Tel: 480-792-7200
Fax: 480-792-7277
Technical Support:
<http://support.microchip.com>
Web Address:
www.microchip.com

Atlanta
Duluth, GA
Tel: 678-957-9614
Fax: 678-957-1455

Boston
Westborough, MA
Tel: 774-760-0087
Fax: 774-760-0088

Chicago
Itasca, IL
Tel: 630-285-0071
Fax: 630-285-0075

Cleveland
Independence, OH
Tel: 216-447-0464
Fax: 216-447-0643

Dallas
Addison, TX
Tel: 972-818-7423
Fax: 972-818-2924

Detroit
Farmington Hills, MI
Tel: 248-538-2250
Fax: 248-538-2260

Kokomo
Kokomo, IN
Tel: 765-864-8360
Fax: 765-864-8387

Los Angeles
Mission Viejo, CA
Tel: 949-462-9523
Fax: 949-462-9608

Santa Clara
Santa Clara, CA
Tel: 408-961-6444
Fax: 408-961-6445

Toronto
Mississauga, Ontario,
Canada
Tel: 905-673-0699
Fax: 905-673-6509

ASIA/PACIFIC

Asia Pacific Office
Suites 3707-14, 37th Floor
Tower 6, The Gateway
Harbour City, Kowloon
Hong Kong
Tel: 852-2401-1200
Fax: 852-2401-3431

Australia - Sydney
Tel: 61-2-9868-6733
Fax: 61-2-9868-6755

China - Beijing
Tel: 86-10-8528-2100
Fax: 86-10-8528-2104

China - Chengdu
Tel: 86-28-8665-5511
Fax: 86-28-8665-7889

China - Chongqing
Tel: 86-23-8980-9588
Fax: 86-23-8980-9500

China - Hong Kong SAR
Tel: 852-2401-1200
Fax: 852-2401-3431

China - Nanjing
Tel: 86-25-8473-2460
Fax: 86-25-8473-2470

China - Qingdao
Tel: 86-532-8502-7355
Fax: 86-532-8502-7205

China - Shanghai
Tel: 86-21-5407-5533
Fax: 86-21-5407-5066

China - Shenyang
Tel: 86-24-2334-2829
Fax: 86-24-2334-2393

China - Shenzhen
Tel: 86-755-8203-2660
Fax: 86-755-8203-1760

China - Wuhan
Tel: 86-27-5980-5300
Fax: 86-27-5980-5118

China - Xian
Tel: 86-29-8833-7252
Fax: 86-29-8833-7256

China - Xiamen
Tel: 86-592-2388138
Fax: 86-592-2388130

China - Zhuhai
Tel: 86-756-3210040
Fax: 86-756-3210049

ASIA/PACIFIC

India - Bangalore
Tel: 91-80-3090-4444
Fax: 91-80-3090-4123

India - New Delhi
Tel: 91-11-4160-8631
Fax: 91-11-4160-8632

India - Pune
Tel: 91-20-2566-1512
Fax: 91-20-2566-1513

Japan - Yokohama
Tel: 81-45-471- 6166
Fax: 81-45-471-6122

Korea - Daegu
Tel: 82-53-744-4301
Fax: 82-53-744-4302

Korea - Seoul
Tel: 82-2-554-7200
Fax: 82-2-558-5932 or
82-2-558-5934

Malaysia - Kuala Lumpur
Tel: 60-3-6201-9857
Fax: 60-3-6201-9859

Malaysia - Penang
Tel: 60-4-227-8870
Fax: 60-4-227-4068

Philippines - Manila
Tel: 63-2-634-9065
Fax: 63-2-634-9069

Singapore
Tel: 65-6334-8870
Fax: 65-6334-8850

Taiwan - Hsin Chu
Tel: 886-3-6578-300
Fax: 886-3-6578-370

Taiwan - Kaohsiung
Tel: 886-7-213-7830
Fax: 886-7-330-9305

Taiwan - Taipei
Tel: 886-2-2500-6610
Fax: 886-2-2508-0102

Thailand - Bangkok
Tel: 66-2-694-1351
Fax: 66-2-694-1350

EUROPE

Austria - Wels
Tel: 43-7242-2244-39
Fax: 43-7242-2244-393

Denmark - Copenhagen
Tel: 45-4450-2828
Fax: 45-4485-2829

France - Paris
Tel: 33-1-69-53-63-20
Fax: 33-1-69-30-90-79

Germany - Munich
Tel: 49-89-627-144-0
Fax: 49-89-627-144-44

Italy - Milan
Tel: 39-0331-742611
Fax: 39-0331-466781

Netherlands - Drunen
Tel: 31-416-690399
Fax: 31-416-690340

Spain - Madrid
Tel: 34-91-708-08-90
Fax: 34-91-708-08-91

UK - Wokingham
Tel: 44-118-921-5869
Fax: 44-118-921-5820