



PCF8532

Universal LCD driver for low multiplex rates

Rev. 1 — 10 February 2009

Product data sheet

1. General description

The PCF8532 is a peripheral device which interfaces to almost any Liquid Crystal Display (LCD) with low multiplex rates. It generates the drive signals for any static or multiplexed LCD containing up to four backplanes and up to 160 segments and can easily be cascaded for larger LCD applications. The PCF8532 is compatible with most microprocessors or microcontrollers and communicates via a two-line bidirectional I²C-bus. Communication overheads are minimized by a display RAM with auto-incremental addressing, by hardware subaddressing and by display memory switching (static and duplex drive modes).

2. Features

- Single-chip LCD controller and driver for up to 640 elements
- Selectable backplane drive configuration: static or 2, 3 or 4 backplane multiplexing
- 160 segment drives:
 - ◆ Up to 80 7-segment numeric characters
 - ◆ Up to 42 14-segment alphanumeric characters
 - ◆ Any graphics of up to 640 elements
- May be cascaded for large LCD applications (up to 2560 elements possible)
- 160 × 4-bit RAM for display data storage
- Software programmable frame frequency in steps of 5 Hz in the range of 60 Hz to 90 Hz
- Wide LCD supply range: from 2.5 V for low threshold LCDs and up to 8.0 V for guest-host LCDs and high threshold (automobile) twisted nematic LCDs
- Internal LCD bias generation with voltage-follower buffers
- Selectable display bias configuration: static, 1/2 or 1/3
- Wide power supply range: from 1.8 V to 5.5 V
- LCD and logic supplies may be separated
- Low power consumption, typically: I_{DD} = 4 μA, I_{DD(LCD)} = 40 μA
- 400 kHz I²C-bus interface
- Auto-incremental display data loading across device subaddress boundaries
- Versatile blinking modes
- Compatible with Chip-On-Glass (COG) technology
- Display memory bank switching in static and duplex drive modes
- No external components
- Manufactured in silicon gate CMOS process
- Two sets of backplane outputs for optimal COG configurations of the application

3. Ordering information

Table 1. Ordering information

Type number	Package		
	Name	Description	Version
PCF8532U/2DA/1	PCF8532U	bare die; 197 bumps; 6.5 × 1.16 × 0.38 mm ^[1]	PCF8532U

[1] Chip with bumps in tray.

4. Marking

Table 2. Marking codes

Type number	Marking code
PCF8532U/2DA/1	PC8532-1

5. Block diagram

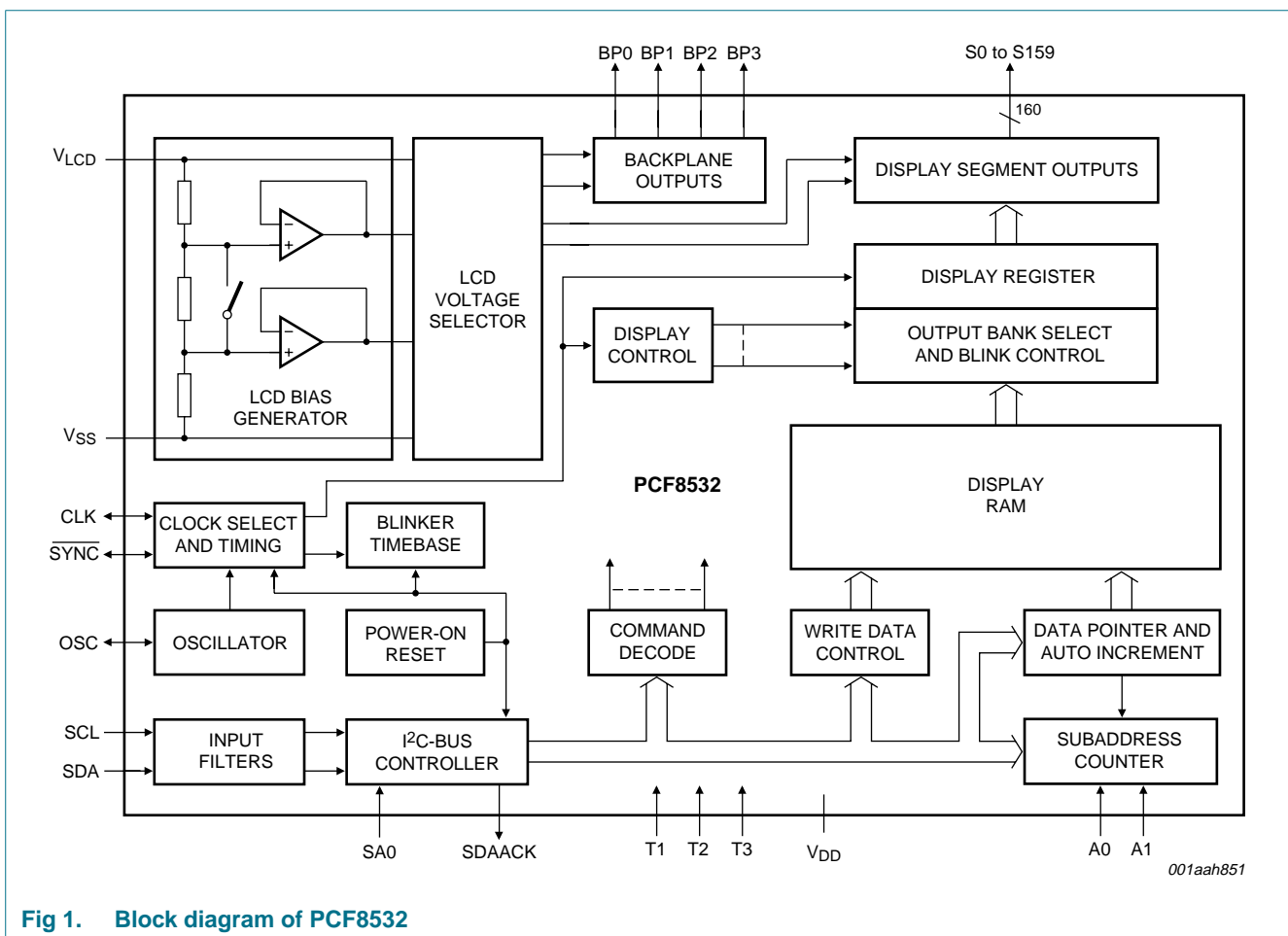
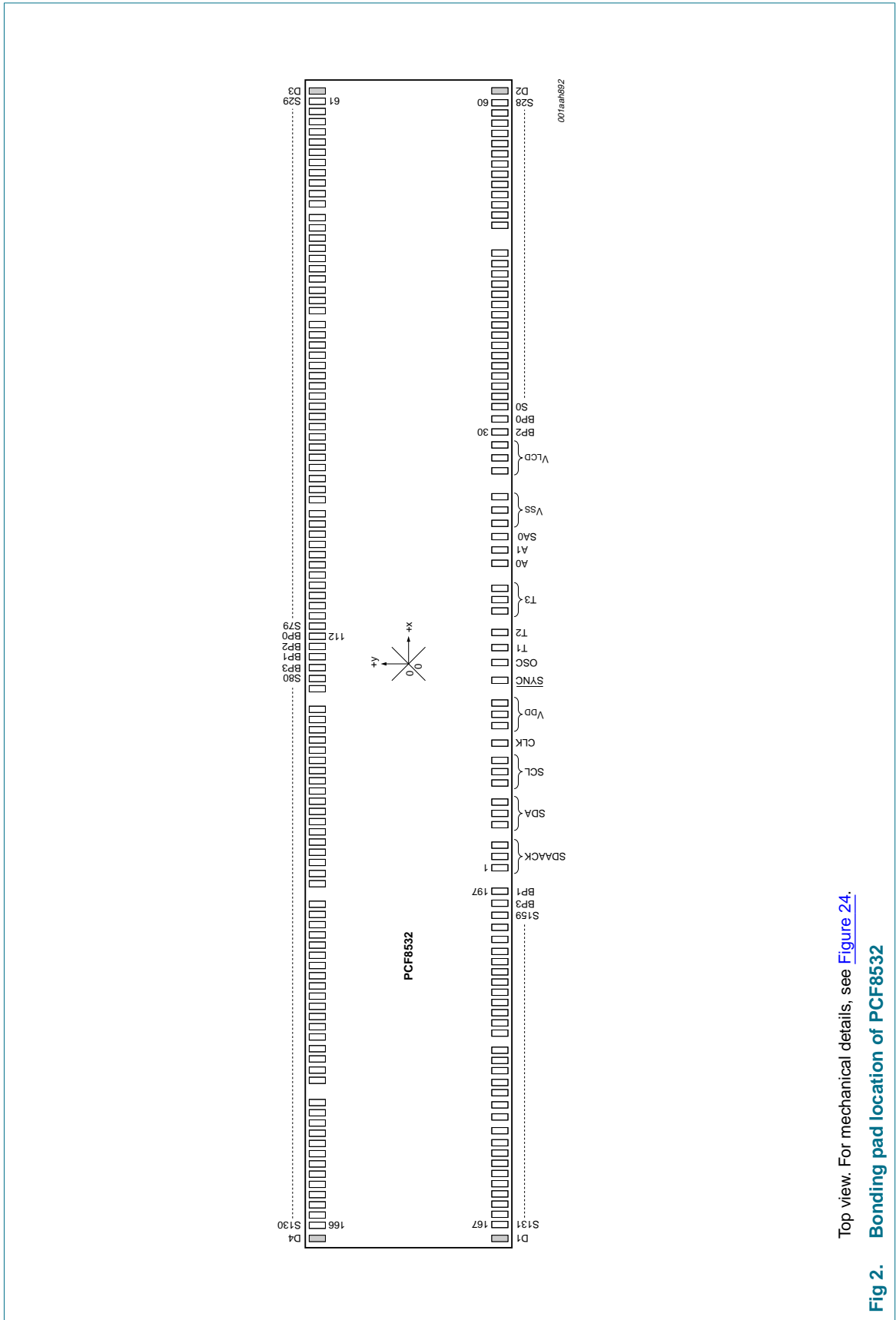

Fig 1. Block diagram of PCF8532

6. Pinning information

6.1 Pinning



Top view. For mechanical details, see [Figure 24](#).

Fig 2. Bonding pad location of PCF8532

6.2 Pin description

Table 3. Pin description

Symbol	Pin		Description
SDAACK	1 to 3	[1]	I ² C-bus acknowledge output
SDA	4 to 6	[1]	I ² C-bus serial data input
SCL	7 to 9		I ² C-bus serial clock input
CLK	10		clock input/output
V _{DD}	11 to 13		supply voltage
SYN ^C	14		cascade synchronization input/output
OSC	15		selection of internal or external clock
T1, T2 and T3	16, 17 and 18 to 20		dedicated testing pins; to be tied to V _{SS} in application mode
A0 and A1	21, 22		subaddress inputs
SA0	23		I ² C-bus slave address input
V _{SS}	24 to 26	[2]	logic ground
V _{LCD}	27 to 29		LCD supply voltage
BP2 and BP0	30, 31		LCD backplane outputs
S0 to S79	32 to 111		LCD segment outputs
BP0, BP2, BP1 and BP3	112 to 115		LCD backplane outputs
S80 to S159	116 to 195		LCD segment outputs
BP3 and BP1	196, 197		LCD backplane outputs

[1] In most applications SDA and SDAACK can be tied together.

[2] The substrate (rear side of the die) is wired to V_{SS} but should not be electrically connected.

7. Functional description

The PCF8532 is a versatile peripheral device designed to interface any microprocessor or microcontroller to a wide variety of LCDs. It can directly drive any static or multiplexed LCD containing up to four backplanes and up to 160 segments.

The display configurations possible with the PCF8532 depend on the number of active backplane outputs required. A selection of display configurations is shown in [Table 4](#).

All of the display configurations can be implemented in a typical system as shown in [Figure 3](#).

Table 4. Possible display configurations

Number of		7-segment numeric		14-segment numeric		Dot matrix
Backplanes	Elements	Digits	Indicator symbols	Characters	Indicator symbols	
4	640	80	80	40	80	640 dots (4 × 160)
3	480	60	60	32	32	480 dots (3 × 160)
2	320	40	40	20	40	320 dots (2 × 160)
1	160	20	20	10	20	160 dots (1 × 160)

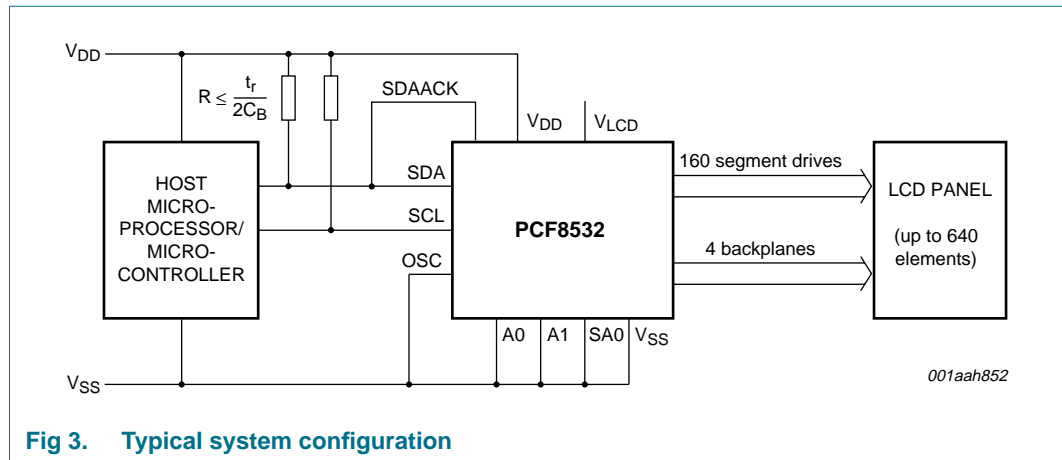

Fig 3. Typical system configuration

The host microprocessor or microcontroller maintains the 2-line I²C-bus communication channel with the PCF8532.

Biasing voltages for the multiplexed LCD waveforms are generated internally, removing the need for an external bias generator. The internal oscillator is selected by connecting pin OSC to V_{SS}. The only other connections required to complete the system are the power supplies (V_{DD}, V_{SS} and V_{LCD}) and the LCD panel selected for the application.

7.1 Power-on reset

At power-on the PCF8532 resets to a default starting condition:

- All backplane and segment outputs are set to V_{LCD}
- The selected drive mode is 1:4 multiplex with 1/3 bias
- Blinking is switched off
- Input and output bank selectors are reset
- The I²C-bus interface is initialized
- The data pointer and the subaddress counter are cleared (set to logic 0)
- The display is disabled
- If internal oscillator is selected (OSC pin connected to V_{SS}), then there is no clock signal on pin CLK

Do not transfer data on the I²C-bus after a power-on for at least 1 ms to allow the reset action to complete.

7.2 LCD bias generator

Fractional LCD biasing voltages are obtained from an internal voltage divider of three series resistors connected between V_{LCD} and V_{SS}. The center resistor can be switched out of the circuit to provide a 1/2 bias voltage level for the 1:2 multiplex configuration.

7.3 LCD voltage selector

The LCD voltage selector coordinates the multiplexing of the LCD in accordance with the selected LCD drive configuration. The operation of the voltage selector is controlled by mode-set commands from the command decoder. The biasing configurations that apply to the preferred modes of operation, together with the biasing characteristics as functions of V_{LCD} and the resulting discrimination ratios (D), are given in [Table 5](#).

Table 5. Preferred LCD drive modes: summary of characteristics

LCD drive mode	Number of:		LCD bias configuration	$\frac{V_{off(RMS)}}{V_{LCD}}$	$\frac{V_{on(RMS)}}{V_{LCD}}$	$D = \frac{V_{on(RMS)}}{V_{off(RMS)}}$
	Backplanes	Bias levels				
static	1	2	static	0	1	∞
1:2 multiplex	2	3	$\frac{1}{2}$	0.354	0.791	2.236
1:2 multiplex	2	4	$\frac{1}{3}$	0.333	0.745	2.236
1:3 multiplex	3	4	$\frac{1}{3}$	0.333	0.638	1.915
1:4 multiplex	4	4	$\frac{1}{3}$	0.333	0.577	1.732

A practical value for V_{LCD} is determined by equating $V_{off(RMS)}$ with a defined LCD threshold voltage (V_{th}), typically when the LCD exhibits approximately 10 % contrast. In the static drive mode a suitable choice is $V_{LCD} > 3V_{th}$.

Multiplex drive modes of 1:3 and 1:4 with $\frac{1}{2}$ bias are possible but the discrimination and hence the contrast ratios are smaller.

Bias is calculated by $\frac{1}{1+a}$, where the values for a are

$$a = 1 \text{ for } \frac{1}{2} \text{ bias}$$

$$a = 2 \text{ for } \frac{1}{3} \text{ bias}$$

The RMS on-state voltage ($V_{on(RMS)}$) for the LCD is calculated with the equation

$$V_{on(RMS)} = V_{LCD} \sqrt{\frac{\frac{1}{n} + \left[(n-1) \times \left(\frac{1}{1+a} \right) \right]^2}{n}} \quad (1)$$

where V_{LCD} is the resultant voltage at the LCD segment and where the values for n are

$$n = 1 \text{ for static mode}$$

$$n = 2 \text{ for 1:2 multiplex}$$

$$n = 3 \text{ for 1:3 multiplex}$$

$$n = 4 \text{ for 1:4 multiplex}$$

The RMS off-state voltage ($V_{off(RMS)}$) for the LCD is calculated with the equation:

$$V_{off(RMS)} = V_{LCD} \sqrt{\frac{a^2 - (2a+n)}{n \times (1+a)^2}} \quad (2)$$

Discrimination is the ratio of $V_{on(RMS)}$ to $V_{off(RMS)}$ and is determined from the equation:

$$\frac{V_{on(RMS)}}{V_{off(RMS)}} = \sqrt{\frac{(a+1)^2 + (n-1)}{(a-1)^2 + (n-1)}} \quad (3)$$

Using [Equation 3](#), the discrimination for an LCD drive mode of

- 1:3 multiplex with $\frac{1}{2}$ bias is $\sqrt{3} = 1.732$
- 1:4 multiplex with $\frac{1}{2}$ bias is $\frac{\sqrt{21}}{3} = 1.528$

The advantage of these LCD drive modes is a reduction of the LCD full scale voltage V_{LCD} as follows:

- 1:3 multiplex ($\frac{1}{2}$ bias): $V_{LCD} = \sqrt{6} \times V_{off(RMS)} = 2.449V_{off(RMS)}$
- 1:4 multiplex ($\frac{1}{2}$ bias): $V_{LCD} = \left[\frac{4 \times \sqrt{3}}{3} \right] = 2.309V_{off(RMS)}$

These compare with $V_{LCD} = 3V_{off(RMS)}$ when $\frac{1}{3}$ bias is used.

It should be noted that V_{LCD} is sometimes referred as the LCD operating voltage.

7.4 LCD drive mode waveforms

7.4.1 Static drive mode

The static LCD drive mode is used when a single backplane is provided in the LCD. Backplane and segment drive waveforms for this mode are shown in [Figure 4](#).

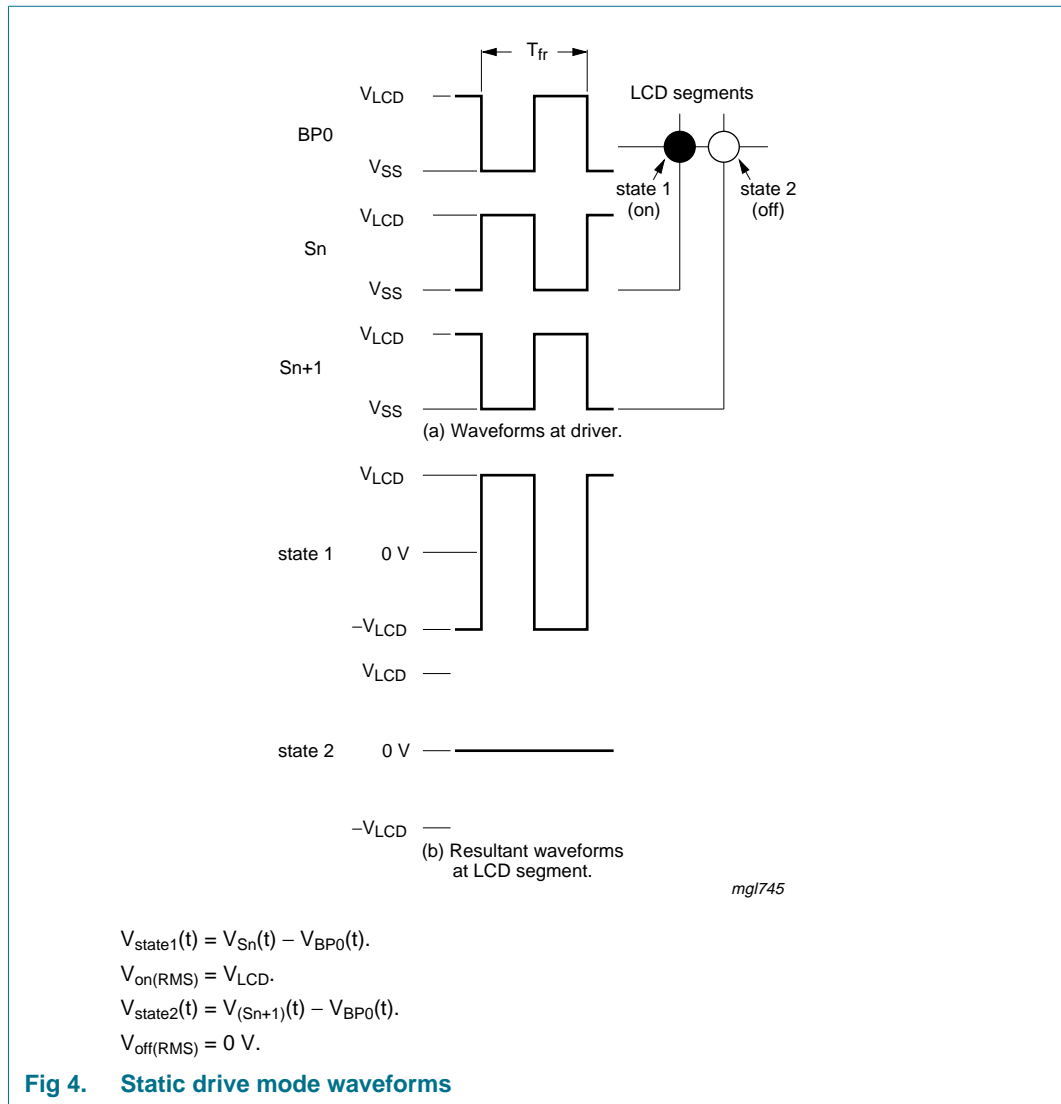

Fig 4. Static drive mode waveforms

7.4.2 1:2 multiplex drive mode

When two backplanes are provided in the LCD, the 1:2 multiplex mode applies. The PCF8532 allows the use of 1/2 bias or 1/3 bias in this mode as shown in Figure 5 and Figure 6.

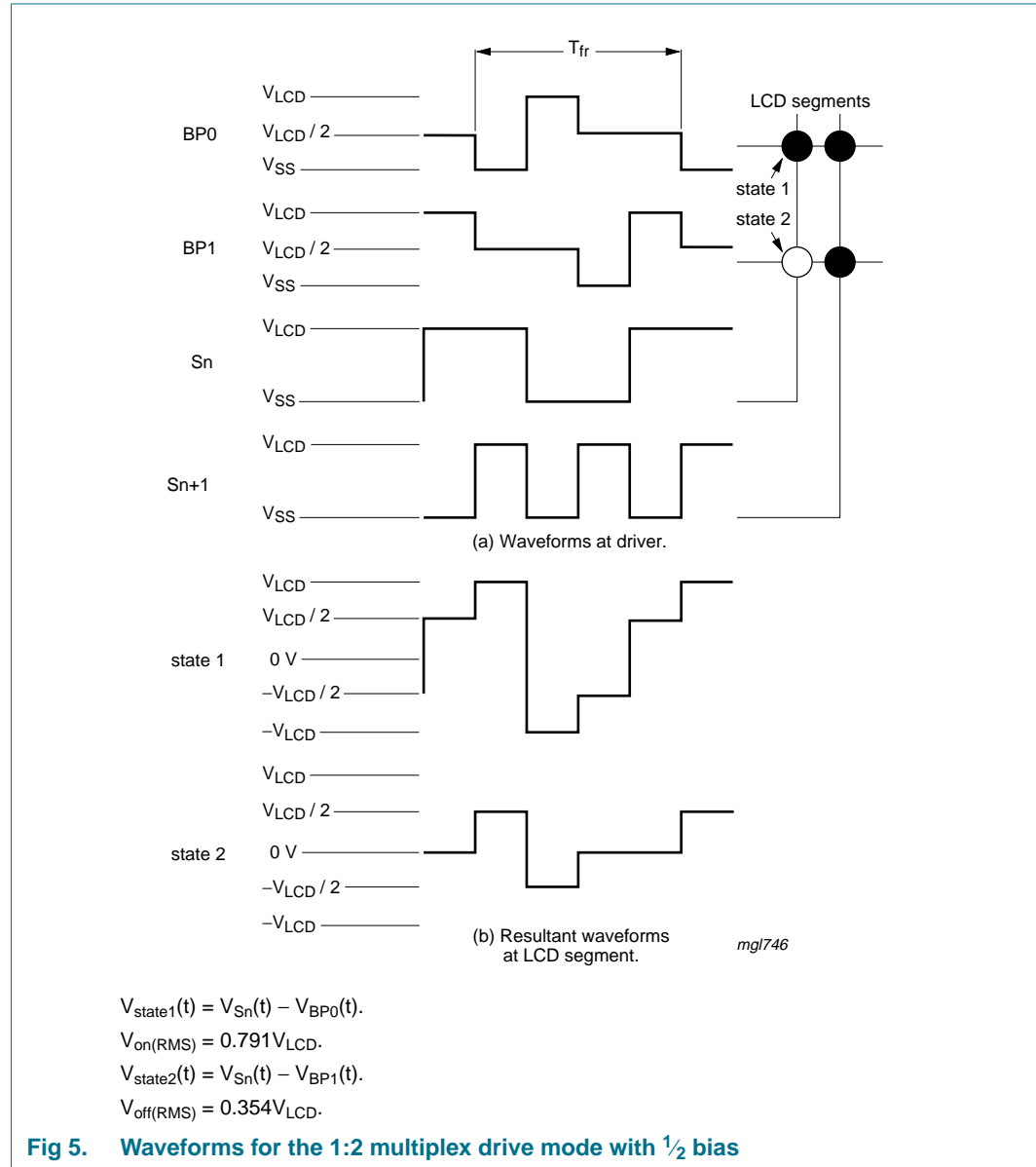
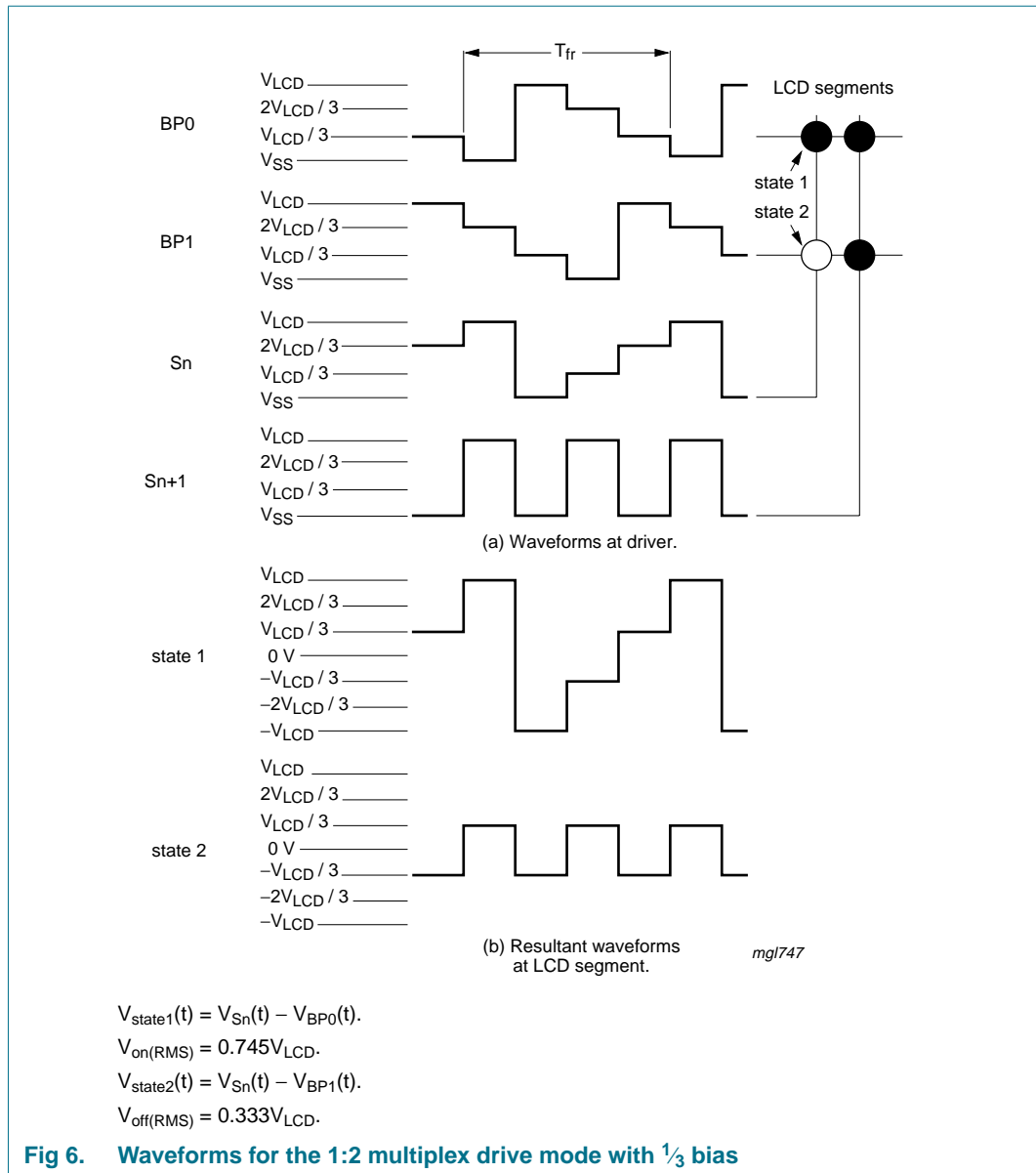
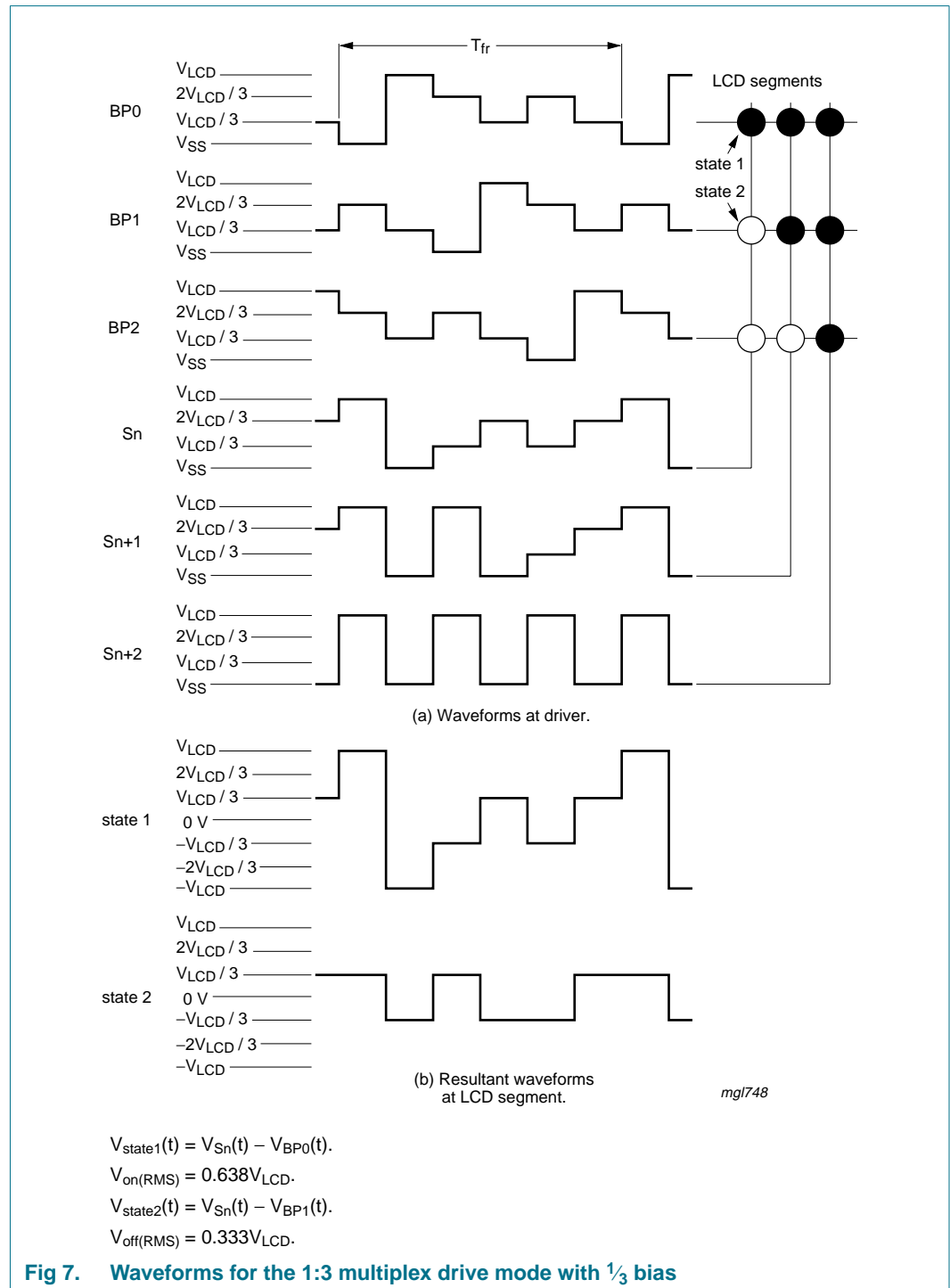

Fig 5. Waveforms for the 1:2 multiplex drive mode with 1/2 bias



7.4.3 1:3 multiplex drive mode

When three backplanes are provided in the LCD, the 1:3 multiplex drive mode applies as shown in [Figure 7](#).



7.4.4 1:4 multiplex drive mode

When four backplanes are provided in the LCD, the 1:4 multiplex drive mode applies as shown in Figure 8.

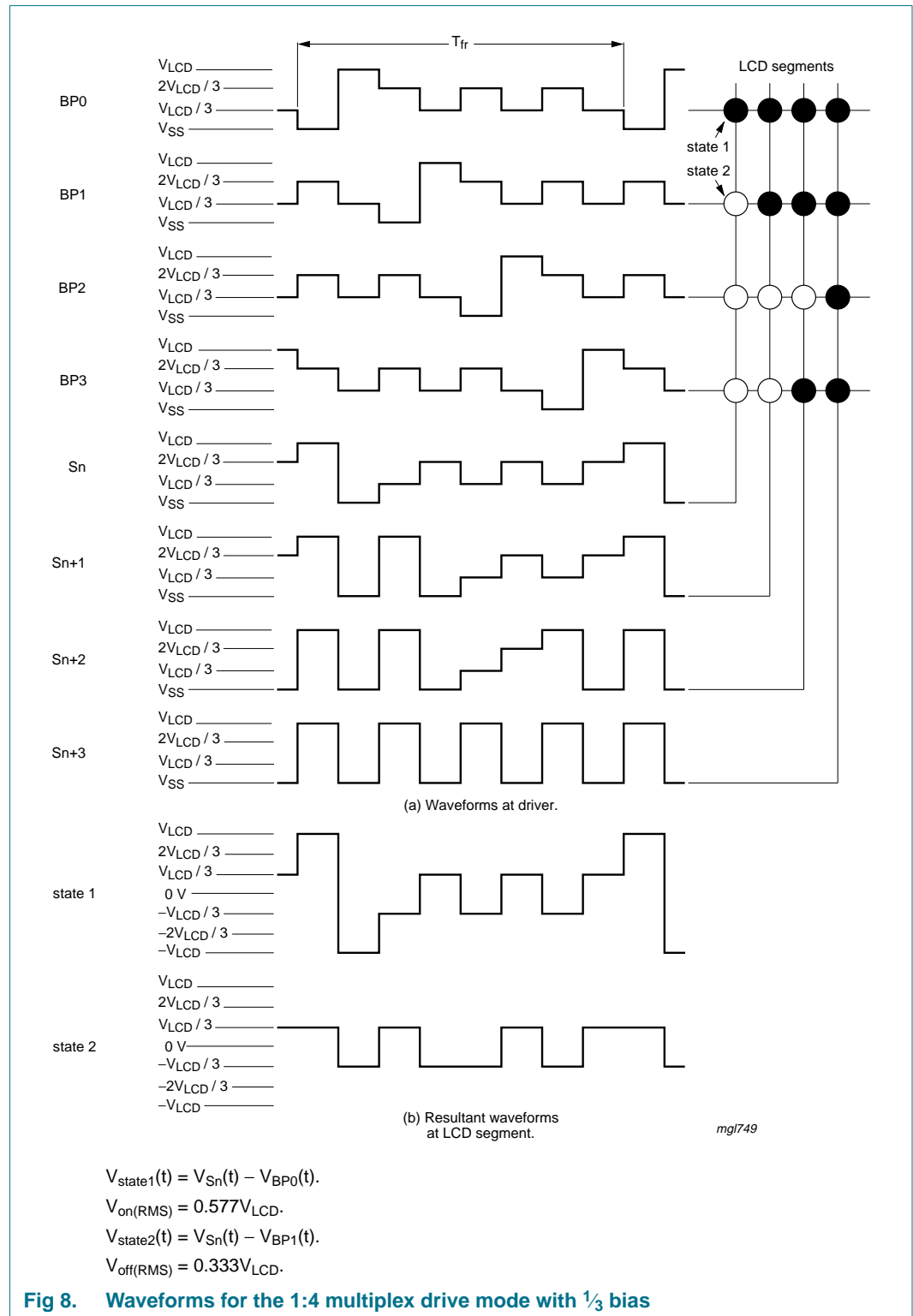

Fig 8. Waveforms for the 1:4 multiplex drive mode with 1/3 bias

7.5 Oscillator

The internal logic and the LCD drive signals of the PCF8532 are timed by a frequency f_{clk} which either is derived from the built-in oscillator frequency f_{osc} ($f_{clk} = \frac{f_{osc}}{64}$) or equals an external clock frequency $f_{clk(ext)}$ ($f_{clk} = f_{clk(ext)}$).

The clock frequency f_{clk} determines the LCD frame frequency f_{fr} (see [Table 15](#)).

7.5.1 Internal clock

The internal logic and the LCD drive signals of the PCF8532 are timed either by the built-in oscillator or by an external clock.

The internal oscillator is enabled by connecting pin OSC to pin V_{SS} . In this case the output from pin CLK provides the clock signal for cascaded PCF8532's in the system. However, the clock signal is only available at the pin CLK, if the display is enabled. The display is enabled using the display enable bit (see [Table 9](#)).

The nominal output clock frequency is like specified in [Table 18](#) with parameter f_{clk} .

7.5.2 External clock

Connecting pin OSC to V_{DD} enables an external clock source. Pin CLK then becomes the external clock input.

A clock signal must always be supplied to the device; removing the clock may freeze the LCD in a DC state.

7.6 Timing and frame frequency

The timing of the PCF8532 organizes the internal data flow of the device. This includes the transfer of display data from the display RAM to the display segment outputs. In cascaded applications, the synchronization signal (\overline{SYNC}) maintains the correct timing relationship between all the PCF8532's in the system.

The clock frequency can be programmed by software such that the nominal frame frequency can be chosen in steps of 5 Hz in the range of 60 Hz to 90 Hz (see [Table 15](#)).

7.7 Display register

The display register holds the display data while the corresponding multiplex signals are generated. There is a one-to-one relationship between the data in the display register, the LCD segment outputs and one column of the display RAM.

7.8 Segment outputs

The LCD drive section includes 160 segment outputs (S0 to S159) which must be connected directly to the LCD. The segment output signals are generated in accordance with the multiplexed backplane signals and with data residing in the display register. When less than 160 segment outputs are required the unused segment outputs must be left open-circuit.

7.9 Backplane outputs

The LCD drive section includes four backplane outputs: BP0 to BP3. The backplane output signals are generated in accordance with the selected LCD drive mode.

- In the 1:4 multiplex drive mode BP0 to BP3 must be connected directly to the LCD.

If less than four backplane outputs are required the unused outputs can be left open-circuit.

- In 1:3 multiplex drive mode BP3 carries the same signal as BP1, therefore these two adjacent outputs can be tied together to give enhanced drive capabilities.
- In 1:2 multiplex drive mode BP0 and BP2, BP1 and BP3 respectively carry the same signals and may also be paired to increase the drive capabilities.
- In static drive mode the same signal is carried by all four backplane outputs and they can be connected in parallel for very high drive requirements.

The pins for the four backplanes BP0 to BP3 are available on both pin bars of the chip. In applications it is possible to use either the pins for the backplanes

- on the top pin bar
- on the bottom pin bar
- or both of them to increase the driving strength of the device.

When using all backplanes available they may be connected to the respective sibling (BP0 on the top pin bar with BP0 on the bottom pin bar and so on).

7.10 Display RAM

The display RAM is a static 160×4 -bit RAM which stores LCD data. A logic 1 in the RAM bit map indicates the on-state of the corresponding LCD element (it is shaded); similarly, a logic 0 indicates the off-state (it is translucent). There is a one-to-one correspondence between the RAM addresses and the segment outputs and between the individual bits of a RAM word and the backplane outputs. The first RAM row corresponds to the 160 elements operated with respect to backplane BP0 (see [Figure 9](#)). In multiplexed LCD applications the segment data of the first, second, third and fourth row of the display RAM are time-multiplexed with BP0, BP1, BP2 and BP3 respectively.

When display data is transmitted to the PCF8532 the display bytes received are stored in the display RAM in accordance with the selected LCD drive mode. The data is stored as it arrives and does not wait for the acknowledge cycle as with the commands. Depending on the current multiplex mode data is stored singularly, in pairs, triplets or quadruplets, e.g. in 1:2 multiplex mode the RAM data is stored every second bit. To illustrate the filling order, an example of a 7-segment numeric display showing all drive modes is given in [Figure 10](#); the RAM filling organization depicted applies equally to other LCD types.

The following applies to [Figure 10](#):

- In static drive mode the eight transmitted data bits are placed in row 0 to eight successive display RAM addresses.
- In 1:2 multiplex mode the eight transmitted data bits are placed in row 0 and 1 to four successive display RAM addresses.

- In 1:3 multiplex mode the bits are placed in row 0, 1 and 2 to three successive addresses, with bit 2 of the third address left unchanged. This last bit may, if necessary, be controlled by an additional transfer to this address but care should be taken to avoid overwriting adjacent data because always full bytes are transmitted.
- In the 1:4 multiplex mode the eight transmitted data bits are placed in row 0, 1, 2 and 3 to two successive display RAM addresses.

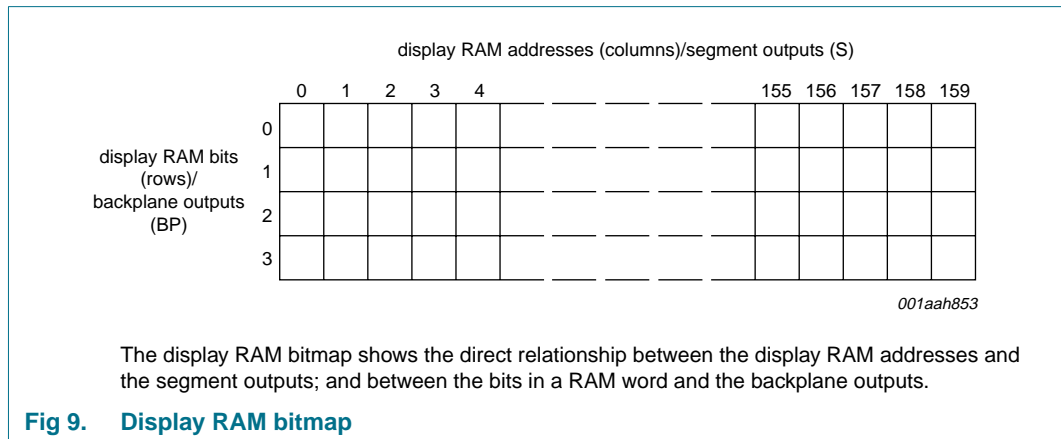

7.11 Data pointer

The addressing mechanism for the display RAM is realized using the data pointer.

This allows the loading of an individual display data byte, or a series of display data bytes, into any location of the display RAM. The sequence commences with the initialization of the data pointer by the load-data-pointer-MSB and load-data-pointer-LSB commands.

Following this two commands, an arriving data byte is stored starting at the display RAM address indicated by the data pointer. The filling order is shown in [Figure 10](#).

The data pointer is automatically incremented in accordance with the chosen LCD configuration.

The contents of the data pointer are incremented as follows:

- In static drive mode by eight
- In 1:2 multiplex drive mode by four
- In 1:3 multiplex drive mode by three
- In 1:4 multiplex drive mode by two

If the data pointer reaches 159 it is automatically wrapped around to address 0, consequently the subaddress counter is incremented.

If an I²C-bus data access is terminated early then the state of the data pointer is unknown. The data pointer must be re-written prior to further RAM accesses.

drive mode	LCD segments	LCD backplanes	display RAM filling order	transmitted display byte																																																								
static			<table border="1"> <tr> <td>n</td> <td>n+1</td> <td>n+2</td> <td>n+3</td> <td>n+4</td> <td>n+5</td> <td>n+6</td> <td>n+7</td> </tr> <tr> <td>c</td> <td>b</td> <td>a</td> <td>f</td> <td>g</td> <td>e</td> <td>d</td> <td>DP</td> </tr> <tr> <td>x</td> <td>x</td> <td>x</td> <td>x</td> <td>x</td> <td>x</td> <td>x</td> <td>x</td> </tr> <tr> <td>x</td> <td>x</td> <td>x</td> <td>x</td> <td>x</td> <td>x</td> <td>x</td> <td>x</td> </tr> <tr> <td>x</td> <td>x</td> <td>x</td> <td>x</td> <td>x</td> <td>x</td> <td>x</td> <td>x</td> </tr> </table>	n	n+1	n+2	n+3	n+4	n+5	n+6	n+7	c	b	a	f	g	e	d	DP	x	x	x	x	x	x	x	x	x	x	x	x	x	x	x	x	x	x	x	x	x	x	x	x	<table border="1"> <tr> <td colspan="4">MSB</td> <td colspan="4">LSB</td> </tr> <tr> <td>c</td> <td>b</td> <td>a</td> <td>f</td> <td>g</td> <td>e</td> <td>d</td> <td>DP</td> </tr> </table>	MSB				LSB				c	b	a	f	g	e	d	DP
n	n+1	n+2	n+3	n+4	n+5	n+6	n+7																																																					
c	b	a	f	g	e	d	DP																																																					
x	x	x	x	x	x	x	x																																																					
x	x	x	x	x	x	x	x																																																					
x	x	x	x	x	x	x	x																																																					
MSB				LSB																																																								
c	b	a	f	g	e	d	DP																																																					
1:2 multiplex			<table border="1"> <tr> <td>n</td> <td>n+1</td> <td>n+2</td> <td>n+3</td> </tr> <tr> <td>a</td> <td>f</td> <td>e</td> <td>d</td> </tr> <tr> <td>b</td> <td>g</td> <td>c</td> <td>DP</td> </tr> <tr> <td>x</td> <td>x</td> <td>x</td> <td>x</td> </tr> <tr> <td>x</td> <td>x</td> <td>x</td> <td>x</td> </tr> </table>	n	n+1	n+2	n+3	a	f	e	d	b	g	c	DP	x	x	x	x	x	x	x	x	<table border="1"> <tr> <td colspan="4">MSB</td> <td colspan="4">LSB</td> </tr> <tr> <td>a</td> <td>b</td> <td>f</td> <td>g</td> <td>e</td> <td>c</td> <td>d</td> <td>DP</td> </tr> </table>	MSB				LSB				a	b	f	g	e	c	d	DP																				
n	n+1	n+2	n+3																																																									
a	f	e	d																																																									
b	g	c	DP																																																									
x	x	x	x																																																									
x	x	x	x																																																									
MSB				LSB																																																								
a	b	f	g	e	c	d	DP																																																					
1:3 multiplex			<table border="1"> <tr> <td>n</td> <td>n+1</td> <td>n+2</td> </tr> <tr> <td>b</td> <td>a</td> <td>f</td> </tr> <tr> <td>DP</td> <td>d</td> <td>e</td> </tr> <tr> <td>c</td> <td>g</td> <td>x</td> </tr> <tr> <td>x</td> <td>x</td> <td>x</td> </tr> </table>	n	n+1	n+2	b	a	f	DP	d	e	c	g	x	x	x	x	<table border="1"> <tr> <td colspan="4">MSB</td> <td colspan="4">LSB</td> </tr> <tr> <td>b</td> <td>DP</td> <td>c</td> <td>a</td> <td>d</td> <td>g</td> <td>f</td> <td>e</td> </tr> </table>	MSB				LSB				b	DP	c	a	d	g	f	e																									
n	n+1	n+2																																																										
b	a	f																																																										
DP	d	e																																																										
c	g	x																																																										
x	x	x																																																										
MSB				LSB																																																								
b	DP	c	a	d	g	f	e																																																					
1:4 multiplex			<table border="1"> <tr> <td>n</td> <td>n+1</td> </tr> <tr> <td>a</td> <td>f</td> </tr> <tr> <td>c</td> <td>e</td> </tr> <tr> <td>b</td> <td>g</td> </tr> <tr> <td>DP</td> <td>d</td> </tr> </table>	n	n+1	a	f	c	e	b	g	DP	d	<table border="1"> <tr> <td colspan="4">MSB</td> <td colspan="4">LSB</td> </tr> <tr> <td>a</td> <td>c</td> <td>b</td> <td>DP</td> <td>f</td> <td>e</td> <td>g</td> <td>d</td> </tr> </table>	MSB				LSB				a	c	b	DP	f	e	g	d																														
n	n+1																																																											
a	f																																																											
c	e																																																											
b	g																																																											
DP	d																																																											
MSB				LSB																																																								
a	c	b	DP	f	e	g	d																																																					

001aag281

x = data bit unchanged

Fig 10. Relationships between LCD layout, drive mode, display RAM filling order and display data transmitted over the I²C-bus

7.12 Subaddress counter

The storage of display data is conditioned by the contents of the subaddress counter. Storage is allowed only when the content of the subaddress counter agree with the hardware subaddress applied to A0 and A1. The subaddress counter value is defined by the device-select command. If the content of the subaddress counter and the hardware subaddress do not match then data storage is inhibited but the data pointer is incremented as if data storage had taken place. The subaddress counter is also incremented when the data pointer overflows.

The storage arrangements described lead to extremely efficient data loading in cascaded applications. When a series of display bytes are sent to the display RAM, automatic wrap-over to the next PCF8532 occurs when the last RAM address is exceeded. Subaddressing across device boundaries is successful even if the change to the next device in the cascade occurs within a transmitted character (such as during the 54th display data byte transmitted in 1:3 multiplex mode).

The hardware subaddress must not be changed whilst the device is being accessed on the I²C-bus interface.

7.13 Output bank selector

The output bank selector selects one of the four bits per display RAM address for transfer to the display register. The actual bit selected depends on the LCD drive mode in operation and on the instant in the multiplex sequence.

- In 1:4 multiplex mode, all RAM addresses of bit 0 are selected, these are followed by the contents of bit 1, bit 2 and then bit 3
- In 1:3 multiplex mode, bits 0, 1 and 2 are selected sequentially
- In 1:2 multiplex mode, bits 0 and 1 are selected
- In the static mode, bit 0 is selected.

The $\overline{\text{SYNC}}$ signal will reset these sequences to the following starting points:

- Bit 3 for 1:4 multiplex mode
- Bit 2 for 1:3 multiplex mode
- Bit 1 for 1:2 multiplex mode
- Bit 0 for static mode

The PCF8532 includes a RAM bank switching feature in the static and 1:2 multiplex drive modes. In the static drive mode, the bank-select command may request the contents of bit 2 to be selected for display instead of the contents of bit 0. In the 1:2 multiplex drive mode, the contents of bits 2 and 3 may be selected instead of bits 0 and 1. This gives the provision for preparing display information in an alternative bank and to be able to switch to it once it is assembled.

7.14 Input bank selector

The input bank selector loads display data into the display RAM in accordance with the selected LCD drive configuration. Display data can be loaded in bit 2 in static drive mode or in bits 2 and 3 in 1:2 multiplex drive mode by using the bank-select command. The input bank selector functions independently to the output bank selector.

7.15 Blinker

The display blinking capabilities of the PCF8532 are very versatile. The whole display can blink at frequencies selected by the blink-select command. The blink frequencies are fractions of the clock frequency. The ratios between the clock and blink frequencies depend on the blink mode in which the device is operating, see [Table 6](#).

Table 6. Blink frequencies
Assuming that $f_{clk} = 1.800\text{ kHz}$.

Blink mode	Operating mode ratio	Blink frequency
off	-	blinking off
1	$f_{blink} = \frac{f_{clk}}{768}$	~2.34 Hz
2	$f_{blink} = \frac{f_{clk}}{1536}$	~1.17 Hz
3	$f_{blink} = \frac{f_{clk}}{3072}$	~0.59 Hz

An additional feature is for an arbitrary selection of LCD segments to blink. This applies to the static and 1:2 multiplex drive modes and can be implemented without any communication overheads. By means of the output bank selector, the displayed RAM banks are exchanged with alternate RAM banks at the blink frequency. This mode can also be specified by the blink-select command.

In the 1:3 and 1:4 multiplex modes, where no alternate RAM bank is available, groups of LCD segments can blink selectively by changing the display RAM data at fixed time intervals.

If the entire display can blink at a frequency other than the nominal blink frequency. This can be effectively performed by resetting and setting the display enable bit E at the required rate using the mode-set command (see [Table 6](#)).

7.16 Characteristics of the I²C-bus

The I²C-bus is for bidirectional, two-line communication between different ICs or modules. The two lines are a Serial Data line (SDA) and a Serial Clock Line (SCL). Both lines must be connected to a positive supply via a pull-up resistor when connected to the output stages of a device. Data transfer may be initiated only when the bus is not busy.

By connecting pin SDAACK to pin SDA on the PCF8532, the SDA line becomes fully I²C-bus compatible. Having the acknowledge output separated from the serial data line is advantageous in Chip-On-Glass (COG) applications. In COG applications where the track resistance from the SDAACK pin to the system SDA line can be significant, a potential divider is generated by the bus pull-up resistor and the Indium Tin Oxide (ITO) track resistance. It is possible that during the acknowledge cycle the PCF8532 will not be able to create a valid logic 0 level. By splitting the SDA input from the output the device could be used in a mode that ignores the acknowledge bit. In COG applications where the acknowledge cycle is required, it is necessary to minimize the track resistance from the SDAACK pin to the system SDA line to guarantee a valid LOW level.

The following definition assumes SDA and SDAACK are connected and refers to the pair as SDA.

7.16.1 Bit transfer

One data bit is transferred during each clock pulse. The data on the SDA line must remain stable during the HIGH period of the clock pulse as changes in the data line at this time will be interpreted as a control signal. Bit transfer is shown in [Figure 11](#).

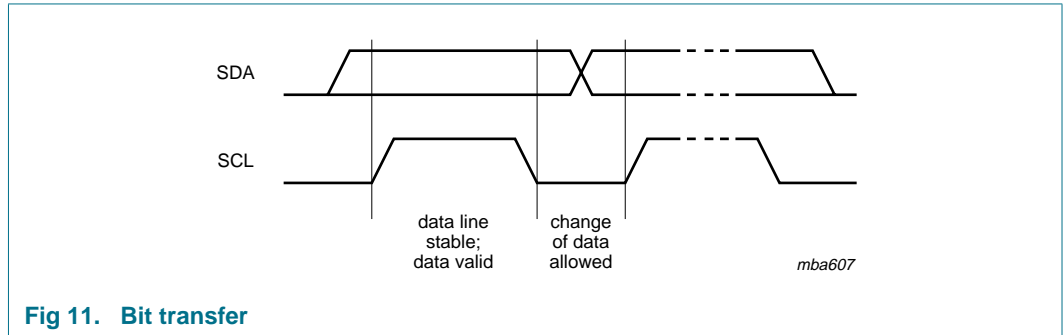

7.16.2 START and STOP conditions

Both data and clock lines remain HIGH when the bus is not busy.

A HIGH-to-LOW change of the data line, while the clock is HIGH is defined as the START condition (S).

A LOW-to-HIGH change of the data line while the the clock is HIGH is defined as the STOP condition (P).

The START and STOP conditions are shown in [Figure 12](#).

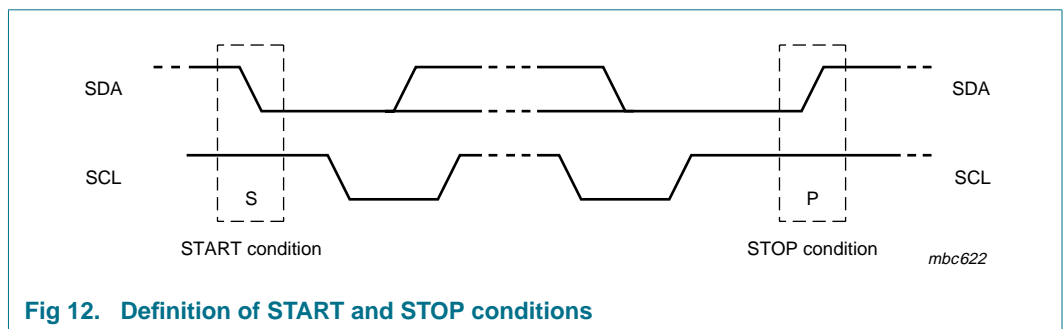

7.16.3 System configuration

A device generating a message is a transmitter, a device receiving a message is the receiver. The device that controls the message is the master and the devices which are controlled by the master are the slaves. The system configuration is shown in [Figure 13](#).

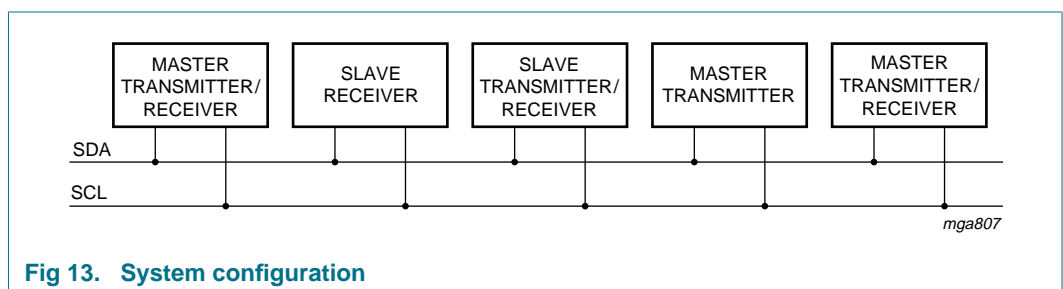

7.16.4 Acknowledge

The number of data bytes transferred between the START and STOP conditions from transmitter to receiver is unlimited. Each byte of eight bits is followed by an acknowledge bit. The acknowledge bit is a HIGH level signal put on the bus by the transmitter during which time the master generates an extra acknowledge related clock pulse.

- A slave receiver which is addressed must generate an acknowledge after the reception of each byte.
- Also a master receiver must generate an acknowledge after the reception of each byte that has been clocked out of the slave transmitter.
- The device that acknowledges must pull-down the SDA line during the acknowledge clock pulse, so that the SDA line is stable LOW during the HIGH period of the acknowledge related clock pulse (set-up and hold times must be taken into consideration).
- A master receiver must signal an end of data to the transmitter by not generating an acknowledge on the last byte that has been clocked out of the slave. In this event the transmitter must leave the data line HIGH to enable the master to generate a STOP condition.

Acknowledgement on the I²C-bus is shown in [Figure 14](#).

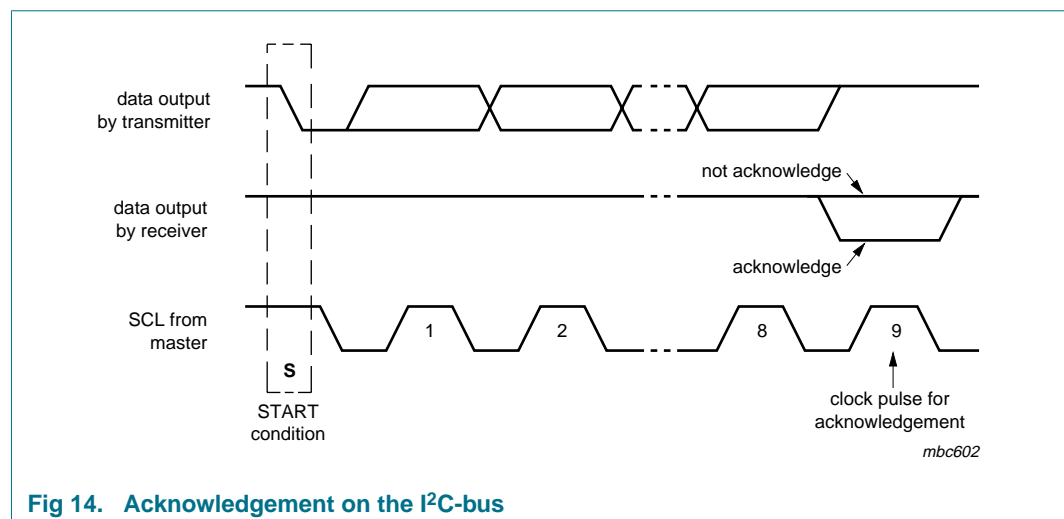

Fig 14. Acknowledgement on the I²C-bus

7.16.5 I²C-bus controller

The PCF8532 acts as an I²C-bus slave receiver. It does not initiate I²C-bus transfers or transmit data to an I²C-bus master receiver. The only data output from the PCF8532 are the acknowledge signals of the selected devices. Device selection depends on the I²C-bus slave address, on the transferred command data and on the hardware subaddress.

In single device application, the hardware subaddress inputs A0 and A1 are normally tied to V_{SS} which defines the hardware subaddress 0. In multiple device applications A0 and A1 are tied to V_{SS} or V_{DD} in accordance with a binary coding scheme such that no two devices with a common I²C-bus slave address have the same hardware subaddress.

7.16.6 Input filters

To enhance noise immunity in electrically adverse environments, RC low-pass filters are provided on the SDA and SCL lines.

7.16.7 I²C-bus protocol

Two I²C-bus slave addresses (0111 000 and 0111 001) are reserved for the PCF8532. The least significant bit of the slave address that a PCF8532 responds to is defined by the level tied at its input SA0. The PCF8532 is a write only device and does not respond to a read access. Two types of PCF8532 can be distinguished on the same I²C-bus which allows:

- Up to 8 PCF8532's on the same I²C-bus for very large LCD applications
- The use of two types of LCD multiplex on the same I²C-bus.

The I²C-bus protocol is shown in [Figure 15](#). The sequence is initiated with a START condition (S) from the I²C-bus master which is followed by one of the two PCF8532 slave addresses available. All PCF8532's with the corresponding SA0 level acknowledge in parallel to the slave address, but all PCF8532's with the alternative SA0 level ignore the whole I²C-bus transfer.

After acknowledgement, a control byte follows which defines if the next byte is RAM or command information. The control byte also defines if the next following byte is a control byte or further RAM/command data.

In this way it is possible to configure the device then fill the display RAM with little overhead.

The command bytes and control bytes are also acknowledged by all addressed PCF8532's connected to the bus.

The display bytes are stored in the display RAM at the address specified by the data pointer and the subaddress counter. Both data pointer and subaddress counter are automatically updated and the data is directed to the intended PCF8532 device.

The acknowledgement after each byte is made only by the (A0 and A1) addressed PCF8532. After the last (display) byte, the I²C-bus master issues a STOP condition (P). Alternatively a START may be issued to RESTART an I²C-bus access.

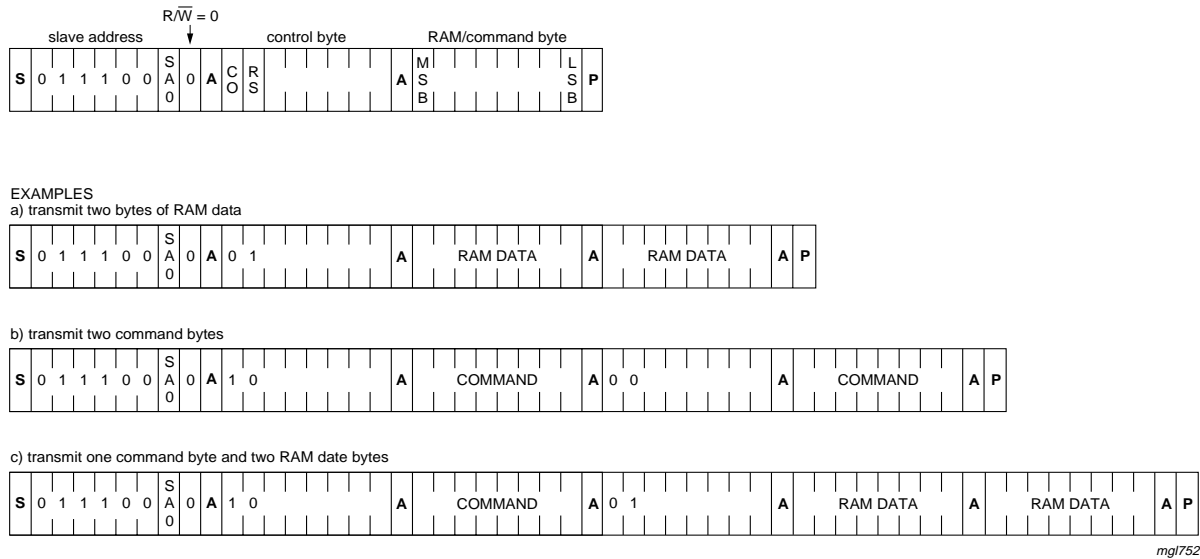

Fig 15. I²C-bus protocol

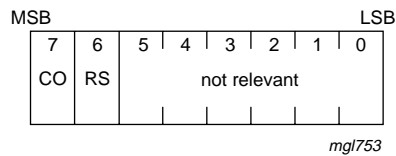

Fig 16. Format of control byte

Table 7. Load-data-pointer command bit description

Bit	Symbol	Value	Description
7	CO		continue bit
		0	last control byte
		1	control bytes continue
6	RS		register selection
		0	command register
		1	data register
5 to 0	-		not relevant

7.17 Command decoder

The command decoder identifies command bytes that arrive on the I²C-bus. The commands available to the PCF8532 are defined in [Table 8](#).

Table 8. Definition of PCF8532 commands

Command	Operation code									Reference
	7	6	5	4	3	2	1	0		
mode-set	1	1	0	0	E	B	M1	M0		Table 9
load-data-pointer-MSB	0	0	0	0	P7	P6	P5	P4		Table 10
load-data-pointer-LSB	0	1	0	0	P3	P2	P1	P0		Table 11
device-select	1	1	1	0	0	0	A1	A0		Table 12
bank-select	1	1	1	1	1	0	I	O		Table 13
blink-select	1	1	1	1	0	A	BF1	BF0		Table 14
frequency-prescaler	1	1	1	0	1	F2	F1	F0		Table 15

Table 9. Mode-set command bits description

Bit	Symbol	Value	Description
7 to 4	-	1100	fixed value
3	E		display status
		0 ^[1]	disabled (blank) ^[2]
		1	enabled
2	B		LCD bias configuration
		0 ^[1]	$\frac{1}{3}$ bias
		1	$\frac{1}{2}$ bias
1 to 0	M[1:0]		LCD drive mode selection
		01	static; BP0
		10	1:2 multiplex; BP0, BP1
		11	1:3 multiplex; BP0, BP1, BP2
		00 ^[1]	1:4 multiplex; BP0, BP1, BP2, BP3

[1] Power-on and reset value.

[2] The possibility to disable the display allows implementation of blinking under external control; the enable bit determines also whether the internal clock signal is available at the CLK pin (see [Section 7.5.1](#)).

Table 10. Load-data-pointer-MSB command bits description

Bit	Symbol	Value	Description
7 to 4	-	0000	fixed value
3 to 0	P[7:4]	0000 ^[1] to 1001	P7 to P4 defines the first 4 (most significant) bits of the data pointer that indicates one of the 160 display RAM addresses

[1] Power-on and reset value.

Table 11. Load-data-pointer-LSB command bits description

Bit	Symbol	Value	Description
7 to 4	-	0100	fixed value
3 to 0	P[3:0]	0000 ^[1] to 1111	P3 to P0 defines the last 4 (least significant) bits of the data pointer that indicates one of the 160 display RAM addresses

[1] Power-on and reset value.

Table 12. Device-select command bits description

Bit	Symbol	Value	Description
7 to 2	-	111000	fixed value
1 to 0	A[1:0]	00 ^[1] to 11	two bits of immediate data, bits A0 to A1, are transferred to the subaddress counter to define one of four hardware subaddresses

[1] Power-on and reset value.

Table 13. Bank-select command bits description

Bit	Symbol	Value	Description	
			Static	1:2 multiplex ^[1]
7 to 2	-	111110	fixed value	
1	I		input bank selection ; storage of arriving display data	
		0 ^[2]	RAM bit 0	RAM bits 0 and 1
		1	RAM bit 2	RAM bits 2 and 3
0	O		output bank selection ; retrieval of LCD display data	
		0 ^[2]	RAM bit 0	RAM bits 0 and 1
		1	RAM bit 2	RAM bits 2 and 3

[1] The bank-select command has no effect in 1:3 and 1:4 multiplex drive modes.

[2] Power-on and reset value.

Table 14. Blink-select command bits description

Bit	Symbol	Value	Description
7 to 3	-	11110	fixed value
2	A		blink mode selection
		0 ^[1]	normal blinking ^[2]
		1	alternate RAM bank blinking ^[3]
1 to 0	BF[1:0]		blink frequency selection
		00 ^[1]	off
		01	1
		10	2
		11	3

[1] Power-on and reset value.

[2] Normal blinking is assumed when the LCD multiplex drive modes 1:3 or 1:4 are selected.

[3] Alternating RAM bank blinking does not apply in 1:3 and 1:4 multiplex drive modes.

Table 15. Frame-frequency prescaler

Bit	Symbol	Value	Description	
			Nominal frame frequency ^[1]	Equation
7 to 4	-	11101	fixed value	
3 to 0	F[2:0]		defines the division factor for the frame frequency	
		000	60 Hz	$f_{fr} = \frac{64}{80} \times \frac{f_{clk}}{24}$
		001	65 Hz	$f_{fr} = \frac{64}{74} \times \frac{f_{clk}}{24}$
		010	70 Hz	$f_{fr} = \frac{64}{68} \times \frac{f_{clk}}{24}$
		011 ^[2]	75 Hz	$f_{fr} = \frac{f_{clk}}{24}$
		100	80 Hz	$f_{fr} = \frac{64}{60} \times \frac{f_{clk}}{24}$
		101	85 Hz	$f_{fr} = \frac{64}{56} \times \frac{f_{clk}}{24}$
		110	90 Hz	$f_{fr} = \frac{64}{53} \times \frac{f_{clk}}{24}$
		111	75 Hz	$f_{fr} = \frac{f_{clk}}{24}$

[1] Nominal frame frequency calculated for an internal operating frequency of 1.800 kHz.

[2] Power-on and reset value.

7.18 Display controller

The display controller executes the commands identified by the command decoder. It contains the status registers of the PCF8532 and co-ordinates their effects. The display controller is also responsible for loading display data into the display RAM as required by the filling order.

8. Internal circuitry

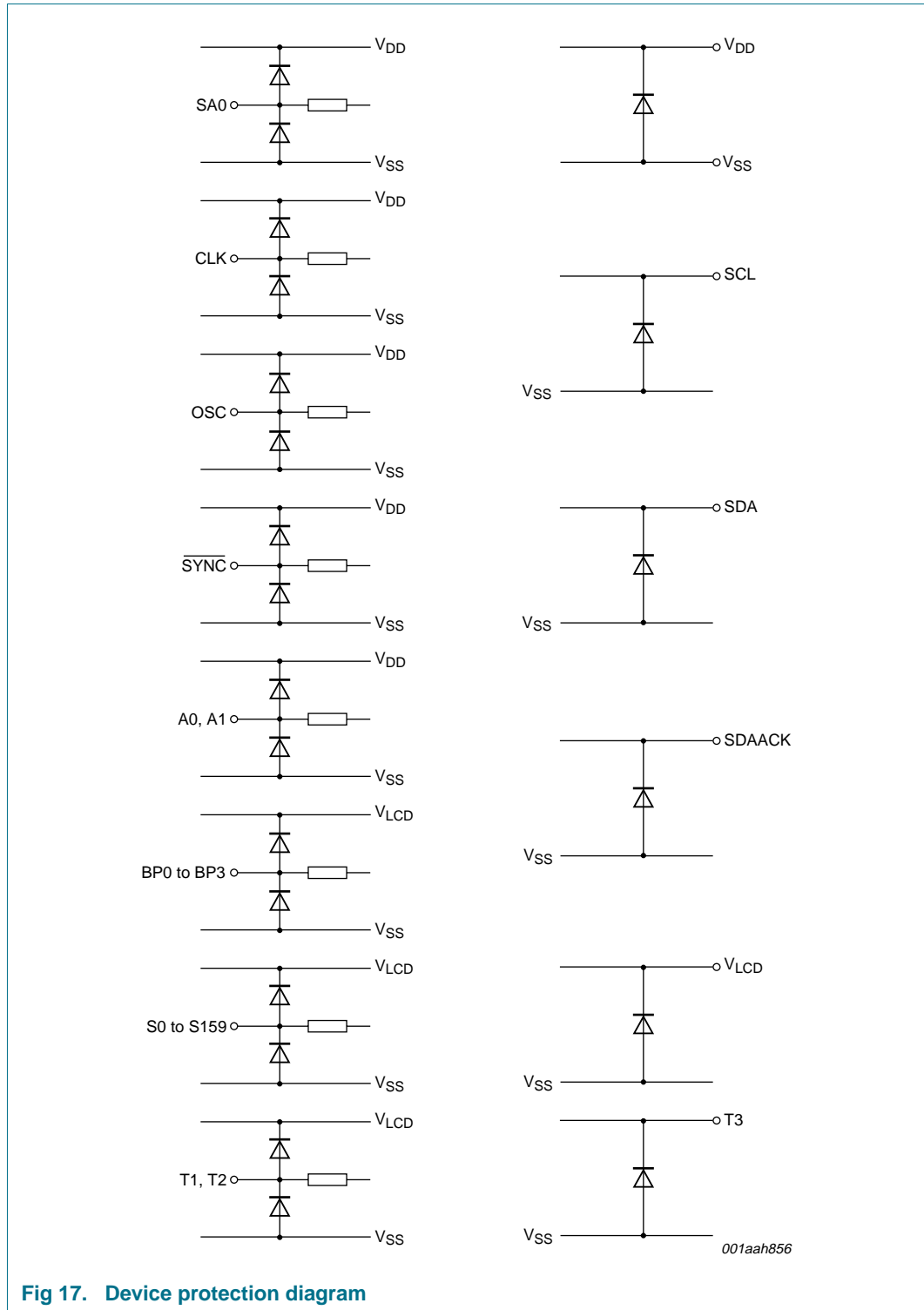

Fig 17. Device protection diagram

9. Limiting values

CAUTION



Static voltages across the liquid crystal display can build up when the LCD supply voltage (V_{LCD}) is on while the IC supply voltage (V_{DD}) is off, or vice versa. This may cause unwanted display artifacts. To avoid such artifacts, V_{LCD} and V_{DD} must be applied or removed together.

Table 16. Limiting values

In accordance with the Absolute Maximum Rating System (IEC 60134).^[1]

Symbol	Parameter	Conditions	Min	Max	Unit
V_{DD}	supply voltage		-0.5	+6.5	V
I_{DD}	supply current		-50	+50	mA
V_{LCD}	LCD supply voltage		-0.5	+9.0	V
$I_{DD(LCD)}$	LCD supply current		-50	+50	mA
V_I	input voltage	on pins CLK, \overline{SYNC} , SA0, OSC, SDA, SCL and A0, A1, T1, T2, T3	-0.5	+6.5	V
I_I	input current		-10	+10	mA
V_O	output voltage	on pins S0 to S159 and BP0 to BP3	-0.5	+7.5	V
		on pins SDAACK, CLK, \overline{SYNC}	-0.5	+6.5	V
I_O	output current		-10	+10	mA
I_{SS}	ground supply current		-50	+50	mA
P_{tot}	total power dissipation		-	400	mW
P/out	power dissipation per output		-	100	mW
T_{stg}	storage temperature		^[2] -65	+150	°C
V_{esd}	electrostatic discharge voltage	HBM	^[3] -	±4500	V
		MM	^[4] -	±250	V
I_{lu}	latch-up current		^[5] -	200	mA

[1] Stresses above these values listed may cause permanent damage to the device.

[2] According to the NXP store and transport conditions (document *SNW-SQ-623*) the devices have to be stored at a temperature of +5 °C to +45 °C and a humidity of 25 % to 75 %.

[3] Pass level; Human Body Model (HBM) according to JESD22-A114.

[4] Pass level; Machine Model (MM), according to JESD22-A115.

[5] Pass level; Latch-up testing, according to JESD78.

10. Static characteristics

Table 17. Static characteristics

$V_{DD} = 1.8\text{ V to }5.5\text{ V}$; $V_{SS} = 0\text{ V}$; $V_{LCD} = 2.5\text{ V to }8.0\text{ V}$; $T_{amb} = -40\text{ }^{\circ}\text{C to }+85\text{ }^{\circ}\text{C}$; unless otherwise specified.

Symbol	Parameter	Conditions	Min	Typ	Max	Unit	
Supplies							
V_{DD}	supply voltage		1.8	-	5.5	V	
V_{LCD}	LCD supply voltage		1.8	-	8.0	V	
I_{DD}	supply current	$f_{clk(ext)} = 1.800\text{ kHz}$	[1][2]	-	4	20	μA
		with internal oscillator running	[1]	-	18	60	μA
$I_{DD(LCD)}$	LCD supply current	$f_{clk(ext)} = 1.800\text{ kHz}$	[1][2]	-	30	70	μA
		with internal oscillator running	[1]	-	30	70	μA
Logic							
V_I	input voltage	on pins SDA, SDAACK and SCL	-0.5	-	5.5	V	
		all other input pins	-0.5	-	$(V_{DD} + 0.5) \leq 5.5$	V	
V_{IH}	HIGH-level input voltage	on pins CLK, $\overline{\text{SYNC}}$, OSC, A0, A1, SA0, SCL and SDA	$0.7V_{DD}$	-	-	V	
V_{IL}	LOW-level input voltage	on pins CLK, $\overline{\text{SYNC}}$, OSC, A0, A1, SA0, SCL and SDA	-	-	$0.3V_{DD}$	V	
V_O	output voltage	on pins SCL and $\overline{\text{SYNC}}$	-0.5	-	$(V_{DD} + 0.5) \leq 5.5$	V	
		pin SDAACK	-0.5	-	5.5	V	
I_{OH}	HIGH-level output current	$V_{OH} = 4.6\text{ V}$; $V_{DD} = 5\text{ V}$; on pin CLK	1.5	-	-	mA	
I_{OL}	LOW-level output current	$V_{OL} = 0.4\text{ V}$; $V_{DD} = 5\text{ V}$;					
		on pins CLK and $\overline{\text{SYNC}}$	-	-	-1.5	mA	
		on pin SDAACK	-	-	-3	mA	
V_{POR}	power-on reset voltage		1.0	1.3	1.6	V	
I_L	leakage current	$V_I = V_{DD}$ or V_{SS} ; on pin OSC, CLK, A0, A1, SA0, SDA, SDAACK and SCL	-1	-	+1	μA	
LCD outputs							
ΔV_O	output voltage variation	on pins BP0 to BP3 and S0 to S159	[3][4]	-30	-	+30	mV
R_O	output resistance	$V_{LCD} = 5\text{ V}$; on pins BP0 to BP3	-	1.5	5	$\text{k}\Omega$	
		$V_{LCD} = 5\text{ V}$; on pins S0 to S159	-	2.0	5	$\text{k}\Omega$	

[1] LCD outputs are open-circuit; inputs at V_{SS} or V_{DD} ; I²C-bus inactive; $V_{LCD} = 8.0\text{ V}$, $V_{DD} = 5.0\text{ V}$ and RAM written with all logic 1.

[2] External clock with 50 % duty factor.

[3] Variation between any 2 backplanes on a given voltage level; static measured.

[4] Variation between any 2 segments on a given voltage level; static measured.

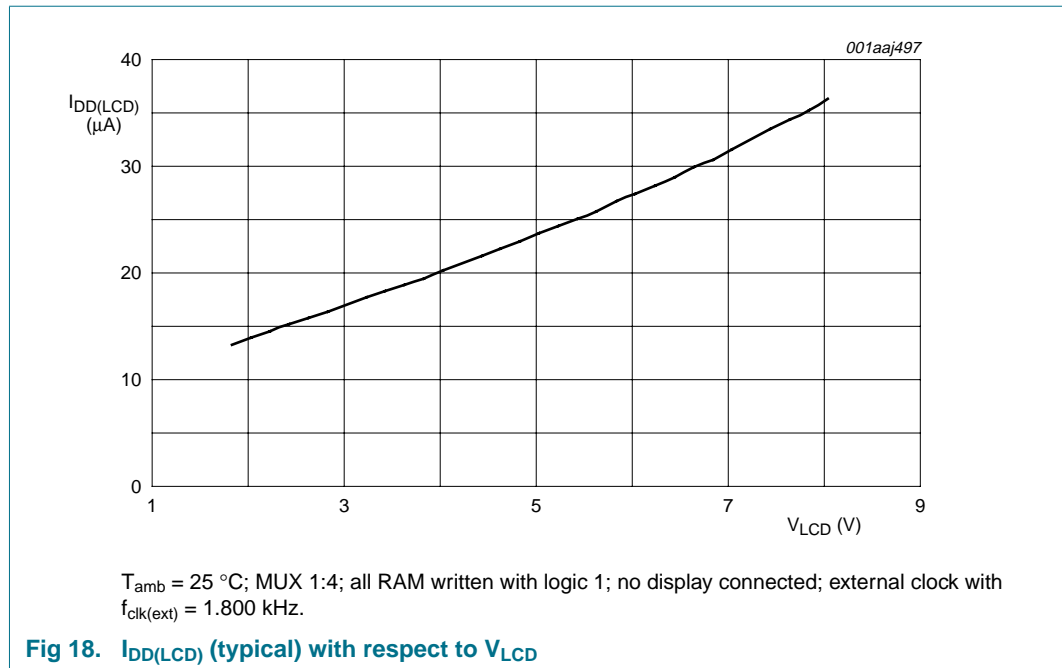

11. Dynamic characteristics

Table 18. Dynamic characteristics

$V_{DD} = 1.8\text{ V to }5.5\text{ V}$; $V_{SS} = 0\text{ V}$; $V_{LCD} = 2.5\text{ V to }8.0\text{ V}$; $T_{amb} = -40\text{ }^{\circ}\text{C to }+85\text{ }^{\circ}\text{C}$; unless otherwise specified.

Symbol	Parameter	Conditions	Min	Typ	Max	Unit
f_{clk}	clock frequency	on pin CLK; see Table 15	900	1800	3000	Hz
$f_{clk(ext)}$	external clock frequency		700	-	5000	Hz
$t_{clk(H)}$	HIGH-level clock time	external clock source used	100	-	-	μs
$t_{clk(L)}$	LOW-level clock time	external clock source used	100	-	-	μs
$t_{PD(SYNC_N)}$	$\overline{\text{SYNC}}$ propagation delay		-	30	-	ns
t_{SYNC_NL}	$\overline{\text{SYNC}}$ LOW time		100	-	-	μs
$t_{PD(drv)}$	driver propagation delay	$V_{LCD} = 5\text{ V}$	-	10	-	μs
Timing characteristics: I²C-bus						
f_{SCL}	SCL clock frequency		-	-	400	kHz
t_{BUF}	bus free time between a STOP and START condition		1.3	-	-	μs
$t_{HD;STA}$	hold time (repeated) START condition		0.6	-	-	μs
$t_{SU;STA}$	set-up time for a repeated START condition		0.6	-	-	μs
$t_{VD;ACK}$	data valid acknowledge time		-	-	1.2	μs
t_{HIGH}	HIGH period of the SCL clock		0.6	-	-	μs
t_{LOW}	LOW period of the SCL clock		1.3	-	-	μs
t_f	fall time	of both SDA and SCL signals	-	-	0.3	μs
t_r	rise time	of both SDA and SCL signals	-	-	0.3	μs
C_b	capacitive load for each bus line		-	-	400	pF
$t_{SU;DAT}$	data set-up time		200	-	-	ns
$t_{HD;DAT}$	data hold time		0	-	-	ns
$t_{SU;STO}$	set-up time for STOP condition		0.6	-	-	μs
$t_{w(spikes)}$	spike pulse width		-	-	50	ns

- [1] Typical output duty factor: 50 % measured at the CLK output pin.
- [2] For $f_{clk(ext)} > 4\text{ kHz}$ it is recommended to use an external pull-up resistor between pin $\overline{\text{SYNC}}$ and pin V_{DD} . The value of the resistor should be between 100 k Ω and 1 M Ω . This resistor should be present even when no cascading configuration is used!
- [3] All timing values are valid within the operating supply voltage and ambient temperature range and are referenced to V_{IL} and V_{IH} with an input voltage swing of V_{SS} to V_{DD} .

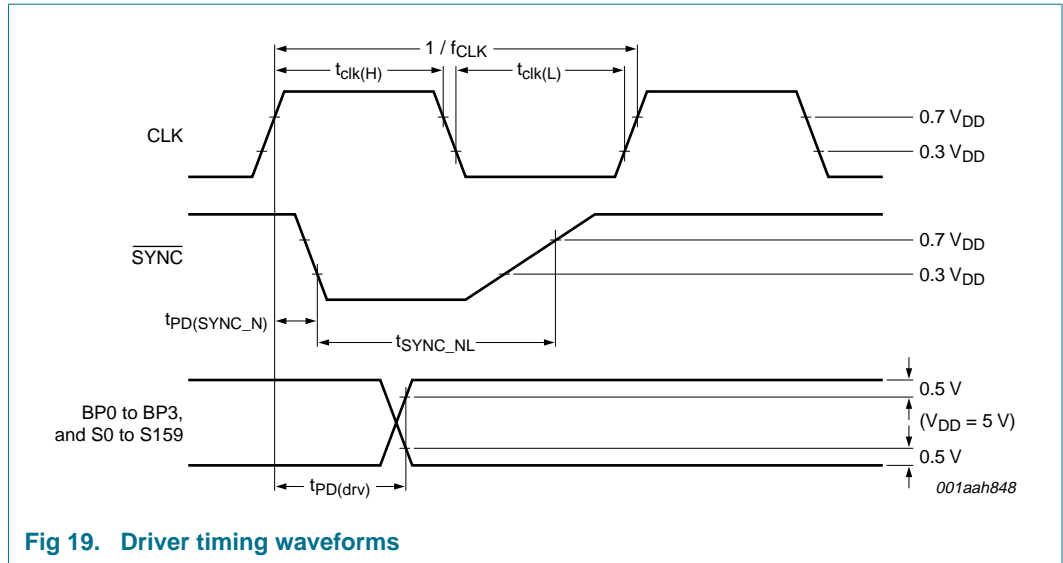

Fig 19. Driver timing waveforms

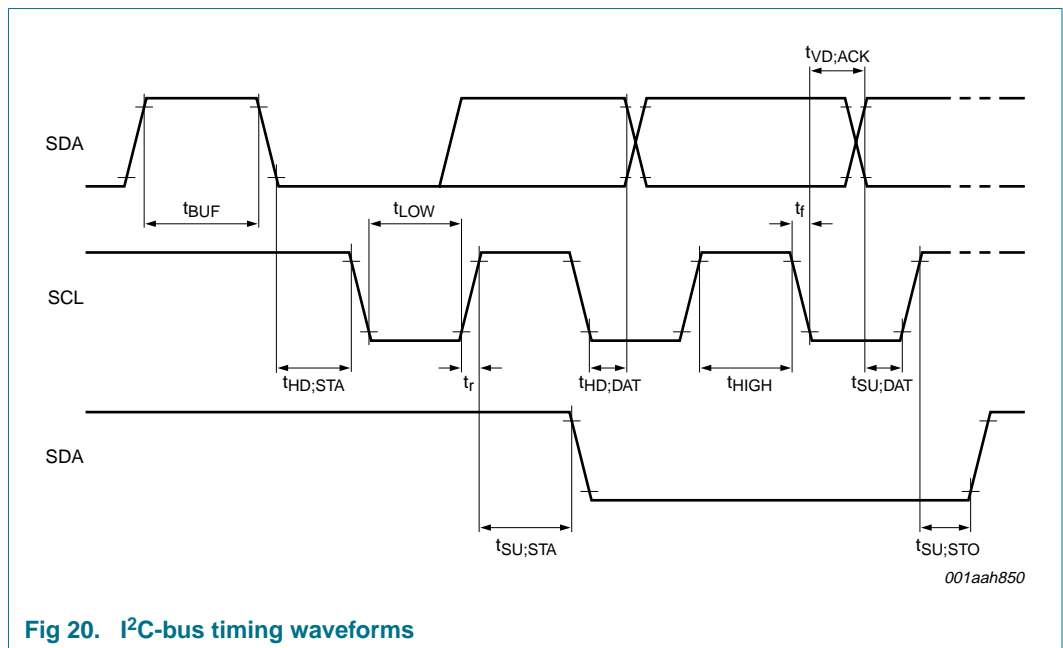

Fig 20. I²C-bus timing waveforms

12. Application information

12.1 Cascaded operation

In large display configurations, up to 8 PCF8532's can be distinguished on the same I²C-bus by using the 2-bit hardware subaddress (A0 and A1) and the programmable I²C-bus slave address (SA0). When cascaded PCF8532's are synchronized, they can share the backplane signals from one of the devices in the cascade. Such an arrangement is cost-effective in large LCD applications since the backplane outputs of only one device need to be through-plated to the backplane electrodes of the display. The other PCF8532's of the cascade contribute additional segment outputs but their backplane outputs are left open-circuit (see [Figure 21](#)).

For display sizes that are not multiple of 640 elements, a mixed cascaded system can be considered containing only devices like PCF8532 and PCF8533. Depending on the application, one must take care of the software commands compatibility and pin connection compatibility.

The $\overline{\text{SYNC}}$ line is provided to maintain the correct synchronization between all cascaded PCF8532's. This synchronization is guaranteed after the power-on reset. The only time that $\overline{\text{SYNC}}$ is likely to be needed is if synchronization is accidentally lost (e.g. by noise in adverse electrical environments, or by the definition of a multiplex mode when PCF8532's with different SA0 levels are cascaded). $\overline{\text{SYNC}}$ is organized as an input/output pin; the output selection being realized as an open-drain driver with an internal pull-up resistor. A PCF8532 asserts the $\overline{\text{SYNC}}$ line at the onset of its last active backplane signal and monitors the $\overline{\text{SYNC}}$ line at all other times. Should synchronization in the cascade be lost, it will be restored by the first PCF8532 to assert $\overline{\text{SYNC}}$. The timing relationship between the backplane waveforms and the $\overline{\text{SYNC}}$ signal for the various drive modes of the PCF8532 are shown in [Figure 23](#).

When using an external clock signal with high frequencies ($f_{\text{clk(Ext)}} > 4 \text{ kHz}$) it is recommended to have an external pull-up resistor between pin $\overline{\text{SYNC}}$ and pin V_{DD} (see [Table 18](#)). This resistor should be present even when no cascading configuration is used! When using it in a cascaded configuration, care must be taken not to route the $\overline{\text{SYNC}}$ signal to close to noisy signals.

The contact resistance between the $\overline{\text{SYNC}}$ pads of cascaded devices must be controlled. If the resistance is too high, the device will not be able to synchronize properly. This is particularly applicable to COG applications. [Table 19](#) shows the limiting values for contact resistance.

In the cascaded applications, the OSC pin of the PCF8532 with subaddress 0 is connected to V_{SS} so that this device uses its internal clock to generate a clock signal at the CLK pin. The other PCF8532 devices are having the OSC pin connected to V_{DD} , meaning that this devices are ready to receive external clock, the signal being provided by the device with subaddress 0.

In the case that the master is providing the clock signal to the slave devices, care must be taken that the sending of display enable or disable will be received by both, the master and the slaves at the same time. When the display is disabled the output from pin CLK is disabled too. The disconnection of the clock may result in a DC component for the display.

Alternatively the schematic can be also constructed such that all the devices have OSC pin connected to V_{DD} and thus an external CLK being provided for the system (all devices connected to the same external CLK).

A configuration where $\overline{\text{SYNC}}$ is connected but all PCF8532 are using the internal clock (OSC pin tied to V_{SS}) is not recommended and may lead to display artefacts!

Table 19. $\overline{\text{SYNC}}$ contact resistance

Number of devices	Maximum contact resistance
2	6000 Ω
3 to 5	2200 Ω
6 to 8	1200 Ω

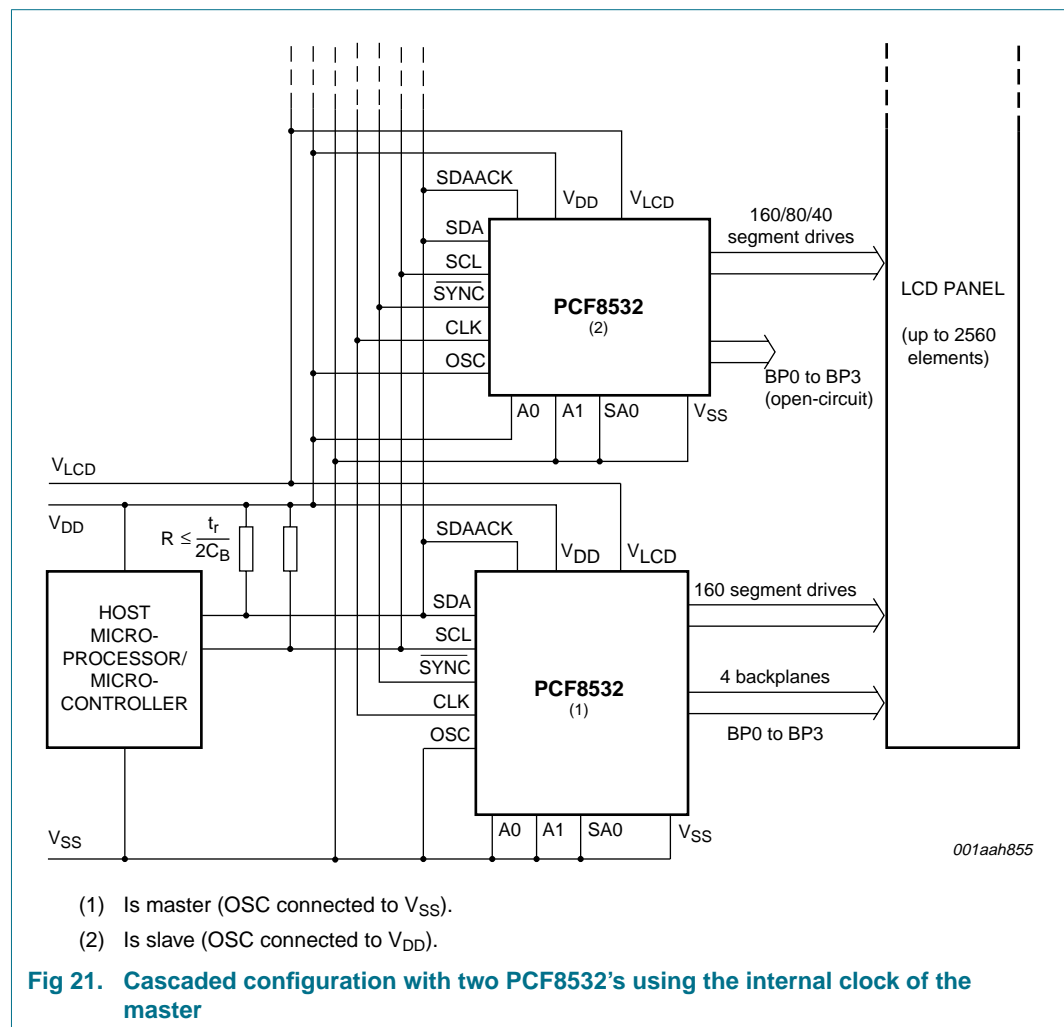

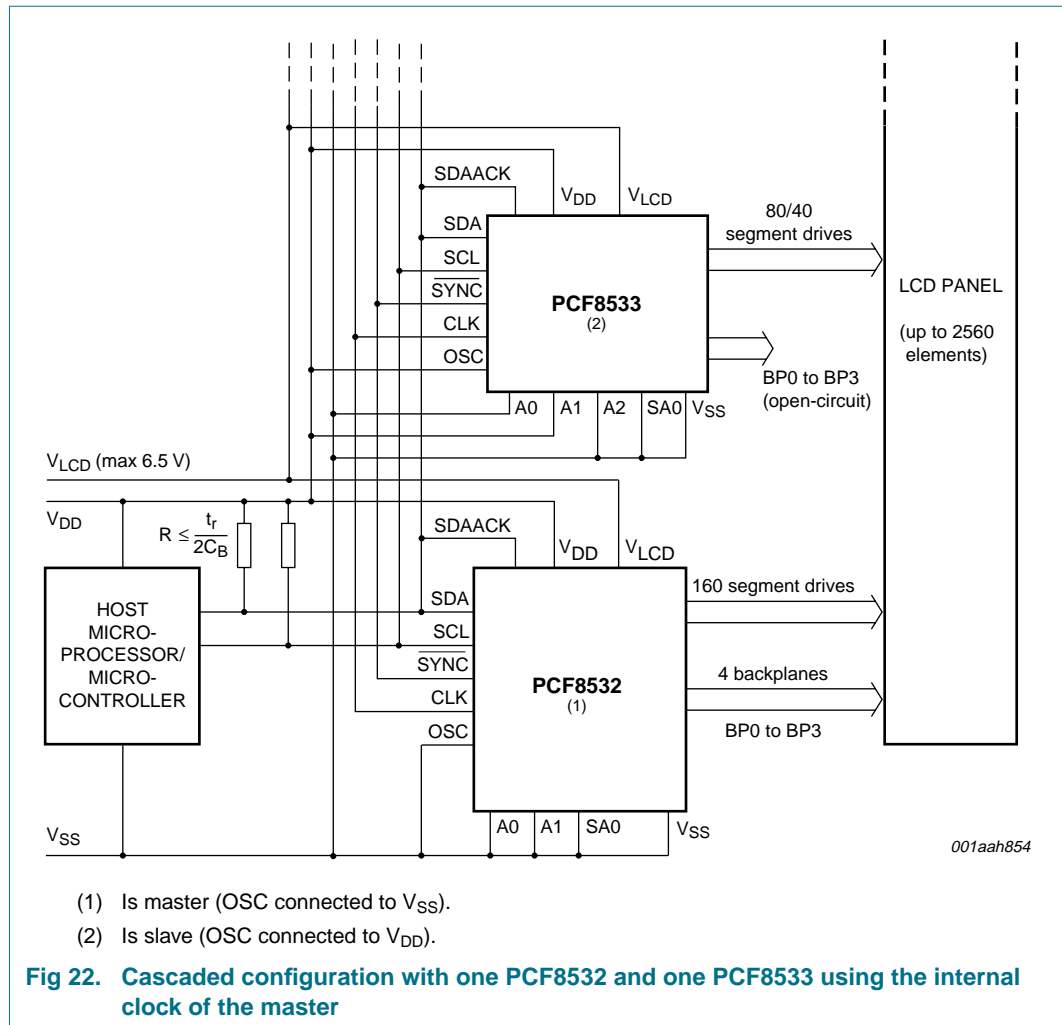

001aah854

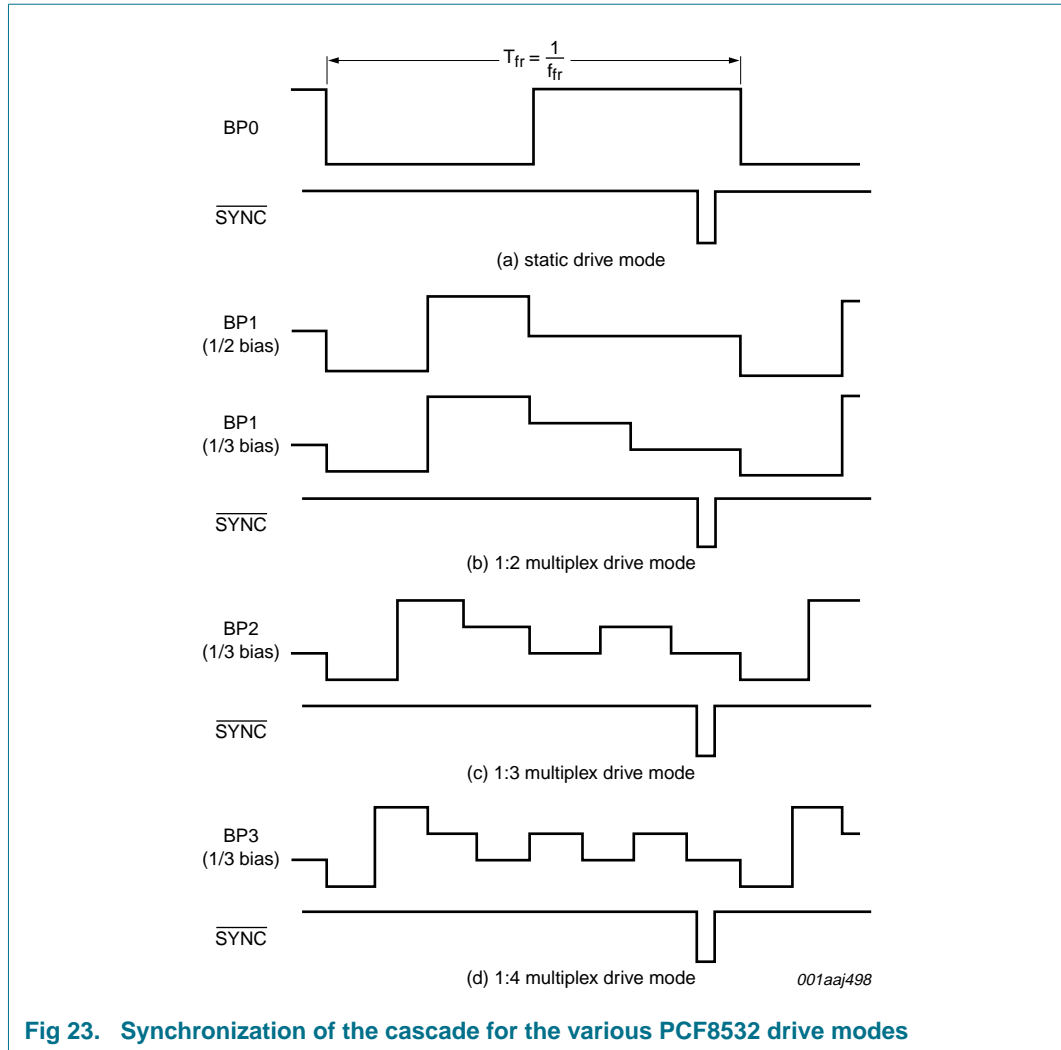

Fig 23. Synchronization of the cascade for the various PCF8532 drive modes

13. Bare die outline

Bare die; 197 bumps; 6.5 x 1.16 x 0.38 mm

PCF8532U

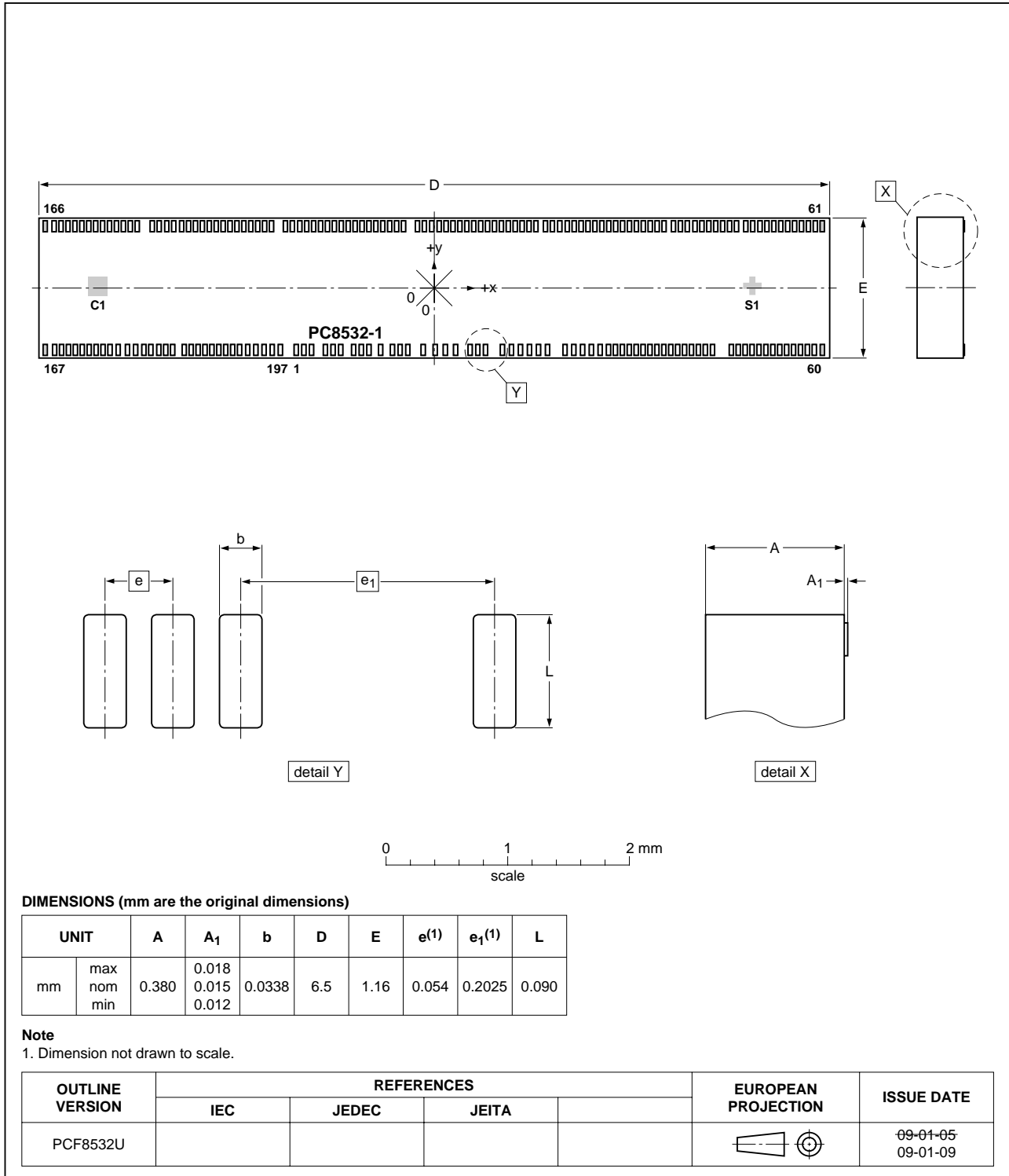

Fig 24. Bare die outline of PCF8532U

Table 20. Pin locations

Symbol	Pad	X (μm)	Y (μm)	Symbol	Pad	X (μm)	Y (μm)
SDAACK	1	-1165.3	-481.5	S68	100	750.2	481.5
SDAACK	2	-1111.3	-481.5	S69	101	696.2	481.5
SDAACK	3	-1057.3	-481.5	S70	102	642.2	481.5
SDA	4	-854.8	-481.5	S71	103	588.2	481.5
SDA	5	-800.8	-481.5	S72	104	534.2	481.5
SDA	6	-746.8	-481.5	S73	105	480.2	481.5
SCL	7	-575.8	-481.5	S74	106	426.2	481.5
SCL	8	-521.8	-481.5	S75	107	372.2	481.5
SCL	9	-467.8	-481.5	S76	108	318.2	481.5
CLK	10	-316.2	-481.5	S77	109	264.2	481.5
V _{DD}	11	-204.1	-481.5	S78	110	210.2	481.5
V _{DD}	12	-150.1	-481.5	S79	111	156.2	481.5
V _{DD}	13	-96.1	-481.5	BP0	112	86.8	481.5
SYNC	14	6.9	-481.5	BP2	113	32.8	481.5
OSC	15	119.4	-481.5	BP1	114	-21.2	481.5
T1	16	203.1	-481.5	BP3	115	-75.2	481.5
T2	17	286.8	-481.5	S80	116	-190.7	481.5
T3	18	389.9	-481.5	S81	117	-244.7	481.5
T3	19	443.9	-481.5	S82	118	-298.7	481.5
T3	20	497.9	-481.5	S83	119	-352.7	481.5
A0	21	640.5	-481.5	S84	120	-406.7	481.5
A1	22	724.2	-481.5	S85	121	-460.7	481.5
SA0	23	807.9	-481.5	S86	122	-514.7	481.5
V _{SS}	24	893.0	-481.5	S87	123	-568.7	481.5
V _{SS}	25	947.0	-481.5	S88	124	-622.7	481.5
V _{SS}	26	1001.0	-481.5	S89	125	-676.7	481.5
V _{LCD}	27	1107.2	-481.5	S90	126	-730.7	481.5
V _{LCD}	28	1161.2	-481.5	S91	127	-784.7	481.5
V _{LCD}	29	1215.2	-481.5	S92	128	-838.7	481.5
BP2	30	1303.4	-481.5	S93	129	-892.7	481.5
BP0	31	1357.4	-481.5	S94	130	-946.7	481.5
S0	32	1411.4	-481.5	S95	131	-1000.7	481.5
S1	33	1465.4	-481.5	S96	132	-1054.7	481.5
S2	34	1519.4	-481.5	S97	133	-1108.7	481.5
S3	35	1573.4	-481.5	S98	134	-1224.2	481.5
S4	36	1627.4	-481.5	S99	135	-1278.2	481.5
S5	37	1681.4	-481.5	S100	136	-1332.2	481.5
S6	38	1735.4	-481.5	S101	137	-1386.2	481.5
S7	39	1789.4	-481.5	S102	138	-1440.2	481.5
S8	40	1843.4	-481.5	S103	139	-1494.2	481.5
S9	41	1897.4	-481.5	S104	140	-1548.2	481.5

Table 20. Pin locations

Symbol	Pad	X (μm)	Y (μm)	Symbol	Pad	X (μm)	Y (μm)
S10	42	1951.4	-481.5	S105	141	-1602.2	481.5
S11	43	2005.4	-481.5	S106	142	-1656.2	481.5
S12	44	2059.4	-481.5	S107	143	-1710.2	481.5
S13	45	2113.4	-481.5	S108	144	-1764.2	481.5
S14	46	2167.4	-481.5	S109	145	-1818.2	481.5
S15	47	2221.4	-481.5	S110	146	-1872.2	481.5
S16	48	2263.9	-481.5	S111	147	-1926.2	481.5
S17	49	2317.9	-481.5	S112	148	-1980.2	481.5
S18	50	2371.9	-481.5	S113	149	-2034.2	481.5
S19	51	2425.9	-481.5	S114	150	-2088.2	481.5
S20	52	2479.9	-481.5	S115	151	-2142.2	481.5
S21	53	2533.9	-481.5	S116	152	-2196.2	481.5
S22	54	2587.9	-481.5	S117	153	-2250.2	481.5
S23	55	2641.9	-481.5	S118	154	-2304.2	481.5
S24	56	2695.9	-481.5	S119	155	-2358.2	481.5
S25	57	2749.9	-481.5	S120	156	-2412.2	481.5
S26	58	2803.9	-481.5	S121	157	-2466.2	481.5
S27	59	2857.9	-481.5	S122	158	-2520.2	481.5
S28	60	2911.9	-481.5	S123	159	-2574.2	481.5
S29	61	2965.9	481.5	S124	160	-2628.2	481.5
S30	62	3019.9	481.5	S125	161	-2682.2	481.5
S31	63	3073.9	481.5	S126	162	-2736.2	481.5
S32	64	3127.9	481.5	S127	163	-2790.2	481.5
S33	65	3181.9	481.5	S128	164	-2844.2	481.5
S34	66	3235.9	481.5	S129	165	-2898.2	481.5
S35	67	3289.9	481.5	S130	166	-2952.2	481.5
S36	68	3343.9	481.5	S131	167	-3006.2	-481.5
S37	69	3397.9	481.5	S132	168	-3060.2	-481.5
S38	70	3451.9	481.5	S133	169	-3114.2	-481.5
S39	71	3505.9	481.5	S134	170	-3168.2	-481.5
S40	72	3559.9	481.5	S135	171	-3222.2	-481.5
S41	73	3613.9	481.5	S136	172	-3276.2	-481.5
S42	74	3667.9	481.5	S137	173	-3330.2	-481.5
S43	75	3721.9	481.5	S138	174	-3384.2	-481.5
S44	76	3775.9	481.5	S139	175	-3438.2	-481.5
S45	77	3829.9	481.5	S140	176	-3492.2	-481.5
S46	78	3883.9	481.5	S141	177	-3546.2	-481.5
S47	79	3937.9	481.5	S142	178	-3600.2	-481.5
S48	80	3991.9	481.5	S143	179	-3654.2	-481.5
S49	81	4045.9	481.5	S144	180	-3708.2	-481.5
S50	82	4099.9	481.5	S145	181	-3762.2	-481.5

Table 20. Pin locations

Symbol	Pad	X (μm)	Y (μm)	Symbol	Pad	X (μm)	Y (μm)
S51	83	1729.7	481.5	S146	182	-2126.7	-481.5
S52	84	1675.7	481.5	S147	183	-2072.7	-481.5
S53	85	1621.7	481.5	S148	184	-2018.7	-481.5
S54	86	1567.7	481.5	S149	185	-1964.7	-481.5
S55	87	1513.7	481.5	S150	186	-1910.7	-481.5
S56	88	1459.7	481.5	S151	187	-1856.7	-481.5
S57	89	1405.7	481.5	S152	188	-1802.7	-481.5
S58	90	1351.7	481.5	S153	189	-1748.7	-481.5
S59	91	1297.7	481.5	S154	190	-1694.7	-481.5
S60	92	1243.7	481.5	S155	191	-1640.7	-481.5
S61	93	1189.7	481.5	S156	192	-1586.7	-481.5
S62	94	1135.7	481.5	S157	193	-1532.7	-481.5
S63	95	1081.7	481.5	S158	194	-1478.7	-481.5
S64	96	1027.7	481.5	S159	195	-1424.7	-481.5
S65	97	973.7	481.5	BP3	196	-1370.7	-481.5
S66	98	858.2	481.5	BP1	197	-1316.7	-481.5
S67	99	804.2	481.5	-	-	-	-

The dummy pads are connected to the segments shown (see [Table 21](#)) but are not tested.

Table 21. Dummy pads

Symbol	Connected to pin	X (μm)	Y (μm)
D1	S131	-3079.2	-481.5
D2	S28	3065.9	-481.5
D3	S29	3121.7	481.5
D4	S130	-3094.7	481.5

The alignment marks are shown in [Table 22](#).

Table 22. Alignment marks

Symbol	Size (μm)	X (μm)	Y (μm)
S1	121.5 × 121.5	-2733.75	-47.25
C1	121.5 × 121.5	2603.7	-47.25

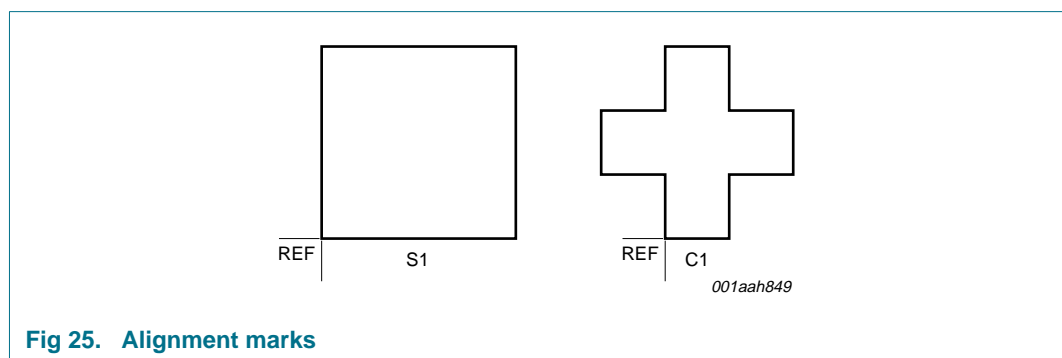
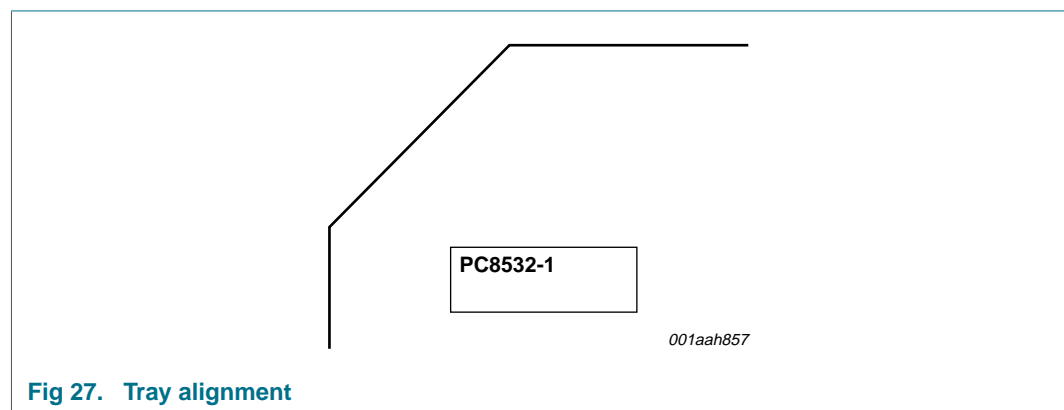
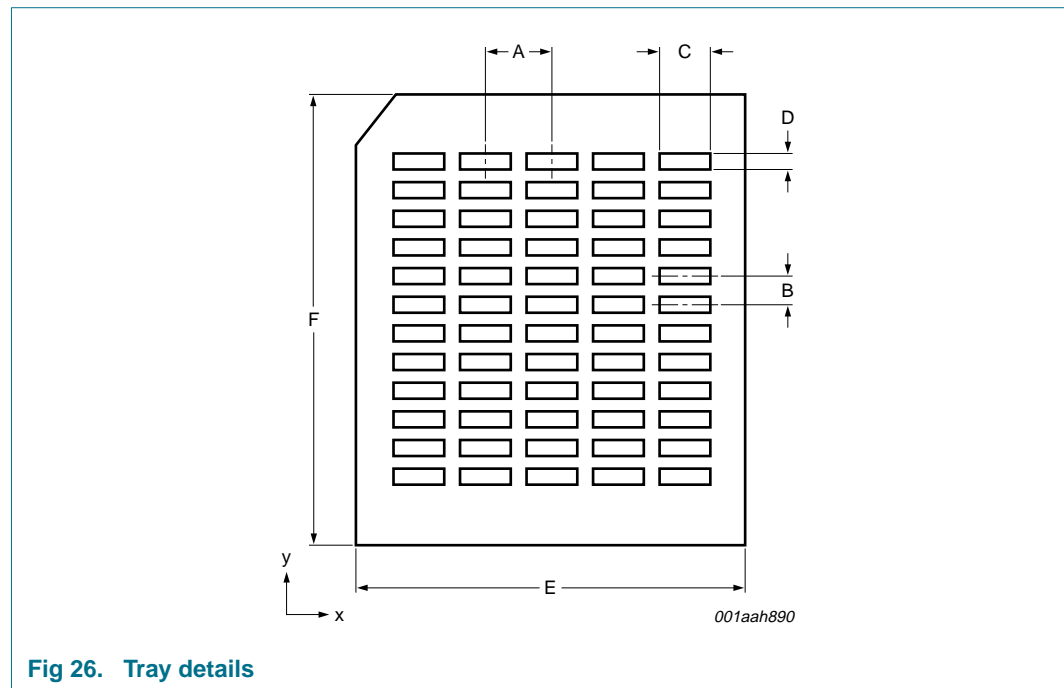

Fig 25. Alignment marks

14. Packing information

Table 23. Tray dimensions (see Figure 26)

Symbol	Description	Value
A	pocket pitch in x direction	8.8 mm
B	pocket pitch in y direction	3.6 mm
C	pocket width in x direction	6.65 mm
D	pocket width in y direction	1.31 mm
E	tray width in x direction	50.8 mm
F	tray width in y direction	50.8 mm
x	number of pockets, x direction	5
y	number of pockets, y direction	12



15. Abbreviations

Table 24. Abbreviations

Acronym	Description
CMOS	Complementary Metal Oxide Semiconductor
COG	Chip-On-Glass
HBM	Human Body Model
I ² C	Inter-Integrated Circuit
ITO	Indium Tin Oxide
LCD	Liquid Crystal Display
LSB	Least Significant Bit
MM	Machine Model
MSB	Most Significant Bit
RAM	Random Access Memory
RMS	Root Mean Square

16. Revision history

Table 25. Revision history

Document ID	Release date	Data sheet status	Change notice	Supersedes
PCF8532_1	20090210	Product data sheet	-	-

17. Legal information

17.1 Data sheet status

Document status ^{[1][2]}	Product status ^[3]	Definition
Objective [short] data sheet	Development	This document contains data from the objective specification for product development.
Preliminary [short] data sheet	Qualification	This document contains data from the preliminary specification.
Product [short] data sheet	Production	This document contains the product specification.

[1] Please consult the most recently issued document before initiating or completing a design.

[2] The term 'short data sheet' is explained in section "Definitions".

[3] The product status of device(s) described in this document may have changed since this document was published and may differ in case of multiple devices. The latest product status information is available on the Internet at URL <http://www.nxp.com>.

17.2 Definitions

Draft — The document is a draft version only. The content is still under internal review and subject to formal approval, which may result in modifications or additions. NXP Semiconductors does not give any representations or warranties as to the accuracy or completeness of information included herein and shall have no liability for the consequences of use of such information.

Short data sheet — A short data sheet is an extract from a full data sheet with the same product type number(s) and title. A short data sheet is intended for quick reference only and should not be relied upon to contain detailed and full information. For detailed and full information see the relevant full data sheet, which is available on request via the local NXP Semiconductors sales office. In case of any inconsistency or conflict with the short data sheet, the full data sheet shall prevail.

17.3 Disclaimers

General — Information in this document is believed to be accurate and reliable. However, NXP Semiconductors does not give any representations or warranties, expressed or implied, as to the accuracy or completeness of such information and shall have no liability for the consequences of use of such information.

Right to make changes — NXP Semiconductors reserves the right to make changes to information published in this document, including without limitation specifications and product descriptions, at any time and without notice. This document supersedes and replaces all information supplied prior to the publication hereof.

Suitability for use — NXP Semiconductors products are not designed, authorized or warranted to be suitable for use in medical, military, aircraft, space or life support equipment, nor in applications where failure or malfunction of an NXP Semiconductors product can reasonably be expected to result in personal injury, death or severe property or environmental damage. NXP Semiconductors accepts no liability for inclusion and/or use of NXP Semiconductors products in such equipment or applications and therefore such inclusion and/or use is at the customer's own risk.

Applications — Applications that are described herein for any of these products are for illustrative purposes only. NXP Semiconductors makes no representation or warranty that such applications will be suitable for the specified use without further testing or modification.

Limiting values — Stress above one or more limiting values (as defined in the Absolute Maximum Ratings System of IEC 60134) may cause permanent damage to the device. Limiting values are stress ratings only and operation of the device at these or any other conditions above those given in the Characteristics sections of this document is not implied. Exposure to limiting values for extended periods may affect device reliability.

Terms and conditions of sale — NXP Semiconductors products are sold subject to the general terms and conditions of commercial sale, as published at <http://www.nxp.com/profile/terms>, including those pertaining to warranty, intellectual property rights infringement and limitation of liability, unless explicitly otherwise agreed to in writing by NXP Semiconductors. In case of any inconsistency or conflict between information in this document and such terms and conditions, the latter will prevail.

No offer to sell or license — Nothing in this document may be interpreted or construed as an offer to sell products that is open for acceptance or the grant, conveyance or implication of any license under any copyrights, patents or other industrial or intellectual property rights.

Bare die — All die are tested on compliance with their related technical specifications as stated in this data sheet up to the point of wafer sawing and are handled in accordance with the NXP Semiconductors storage and transportation conditions. If there are data sheet limits not guaranteed, these will be separately indicated in the data sheet. There are no post-packing tests performed on individual die or wafers.

NXP Semiconductors has no control of third party procedures in the sawing, handling, packing or assembly of the die. Accordingly, NXP Semiconductors assumes no liability for device functionality or performance of the die or systems after third party sawing, handling, packing or assembly of the die. It is the responsibility of the customer to test and qualify their application in which the die is used.

All die sales are conditioned upon and subject to the customer entering into a written die sale agreement with NXP Semiconductors through its legal department.

17.4 Trademarks

Notice: All referenced brands, product names, service names and trademarks are the property of their respective owners.

I²C-bus — logo is a trademark of NXP B.V.

18. Contact information

For more information, please visit: <http://www.nxp.com>

For sales office addresses, please send an email to: salesaddresses@nxp.com

19. Contents

1	General description	1	13	Bare die outline	36
2	Features	1	14	Packing information	40
3	Ordering information	2	15	Abbreviations	41
4	Marking	2	16	Revision history	42
5	Block diagram	2	17	Legal information	43
6	Pinning information	3	17.1	Data sheet status	43
6.1	Pinning	3	17.2	Definitions	43
6.2	Pin description	4	17.3	Disclaimers	43
7	Functional description	4	17.4	Trademarks	43
7.1	Power-on reset	5	18	Contact information	43
7.2	LCD bias generator	5	19	Contents	44
7.3	LCD voltage selector	6			
7.4	LCD drive mode waveforms	8			
7.4.1	Static drive mode	8			
7.4.2	1:2 multiplex drive mode	9			
7.4.3	1:3 multiplex drive mode	11			
7.4.4	1:4 multiplex drive mode	12			
7.5	Oscillator	13			
7.5.1	Internal clock	13			
7.5.2	External clock	13			
7.6	Timing and frame frequency	13			
7.7	Display register	13			
7.8	Segment outputs	13			
7.9	Backplane outputs	14			
7.10	Display RAM	14			
7.11	Data pointer	15			
7.12	Subaddress counter	17			
7.13	Output bank selector	17			
7.14	Input bank selector	17			
7.15	Blinker	18			
7.16	Characteristics of the I ² C-bus	18			
7.16.1	Bit transfer	19			
7.16.2	START and STOP conditions	19			
7.16.3	System configuration	19			
7.16.4	Acknowledge	20			
7.16.5	I ² C-bus controller	20			
7.16.6	Input filters	21			
7.16.7	I ² C-bus protocol	21			
7.17	Command decoder	22			
7.18	Display controller	25			
8	Internal circuitry	26			
9	Limiting values	27			
10	Static characteristics	28			
11	Dynamic characteristics	30			
12	Application information	32			
12.1	Cascaded operation	32			

Please be aware that important notices concerning this document and the product(s) described herein, have been included in section 'Legal information'.



© NXP B.V. 2009.

All rights reserved.

For more information, please visit: <http://www.nxp.com>

For sales office addresses, please send an email to: salesaddresses@nxp.com

Date of release: 10 February 2009

Document identifier: PCF8532_1