

PIC18F8723 Family Data Sheet

64/80-Pin, 1-Mbit,
Enhanced Flash Microcontrollers
with 12-Bit A/D and nanoWatt Technology

Note the following details of the code protection feature on Microchip devices:

- Microchip products meet the specification contained in their particular Microchip Data Sheet.
- Microchip believes that its family of products is one of the most secure families of its kind on the market today, when used in the intended manner and under normal conditions.
- There are dishonest and possibly illegal methods used to breach the code protection feature. All of these methods, to our knowledge, require using the Microchip products in a manner outside the operating specifications contained in Microchip's Data Sheets. Most likely, the person doing so is engaged in theft of intellectual property.
- Microchip is willing to work with the customer who is concerned about the integrity of their code.
- Neither Microchip nor any other semiconductor manufacturer can guarantee the security of their code. Code protection does not mean that we are guaranteeing the product as "unbreakable."

Code protection is constantly evolving. We at Microchip are committed to continuously improving the code protection features of our products. Attempts to break Microchip's code protection feature may be a violation of the Digital Millennium Copyright Act. If such acts allow unauthorized access to your software or other copyrighted work, you may have a right to sue for relief under that Act.

Information contained in this publication regarding device applications and the like is provided only for your convenience and may be superseded by updates. It is your responsibility to ensure that your application meets with your specifications. MICROCHIP MAKES NO REPRESENTATIONS OR WARRANTIES OF ANY KIND WHETHER EXPRESS OR IMPLIED, WRITTEN OR ORAL, STATUTORY OR OTHERWISE, RELATED TO THE INFORMATION, INCLUDING BUT NOT LIMITED TO ITS CONDITION, QUALITY, PERFORMANCE, MERCHANTABILITY OR FITNESS FOR PURPOSE. Microchip disclaims all liability arising from this information and its use. Use of Microchip devices in life support and/or safety applications is entirely at the buyer's risk, and the buyer agrees to defend, indemnify and hold harmless Microchip from any and all damages, claims, suits, or expenses resulting from such use. No licenses are conveyed, implicitly or otherwise, under any Microchip intellectual property rights.

Trademarks

The Microchip name and logo, the Microchip logo, dsPIC, KEELOQ, KEELOQ logo, MPLAB, PIC, PICmicro, PICSTART, rPIC and UNI/O are registered trademarks of Microchip Technology Incorporated in the U.S.A. and other countries.

FilterLab, Hampshire, HI-TECH C, Linear Active Thermistor, MXDEV, MXLAB, SEEVAL and The Embedded Control Solutions Company are registered trademarks of Microchip Technology Incorporated in the U.S.A.

Analog-for-the-Digital Age, Application Maestro, CodeGuard, dsPICDEM, dsPICDEM.net, dsPICworks, dsSPEAK, ECAN, ECONOMONITOR, FanSense, HI-TIDE, In-Circuit Serial Programming, ICSP, Mindi, MiWi, MPASM, MPLAB Certified logo, MPLIB, MPLINK, mTouch, Octopus, Omniscient Code Generation, PICC, PICC-18, PICDEM, PICDEM.net, PICKit, PICtail, PIC³² logo, REAL ICE, rLAB, Select Mode, Total Endurance, TSHARC, UniWinDriver, WiperLock and ZENA are trademarks of Microchip Technology Incorporated in the U.S.A. and other countries.

SQTP is a service mark of Microchip Technology Incorporated in the U.S.A.

All other trademarks mentioned herein are property of their respective companies.

© 2009, Microchip Technology Incorporated, Printed in the U.S.A., All Rights Reserved.

 Printed on recycled paper.

QUALITY MANAGEMENT SYSTEM
CERTIFIED BY DNV
== ISO/TS 16949:2002 ==

Microchip received ISO/TS-16949:2002 certification for its worldwide headquarters, design and wafer fabrication facilities in Chandler and Tempe, Arizona; Gresham, Oregon and design centers in California and India. The Company's quality system processes and procedures are for its PIC[®] MCUs and dsPIC[®] DSCs, KEELOQ[®] code hopping devices, Serial EEPROMs, microperipherals, nonvolatile memory and analog products. In addition, Microchip's quality system for the design and manufacture of development systems is ISO 9001:2000 certified.

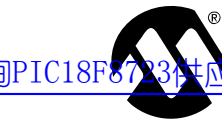

MICROCHIP

PIC18F8723 FAMILY

64/80-Pin, 1-Mbit, Enhanced Flash Microcontrollers with 12-Bit A/D and nanoWatt Technology

Peripheral Highlights:

- 12-Bit, Up to 16-Channel Analog-to-Digital Converter module (A/D):
 - Auto-acquisition capability
 - Conversion available during Sleep
- Two Master Synchronous Serial Port (MSSP) modules supporting 2/3/4-Wire SPI (all four modes) and I²C™ Master and Slave modes
- Two Capture/Compare/PWM (CCP) modules
- Three Enhanced Capture/Compare/PWM (ECCP) modules:
 - One, two or four PWM outputs
 - Selectable polarity
 - Programmable dead time
 - Auto-shutdown and auto-restart
- Two Enhanced Addressable USART modules:
 - Supports RS-485, RS-232 and LIN 1.2
 - Auto-wake-up on Start bit
 - Auto-Baud Detect
- Dual Analog Comparators with Input Multiplexing
- High-Current Sink/Source 25 mA/25 mA
- Four Programmable External Interrupts
- Four Input Change Interrupts

External Memory Interface:

- Address Capability of Up to 2 Mbytes
- 8-Bit or 16-Bit Interface
- 8, 12, 16 and 20-Bit Address modes

Power-Managed Modes:

- Run: CPU on, Peripherals on
- Idle: CPU off, Peripherals on
- Sleep: CPU off, Peripherals off
- Idle mode Currents Down to 15 µA Typical
- Sleep Current Down to 0.2 µA Typical
- Timer1 Oscillator: 1.8 µA, 32 kHz, 2V
- Watchdog Timer: 2.1 µA

Special Microcontroller Features:

- C Compiler Optimized Architecture:
 - Optional extended instruction set designed to optimize re-entrant code
- 100,000 Erase/Write Cycle Enhanced Flash Program Memory Typical
- 1,000,000 Erase/Write Cycle Data EEPROM Memory Typical
- Flash/Data EEPROM Retention: 100 Years Typical
- Self-Programmable under Software Control
- Priority Levels for Interrupts
- 8 x 8 Single-Cycle Hardware Multiplier
- Extended Watchdog Timer (WDT):
 - Programmable period from 4 ms to 131s
- Single-Supply In-Circuit Serial Programming™ (ICSP™) via Two Pins
- In-Circuit Debug (ICD) via Two Pins
- Wide Operating Voltage Range: 2.0V to 5.5V
- Fail-Safe Clock Monitor
- Two-Speed Oscillator Start-up
- nanoWatt Technology

Note: This document is supplemented by the "PIC18F8722 Family Data Sheet" (DS39646). See **Section 1.0 "Device Overview"**.

Device	Program Memory		Data Memory		I/O	12-Bit A/D (ch)	CCP/ECCP (PWM)	MSSP		EUSART	Comparators	Timers 8/16-Bit	External Bus	
	Flash (bytes)	# Single-Word Instructions	SRAM (bytes)	EEPROM (bytes)				SPI	Master I ² C™					
PIC18F6628	96K	49152	3936	1024	54	12	2/3	2	Y	Y	2	2	2/3	N
PIC18F6723	128K	65536	3936	1024	54	12	2/3	2	Y	Y	2	2	2/3	N
PIC18F8628	96K	49152	3936	1024	70	16	2/3	2	Y	Y	2	2	2/3	Y
PIC18F8723	128K	65536	3936	1024	70	16	2/3	2	Y	Y	2	2	2/3	Y

PIC18F8723

[查询PIC18F8723供应商](#)

Pin Diagrams

64-Pin TQFP

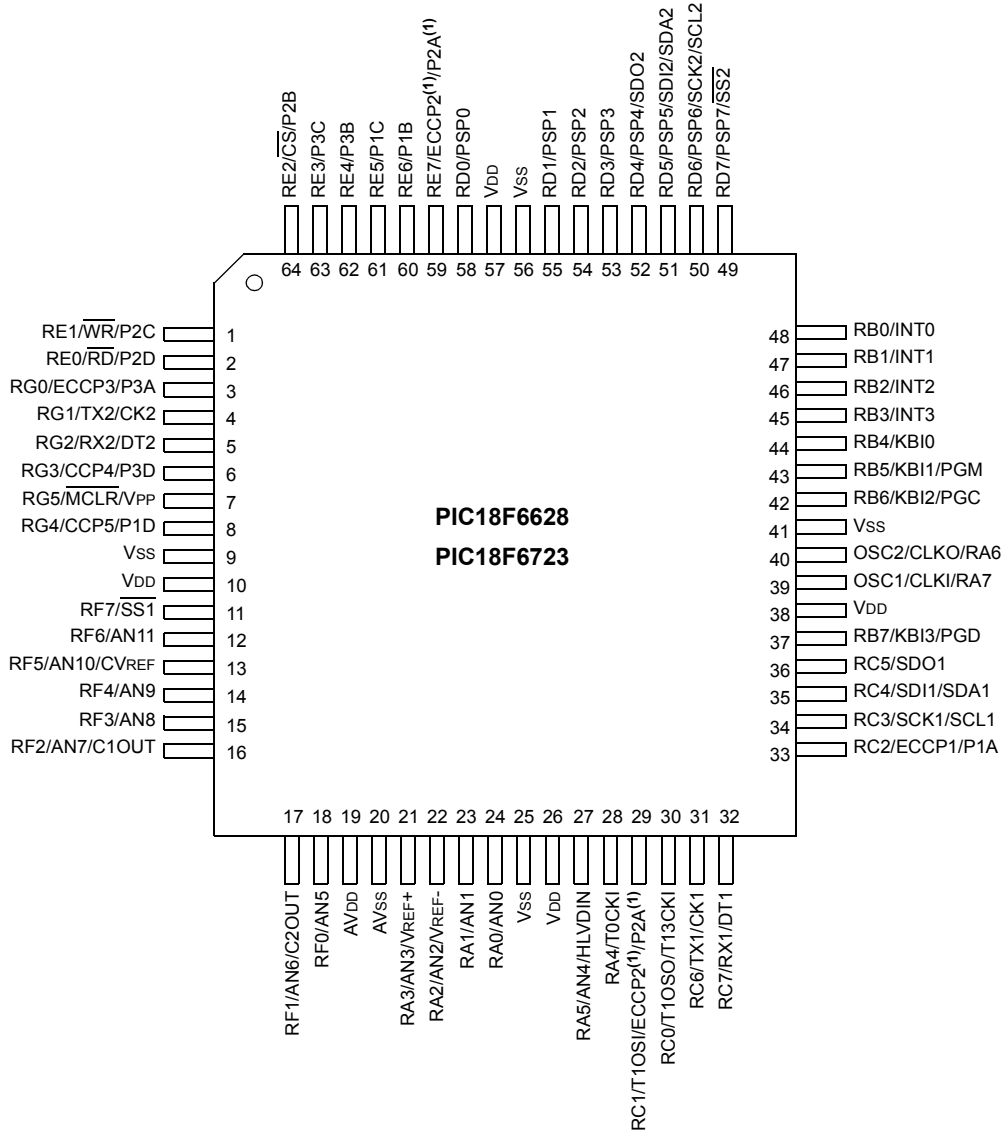

Note 1: The ECCP2/P2A pin placement is determined by the CCP2MX Configuration bit.

Pin Diagrams (Continued)

80-Pin TQFP

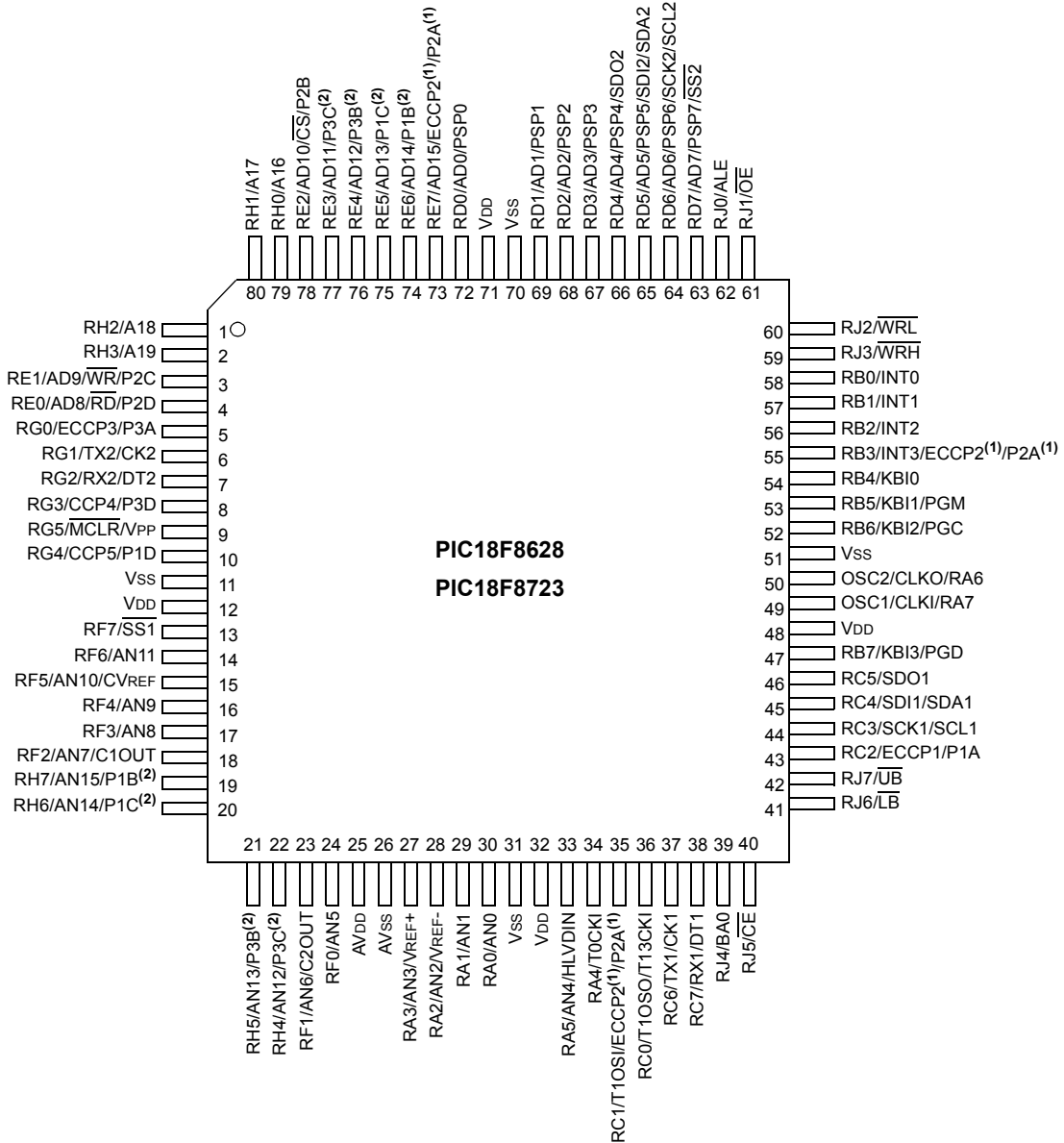

Note 1: The ECCP2/P2A pin placement is determined by the CCP2MX Configuration bit and Processor mode settings.
Note 2: P1B, P1C, P3B and P3C pin placement is determined by the ECCPMX Configuration bit.

PIC18F8723

[查询PIC18F8723供应商](#)

Table of Contents

1.0	Device Overview	9
2.0	12-Bit Analog-to-Digital Converter (A/D) Module	31
3.0	Special Features of the CPU	41
4.0	Electrical Characteristics	43
5.0	Packaging Information.....	49
	Appendix A: Revision History.....	51
	Appendix B: Device Differences.....	51
	Appendix C: Conversion Considerations	52
	Appendix D: Migration From Baseline to Enhanced Devices.....	52
	Appendix E: Migration From Mid-Range to Enhanced Devices	53
	Appendix F: Migration From High-End to Enhanced Devices	53
	Index	55
	The Microchip Web Site	57
	Customer Change Notification Service	57
	Customer Support	57
	Reader Response	58
	PIC18F8723 family Product Identification System	59

TO OUR VALUED CUSTOMERS

It is our intention to provide our valued customers with the best documentation possible to ensure successful use of your Microchip products. To this end, we will continue to improve our publications to better suit your needs. Our publications will be refined and enhanced as new volumes and updates are introduced.

If you have any questions or comments regarding this publication, please contact the Marketing Communications Department via E-mail at docerrors@microchip.com or fax the **Reader Response Form** in the back of this data sheet to (480) 792-4150. We welcome your feedback.

Most Current Data Sheet

To obtain the most up-to-date version of this data sheet, please register at our Worldwide Web site at:

<http://www.microchip.com>

You can determine the version of a data sheet by examining its literature number found on the bottom outside corner of any page. The last character of the literature number is the version number, (e.g., DS30000A is version A of document DS30000).

Errata

An errata sheet, describing minor operational differences from the data sheet and recommended workarounds, may exist for current devices. As device/documentation issues become known to us, we will publish an errata sheet. The errata will specify the revision of silicon and revision of document to which it applies.

To determine if an errata sheet exists for a particular device, please check with one of the following:

- Microchip's Worldwide Web site; <http://www.microchip.com>
- Your local Microchip sales office (see last page)

When contacting a sales office, please specify which device, revision of silicon and data sheet (include literature number) you are using.

Customer Notification System

Register on our web site at www.microchip.com to receive the most current information on all of our products.

PIC18F8723

[查询PIC18F8723供应商](#)

NOTES:

PIC18F8723 FAMILY

[查询PIC18F8723供应商](#)

1.0 DEVICE OVERVIEW

This document contains device-specific information for the following devices:

- PIC18F6628
- PIC18F6723
- PIC18F8628
- PIC18F8723
- PIC18LF6628
- PIC18LF6723
- PIC18LF8628
- PIC18LF8723

Note: This data sheet documents only the devices' features and specifications that are in addition to the features and specifications of the PIC18F8722 family devices. For information on the features and specifications shared by the PIC18F8723 family and PIC18F8722 family devices, see the "*PIC18F8722 Family Data Sheet*" (DS39646).

The PIC18F8723 family of devices offers the advantages of all PIC18 microcontrollers – namely, high computational performance at an economical price – with the addition of high-endurance, Enhanced Flash program memory. In addition to these features, the PIC18F8723 introduces design enhancements that make these microcontrollers a logical choice for many high-performance, power-sensitive applications.

1.1 Special Features

- **12-Bit A/D Converter:** The PIC18F8723 family implements a 12-bit A/D Converter. A/D Converters in both families incorporate programmable acquisition time. This allows for a channel to be selected and a conversion to be initiated, without waiting for a sampling period and thus, reducing code overhead.

1.2 Details on Individual Family Members

Devices in the PIC18F8723 family are available in 64-pin and 80-pin packages. Block diagrams for the two groups are shown in Figure 1-1 and Figure 1-2.

The devices are differentiated from each other in the following ways:

- Flash program memory (96 Kbytes for PIC18FX628 devices and 128 Kbytes for PIC18FX723).
- A/D channels (12 for PIC18F6628/6723 devices and 16 for PIC18F8628/8723 devices).
- I/O ports (seven bidirectional ports on PIC18F6628/6723 devices and nine bidirectional ports on PIC18F8628/8723 devices).
- External Memory Bus, configurable for 8 and 16-bit operation

All other features for devices in this family are identical. These are summarized in Table 1-1.

The pinouts for all devices are listed in Table 1-2 and Table 1-3.

Like all Microchip PIC18 devices, members of the PIC18F8723 family are available as both standard and low-voltage devices. Standard devices with Enhanced Flash memory, designated with an "F" in the part number (such as PIC18F6628), accommodate an operating V_{DD} range of 4.2V to 5.5V. Low-voltage parts, designated by "LF" (such as PIC18LF6628), function over an extended V_{DD} range of 2.0V to 5.5V.

PIC18F8723 FAMILY

[查询PIC18F8723供应商](#)

TABLE 1-1: DEVICE FEATURES

Features	PIC18F6628	PIC18F6723	PIC18F8628	PIC18F8723
Operating Frequency	DC – 40 MHz	DC – 40 MHz	DC – 40 MHz	DC – 40 MHz
Program Memory (Bytes)	96K	128K	96K	128K
Program Memory (Instructions)	49152	65536	49152	65536
Data Memory (Bytes)	3936	3936	3936	3936
Data EEPROM Memory (Bytes)	1024	1024	1024	1024
Interrupt Sources	28	28	29	29
I/O Ports	Ports A, B, C, D, E, F, G	Ports A, B, C, D, E, F, G	Ports A, B, C, D, E, F, G, H, J	Ports A, B, C, D, E, F, G, H, J
Timers	5	5	5	5
Capture/Compare/PWM Modules	2	2	2	2
Enhanced Capture/Compare/PWM Modules	3	3	3	3
Enhanced USART	2	2	2	2
Serial Communications	MSSP, Enhanced USART	MSSP, Enhanced USART	MSSP, Enhanced USART	MSSP, Enhanced USART
Parallel Communications (PSP)	Yes	Yes	Yes	Yes
12-Bit Analog-to-Digital Module	12 Input Channels	12 Input Channels	16 Input Channels	16 Input Channels
Resets (and Delays)	POR, BOR, RESET Instruction, Stack Full, Stack Underflow (PWRT, OST), MCLR (optional), WDT	POR, BOR, RESET Instruction, Stack Full, Stack Underflow (PWRT, OST), MCLR (optional), WDT	POR, BOR, RESET Instruction, Stack Full, Stack Underflow (PWRT, OST), MCLR (optional), WDT	POR, BOR, RESET Instruction, Stack Full, Stack Underflow (PWRT, OST), MCLR (optional), WDT
Programmable High/Low-Voltage Detect	Yes	Yes	Yes	Yes
Programmable Brown-out Reset	Yes	Yes	Yes	Yes
Instruction Set	75 Instructions; 83 with Extended Instruction Set Enabled	75 Instructions; 83 with Extended Instruction Set Enabled	75 Instructions; 83 with Extended Instruction Set Enabled	75 Instructions; 83 with Extended Instruction Set Enabled
Packages	64-Pin TQFP	64-Pin TQFP	80-Pin TQFP	80-Pin TQFP

PIC18F8723 FAMILY

查询PIC18F8723供应商

FIGURE 1-1: PIC18F6628/6723 (64-PIN) BLOCK DIAGRAM

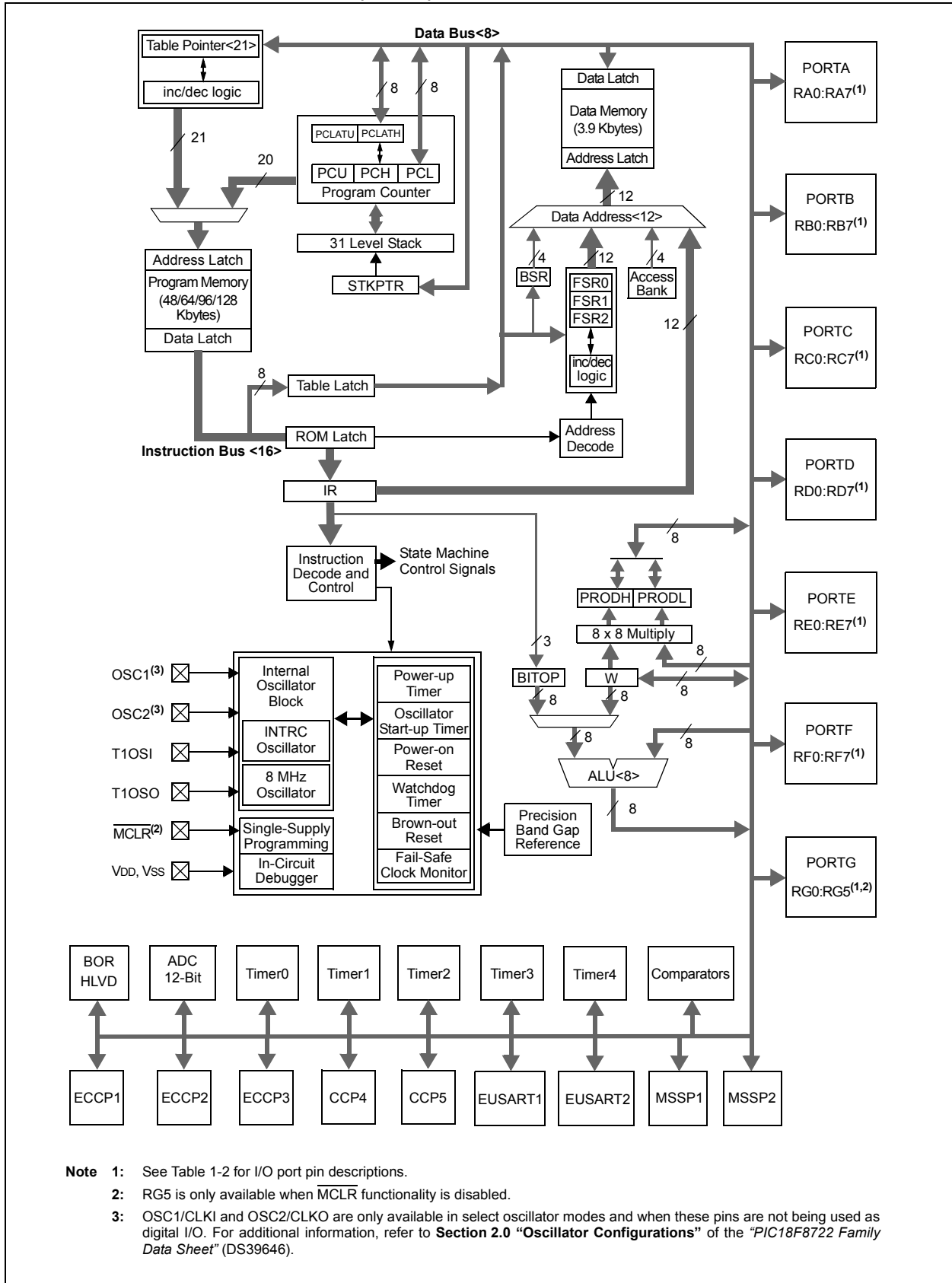

PIC18F8723 FAMILY

查询PIC18F8723供应商

FIGURE 1-2: PIC18F8628/8723 (80-PIN) BLOCK DIAGRAM

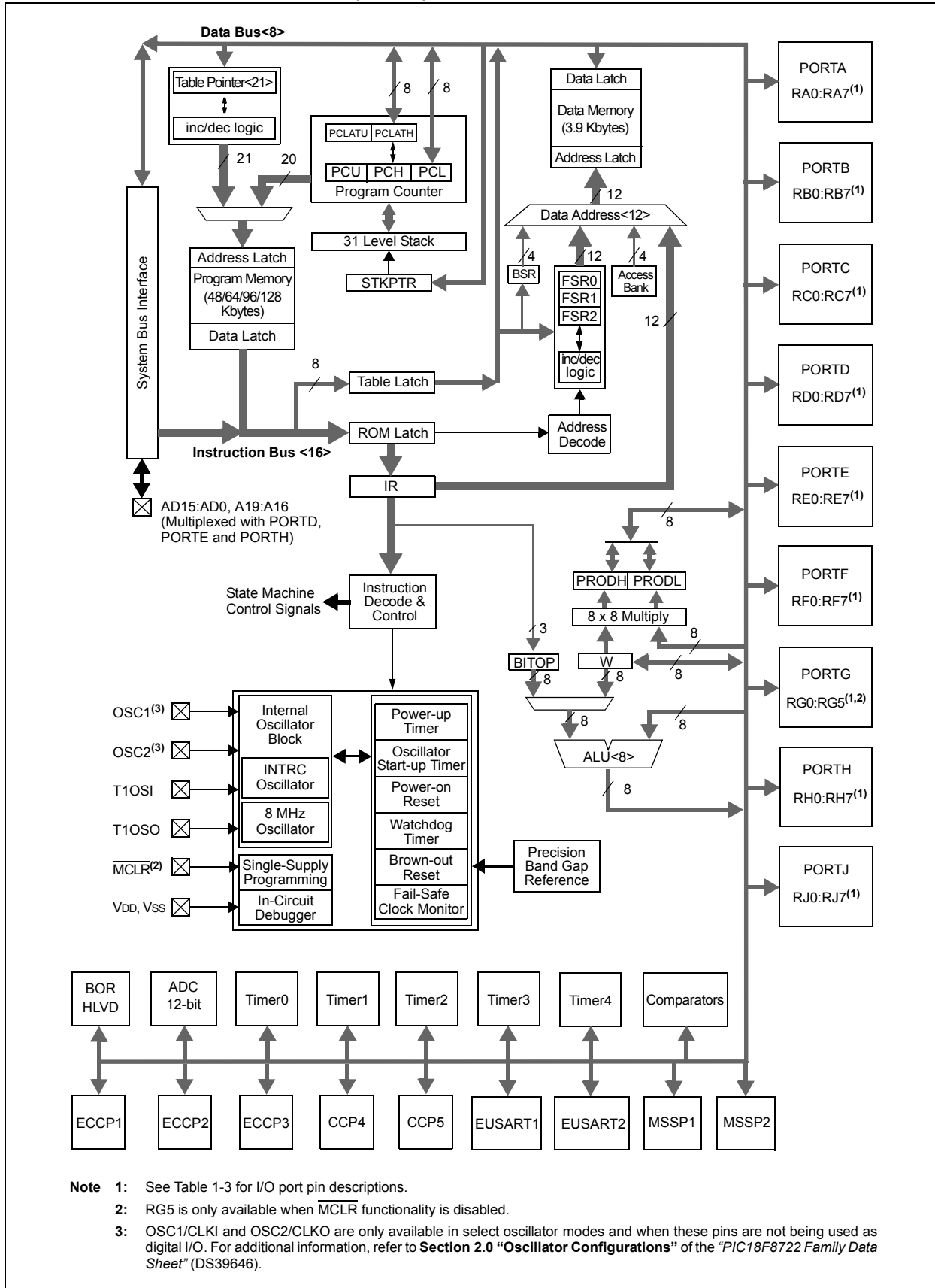

PIC18F8723 FAMILY

[查询PIC18F8723供应商](#)

TABLE 1-2: PIC18F6628/6723 (64-PIN) PINOUT I/O DESCRIPTIONS (CONTINUED)

Pin Name	Pin Number	Pin Type	Buffer Type	Description
	TQFP			
RD0/PSP0 RD0 PSP0	58	I/O I/O	ST TTL	PORTD is a bidirectional I/O port. Digital I/O. Parallel Slave Port data.
RD1/PSP1 RD1 PSP1	55	I/O I/O	ST TTL	Digital I/O. Parallel Slave Port data.
RD2/PSP2 RD2 PSP2	54	I/O I/O	ST TTL	Digital I/O. Parallel Slave Port data.
RD3/PSP3 RD3 PSP3	53	I/O I/O	ST TTL	Digital I/O. Parallel Slave Port data.
RD4/PSP4/SDO2 RD4 PSP4 SDO2	52	I/O I/O O	ST TTL —	Digital I/O. Parallel Slave Port data. SPI data out.
RD5/PSP5/SDI2/ SDA2 RD5 PSP5 SDI2 SDA2	51	I/O I/O I I/O	ST TTL ST I ² C/SMB	Digital I/O. Parallel Slave Port data. SPI data in. I ² C™ data I/O.
RD6/PSP6/SCK2/ SCL2 RD6 PSP6 SCK2 SCL2	50	I/O I/O I/O I/O	ST TTL ST I ² C/SMB	Digital I/O. Parallel Slave Port data. Synchronous serial clock input/output for SPI mode. Synchronous serial clock input/output for I ² C mode.
RD7/PSP7/SS2 RD7 PSP7 SS2	49	I/O I/O I	ST TTL TTL	Digital I/O. Parallel Slave Port data. SPI slave select input.

Legend: TTL = TTL compatible input CMOS = CMOS compatible input or output
 ST = Schmitt Trigger input with CMOS levels Analog = Analog input
 I = Input O = Output
 P = Power I²C™ = I²C/SMBus input buffer

Note 1: Default assignment for ECCP2 when Configuration bit, CCP2MX, is set.
2: Alternate assignment for ECCP2 when Configuration bit, CCP2MX, is cleared.

PIC18F8723 FAMILY

[查询PIC18F8723供应商](#)

TABLE 1-3: PIC18F8628/8723 (80-PIN) PINOUT I/O DESCRIPTIONS (CONTINUED)

Pin Name	Pin Number	Pin Type	Buffer Type	Description
	TQFP			
RB0/INT0/FLT0	58			PORTB is a bidirectional I/O port. PORTB can be software programmed for internal weak pull-ups on all inputs.
RB0		I/O	TTL	Digital I/O.
INT0		I	ST	External interrupt 0.
FLT0		I	ST	PWM Fault input for ECCPx.
RB1/INT1	57			
RB1		I/O	TTL	Digital I/O.
INT1		I	ST	External interrupt 1.
RB2/INT2	56			
RB2		I/O	TTL	Digital I/O.
INT2		I	ST	External interrupt 2.
RB3/INT3/ECCP2/P2A	55			
RB3		I/O	TTL	Digital I/O.
INT3		I	ST	External interrupt 3.
ECCP2 ⁽¹⁾		O	—	Enhanced Capture 2 input/Compare 2 output/ PWM2 output.
P2A ⁽¹⁾		O	—	ECCP2 PWM output A.
RB4/KBI0	54			
RB4		I/O	TTL	Digital I/O.
KBI0		I	TTL	Interrupt-on-change pin.
RB5/KBI1/PGM	53			
RB5		I/O	TTL	Digital I/O.
KBI1		I	TTL	Interrupt-on-change pin.
PGM	I/O	ST	Low-Voltage ICSP™ Programming enable pin.	
RB6/KBI2/PGC	52			
RB6		I/O	TTL	Digital I/O.
KBI2		I	TTL	Interrupt-on-change pin.
PGC	I/O	ST	In-Circuit Debugger and ICSP™ programming clock pin.	
RB7/KBI3/PGD	47			
RB7		I/O	TTL	Digital I/O.
KBI3		I	TTL	Interrupt-on-change pin.
PGD	I/O	ST	In-Circuit Debugger and ICSP programming data pin.	

Legend: TTL = TTL compatible input CMOS = CMOS compatible input or output
 ST = Schmitt Trigger input with CMOS levels Analog = Analog input
 I = Input O = Output
 P = Power I²C™/SMB = I²C/SMBus input buffer

- Note 1:** Alternate assignment for ECCP2 when Configuration bit, CCP2MX, is cleared (all operating modes except Microcontroller mode).
- 2:** Default assignment for ECCP2 in all operating modes (CCP2MX is set).
- 3:** Alternate assignment for ECCP2 when CCP2MX is cleared (Microcontroller mode only).
- 4:** Default assignment for P1B/P1C/P3B/P3C (ECCPMX is set).
- 5:** Alternate assignment for P1B/P1C/P3B/P3C (ECCPMX is clear).

PIC18F8723 FAMILY

[查询PIC18F8723供应商](#)

2.0 12-BIT ANALOG-TO-DIGITAL CONVERTER (A/D) MODULE

The Analog-to-Digital (A/D) Converter module has 12 inputs for the 64-pin devices (PIC18F6628/6723) and 16 for the 80-pin devices (PIC18F8628/8723). This module allows conversion of an analog input signal to a corresponding 12-bit digital number.

The module has five registers:

- A/D Result High Register (ADRESH)
- A/D Result Low Register (ADRESL)
- A/D Control Register 0 (ADCON0)
- A/D Control Register 1 (ADCON1)
- A/D Control Register 2 (ADCON2)

The ADCON0 register, shown in Register 2-1, controls the operation of the A/D module. The ADCON1 register, shown in Register 2-2, configures the functions of the port pins. The ADCON2 register, shown in Register 2-3, configures the A/D clock source, programmed acquisition time and justification.

REGISTER 2-1: ADCON0: A/D CONTROL REGISTER 0

U-0	U-0	R/W-0	R/W-0	R/W-0	R/W-0	R/W-0	R/W-0
—	—	CHS3	CHS2	CHS1	CHS0	GO/DONE	ADON
bit 7						bit 0	

Legend:

R = Readable bit

W = Writable bit

U = Unimplemented bit, read as '0'

-n = Value at POR

'1' = Bit is set

'0' = Bit is cleared

x = Bit is unknown

bit 7-6 **Unimplemented:** Read as '0'

bit 5-2 **CHS3:CHS0:** Analog Channel Select bits

0000 = Channel 0 (AN0)
 0001 = Channel 1 (AN1)
 0010 = Channel 2 (AN2)
 0011 = Channel 3 (AN3)
 0100 = Channel 4 (AN4)
 0101 = Channel 5 (AN5)
 0110 = Channel 6 (AN6)
 0111 = Channel 7 (AN7)
 1000 = Channel 8 (AN8)
 1001 = Channel 9 (AN9)
 1010 = Channel 10 (AN10)
 1011 = Channel 11 (AN11)
 1100 = Channel 12 (AN12)^(1,2)
 1101 = Channel 13 (AN13)^(1,2)
 1110 = Channel 14 (AN14)^(1,2)
 1111 = Channel 15 (AN15)^(1,2)

bit 1 **GO/DONE:** A/D Conversion Status bit

When ADON = 1:

1 = A/D conversion in progress
 0 = A/D Idle

bit 0 **ADON:** A/D On bit

1 = A/D Converter module is enabled
 0 = A/D Converter module is disabled

Note 1: These channels are not implemented on PIC18F6628/6723 devices.

2: Performing a conversion on unimplemented channels will return a floating input measurement.

PIC18F8723 FAMILY

查询PIC18F8723供应商

REGISTER 2-2. ADCON1: A/D CONTROL REGISTER 1

U-0	U-0	R/W-0	R/W-0	R/W-0	R/W-0	R/W-0	R/W-0
—	—	VCFG1	VCFG0	PCFG3	PCFG2	PCFG1	PCFG0
bit 7							bit 0

Legend:

R = Readable bit W = Writable bit U = Unimplemented bit, read as '0'
 -n = Value at POR '1' = Bit is set '0' = Bit is cleared x = Bit is unknown

bit 7-6

Unimplemented: Read as '0'

bit 5-4

VCFG1:VCFG0: Voltage Reference Configuration bits

	A/D VREF+	A/D VREF-
00	AVDD	AVSS
01	External VREF+	AVSS
10	AVDD	External VREF-
11	External VREF+	External VREF-

bit 3-0

PCFG3:PCFG0: A/D Port Configuration Control bits:

PCFG<3:0>	AN15 ⁽¹⁾	AN14 ⁽¹⁾	AN13 ⁽¹⁾	AN12 ⁽¹⁾	AN11	AN10	AN9	AN8	AN7	AN6	AN5	AN4	AN3	AN2	AN1	AN0
0000	A	A	A	A	A	A	A	A	A	A	A	A	A	A	A	A
0001	D	D	A	A	A	A	A	A	A	A	A	A	A	A	A	A
0010	D	D	D	A	A	A	A	A	A	A	A	A	A	A	A	A
0011	D	D	D	D	A	A	A	A	A	A	A	A	A	A	A	A
0100	D	D	D	D	D	A	A	A	A	A	A	A	A	A	A	A
0101	D	D	D	D	D	D	A	A	A	A	A	A	A	A	A	A
0110	D	D	D	D	D	D	D	A	A	A	A	A	A	A	A	A
0111	D	D	D	D	D	D	D	D	A	A	A	A	A	A	A	A
1000	D	D	D	D	D	D	D	D	D	A	A	A	A	A	A	A
1001	D	D	D	D	D	D	D	D	D	D	A	A	A	A	A	A
1010	D	D	D	D	D	D	D	D	D	D	D	A	A	A	A	A
1011	D	D	D	D	D	D	D	D	D	D	D	D	A	A	A	A
1100	D	D	D	D	D	D	D	D	D	D	D	D	D	A	A	A
1101	D	D	D	D	D	D	D	D	D	D	D	D	D	D	A	A
1110	D	D	D	D	D	D	D	D	D	D	D	D	D	D	D	A
1111	D	D	D	D	D	D	D	D	D	D	D	D	D	D	D	D

A = Analog input

D = Digital I/O

Note 1: AN15 through AN12 are available only on PIC18F8628/8723 devices.

PIC18F8723 FAMILY

[查询PIC18F8723供应商](#)

REGISTER 2-3: ADCON2: A/D CONTROL REGISTER 2

R/W-0	U-0	R/W-0	R/W-0	R/W-0	R/W-0	R/W-0	R/W-0
ADFM	—	ACQT2	ACQT1	ACQT0	ADCS2	ADCS1	ADCS0
bit 7							bit 0

Legend:

R = Readable bit

W = Writable bit

U = Unimplemented bit, read as '0'

-n = Value at POR

'1' = Bit is set

'0' = Bit is cleared

x = Bit is unknown

bit 7 **ADFM:** A/D Result Format Select bit

1 = Right justified

0 = Left justified

bit 6 **Unimplemented:** Read as '0'

bit 5-3 **ACQT2:ACQT0:** A/D Acquisition Time Select bits

111 = 20 TAD

110 = 16 TAD

101 = 12 TAD

100 = 8 TAD

011 = 6 TAD

010 = 4 TAD

001 = 2 TAD

000 = 0 TAD⁽¹⁾

bit 2-0 **ADCS2:ADCS0:** A/D Conversion Clock Select bits

111 = FRC (clock derived from A/D RC oscillator)⁽¹⁾

110 = FOSC/64

101 = FOSC/16

100 = FOSC/4

011 = FRC (clock derived from A/D RC oscillator)⁽¹⁾

010 = FOSC/32

001 = FOSC/8

000 = FOSC/2

Note 1: If the A/D FRC clock source is selected, a delay of one T_{CY} (instruction cycle) is added before the A/D clock starts. This allows the *SLEEP* instruction to be executed before starting a conversion.

PIC18F8723 FAMILY

[查询PIC18F8723供应商](#)

The analog reference voltage is software selectable to either the device's positive and negative supply voltage (VDD and VSS), or the voltage level on the RA3/AN3/VREF+ and RA2/AN2/VREF-/CVREF pins.

The A/D Converter has a unique feature of being able to operate while the device is in Sleep mode. To operate in Sleep, the A/D conversion clock must be derived from the A/D's internal RC oscillator.

The output of the sample and hold is the input into the converter, which generates the result via successive approximation.

A device Reset forces all registers to their Reset state. This forces the A/D module to be turned off and any conversion in progress is aborted.

Each port pin associated with the A/D Converter can be configured as an analog input or a digital I/O. The ADRESH and ADRESL registers contain the result of the A/D conversion. When the A/D conversion is complete, the result is loaded into the ADRESH:ADRESL register pair, the GO/DONE bit (ADCON0<1>) is cleared and the A/D Interrupt Flag bit, ADIF, is set. The block diagram of the A/D module is shown in Figure 2-1.

FIGURE 2-1: A/D BLOCK DIAGRAM

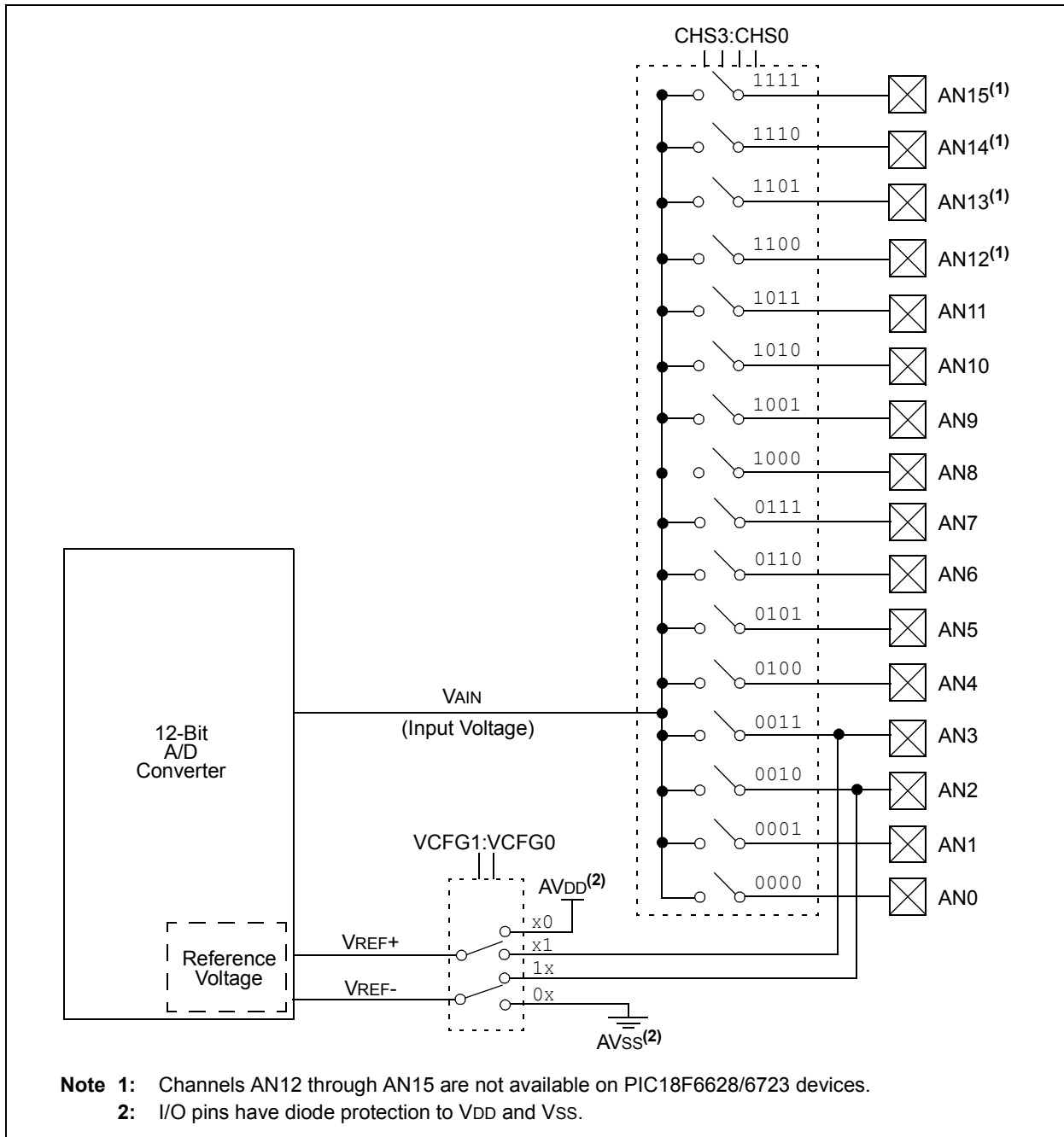

PIC18F8723 FAMILY

查询PIC18F8723供应商

The value in the ADRESH:ADRESL registers is unknown following Power-on and Brown-out Resets and is not affected by any other Reset.

After the A/D module has been configured as desired, the selected channel must be acquired before the conversion is started. The analog input channels must have their corresponding TRIS bits selected as an input. To determine acquisition time, see **Section 2.1 "A/D Acquisition Requirements"**. After this acquisition time has elapsed, the A/D conversion can be started. An acquisition time can be programmed to occur between setting the GO/DONE bit and the actual start of the conversion.

The following steps should be followed to perform an A/D conversion:

1. Configure the A/D module:
 - Configure analog pins, voltage reference and digital I/O (ADCON1)
 - Select A/D input channel (ADCON0)
 - Select A/D acquisition time (ADCON2)
 - Select A/D conversion clock (ADCON2)
 - Turn on A/D module (ADCON0)
2. Configure A/D interrupt (if desired):
 - Clear ADIF bit
 - Set ADIE bit
 - Set GIE bit
3. Wait the required acquisition time (if required).
4. Start conversion:
 - Set GO/DONE bit (ADCON0<1>)

5. Wait for A/D conversion to complete by either:
 - Polling for the GO/DONE bit to be cleared
 - OR
 - Waiting for the A/D interrupt
6. Read A/D Result registers (ADRESH:ADRESL); clear bit, ADIF, if required.
7. For next conversion, go to step 1 or step 2, as required. The A/D conversion time per bit is defined as T_{AD}. A minimum wait of 2 T_{AD} is required before the next acquisition starts.

FIGURE 2-2: A/D TRANSFER FUNCTION

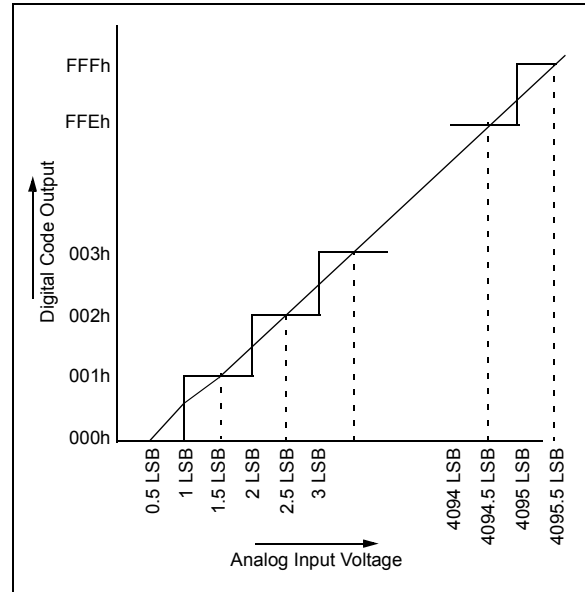
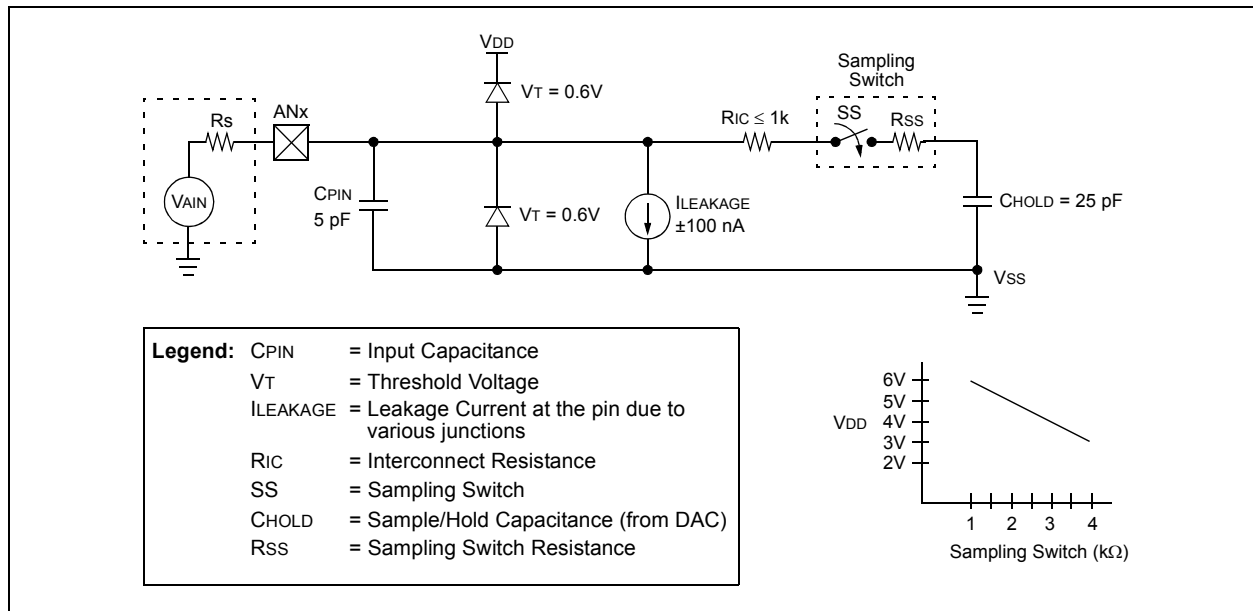

FIGURE 2-3: ANALOG INPUT MODEL



PIC18F8723 FAMILY

[查询PIC18F8723供应商](#)

2.1 A/D Acquisition Requirements

For the A/D Converter to meet its specified accuracy, the charge holding capacitor (CHOLD) must be allowed to fully charge to the input channel voltage level. The analog input model is shown in Figure 2-3. The source impedance (R_s) and the internal sampling switch (R_{SS}) impedance directly affect the time required to charge the capacitor, CHOLD. The sampling switch (R_{SS}) impedance varies over the device voltage (V_{DD}). The source impedance affects the offset voltage at the analog input (due to pin leakage current). **The maximum recommended impedance for analog sources is 2.5 k Ω .** After the analog input channel is selected (changed), the channel must be sampled for at least the minimum acquisition time before starting a conversion.

Note: When the conversion is started, the holding capacitor is disconnected from the input pin.

To calculate the minimum acquisition time, Equation 2-1 may be used. This equation assumes that 1/2 LSb error is used (4096 steps for the 12-bit A/D). The 1/2 LSb error is the maximum error allowed for the A/D to meet its specified resolution.

Example 2-3 shows the calculation of the minimum required acquisition time, TACQ. This calculation is based on the following application system assumptions:

CHOLD	=	25 pF
R_s	=	2.5 k Ω
Conversion Error	\leq	1/2 LSb
V_{DD}	=	3V \rightarrow $R_{SS} = 4$ k Ω
Temperature	=	85°C (system max.)

EQUATION 2-1: ACQUISITION TIME

$$\begin{aligned} TACQ &= \text{Amplifier Settling Time} + \text{Holding Capacitor Charging Time} + \text{Temperature Coefficient} \\ &= TAMP + TC + TCOFF \end{aligned}$$

EQUATION 2-2: A/D MINIMUM CHARGING TIME

$$\begin{aligned} V_{HOLD} &= (V_{REF} - (V_{REF}/4096)) \cdot (1 - e^{-(TC/CHOLD)(R_{IC} + R_{SS} + R_s)}) \\ \text{or} \\ TC &= -(CHOLD)(R_{IC} + R_{SS} + R_s) \ln(1/4096) \end{aligned}$$

EQUATION 2-3: CALCULATING THE MINIMUM REQUIRED ACQUISITION TIME

$$\begin{aligned} TACQ &= TAMP + TC + TCOFF \\ TAMP &= 0.2 \mu\text{s} \\ TCOFF &= (\text{Temp} - 25^\circ\text{C})(0.02 \mu\text{s}/^\circ\text{C}) \\ &\quad (85^\circ\text{C} - 25^\circ\text{C})(0.02 \mu\text{s}/^\circ\text{C}) \\ &\quad 1.2 \mu\text{s} \end{aligned}$$

Temperature coefficient is only required for temperatures $> 25^\circ\text{C}$. Below 25°C , TCOFF = 0 μs .

$$\begin{aligned} TC &= -(CHOLD)(R_{IC} + R_{SS} + R_s) \ln(1/4096) \mu\text{s} \\ &\quad -(25 \text{ pF})(1 \text{ k}\Omega + 4 \text{ k}\Omega + 2.5 \text{ k}\Omega) \ln(0.0002441) \mu\text{s} \\ &\quad 1.56 \mu\text{s} \\ TACQ &= 0.2 \mu\text{s} + 1.56 \mu\text{s} + 1.2 \mu\text{s} \\ &\quad 2.96 \mu\text{s} \end{aligned}$$

2.2 Selecting and Configuring Acquisition Time

The ADCON2 register allows the user to select an acquisition time that occurs each time the GO/DONE bit is set. It also gives users the option to use an automatically determined acquisition time.

Acquisition time may be set with the ACQT2:ACQT0 bits (ADCON2<5:3>), which provide a range of 2 to 20 TAD. When the GO/DONE bit is set, the A/D module continues to sample the input for the selected acquisition time, then automatically begins a conversion. Since the acquisition time is programmed, there may be no need to wait for an acquisition time between selecting a channel and setting the GO/DONE bit.

Manual acquisition is selected when ACQT2:ACQT0 = 000. When the GO/DONE bit is set, sampling is stopped and a conversion begins. The user is responsible for ensuring the required acquisition time has passed between selecting the desired input channel and setting the GO/DONE bit. This option is also the default Reset state of the ACQT2:ACQT0 bits and is compatible with devices that do not offer programmable acquisition times.

In either case, when the conversion is completed, the GO/DONE bit is cleared, the ADIF flag is set and the A/D begins sampling the currently selected channel again. If an acquisition time is programmed, there is nothing to indicate if the acquisition time has ended or if the conversion has begun.

2.3 Selecting the A/D Conversion Clock

The A/D conversion time per bit is defined as TAD. The A/D conversion requires 13 TAD per 12-bit conversion. The source of the A/D conversion clock is software selectable. There are seven possible options for TAD:

- 2 TOSC
- 4 TOSC
- 8 TOSC
- 16 TOSC
- 32 TOSC
- 64 TOSC
- Internal RC Oscillator

For correct A/D conversions, the A/D conversion clock (TAD) must be as short as possible, but greater than the minimum TAD (see parameter 130 for more information).

Table 2-1 shows the resultant TAD times derived from the device operating frequencies and the A/D clock source selected.

TABLE 2-1: TAD vs. DEVICE OPERATING FREQUENCIES

A/D Clock Source (TAD)		Assumes TAD Min. = 0.8 μ s
Operation	ADCS2:ADCS0	Maximum FOSC
2 TOSC	000	2.50 MHz
4 TOSC	100	5.00 MHz
8 TOSC	001	10.00 MHz
16 TOSC	101	20.00 MHz
32 TOSC	010	40.00 MHz
64 TOSC	110	40.00 MHz
RC ⁽¹⁾	x11	1.00 MHz ⁽²⁾

Note 1: The RC source has a typical TAD time of 2.5 μ s.

2: For device frequencies above 1 MHz, the device must be in Sleep for the entire conversion or a FOSC divider should be used instead; otherwise, the A/D accuracy specification may not be met.

PIC18F8723 FAMILY

[查询PIC18F8723供应商](#)

2.4 Operation in Power-Managed Modes

The selection of the automatic acquisition time and A/D conversion clock is determined in part by the clock source and frequency while in a power-managed mode.

If the A/D is expected to operate while the device is in a power-managed mode, the AD_{CS}2:AD_{CS}0 bits in AD_{CON}2 should be updated in accordance with the clock source to be used. The AC_{QT}2:AC_{QT}0 bits do not need to be adjusted as the AD_{CS}2:AD_{CS}0 bits adjust the T_{AD} time for the new clock speed. After entering the mode, an A/D acquisition or conversion may be started. Once started, the device should continue to be clocked by the same clock source until the conversion has been completed.

If desired, the device may be placed into the corresponding Idle mode during the conversion. If the device clock frequency is less than 1 MHz, the A/D RC clock source should be selected.

Operation in Sleep mode requires the A/D FRC clock to be selected. If the AC_{QT}2:AC_{QT}0 bits are set to '000' and a conversion is started, the conversion will be delayed one instruction cycle to allow execution of the SLEEP instruction and entry to Sleep mode. The IDLEN bit (OSCCON<7>) must have already been cleared prior to starting the conversion.

2.5 Configuring Analog Port Pins

The AD_{CON}1, TRISA, TRISF and TRISH registers all configure the A/D port pins. The port pins needed as analog inputs must have their corresponding TRIS bits set (input). If the TRIS bit is cleared (output), the digital output level (V_{OH} or V_{OL}) will be converted.

The A/D operation is independent of the state of the CHS3:CHS0 bits and the TRIS bits.

Note 1: When reading the PORT register, all pins configured as analog input channels will read as cleared (a low level). Analog conversion on pins configured as digital pins can be performed. The voltage on the pin will be accurately converted.

2: Analog levels on any pin defined as a digital input may cause the digital input buffer to consume current out of the device's specification limits.

2.6 A/D Conversions

Figure 2-4 shows the operation of the A/D Converter after the $\overline{\text{GO/DONE}}$ bit has been set and the ACQT2:ACQT0 bits are cleared. A conversion is started after the following instruction to allow entry into Sleep mode before the conversion begins.

Figure 2-5 shows the operation of the A/D Converter after the $\overline{\text{GO/DONE}}$ bit has been set, the ACQT2:ACQT0 bits are set to '010' and a 4 TAD acquisition time has been selected before the conversion starts.

Clearing the $\overline{\text{GO/DONE}}$ bit during a conversion will abort the current conversion. The A/D Result register pair will NOT be updated with the partially completed A/D conversion sample. This means the ADRESH:ADRESL registers will continue to contain the value of the last completed conversion (or the last value written to the ADRESH:ADRESL registers).

After the A/D conversion is completed or aborted, a 2 T_{CY} wait is required before the next acquisition can be started. After this wait, acquisition on the selected channel is automatically started.

Note: The $\overline{\text{GO/DONE}}$ bit should **NOT** be set in the same instruction that turns on the A/D. Code should wait at least 2 μs after enabling the A/D before beginning an acquisition and conversion cycle.

2.7 Discharge

The discharge phase is used to initialize the value of the holding capacitor. The array is discharged before every sample. This feature helps to optimize the unity gain amplifier, as the circuit always needs to charge the capacitor array, rather than charge/discharge based on previous measure values.

FIGURE 2-4: A/D CONVERSION TAD CYCLES (ACQT<2:0> = 000, TACQ = 0)

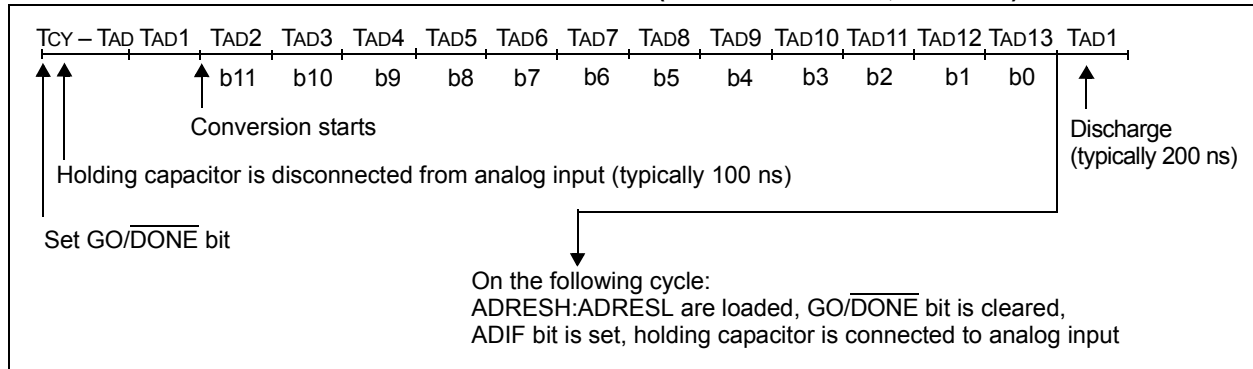
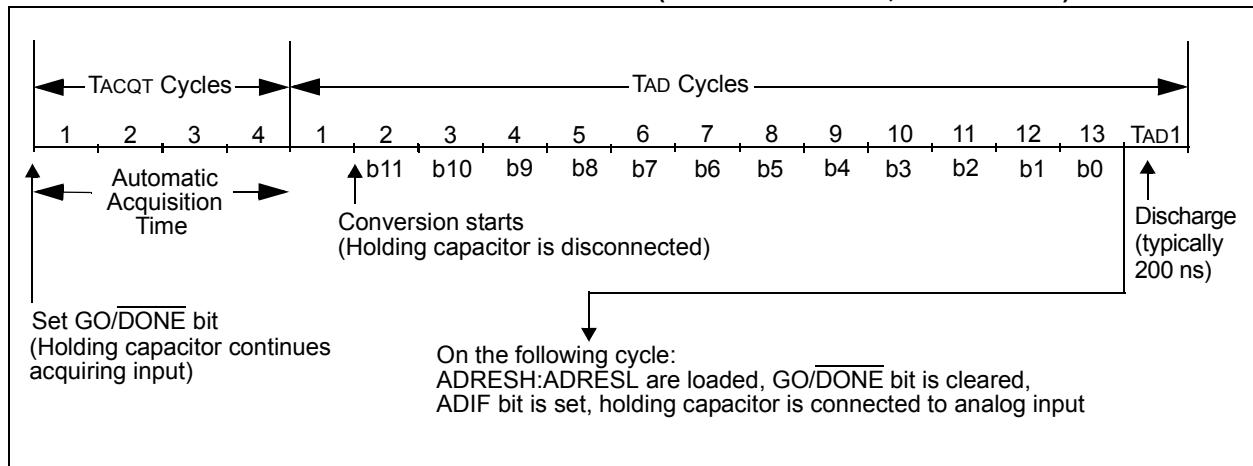

FIGURE 2-5: A/D CONVERSION TAD CYCLES (ACQT<2:0> = 010, TACQ = 4 TAD)



PIC18F8723 FAMILY

[查询PIC18F8723供应商](#)

2.8 Use of the ECCP2 Trigger

An A/D conversion can be started by the Special Event Trigger of the ECCP2 module. This requires that the CCP2M3:CCP2M0 bits (CCP2CON<3:0>) be programmed as '1011' and that the A/D module is enabled (ADON bit is set). When the trigger occurs, the GO/DONE bit will be set, starting the A/D acquisition and conversion, and the Timer1 (or Timer3) counter will be reset to zero. Timer1 (or Timer3) is reset to automatically repeat the A/D acquisition period with minimal software overhead (moving ADRESH:ADRESL to the

desired location). The appropriate analog input channel must be selected and the minimum acquisition period is either timed by the user, or an appropriate TACQ time selected before the Special Event Trigger sets the GO/DONE bit (starts a conversion).

If the A/D module is not enabled (ADON is cleared), the Special Event Trigger will be ignored by the A/D module but will still reset the Timer1 (or Timer3) counter.

TABLE 2-2: REGISTERS ASSOCIATED WITH A/D OPERATION

Name	Bit 7	Bit 6	Bit 5	Bit 4	Bit 3	Bit 2	Bit 1	Bit 0	Reset Values
INTCON	GIE/GIEH	PEIE/GIEL	TMR0IE	INT0IE	RBIE	TMR0IF	INT0IF	RBIF	(3)
PIR1	PSPIF	ADIF	RC1IF	TX1IF	SSP1IF	CCP1IF	TMR2IF	TMR1IF	(3)
PIE1	PSPIE	ADIE	RC1IE	TX1IE	SSP1IE	CCP1IE	TMR2IE	TMR1IE	(3)
IPR1	PSPIP	ADIP	RC1IP	TX1IP	SSP1IP	CCP1IP	TMR2IP	TMR1IP	(3)
PIR2	OSCFIF	CMIF	—	EEIF	BCL1IF	HLVDIF	TMR3IF	CCP2IF	(3)
PIE2	OSCFIE	CMIE	—	EEIE	BCL1IE	HLVDIE	TMR3IE	CCP2IE	(3)
IPR2	OSCFIP	CMIP	—	EEIP	BCL1IP	HLVDIP	TMR3IP	CCP2IP	(3)
ADRESH	A/D Result Register High Byte								(3)
ADRESL	A/D Result Register Low Byte								(3)
ADCON0	—	—	CHS3	CHS2	CHS1	CHS0	GO/DONE	ADON	(3)
ADCON1	—	—	VCFG1	VCFG0	PCFG3	PCFG2	PCFG1	PCFG0	(3)
ADCON2	ADFM	—	ACQT2	ACQT1	ACQT0	ADCS2	ADCS1	ADCS0	(3)
TRISA	TRISA7 ⁽¹⁾	TRISA6 ⁽¹⁾	TRISA5	TRISA4	TRISA3	TRISA2	TRISA1	TRISA0	(3)
TRISF	TRISF7	TRISF6	TRISF5	TRISF4	TRISF3	TRISF2	TRISF1	TRISF0	(3)
TRISH ⁽²⁾	TRISH7	TRISH6	TRISH5	TRISH4	TRISH3	TRISH2	TRISH1	TRISH0	(3)

Legend: — = unimplemented, read as '0'. Shaded cells are not used for A/D conversion.

Note 1: PORTA<7:6> and their direction bits are individually configured as port pins based on various primary oscillator modes. When disabled, these bits read as '0'.

2: These registers are not implemented on PIC18F6628/6723 devices.

3: For these Reset values, see the "PIC18F8722 Family Data Sheet" (DS39646).

PIC18F8723 FAMILY

[查询PIC18F8723供应商](#)

3.0 SPECIAL FEATURES OF THE CPU

Note: For additional details on the Configuration bits, refer to **Section 25.1 “Configuration Bits”** in the *“PIC18F8722 Family Data Sheet”* (DS39646). Device ID information presented in this section is for the PIC18F8723 family only.

PIC18F8723 family devices include several features intended to maximize reliability and minimize cost through elimination of external components. These include:

- Device ID Registers

3.1 Device ID Registers

The Device ID registers are “read-only” registers. They identify the device type and revision to device programmers and can be read by firmware using table reads.

TABLE 3-1: DEVICE IDs

File Name	Bit 7	Bit 6	Bit 5	Bit 4	Bit 3	Bit 2	Bit 1	Bit 0	Default/ Unprogrammed Value	
3FFFFEh	DEVID1	DEV2	DEV1	DEV0	REV4	REV3	REV2	REV1	REV0	xxxx xxxx ⁽¹⁾
3FFFFFh	DEVID2	DEV10	DEV9	DEV8	DEV7	DEV6	DEV5	DEV4	DEV3	xxxx xxxx ⁽¹⁾

Legend: x = unknown

Note 1: See Register 3-1 and Register 3-2 for DEVID values. DEVID registers are read-only and cannot be programmed by the user.

PIC18F8723 FAMILY

[查询PIC18F8723供应商](#)

REGISTER 3-1: DEVID1: DEVICE ID REGISTER 1 FOR PIC18F8723 FAMILY DEVICES

R	R	R	R	R	R	R	R
DEV2	DEV1	DEV0	REV4	REV3	REV2	REV1	REV0
bit 7							bit 0

Legend:

R = Read-only bit P = Programmable bit U = Unimplemented bit, read as '0'
 -n = Value when device is unprogrammed u = Unchanged from programmed state

bit 7-5 **DEV2:DEV0:** Device ID bits
 See Register 3-2 for a complete listing.

bit 4-0 **REV4:REV0:** Revision ID bits
 These bits are used to indicate the device revision.

REGISTER 3-2: DEVID2: DEVICE ID REGISTER 2 FOR PIC18F8723 FAMILY DEVICES

R	R	R	R	R	R	R	R
DEV10	DEV9	DEV8	DEV7	DEV6	DEV5	DEV4	DEV3
bit 7							bit 0

Legend:

R = Read-only bit P = Programmable bit U = Unimplemented bit, read as '0'
 -n = Value when device is unprogrammed u = Unchanged from programmed state

bit 7-0 **DEV10:DEV3:** Device ID bits

DEV10:DEV3 (DEVID2<7:0>)	DEV2:DEV0 (DEVID1<7:5>)	Device
0100 1001	110	PIC18F6628
0100 1010	000	PIC18F6723
0100 1001	111	PIC18F8628
0100 1010	001	PIC18F8723

PIC18F8723 FAMILY

[查询PIC18F8723供应商](#)

4.0 ELECTRICAL CHARACTERISTICS

Note: Other than some basic data, this section documents only the PIC18F8723 family's specifications that differ from those of the PIC18F8722 family devices. For detailed information on the electrical specifications shared by the PIC18F8723 family and PIC18F8722 family devices, see the "PIC18F8722 Family Data Sheet" (DS39646).

Absolute Maximum Ratings^(†)

Ambient temperature under bias	-40°C to +125°C
Storage temperature	-65°C to +150°C
Voltage on any pin with respect to V _{SS} (except V _{DD} and $\overline{\text{MCLR}}$)	-0.3V to (V _{DD} + 0.3V)
Voltage on V _{DD} with respect to V _{SS}	-0.3V to +7.5V
Voltage on $\overline{\text{MCLR}}$ with respect to V _{SS} (Note 2)	0V to +13.25V
Total power dissipation (Note 1)	1.0W
Maximum current out of V _{SS} pin	300 mA
Maximum current into V _{DD} pin	250 mA
Input clamp current, I _{IK} (V _I < 0 or V _I > V _{DD})	±20 mA
Output clamp current, I _{OK} (V _O < 0 or V _O > V _{DD})	±20 mA
Maximum output current sunk by any I/O pin	25 mA
Maximum output current sourced by any I/O pin	25 mA
Maximum current sunk by all ports	200 mA
Maximum current sourced by all ports	200 mA

Note 1: Power dissipation is calculated as follows:

$$P_{dis} = V_{DD} \times \{I_{DD} - \sum I_{OH}\} + \sum \{(V_{DD} - V_{OH}) \times I_{OH}\} + \sum (V_{OL} \times I_{OL})$$

2: Voltage spikes below V_{SS} at the RG5/ $\overline{\text{MCLR}}$ /V_{PP} pin, inducing currents greater than 80 mA, may cause latch-up. Thus, a series resistor of 50-100Ω should be used when applying a "low" level to the RG5/ $\overline{\text{MCLR}}$ /V_{PP} pin, rather than pulling this pin directly to V_{SS}.

† **NOTICE:** Stresses above those listed under "Absolute Maximum Ratings" may cause permanent damage to the device. This is a stress rating only and functional operation of the device at those or any other conditions above those indicated in the operation listings of this specification is not implied. Exposure to maximum rating conditions for extended periods may affect device reliability.

PIC18F8723 FAMILY

[查询PIC18F8723供应商](#)

FIGURE 4-1: PIC18F8723 FAMILY VOLTAGE-FREQUENCY GRAPH (INDUSTRIAL)

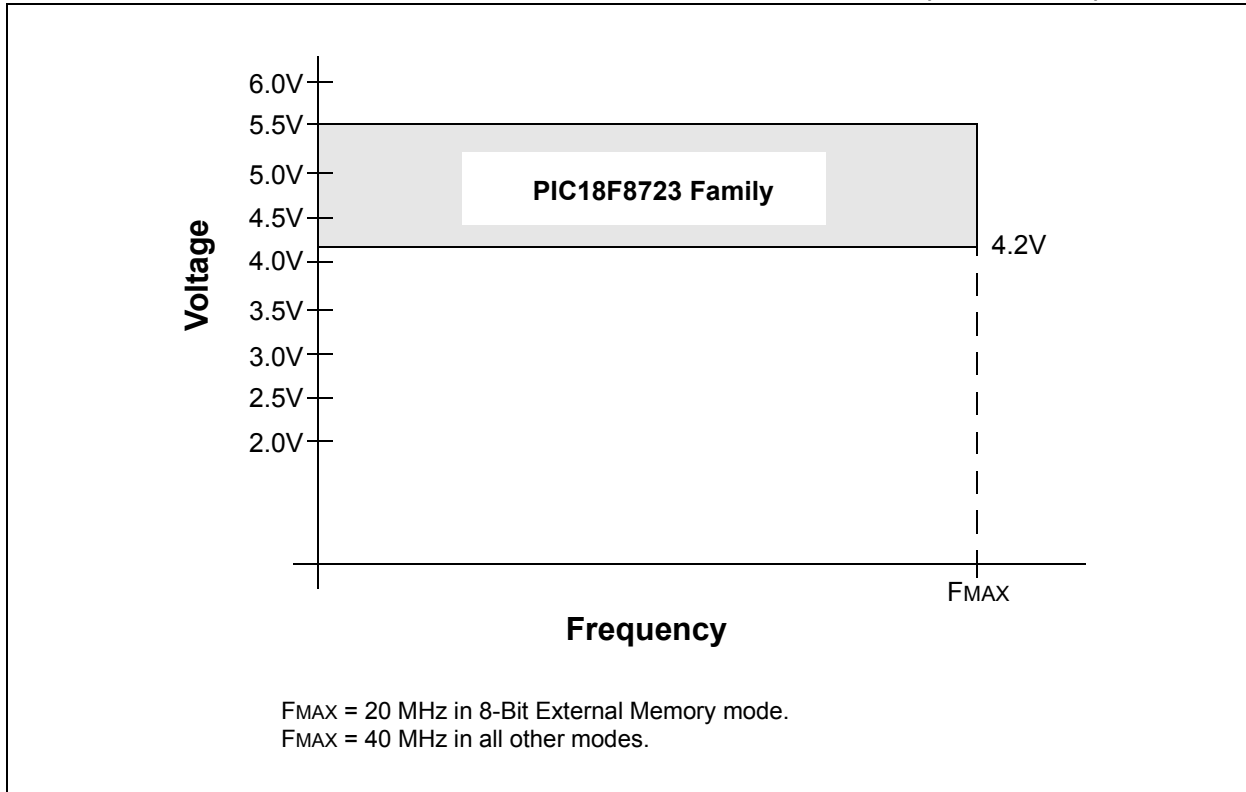
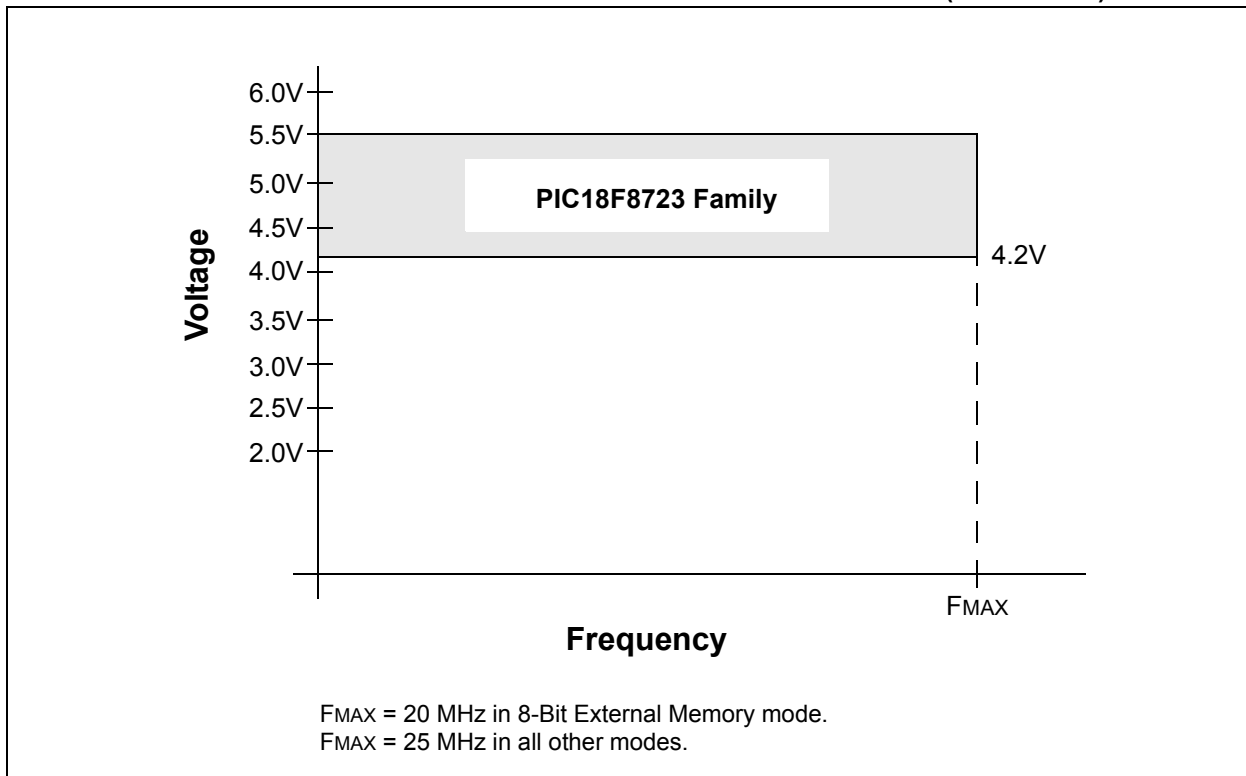

FIGURE 4-2: PIC18F8723 FAMILY VOLTAGE-FREQUENCY GRAPH (EXTENDED)



PIC18F8723 FAMILY

[查询PIC18F8723供应商](#)

FIGURE 4-3: PIC18LF8723 FAMILY VOLTAGE-FREQUENCY GRAPH (INDUSTRIAL)

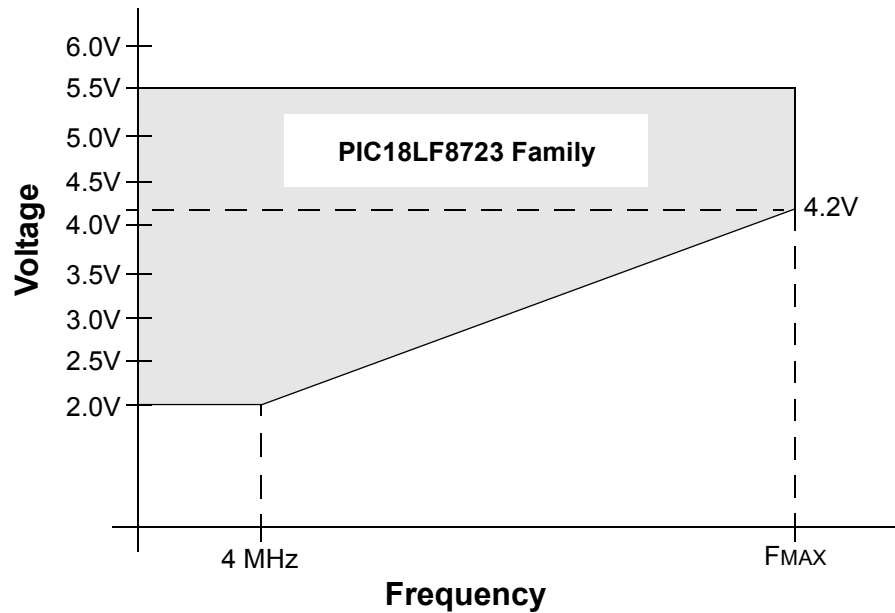

In 8-Bit External Memory mode:

$F_{MAX} = (9.55 \text{ MHz/V}) (V_{DDAPP_{MIN}} - 2.0\text{V}) + 4 \text{ MHz}$, if $V_{DDAPP_{MIN}} \leq 4.2\text{V}$;
 $F_{MAX} = 25 \text{ MHz}$, if $V_{DDAPP_{MIN}} > 4.2\text{V}$.

In all other modes:

$F_{MAX} = (16.36 \text{ MHz/V}) (V_{DDAPP_{MIN}} - 2.0\text{V}) + 4 \text{ MHz}$;
 $F_{MAX} = 40 \text{ MHz}$, if $V_{DDAPP_{MIN}} > 4.2\text{V}$.

Note: $V_{DDAPP_{MIN}}$ is the minimum voltage of the PIC[®] device in the application.

PIC18F8723 FAMILY

[查询PIC18F8723供应商](#)

TABLE 4-1: A/D CONVERTER CHARACTERISTICS: PIC18F8723 FAMILY (INDUSTRIAL)

Param No.	Sym	Characteristic	Min	Typ	Max	Units	Conditions	
A01	NR	Resolution	—	—	12	bit		$\Delta V_{REF} \geq 3.0V$
A03	EIL	Integral Linearity Error	—	$<\pm 1$	± 2.0	LSB	$V_{DD} = 3.0V$	$\Delta V_{REF} \geq 3.0V$
			—	—	± 2.0	LSB	$V_{DD} = 5.0V$	
A04	EDL	Differential Linearity Error	—	$<\pm 1$	+1.5/-1.0	LSB	$V_{DD} = 3.0V$	$\Delta V_{REF} \geq 3.0V$
			—	—	+1.5/-1.0	LSB	$V_{DD} = 5.0V$	
A06	EOFF	Offset Error	—	$<\pm 1$	± 5	LSB	$V_{DD} = 3.0V$	$\Delta V_{REF} \geq 3.0V$
			—	—	± 3	LSB	$V_{DD} = 5.0V$	
A07	EGN	Gain Error	—	$<\pm 1$	± 1.25	LSB	$V_{DD} = 3.0V$	$\Delta V_{REF} \geq 3.0V$
			—	—	± 2.00	LSB	$V_{DD} = 5.0V$	
A10	—	Monotonicity	Guaranteed ⁽¹⁾			—	$V_{SS} \leq V_{AIN} \leq V_{REF}$	
A20	ΔV_{REF}	Reference Voltage Range ($V_{REFH} - V_{REFL}$)	3	—	$V_{DD} - V_{SS}$	V	For 12-bit resolution	
A21	V_{REFH}	Reference Voltage High	$V_{SS} + 3.0V$	—	$V_{DD} + 0.3V$	V	For 12-bit resolution	
A22	V_{REFL}	Reference Voltage Low	$V_{SS} - 0.3V$	—	$V_{DD} - 3.0V$	V	For 12-bit resolution	
A25	V_{AIN}	Analog Input Voltage	V_{REFL}	—	V_{REFH}	V		
A30	Z_{AIN}	Recommended Impedance of Analog Voltage Source	—	—	2.5	k Ω		
A50	I _{REF}	V_{REF} Input Current ⁽²⁾	—	—	5	μA	During V_{AIN} acquisition. During A/D conversion cycle.	
			—	—	150	μA		

- Note 1:** The A/D conversion result never decreases with an increase in the input voltage and has no missing codes.
- Note 2:** V_{REFH} current is from the RA3/AN3/ V_{REF+} pin or V_{DD} , whichever is selected as the V_{REFH} source. V_{REFL} current is from the RA2/AN2/ V_{REF-}/CV_{REF} pin or V_{SS} , whichever is selected as the V_{REFL} source.

PIC18F8723 FAMILY

[查询PIC18F8723供应商](#)

FIGURE 4-4: A/D CONVERSION TIMING

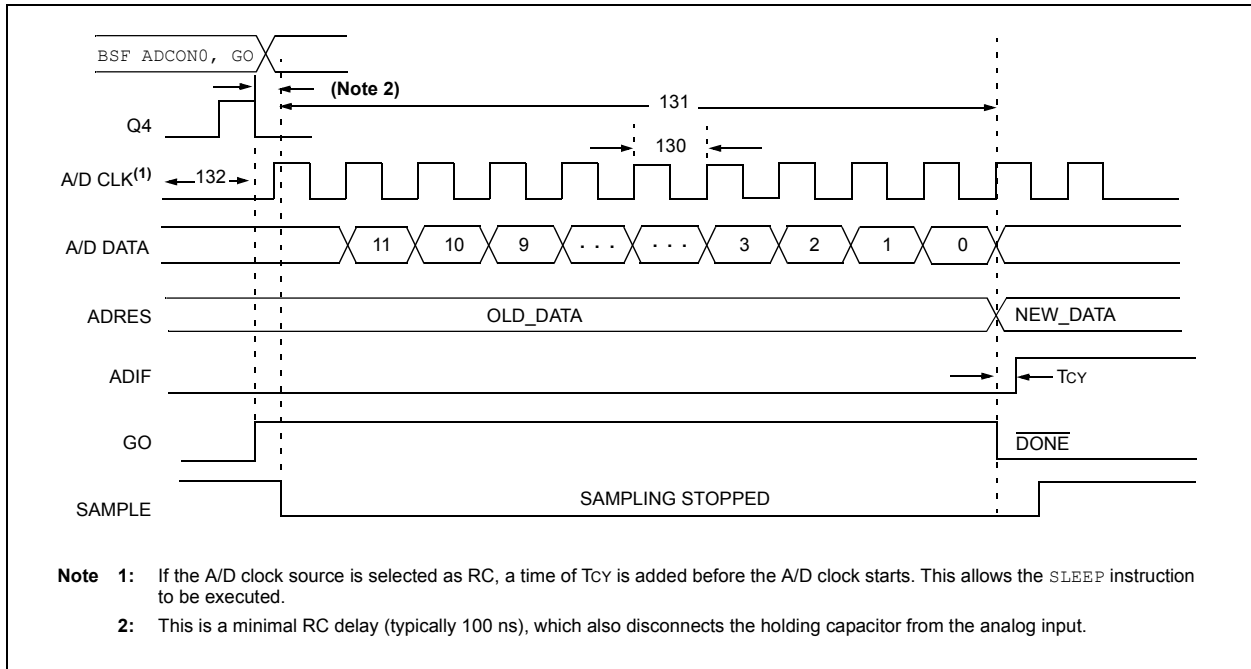

TABLE 4-2: A/D CONVERSION REQUIREMENTS

Param No.	Symbol	Characteristic	Min	Max	Units	Conditions	
130	TAD	A/D Clock Period	PIC18FXXXX	0.8	12.5 ⁽¹⁾	μs	TOSC based, VREF ≥ 3.0V
			PIC18LFXXXX	1.4	25.0 ⁽¹⁾	μs	VDD = 3.0V; TOSC based, VREF full range
		PIC18FXXXX	—	1	μs	A/D RC mode	
		PIC18LFXXXX	—	3	μs	VDD = 3.0V; A/D RC mode	
131	T _{cnv}	Conversion Time (not including acquisition time) ⁽²⁾	13	14	TAD		
132	T _{acq}	Acquisition Time ⁽³⁾	1.4	—	μs		
135	T _{swc}	Switching Time from Convert → Sample	—	(Note 4)			
137	T _{dis}	Discharge Time	0.2	—	μs		

- Note 1:** The time of the A/D clock period is dependent on the device frequency and the TAD clock divider.
- Note 2:** ADRES registers may be read on the following T_{cy} cycle.
- Note 3:** The time for the holding capacitor to acquire the “New” input voltage when the voltage changes full scale after the conversion (VDD to VSS or VSS to VDD). The source impedance (R_s) on the input channels is 50Ω.
- Note 4:** On the following cycle of the device clock.

PIC18F8723 FAMILY

[查询PIC18F8723供应商](#)

NOTES:

[查询PIC18F8723供应商](#)

5.0 PACKAGING INFORMATION

For packaging information, see the “*PIC18F8722 Family Data Sheet*” (DS39646).

PIC18F8723 FAMILY

[查询PIC18F8723供应商](#)

NOTES:

PIC18F8723 FAMILY

[查询PIC18F8723供应商](#)

APPENDIX A: REVISION HISTORY

Revision A (August 2007)

Original data sheet for the PIC18F8723 family of devices.

Revision B (October 2009)

Updated to remove Preliminary status.

APPENDIX B: DEVICE DIFFERENCES

The differences between the devices listed in this data sheet are shown in Table B-1.

TABLE B-1: PIC18F8723 FAMILY DEVICE DIFFERENCES

Features	PIC18F6628	PIC18F6723	PIC18F8628	PIC18F8723
Program Memory (Bytes)	96K	128K	96K	128K
Program Memory (Instructions)	49152	65536	49152	65536
Interrupt Sources	28	28	29	29
I/O Ports	Ports A, B, C, D, E, F, G	Ports A, B, C, D, E, F, G	Ports A, B, C, D, E, F, G, H, J	Ports A, B, C, D, E, F, G, H, J
Capture/Compare/PWM Modules	2	2	2	2
Enhanced Capture/Compare/PWM Modules	3	3	3	3
Parallel Communications (PSP)	Yes	Yes	Yes	Yes
External Memory Bus	No	No	Yes	Yes
12-Bit Analog-to-Digital Module	12 Input Channels	12 Input Channels	16 Input Channels	16 Input Channels
Packages	64-Pin TQFP	64-Pin TQFP	80-Pin TQFP	80-Pin TQFP

PIC18F8723 FAMILY

[查询PIC18F8723供应商](#)

APPENDIX C: CONVERSION CONSIDERATIONS

This appendix discusses the considerations for converting from previous versions of a device to the ones listed in this data sheet. Typically, these changes are due to the differences in the process technology used. An example of this type of conversion is from a PIC16C74A to a PIC16C74B.

Not Applicable

APPENDIX D: MIGRATION FROM BASELINE TO ENHANCED DEVICES

This section discusses how to migrate from a Baseline device (i.e., PIC16C5X) to an Enhanced MCU device (i.e., PIC18FXXX).

The following are the list of modifications over the PIC16C5X microcontroller family:

Not Currently Available

[查询PIC18F8723供应商](#)

APPENDIX E: MIGRATION FROM MID-RANGE TO ENHANCED DEVICES

A detailed discussion of the differences between the mid-range MCU devices (i.e., PIC16CXXX) and the enhanced devices (i.e., PIC18FXXX) is provided in AN716, "*Migrating Designs from PIC16C74A/74B to PIC18C442*". The changes discussed, while device specific, are generally applicable to all mid-range to enhanced device migrations.

This Application Note is available on our web site, www.microchip.com, as Literature Number DS00716.

APPENDIX F: MIGRATION FROM HIGH-END TO ENHANCED DEVICES

A detailed discussion of the migration pathway and differences between the high-end MCU devices (i.e., PIC17CXXX) and the enhanced devices (i.e., PIC18FXXX) is provided in AN726, "*PIC17CXXX to PIC18CXXX Migration*".

This Application Note is available on our web site, www.microchip.com, as Literature Number DS00726.

PIC18F8723 FAMILY

[查询PIC18F8723供应商](#)

NOTES:

PIC18F8723 FAMILY

[查询PIC18F8723供应商](#)

INDEX

A

A/D	31
A/D Converter Interrupt, Configuring	35
Acquisition Requirements	36
ADCON0 Register	31
ADCON1 Register	31
ADCON2 Register	31
ADRESH Register	31, 34
ADRESL Register	31
Analog Port Pins, Configuring	38
Associated Registers	40
Configuring the Module	35
Conversion Clock (TAD)	37
Conversion Status (GO/DONE Bit)	34
Conversions	39
Converter Characteristics	46
Discharge	39
Operation in Power-Managed Modes	38
Selecting and Configuring Acquisition Time	37
Special Event Trigger (ECCP2)	40
Transfer Function	35
Use of the ECCP2 Trigger	40
Absolute Maximum Ratings	43
ADCON0 Register	31
GO/DONE Bit	34
ADCON1 Register	31
ADCON2 Register	31
ADRESH Register	31
ADRESL Register	31, 34
Analog-to-Digital Converter. See A/D.	

B

Block Diagrams	
A/D	34
Analog Input Model	35
PIC18F6628/6723	11
PIC18F8628/8723	12

C

Compare (ECCP2 Module)	
Special Event Trigger	40
Conversion Considerations	52
Customer Change Notification Service	57
Customer Notification Service	57
Customer Notification System	7
Customer Support	57

D

Device Differences	51
Device ID Registers	41
Device Overview	
Features (table)	10
Special Features	9

E

Electrical Characteristics	43
Equations	
A/D Acquisition Time	36
A/D Minimum Charging Time	36
Calculating the Minimum Required Acquisition Time	36
Errata	7
External Memory Interface	3

F

Features Summary Table	3
------------------------	---

I

Internet Address	57
Interrupt Sources	
A/D Conversion Complete	35

M

Microchip Internet Web Site	57
Migration From Baseline to Enhanced Devices	52
Migration From High-End to Enhanced Devices	53
Migration From Mid-Range to Enhanced Devices	53
More Information	7
Customer Notification System	7
Errata	7

O

Overview	
External Memory Interface	3
Features Summary Table	3
Peripheral Highlights	3
Power-Managed Modes	3
Special Microcontroller Features	3

P

Packaging Information	49
Peripheral Highlights	3
Pin Diagrams	
64-Pin TQFP	4
80-Pin TQFP	5
Pin Functions	
AVDD (64-pin)	20
AVDD (80-pin)	30
AVss (64-pin)	20
AVss (80-pin)	30
OSC1/CLKI/RA7	13, 21
OSC2/CLKO/RA6	13, 21
RA0/AN0	14, 22
RA1/AN1	14, 22
RA2/AN2/VREF-	14, 22
RA3/AN3/VREF+	14, 22
RA4/T0CKI	14, 22
RA5/AN4/HLVDIN	14, 22
RB0/INT0/FLT0	15, 23
RB1/INT1	15, 23
RB2/INT2	15, 23
RB3/INT3	15
RB3/INT3/ECCP2/P2A	23
RB4/KBI0	15, 23
RB5/KBI1/PGM	15, 23
RB6/KBI2/PGC	15, 23
RB7/KBI3/PGD	15, 23
RC0/T1OSO/T13CKI	16, 24
RC1/T1OSI/ECCP2/P2A	16, 24
RC2/ECCP1/P1A	16, 24
RC3/SCK1/SCL1	16, 24
RC4/SDI1/SDA1	16, 24
RC5/SDO1	16, 24
RC6/TX1/CK1	16, 24
RC7/RX1/DT1	16, 24
RD0/AD0/PSP0	25
RD0/PSP0	17

PIC18F8723 FAMILY

[查询PIC18F8723供应商](#)

RD1/AD1/PSP1	25
RD1/PSP1	17
RD2/AD2/PSP2	25
RD2/PSP2	17
RD3/AD3/PSP3	25
RD3/PSP3	17
RD4/AD4/PSP4/SDO2	25
RD4/PSP4/SDO2	17
RD5/AD5/PSP5/SDI2/SDA2	25
RD5/PSP5/SDI2/SDA2	17
RD6/AD6/PSP6/SCK2/SCL2	25
RD6/PSP6/SCK2/SCL2	17
RD7/AD7/PSP7/SS2	25
RD7/PSP7/SS2	17
RE0/AD8/RD/P2D	26
RE0/RD/P2D	18
RE1/AD9/WR/P2C	26
RE1/WR/P2C	18
RE2/AD10/CS/P2B	26
RE2/CS/P2D	18
RE3/AD11/P3C	26
RE3/P3C	18
RE4/AD12/P3B	26
RE4/P3B	18
RE5/AD13/P1C	26
RE5/P1C	18
RE6/AD14/P1B	26
RE6/P1B	18
RE7/AD15/ECCP2/P2A	26
RE7/ECCP2/P2A	18
RF0/AN5	19, 27
RF1/AN6/C2OUT	19, 27
RF2/AN7/C1OUT	19, 27
RF3/AN8	19, 27
RF4/AN9	19, 27
RF5/AN10/CVREF	19, 27
RF6/AN11	19, 27
RF7/SS1	19, 27
RG0/ECCP3/P3A	20, 28
RG1/TX2/CK2	20, 28
RG2/RX2/DT2	20, 28
RG3/CCP4/P3D	20, 28
RG4/CCP5/P1D	20, 28
RG5	20, 28
RG5/MCLR/VPP	13, 21
RH0/A16	29
RH1/A17	29
RH2/A18	29
RH3/A19	29
RH4/AN12/P3C	29
RH5/AN13/P3B	29
RH6/AN14/P1C	29
RH7/AN15/P1B	29
RJ0/ALE	30
RJ1/OE	30
RJ2/WRL	30
RJ3/WRH	30
RJ4/BA0	30
RJ5/CE	30
RJ6/LB	30
RJ7/UB	30
VDD	20
VDD	30
VSS	20
VSS	30

Pinout I/O Descriptions	
PIC18F6628/6723	13
PIC18F8628/8723	21
Power-Managed Modes	3
and A/D Operation	38
Product Identification System	59

R

Reader Response	58
Registers	
ADCON0 (A/D Control 0)	31
ADCON1 (A/D Control 1)	32
ADCON2 (A/D Control 2)	33
DEVID1 (Device ID 1)	42
DEVID2 (Device ID 2)	42
Revision History	51

S

Special Features of the CPU	41
Device ID Registers	41
Special Microcontroller Features	3

T

Timing Diagrams	
A/D Conversion	47
Timing Diagrams and Specifications	
A/D Conversion Requirements	47

V

Voltage-Frequency Graphs	
Extended (PIC18F8723)	44
Industrial (PIC18F8723)	44
Industrial (PIC18LF8723)	45

W

WWW Address	57
WWW, On-Line Support	7

[查询PIC18F8723供应商](#)

THE MICROCHIP WEB SITE

Microchip provides online support via our WWW site at www.microchip.com. This web site is used as a means to make files and information easily available to customers. Accessible by using your favorite Internet browser, the web site contains the following information:

- **Product Support** – Data sheets and errata, application notes and sample programs, design resources, user's guides and hardware support documents, latest software releases and archived software
- **General Technical Support** – Frequently Asked Questions (FAQ), technical support requests, online discussion groups, Microchip consultant program member listing
- **Business of Microchip** – Product selector and ordering guides, latest Microchip press releases, listing of seminars and events, listings of Microchip sales offices, distributors and factory representatives

CUSTOMER CHANGE NOTIFICATION SERVICE

Microchip's customer notification service helps keep customers current on Microchip products. Subscribers will receive e-mail notification whenever there are changes, updates, revisions or errata related to a specified product family or development tool of interest.

To register, access the Microchip web site at www.microchip.com, click on Customer Change Notification and follow the registration instructions.

CUSTOMER SUPPORT

Users of Microchip products can receive assistance through several channels:

- Distributor or Representative
- Local Sales Office
- Field Application Engineer (FAE)
- Technical Support
- Development Systems Information Line

Customers should contact their distributor, representative or field application engineer (FAE) for support. Local sales offices are also available to help customers. A listing of sales offices and locations is included in the back of this document.

Technical support is available through the web site at: <http://support.microchip.com>

PIC18F8723 FAMILY

[查询PIC18F8723供应商](#)
READER RESPONSE

It is our intention to provide you with the best documentation possible to ensure successful use of your Microchip product. If you wish to provide your comments on organization, clarity, subject matter, and ways in which our documentation can better serve you, please FAX your comments to the Technical Publications Manager at (480) 792-4150.

Please list the following information, and use this outline to provide us with your comments about this document.

To: Technical Publications Manager
RE: Reader Response
Total Pages Sent _____

From: Name _____
Company _____
Address _____
City / State / ZIP / Country _____
Telephone: (_____) _____ - _____ FAX: (_____) _____ - _____

Application (optional):

Would you like a reply? ___Y ___N

Device: PIC18F8723 Family Literature Number: DS39894B

Questions:

1. What are the best features of this document?

2. How does this document meet your hardware and software development needs?

3. Do you find the organization of this document easy to follow? If not, why?

4. What additions to the document do you think would enhance the structure and subject?

5. What deletions from the document could be made without affecting the overall usefulness?

6. Is there any incorrect or misleading information (what and where)?

7. How would you improve this document?

PIC18F8723 FAMILY

[查询PIC18F8723供应商](#)

PIC18F8723 FAMILY PRODUCT IDENTIFICATION SYSTEM

To order or obtain information, e.g., on pricing or delivery, refer to the factory or the listed sales office.

<u>PART NO.</u>		<u>X</u>	<u>/XX</u>	<u>XXX</u>
Device	Temperature Range	Package	Pattern	
Device ^{(1) (2)}	PIC18F6628/6723, PIC18F8628/8723, VDD range 4.2V to 5.5V PIC18LF6628/6723, PIC18LF8628/8723, VDD range 2.0V to 5.5V			
Temperature Range	I = -40°C to +85°C (Industrial) E = -40°C to +125°C (Extended)			
Package	PT = TQFP (Thin Quad Flatpack)			
Pattern	QTP, SQTP, Code or Special Requirements (blank otherwise)			
				Examples: a) PIC18LF6723-I/PT 301 = Industrial temp., TQFP package, Extended VDD limits, QTP pattern #301. b) PIC18F6723-E/PT = Extended temp., TQFP package, standard VDD limits.
				Note 1: F = Standard Voltage Range LF = Wide Voltage Range 2: T = in tape and reel TQFP packages only.

WORLDWIDE SALES AND SERVICE

AMERICAS

Corporate Office
2355 West Chandler Blvd.
Chandler, AZ 85224-6199
Tel: 480-792-7200
Fax: 480-792-7277
Technical Support:
<http://support.microchip.com>
Web Address:
www.microchip.com

Atlanta
Duluth, GA
Tel: 678-957-9614
Fax: 678-957-1455

Boston
Westborough, MA
Tel: 774-760-0087
Fax: 774-760-0088

Chicago
Itasca, IL
Tel: 630-285-0071
Fax: 630-285-0075

Cleveland
Independence, OH
Tel: 216-447-0464
Fax: 216-447-0643

Dallas
Addison, TX
Tel: 972-818-7423
Fax: 972-818-2924

Detroit
Farmington Hills, MI
Tel: 248-538-2250
Fax: 248-538-2260

Kokomo
Kokomo, IN
Tel: 765-864-8360
Fax: 765-864-8387

Los Angeles
Mission Viejo, CA
Tel: 949-462-9523
Fax: 949-462-9608

Santa Clara
Santa Clara, CA
Tel: 408-961-6444
Fax: 408-961-6445

Toronto
Mississauga, Ontario,
Canada
Tel: 905-673-0699
Fax: 905-673-6509

ASIA/PACIFIC

Asia Pacific Office
Suites 3707-14, 37th Floor
Tower 6, The Gateway
Harbour City, Kowloon
Hong Kong
Tel: 852-2401-1200
Fax: 852-2401-3431

Australia - Sydney
Tel: 61-2-9868-6733
Fax: 61-2-9868-6755

China - Beijing
Tel: 86-10-8528-2100
Fax: 86-10-8528-2104

China - Chengdu
Tel: 86-28-8665-5511
Fax: 86-28-8665-7889

China - Hong Kong SAR
Tel: 852-2401-1200
Fax: 852-2401-3431

China - Nanjing
Tel: 86-25-8473-2460
Fax: 86-25-8473-2470

China - Qingdao
Tel: 86-532-8502-7355
Fax: 86-532-8502-7205

China - Shanghai
Tel: 86-21-5407-5533
Fax: 86-21-5407-5066

China - Shenyang
Tel: 86-24-2334-2829
Fax: 86-24-2334-2393

China - Shenzhen
Tel: 86-755-8203-2660
Fax: 86-755-8203-1760

China - Wuhan
Tel: 86-27-5980-5300
Fax: 86-27-5980-5118

China - Xiamen
Tel: 86-592-2388138
Fax: 86-592-2388130

China - Xian
Tel: 86-29-8833-7252
Fax: 86-29-8833-7256

China - Zhuhai
Tel: 86-756-3210040
Fax: 86-756-3210049

ASIA/PACIFIC

India - Bangalore
Tel: 91-80-3090-4444
Fax: 91-80-3090-4080

India - New Delhi
Tel: 91-11-4160-8631
Fax: 91-11-4160-8632

India - Pune
Tel: 91-20-2566-1512
Fax: 91-20-2566-1513

Japan - Yokohama
Tel: 81-45-471- 6166
Fax: 81-45-471-6122

Korea - Daegu
Tel: 82-53-744-4301
Fax: 82-53-744-4302

Korea - Seoul
Tel: 82-2-554-7200
Fax: 82-2-558-5932 or
82-2-558-5934

Malaysia - Kuala Lumpur
Tel: 60-3-6201-9857
Fax: 60-3-6201-9859

Malaysia - Penang
Tel: 60-4-227-8870
Fax: 60-4-227-4068

Philippines - Manila
Tel: 63-2-634-9065
Fax: 63-2-634-9069

Singapore
Tel: 65-6334-8870
Fax: 65-6334-8850

Taiwan - Hsin Chu
Tel: 886-3-6578-300
Fax: 886-3-6578-370

Taiwan - Kaohsiung
Tel: 886-7-536-4818
Fax: 886-7-536-4803

Taiwan - Taipei
Tel: 886-2-2500-6610
Fax: 886-2-2508-0102

Thailand - Bangkok
Tel: 66-2-694-1351
Fax: 66-2-694-1350

EUROPE

Austria - Wels
Tel: 43-7242-2244-39
Fax: 43-7242-2244-393

Denmark - Copenhagen
Tel: 45-4450-2828
Fax: 45-4485-2829

France - Paris
Tel: 33-1-69-53-63-20
Fax: 33-1-69-30-90-79

Germany - Munich
Tel: 49-89-627-144-0
Fax: 49-89-627-144-44

Italy - Milan
Tel: 39-0331-742611
Fax: 39-0331-466781

Netherlands - Drunen
Tel: 31-416-690399
Fax: 31-416-690340

Spain - Madrid
Tel: 34-91-708-08-90
Fax: 34-91-708-08-91

UK - Wokingham
Tel: 44-118-921-5869
Fax: 44-118-921-5820